



1507890

User's Manual

Edition 1.0

2010/01/15



Copyright

Copyright 2010 all rights reserved. This document is copyrighted and all rights are reserved. The information in this document is subject to change without prior notice to make improvements to the products.

This document contains proprietary information and protected by copyright. No part of this document may be reproduced, copied, or translated in any form or any means without prior written permission of the manufacturer.

All trademarks and/or registered trademarks contains in this document are property of their respective owners.

Disclaimer

The company shall not be liable for any incidental or consequential damages resulting from the performance or use of this product.

The company does not issue a warranty of any kind, express or implied, including without limitation implied warranties of merchantability or fitness for a particular purpose.

The company has the right to revise the manual or include changes in the specifications of the product described within it at any time without notice and without obligation to notify any person of such revision or changes.

Trademark

All trademarks are the property of their respective holders.

Packing List:

Hardware:

1507890 SATAII PCI Express mini card x1

Cable kit:



DF14 10PIN for SATA x 2

CD Content:

Driver & User's Manual

1.0 <Product Specification>

General Specification	
Form Factor	PCI Express mini card
Controller	Silicon Image 3132
Features	2 x SATAII provides up to 300MB/s of transferring rate (Supply RAID Function)
Accessories	1 x DF14 10-pin SATA Cable
Dimensions (W x D)	30.00mm x 50.95mm

1.1 <Component Placement>

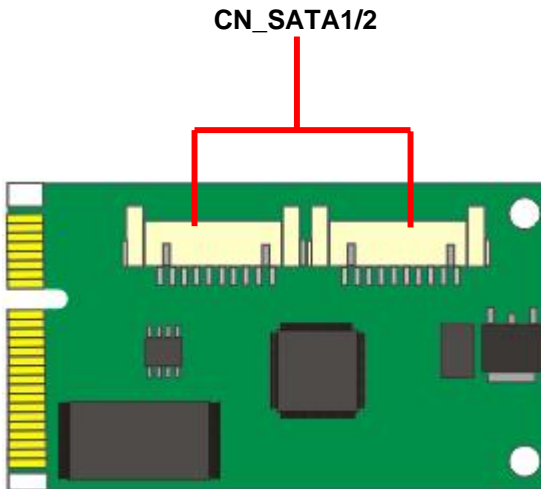

1.2 <Mechanical Drawing>

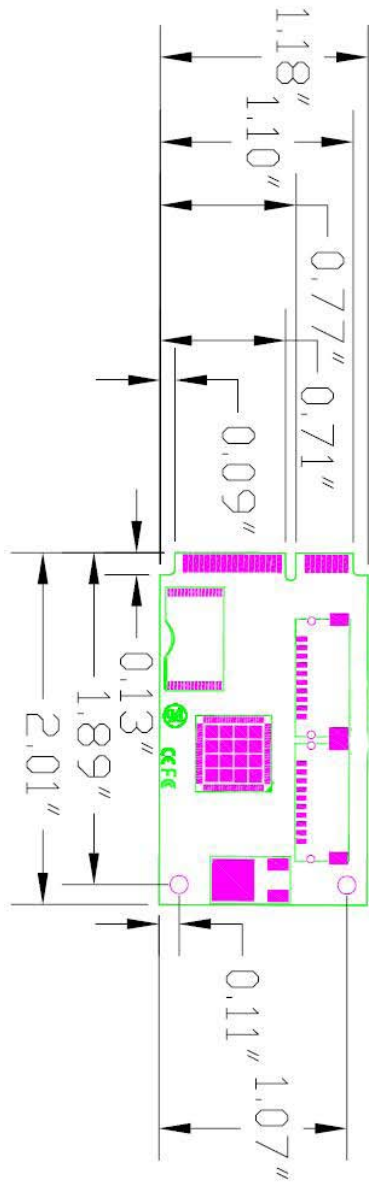

1.3 <Connector Reference>

Connector: CN_SATA1/2

Type: DF14 10-pin pitch=1.25mm

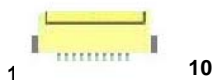

Pin	Description	Pin	Description
1	GND	2	TXP0/1
3	TXN0/1	4	GND
5	SATA_LED0/1	6	SATA_LED0#/1#
7	GND	8	RXN0/1
9	RXP0/1	10	GND

1.4 <SATA RAID Configuration>

The board integrates Silicon Image 3132 with RAID function for Serial ATA II drives, and supports the configurations below:

RAID 0 (Striping): Two hard drives operating as one drive for optimized data R/W performance. It needs two unused drives to build this operation.

RAID 1 (Mirroring): Copies the data from first drive to second drive for data security, and if one drive fails, the system would access the applications to the workable drive. It needs two unused drives or one used and one unused drive to build this operation. The second drive must be the same or larger size than first one.

For more information of Silicon Image Technology, please visit silicon Image website.

If you need to install an operation system on the RAID set, please use the driver disk attached in the package when it informs you to obtain the RAID drivers.

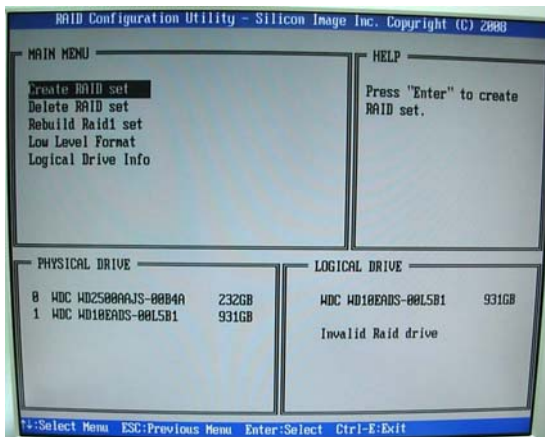

Please press <CTRL+S> to enter the RAID configuration menu.

You can setup the RAID under operation system for Microsoft® Windows XP SP2(or later) or Windows 2000 SP4(or later) version.

Any advice or comments about our products and service, or anything we can help you with please don't hesitate to contact with us. We will do our best to support you for your products, projects and business.

Global American Inc.

Address: 17 Hampshire Drive
Hudson, NH 03051

TEL: Toll Free (U.S. Only) 800-833-8999
(603)886-3900

FAX: (603)886-4545

Website: <http://www.globalamericaninc.com>

E-Mail: salesinfo@globalamericaninc.com

