



2801210

User's Manual

Version 1.0



6.7" x 6.7" (170 mm x 170 mm) Mini-ITX Embedded 1.0 GHz VIA C3 CPU Motherboard w/VGA / optional LVDS Interface w/Mini-AGP or DVI Interface , DUAL 10/100 LAN (VIA VT6103 + Realtek 8100B), AC97 Audio, CF Type II Skt, VIA CN400 & VT8237 Chipset, (1) 184-Pin DDR266/333/400 Skt (1GB Max), SATA Interface, IEEE 1394,1-PCI Exp Slot, Mini-AGPWDT, Multi I/O Ports, etc



UniChrome Pro

Copyright

Copyright 2004 - 2005. All rights reserved. This document is copyrighted and all rights are reserved. The information in this document is subject to change without prior notice to make improvements to the products.

This document contains proprietary information and protected by copyright. No part of this document may be reproduced, copied, or translated in any form or any means without prior written permission of the manufacturer.

All trademarks and/or registered trademarks contains in this document are property of their respective owners.

Disclaimer

The company shall not be liable for any incidental or consequential damages resulting from the performance or use of this product.

The company does not issue a warranty of any kind, express or implied, including without limitation implied warranties of merchantability or fitness for a particular purpose.

The company has the right to revise the manual or include changes in the specifications of the product described within it at any time without notice and without obligation to notify any person of such revision or changes.

Trademark

All trademarks are the property of their respective holders.

Packing List

Please check the package before you starting setup the system

Hardware:

2801210 series motherboard x 1

Cable Kit:

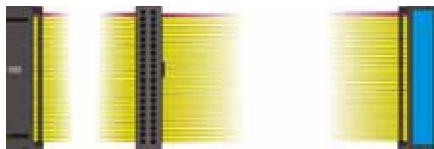

40-pin ATA100 IDE flat cable x 1



26-pin slim type floppy cable x 1



Serial ATA ribbon cable x 1

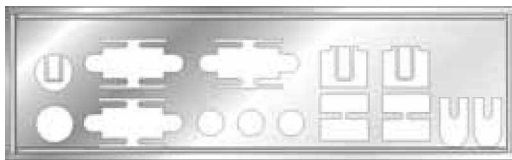

I/O Shield x 1

Other Accessories:

Divers CD (including User's Manual) x 1

Index

Chapter 1 <Introduction>	7
1.1 <Product Overview>	7
1.2 <Product Specification>	8
1.3 <Mechanical Drawing>	10
1.4 <Block Diagram>	11
Chapter 2 <Hardware Setup>	12
2.1 <Connector Location>	12
2.2 <Jumper Reference>	13
2.3 <Connector Reference>.....	14
2.3.1 <Internal Connector>.....	14
2.3.2 <External Connector>.....	14
2.4 <CPU and Memory Setup>	15
2.4.1 < CPU>	15
2.4.2 <Memory>.....	15
2.5 <CMOS Setup>	16
2.6 <Enhanced IDE & CF Interface>.....	17
2.7 <Serial ATA Interface>	18
2.8 <Floppy Port>.....	19
2.9 <LAN Interface>	20
2.10 <Onboard Display Interface>	21
2.11 <Onboard Audio Interface>.....	22
2.12 <USB2.0 & IEEE1394 Interface>	24
2.13 <GPIO Interface>	26
2.14 <Serial Port>	27
2.15 <Power and Fan Connector>	28
2.15.1 <Power Input>.....	28
2.15.2 <Fan Connector>	28

2.16 <Indicator and Switch>	29
Chapter 3 <System Configuration>.....	31
3.1 <SATA RAID Configuration>.....	31
3.2 <Audio Configuration>	33
Chapter 4 <BIOS Setup>.....	34
Appendix A <I/O Port Pin Assignment>.....	35
A.1 <IDE Port>	35
A.2 <Floppy Port>	37
A.3 <IrDA Port>	37
A.4 <VGA Port >.....	38
A.5 <Serial ATA Port>	38
A.6 <Serial Port>	38
A.8 <LAN Port>	39
A.9 <PS/2 Keyboard & Mouse Port>.....	39
Appendix B <Flash BIOS>.....	41
B.1 BIOS Auto Flash Tool	41
B.2 Flash Method.....	41
Appendix C <System Resources>	43
C.1 <I/O Port Address Map>.....	43
C.2 <Memory Address Map>	45
C.3 <System IRQ & DMA Resource>	46
C.3.1 <IRQ>.....	46
C.3.2 <DMA>	47
Appendix D <Power Consumption Test>.....	49
Contact Information.....	50

(The Page is Left For Blank)

Chapter 1 <Introduction>

1.1 <Product Overview>

2801210 is the Mini-ITX motherboard based on VIA chipset. It integrates the last VIA embedded chipset for CN400 with VT8237, DDR266/333/400 SDRAM, and serial ATA with RAID to provide the economical embedded platform.

VIA CN400 & VT8237 Chipset

The board comes with the VIA last embedded chipset of CN400, supports DDR266/333/400 SDRAM, integrated the S3 Graphics UniChrome Pro IGP graphics core, hardware MPEG-2 and MPEG-4 acceleration.

The VT8237 provides the board to support Ultra V-Link (1GB/s) with CN400, two serial ATA ports with RAID array function, 6 x USB2.0 ports and 5.1 channel AC97 audio.

Multimedia solution

The board provides optional mini-AGP interface to work with AGP 8x graphic card.

Onboard AC97 codec provides the high quality of sound including 20-bit, stereo ADC and 6-channel stereo DACs.

Dual LAN Interface

2801210 also comes with dual 10/100Mbps LAN interface, support boot-on-LAN and wake-on-LAN function.

High Speed Hot-plug Interface

Based on VIA VT8237, the board provides 6 USB2.0 interfaces with up to 480Mbps of transferring rate, 3 IEEE1394a interfaces with up to 400Mbps of transferring rate.

Expanded UCR for remote Operating SETUP Bios Feature

Expanded Universal Console Redirection (UCR) is a feature for monitoring POST messages and running Setup and an operation system from a remote serial terminal.

1.2 <Product Specification>

General Specification

Form Factor	Mini-ITX motherboard
CPU	Embedded VIA C3/Eden processor Ratio: 1.0GHz (default) L2 Cache: 128KB Front side bus: 133MHz
Memory	1 x 184-pin DDR 266/333/400 SDRAM up to 1GB Unbuffered, none-ECC memory supported only
Chipset	VIA CN400 and VT8237
BIOS	Phoenix-Award v6.00PG 4Mb PnP flash BIOS
Green Function	Power saving mode includes doze, standby and suspend modes. ACPI version 1.0 and APM version 1.2 compliant
Watchdog Timer	System reset programmable watchdog timer with 1 ~ 255 sec./min. of timeout value
Real Time Clock	VIA VT8237 built-in RTC with lithium battery
Enhanced IDE	Enhanced IDE interface supports dual channels and up to 4 ATAPI devices at Ultra DMA133 One 40-pin and one 44-pin IDE port onboard
Serial ATA	VIA VT8237 integrates 2 Serial ATA interface RAID 0, 1 array Technology supported

Multi-I/O Port

Chipset	VIA VT8237 with Winbond W83697UF controller
Serial Port	Two external & two internal RS-232 serial ports
USB Port	Six Hi-Speed USB 2.0 ports with 480Mbps of transfer rate
Parallel Port	None
Floppy Port	One slim type Floppy port
IrDA Port	One IrDA compliant Infrared interface supports SIR
K/B & Mouse	External PS/2 keyboard and mouse ports on rear I/O panel
GPIO	One 12-pin Digital I/O connector with 8-bit programmable I/O interface
Hardware Monitor	Fan speed, CPU temperature and voltage monitoring

VGA Display Interface

Chipset	VIA CN400 built-in S3 Graphics UniChrome Pro IGP graphics core
Core Frequency	200MHz
Memory	BIOS selectable 16/32/64MB shard with system memory
Display Type	CRT, LCD monitor with analog display
Connector	External DB15 female connector on rear I/O panel

Ethernet Interface

Chipset	VIA VT6103 PHY & REALTEK 8100B
Type	10Base-T / 100Base-TX auto-switching Fast Ethernet Full duplex, IEEE802.3U compliant
Connector	Dual External RJ45 connectors with LED on rear I/O panel

Audio Interface

Chipset	VIA VT1616
Interface	5.1 channel 3D audio with Line-in, Line-out and MIC-in
Connector	External Audio phone jack for Line-out/Front, Line-in/Rear and MIC(stereo)-in/Center Onboard audio connector with pin header Onboard CD-IN connector Onboard 5-pin S/PDIF interface (optional output kit required)

Expansive Interface

Mini-AGP	1 x AGP 8x interface supported
PCI	1 x PCI slot supports up to two PCI devices through riser card
IEEE1394	VIA VT6306 controller integrated IEEE1394a supported Up to 400Mb/s of transferring rate

Power and Environment

Power Requirement	Standard ATX 20-pin power supply
Dimension	170 (L) x 170 (H) mm

Software support

Operation System	Windows 98SE/ME, Windows 2000, Windows XP Windows CE 4.0 or later, Windows XP Embedded Linux (Fedora Core 1, Mandrake 9.2 and Red Hat 9.0)
------------------	--

Ordering Code

2801210	VIA CN400 with Embedded C3 1.0GHz, VGA, SATA, 5.1CH Audio, CF, PCI, 4 x RS232, Dual LAN, Mini-AGP
----------------	---

1. The specifications may be different as the actual production.

1.3 <Mechanical Drawing>

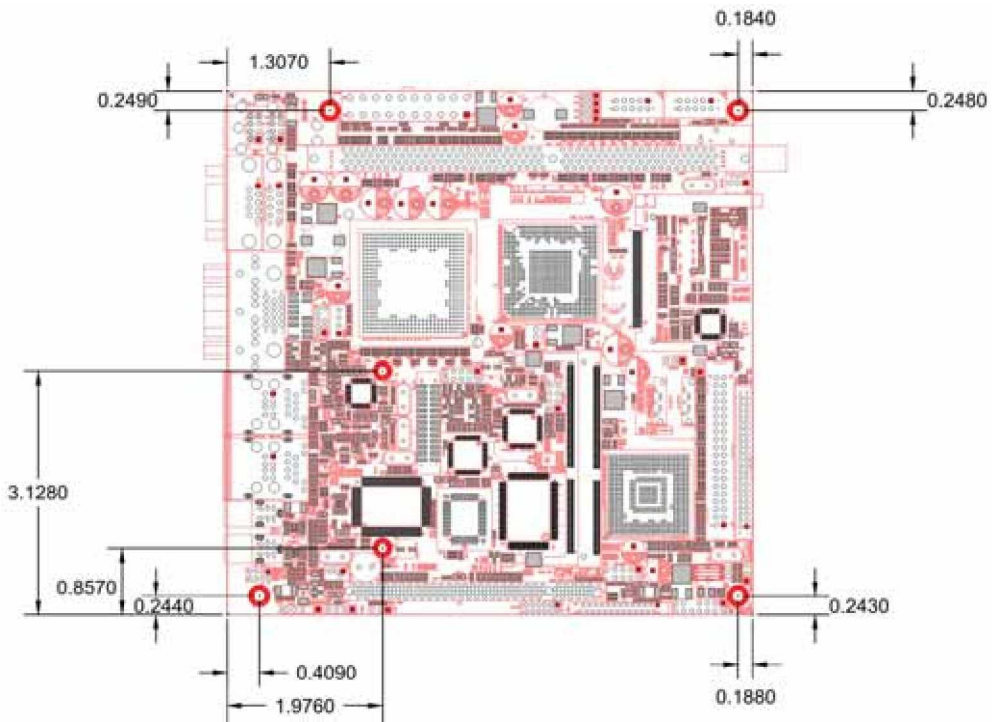

(Measured by Inches)

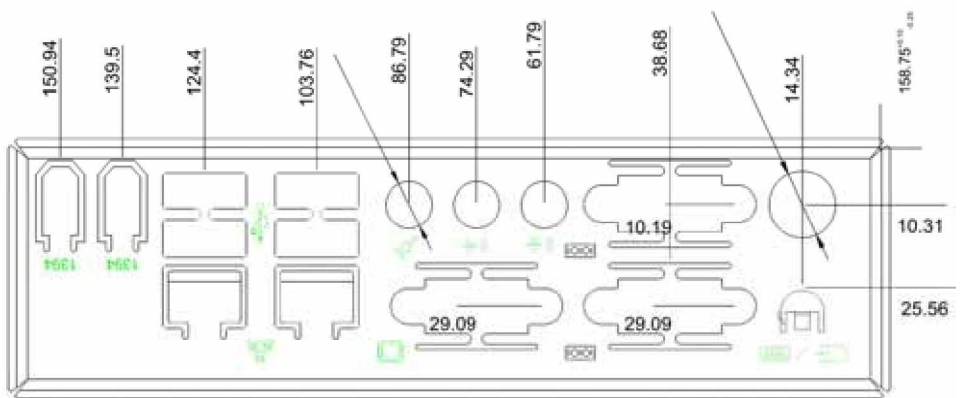

(Measured by Mini-meter)

1.4 <Block Diagram>

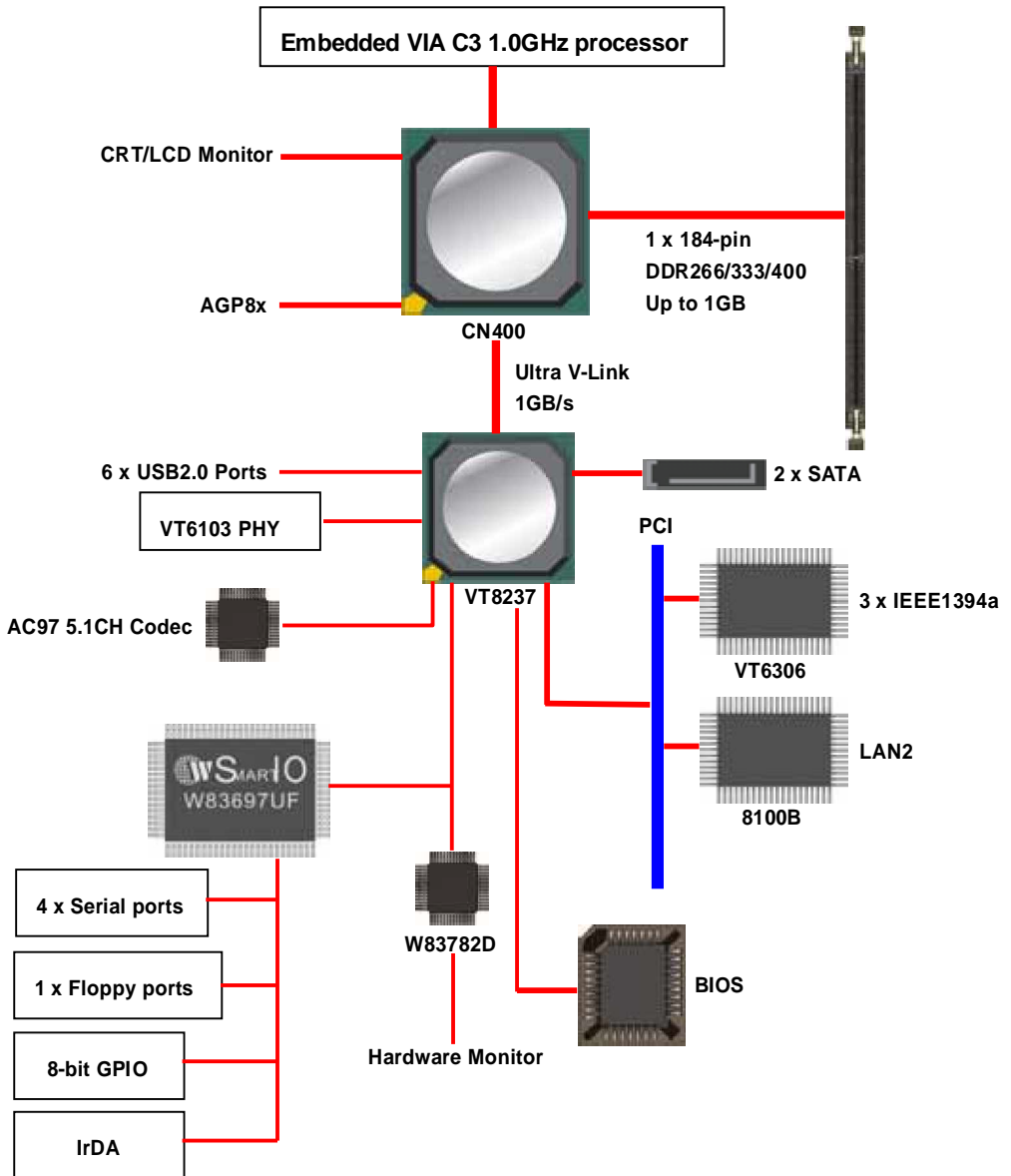

Chapter 2 <Hardware Setup>

2.1 <Connector Location>

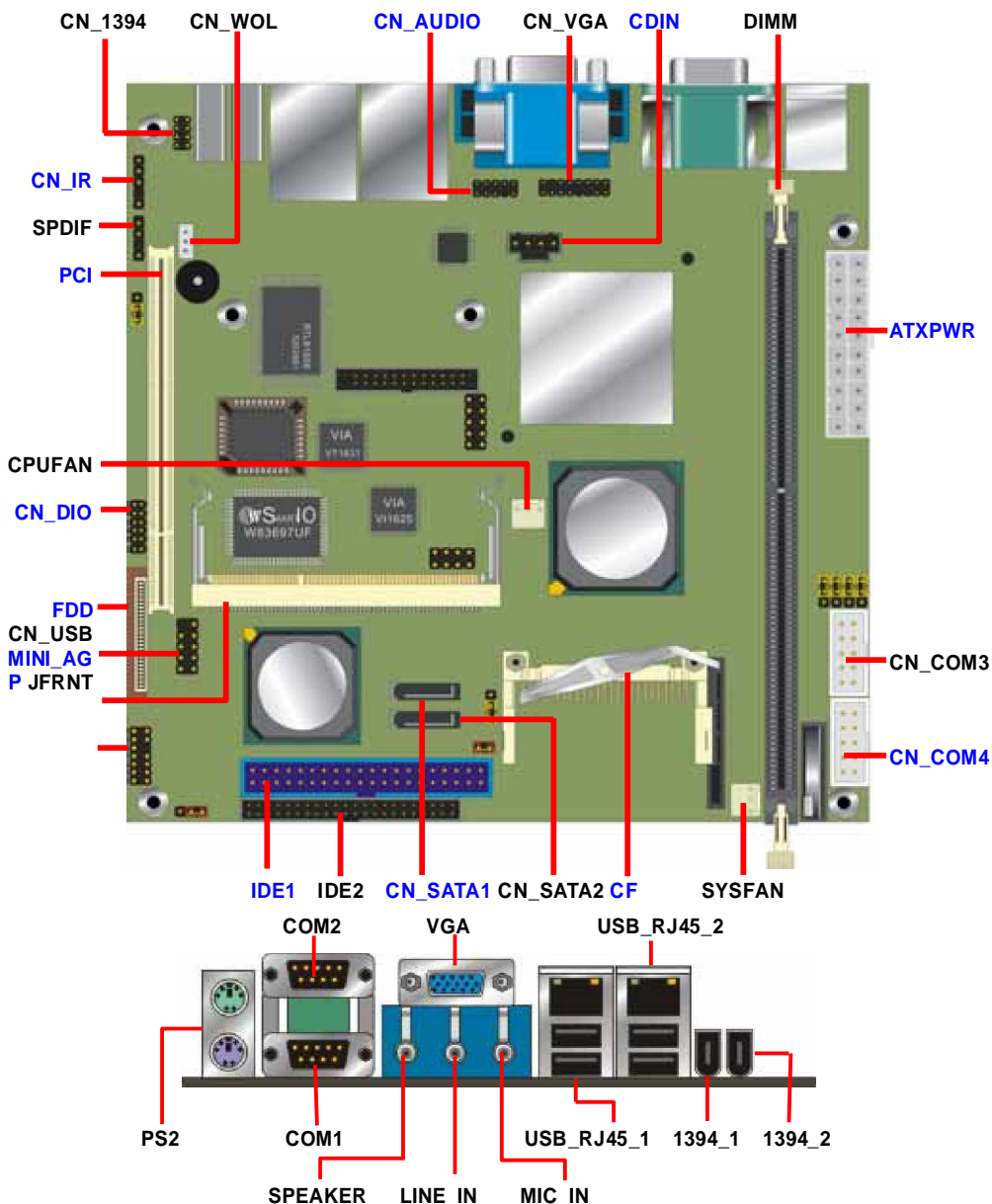

2.2 <Jumper Reference>

Jumper	Function
JRTC	CMOS Operating/Clear Setting
JDOM	IDE1 Pin-20 voltage setting
JLAN	LAN2 Enable/Disable setting
JCFSEL	Compact Flash address mode setting
JC1/JC2/JC3/JC4	Serial port output voltage setting

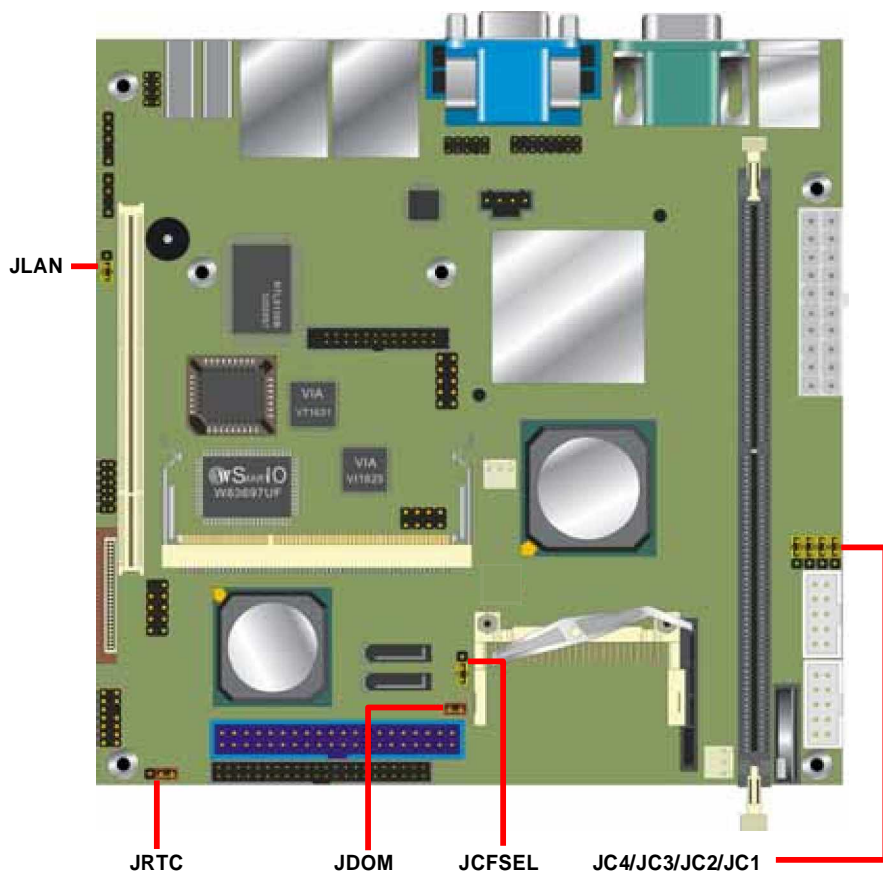

2.3 <Connector Reference>

2.3.1 <Internal Connector>

Connector	Function	Remark
DIMM	184-pin DDR SDRAM DIMM	Standard
IDE1	40-pin primary IDE connector	Standard
IDE2	44-pin secondary IDE connector	Standard
FDD	26-pin slim type floppy connector	Standard
CN_SATA1/2	7-pin Serial ATA connector	Standard
ATXPWR	20-pin power supply connector	Standard
CN_AUDIO	5 x 2-pin audio connector	Standard
CDIN	4-pin CD-ROM audio input connector	Standard
SPDIF	Digital audio optical interface	Standard
CN_DIO	6 x 2-pin digital I/O connector	Standard
CN_USB	5 x 2-pin USB connector	Standard
CN_1394	4 x 2-pin IEEE1394 connector	Standard
CPUFAN	3-pin CPU cooler fan connector	Standard
SYSFAN	3-pin system cooler fan connector	Standard
CN_COM3	5 x 2-pin RS232 serial port	Standard
CN_COM4	5 x 2-pin RS232 serial port	Standard
CN_IR	5-pin IrDA connector	Standard
CN_WOL	3-pin wake on LAN connector	Standard
CF	Compact Flash Type II socket	Standard
MINI_AGP	AGP 8x interface	Standard
JFRNT	14-pin front panel switch/indicator connector	Standard

2.3.2 <External Connector>

Connector	Function	Remark
VGA	DB15 VGA connector	Standard
USB_RJ45_1/2	Dual USB and RJ45 LAN connector	Standard
COM1/2	Serial port connector	Standard
PS2	PS/2 Keyboard/Mouse connector	Standard
SPEAKER	Audio Line-out port	Standard
LINE_IN	Audio Line-in port	Standard
MIC_IN	Audio Microphone input port	Standard
1394_1/2	IEEE1394 port	Standard

2.4 <CPU and Memory Setup>

2.4.1 < CPU >

The board supports Embedded VIA C3/Eden processor, default ratio is C3 1.0GHz with CPU cooler fan.

2.4.2 <Memory>

The board supports one 184-pin DDR266/333/400 SDRAM and up to 1GB of capacity, only non-ECC, unbuffered memory is supported.

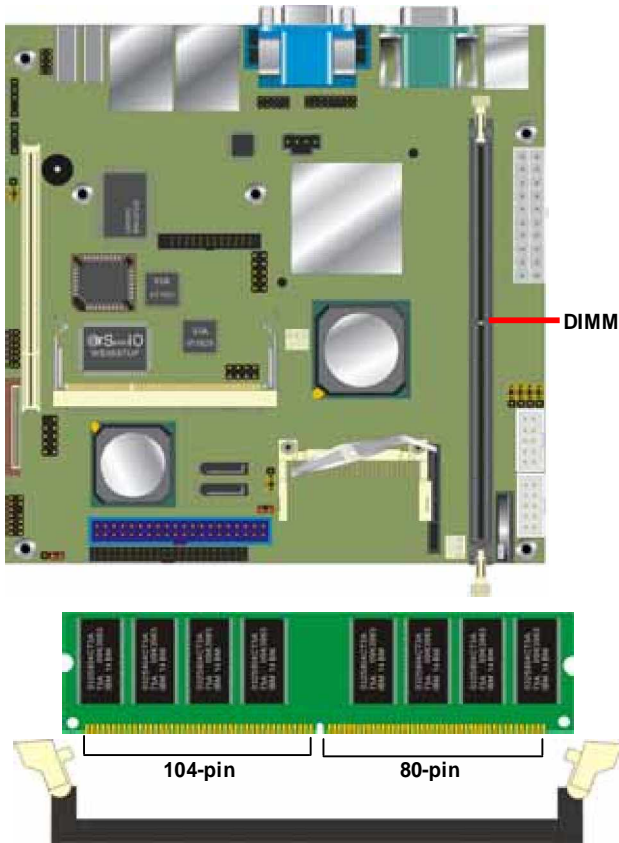

Please check the pin number to match the socket side well before installing memory module.

2.5 <CMOS Setup>

The board's data of CMOS can be setting in BIOS. If the board refuses to boot due to inappropriate CMOS settings, here is how to proceed to clear (reset) the CMOS to its default values.

Jumper: JRTC

Type: Onboard 3-pin jumper

JRTC	Mode
1-2	Clear CMOS
2-3	Normal Operation

Default setting

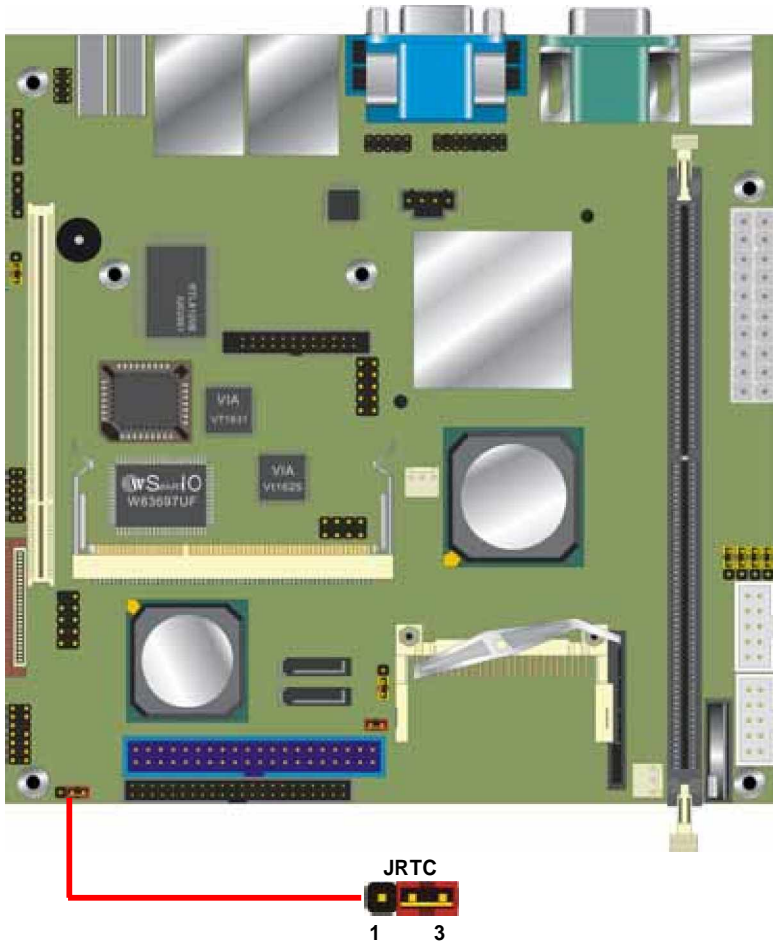

2.6 <Enhanced IDE & CF Interface>

The board supports two enhanced IDE interface, dual channel for 4 ATAPI devices with ATA133. Based on embedded application, the board has one 40-pin IDE connector with jumper selectable for pin-20 +5V supported, and one 44-pin IDE connector. The jumper **JDOM** is two-pin type for pin-20 supplied with +5V to apply the DOM (Disk on Module).

The board also provides a Compact Flash Type II socket with jumper (**JCFSEL**) selectable slave/Master mode on secondary IDE channel.

Jumper: **JDOM**

Type: onboard 3-pin header

JDOM	Mode
ON	IDE1 pin-20 5V power supply enable
OFF	No 5V power supply on IDE1 pin-20

Default setting

Jumper: **JCFSEL**

Type: onboard 3-pin header

JCFSEL	Mode
1-2	Master
2-3	Slave

Default setting

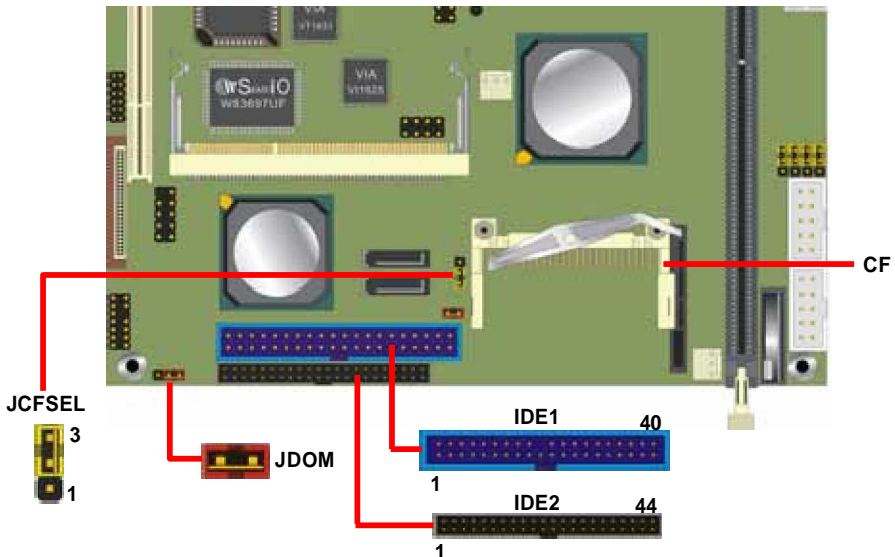

2.7 <Serial ATA Interface>

Based on VIA VT8237 Southbridge, the board supports two Serial ATA interfaces with RAID 0 and 1 array function. The following is the list of the specification of the Serial ATA.

1. Complies with Serial ATA Specification Revision 1.0
2. Dual Channel master mode PCI
3. On-chip two-channel Serial ATA (S-ATA) PHY for support of up to two S-ATA devices directly.
4. S-ATA drive transfer rate is capable of up to 150 MB/s per channel (serial speed of 1.5 Gbit/s).

For more information please visit VIA website (www.via.com.tw)

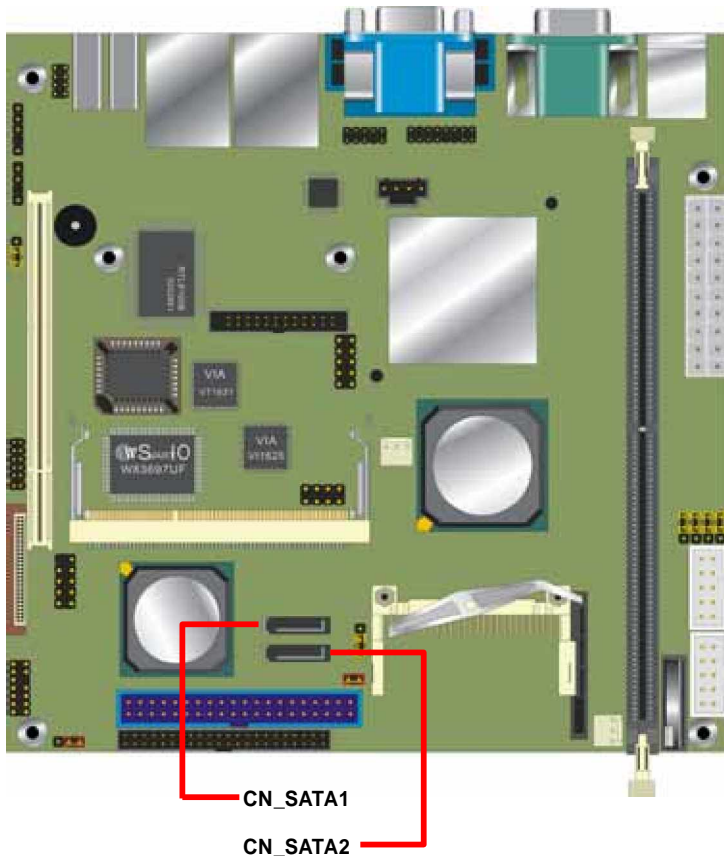

2.8 <Floppy Port>

The board provides a slim type floppy port; please use the 26-pin ribbon cable in the package to connect the floppy device.

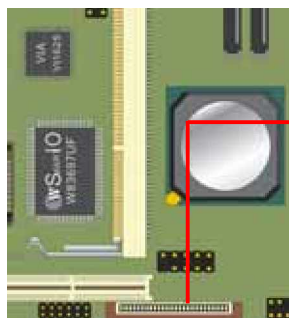
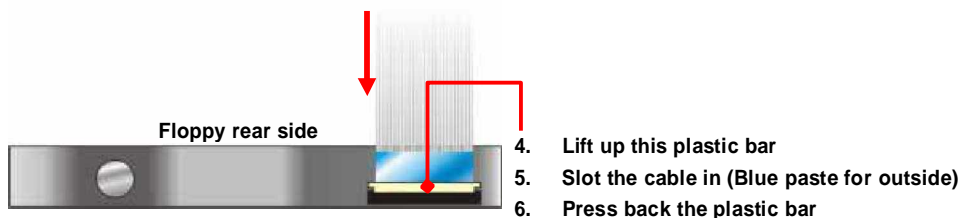
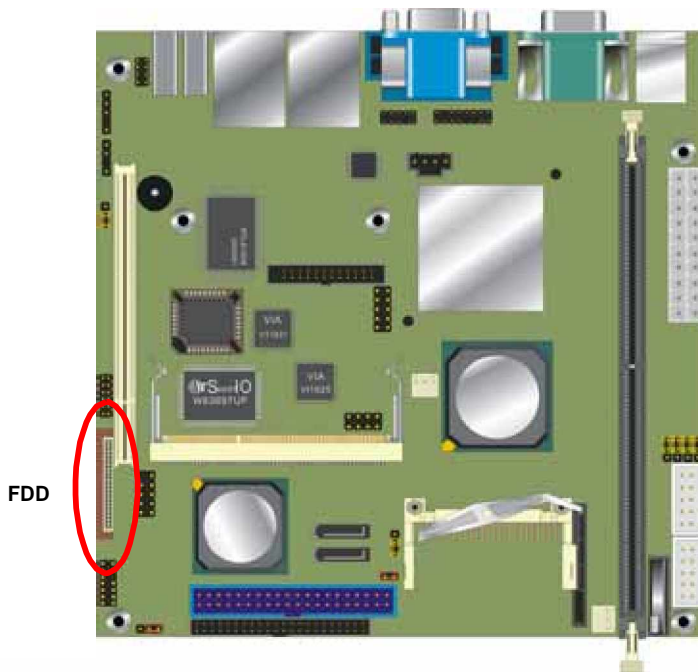

1. Lift up the brown plastic bar
2. Slot the cable in (Blue paste for brown bar side)
3. Press back the plastic bar

2.9 <LAN Interface>

The board provides two 10/100Mbps LAN interfaces with VIA VT6103 PHY and REALTEK 8100B PCI controller, and compliant with standard IEEE 802.3 Ethernet interface for 1000BASE-T and 100BASE-TX. The jumper of JLAN can let you enable/disable LAN2 with REALTEK 8100B. The **CN_WOL** is the interface for your PCI LAN card to wake the system up.

Jumper: **JLAN**

Type: Onboard 3-pin jumper

JLAN	Mode
1-2	Enable
2-3	Disable

Default setting

Connector: **CN_WOL**

Type: onboard 3-pin (1 x 3) wafer connector

Pin	1	2	3
Description	+5V Standby	Ground	WOL-Ctrl

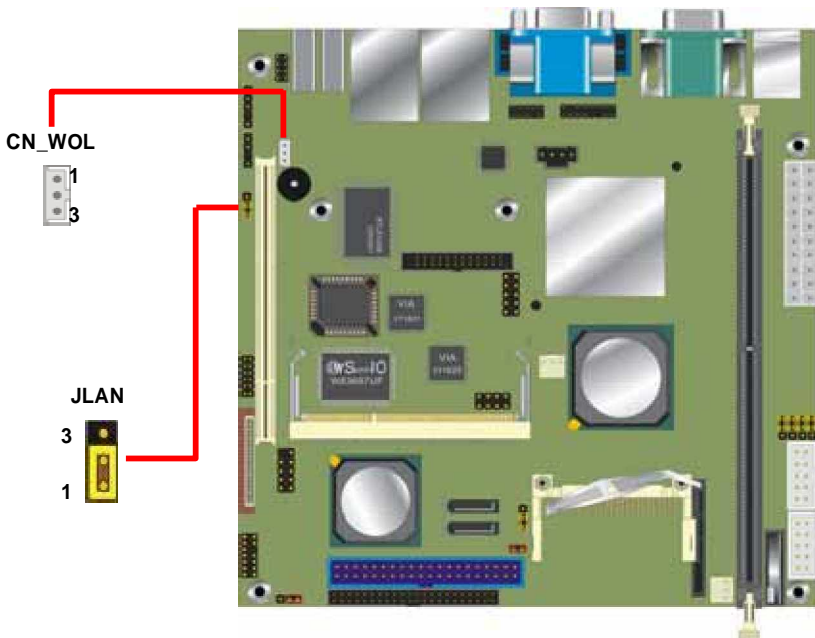

2.10 <Onboard Display Interface>

Based on VIA CN400, the board supports integrated S3 Graphics UniChrome Pro IGP graphics, with BIOS selectable 16/32/64MB shared with system memory for frame buffer.

The board provides a DB15 VGA connector on the rear I/O panel, and one **CN_VGA** connector which enable you to connect the VGA interface with Mini-AGP graphic card, thus you can have the same display output while applying a graphic card without additional output connector on chassis.

Connector: **CN_VGA**

Type: 16-pin (2 x 8) pin header (pitch = 2.0mm)

1	Red	2	Green
3	Blue	4	N/C
5	Ground	6	Ground
7	Ground	8	Ground
9	N/C	10	Ground
11	N/C	12	Data
13	HSYNC	14	VSYNC
15	Clock	16	EXCRT

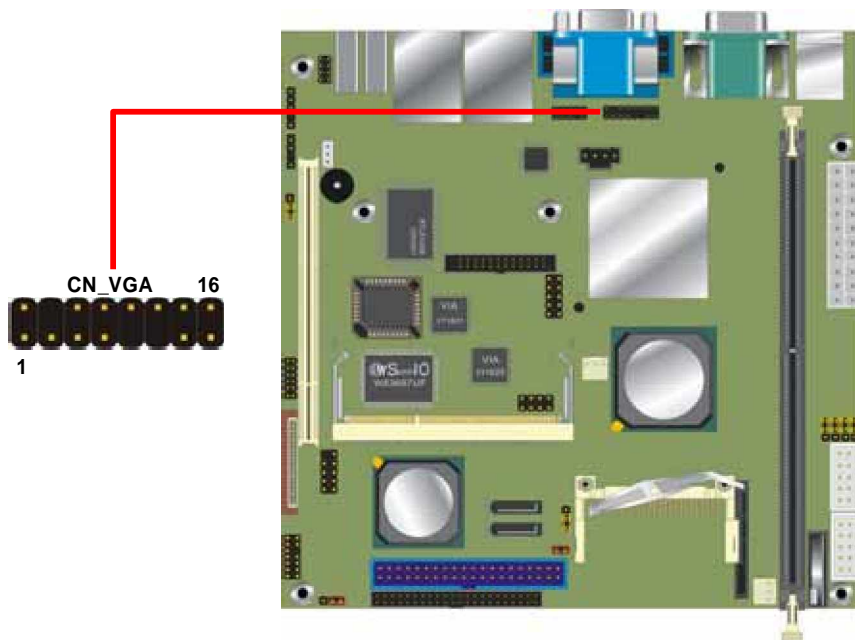

2.11 <Onboard Audio Interface>

The board provides the onboard AC97 5.1-channel audio interface with VIA VT1616, with three phone jacks on rear I/O panel for Line-out, Line-in, MIC(stereo)-in as 2-channel sound system, and Front, Rear, Center as 5.1-channel sound system. It also has one 10-pin header for additional audio output and 4-pin S/PDIF interface for optical/coaxial output.

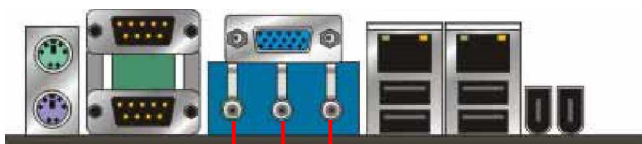
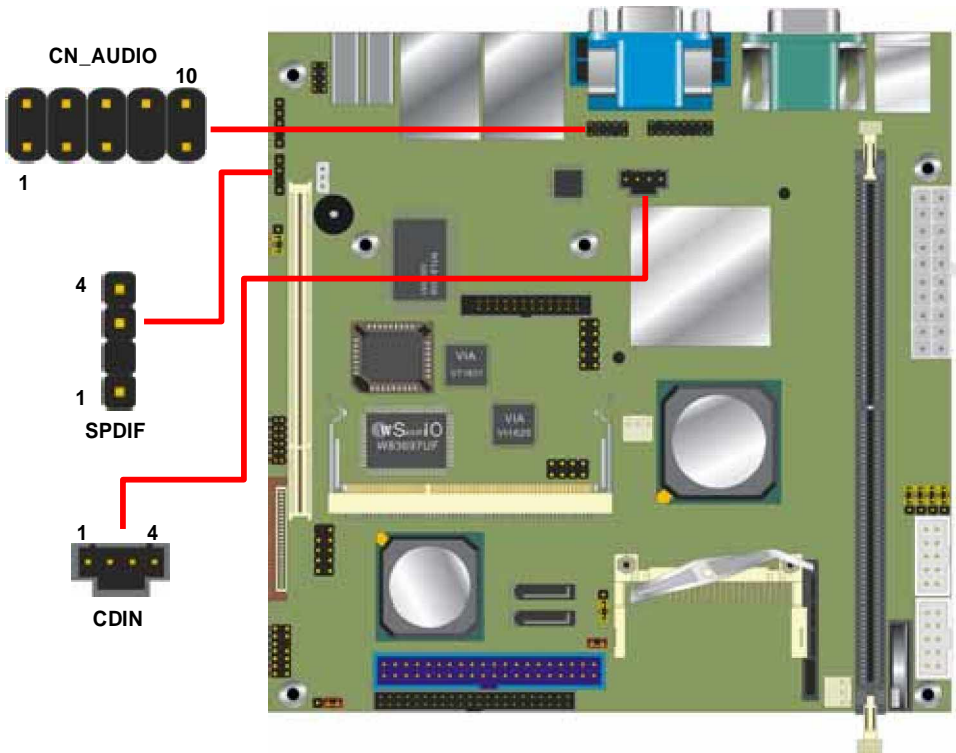

Line-out Front Line-in Rear MIC-in (system setup with 2-channel) Center (system setup with 5.1-channel)

Connector: CN_AUDIO

Type: 10-pin (2 x 5) header (pitch = 2.00mm)

Pin	Description	Pin	Description
1	Line – Left	2	Ground
3	Line – Right	4	MIC1
5	MIC2	6	Ground
7	N/C	8	Line Out – Left
9	Line Out – Right	10	Ground

Connector: CDIN

Type: 4-pin header (pitch = 2.54mm)

Pin	Description
1	CD – Left
2	Ground
3	Ground
4	CD – Right

Connector: SPDIF

Type: 4-pin header (pitch = 2.54mm)

Pin	Description
1	+5V
2	N/C
3	SPDIFOUT
4	GND

2.12 <USB2.0 & IEEE1394 Interface>

Based on VIA VT8237, the board provides 6 USB2.0 ports, and 3 IEEE1394a with VIA VT6306. The USB2.0 interface provides up to 480Mbps of transferring rate, the IEEE1394a provides up to 400Mbps of transferring rate.

Interface	IEEE1394a	USB2.0
Controller	VIA VT6306	VIA VT8237
Transfer Rate	100/200/400Mb/s	Up to 480Mb/s
Output Voltage	12V	500mA

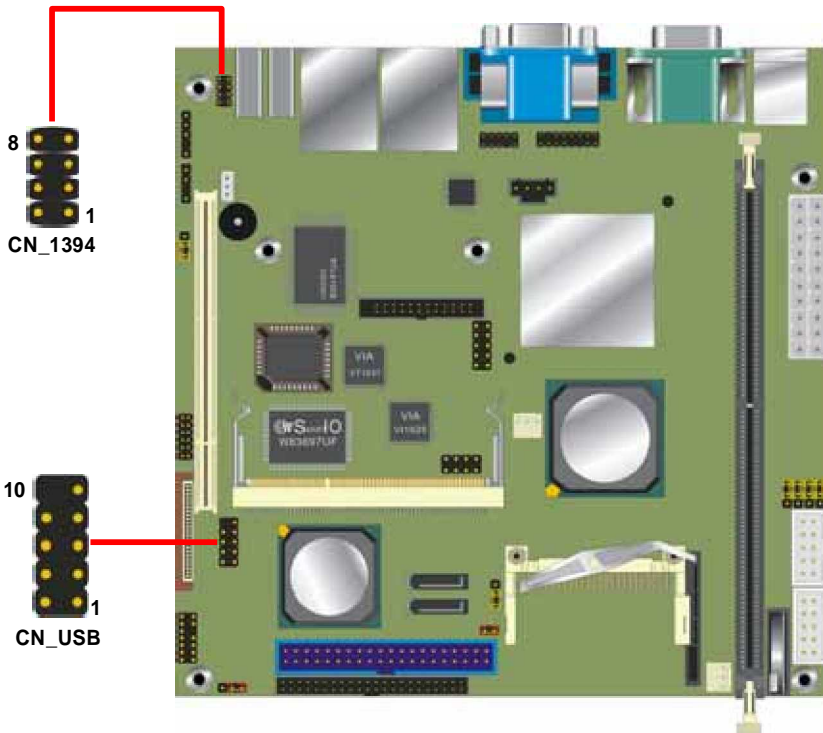
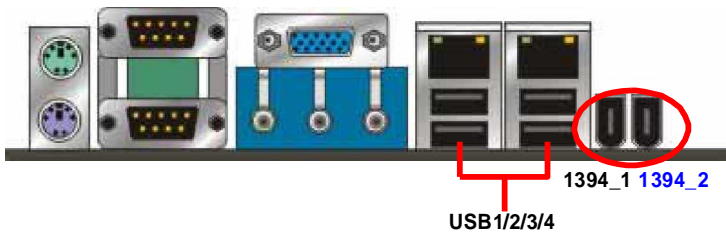

Connector: **CN_1394**

Type: 8-pin header (pitch = 2.00mm)

Pin	Description	Pin	Description
1	CPWR	2	GND
3	TPB2-	4	TPB2+
5	TPA2-	6	TPA2+
7	GND	8	GND

Connector: **CN_USB**

Type: 10-pin (5 x 2) header for USB5/6 Ports

Pin	Description	Pin	Description
1	VCC	2	VCC
3	Data0-	4	Data1-
5	Data0+	6	Data1+
7	Ground	8	Ground
9	Ground	10	N/C

PS: The USB2.0 will be only active when you connecting with the USB2.0 devices, if you insert an USB1.1 device, the port will be changed to USB1.1 protocol automatically. The transferring rate of USB2.0 as 480Mbps is depending on device capacity, exact transferring rate may not be up to 480Mbps.

2.13 <GPIO Interface>

The board provides a programmable 8-bit digital I/O interface; you can use this general purpose I/O port for system control like POS or KIOSK.

Connector: **CN_DIO**

Type: onboard 2 x 6-pin header, pitch=2.0mm

Pin	Description	Pin	Description
1	Ground	2	Ground
3	GP0	4	GP4
5	GP1	6	GP5
7	GP2	8	GP6
9	GP3	10	GP7
11	VCC	12	+12V

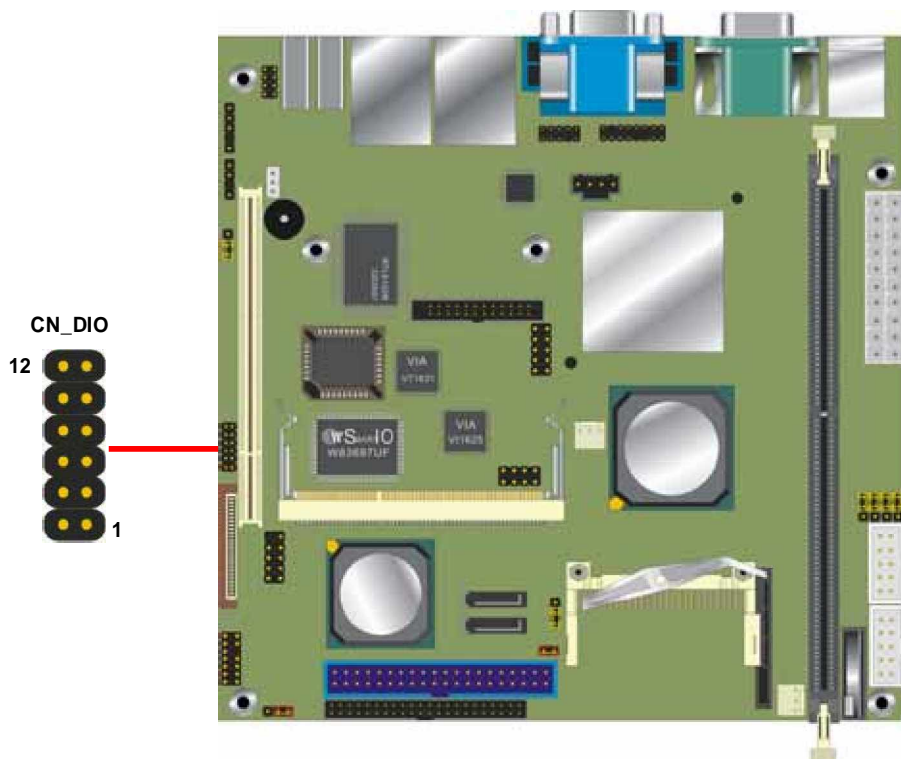

2.14 <Serial Port>

The board provides four RS232 serial ports, with jumper selectable +5V/+12V output for COM3 and COM4.

Connector: **CN_COM3/4**

Type: 10-pin (5 x 2) header for COM3/4

Pin	Description	Pin	Description
1	RIN1	2	RIN3
3	DOUT2	4	DOUT3
5	GND	6	RIN2
7	DOUT1	8	RIN4
9	-XRI	10	N/C

Jumper: **JC1/3**

Type: Onboard 3-pin jumper

JC1/3	Mode
1-2	COM3/4 pin-1 for +5V output
2-3	RIN1

Default setting

Jumper: **JC2/4**

Type: Onboard 3-pin jumper

JC2/4	Mode
1-2	COM3/4 pin-9 for +12V output
2-3	-XRI

Default setting

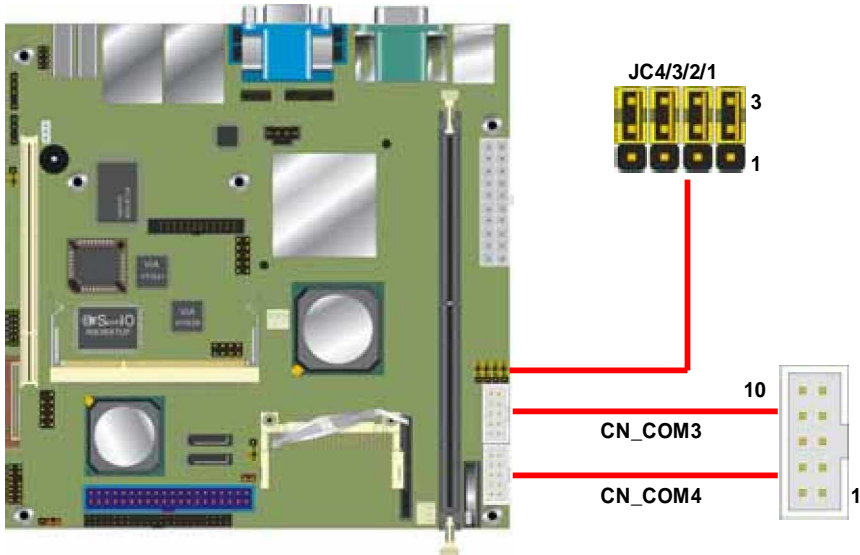

2.15 <Power and Fan Connector>

2.15.1 <Power Input>

Connector: **ATXPWR**

Type: 20-pin ATX power connector

PIN assignment			
1	12V	11	5V
2	5VSB	12	5V
3	PWOK	13	-5V
4	GND	14	GND
5	5V	15	GND
6	GND	16	GND
7	5V	17	PSON
8	GND	18	GND
9	3.3V	19	-12
10	3.3V	20	3.3V

2.15.2 <Fan Connector>

Connector: **CPUFAN, SYSFAN**

Type: 3-pin fan wafer connector

Pin	Description	Pin	Description	Pin	Description
1	Ground	2	+12V	3	Fan Control

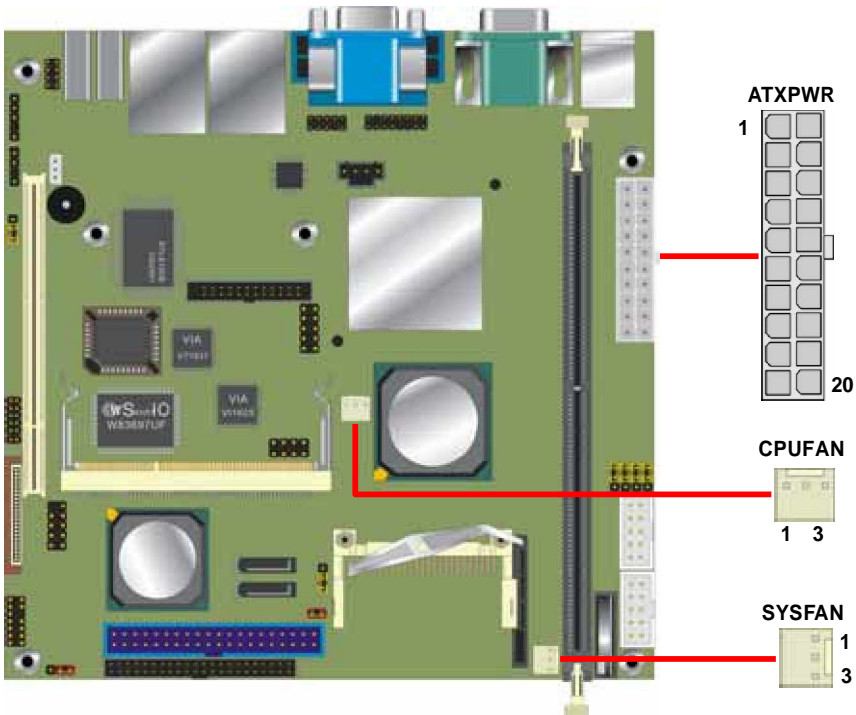

2.16 <Indicator and Switch>

The **JFRNT** provides front control panel of the board, such as power button, reset and beeper, etc. Please check well before you connecting the cables on the chassis.

Connector: **JFRNT**

Type: onboard 14-pin (2 x 7) 2.54-pitch header

Function	Signal	PIN		Signal	Function
IDE LED	VCC	1	2	VCC	Power LED
	Active	3	4	N/C	
Reset	Reset	5	6	GND	Speaker
	GND	7	8	VCC	
N/C		9	10	N/C	
Power Button	PWRBT	11	12	N/C	
	5VSB	13	14	SPKIN	

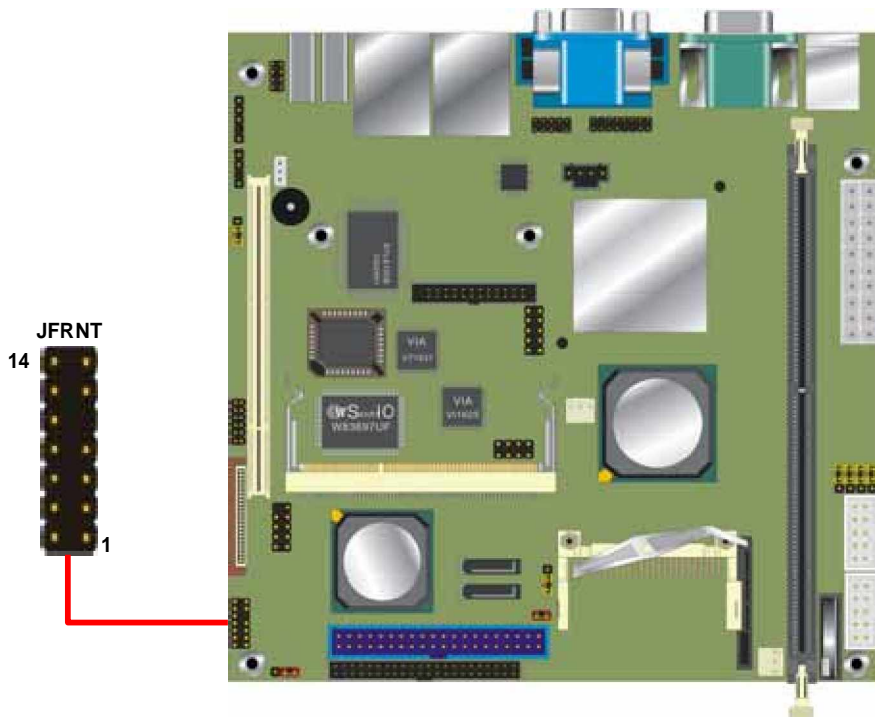

(This Page is Left For Blank)

Chapter 3 <System Configuration>

3.1 <SATA RAID Configuration>

The board supports two Serial ATA ports onboard, and supports RAID 0, 1 and JBOD disk array, the RAID 0, 1 and JBOD are specified below:

RAID 0 (Striping): Two hard drives operating as one drive for optimized data RW performance. It needs two unused drives to build this operation.

RAID 1 (Mirroring): Copies the data from first drive to second drive for data security, and if one drive fails, the system would access the applications to the workable drive. It needs two unused drives or one used and one unused drive to build this operation. The second drive must be the same or larger size than first one.

JBOD (Span): As different as RAID 0, the JBOD combines two disks as one without any fault tolerance and I/O performance enhancement.

To build Serial ATA disk array, please press <TAB> while booting up the system before entering OS, and follow the instructions to edit the RAID function.

(Selectable Functions)

(Option Instruction)

Channel	Drive Name	Array Name	Mode	Size(GB)	Status
Serial_Ch0	Master ST3120026AS	ARRAY 0	SATA	111.79	Boot
Serial_Ch1	Master Maxtor 6Y120W0	ARRAY 0	SATA	114.49	Boot

(Disk Statement)

You also can edit disk array under OS, please install the VIA RAID Utility in the driver CD.

(To getting start, please click here to learn more information)

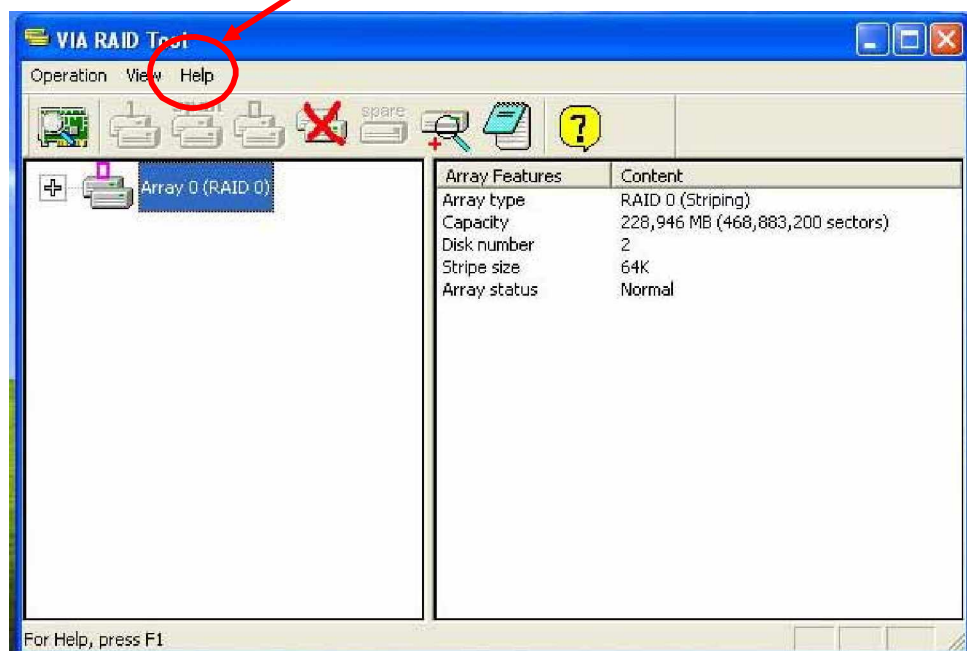

(Click here to build RAID 0)

(Click here to build RAID JBOD)

(Click here to build RAID 0)

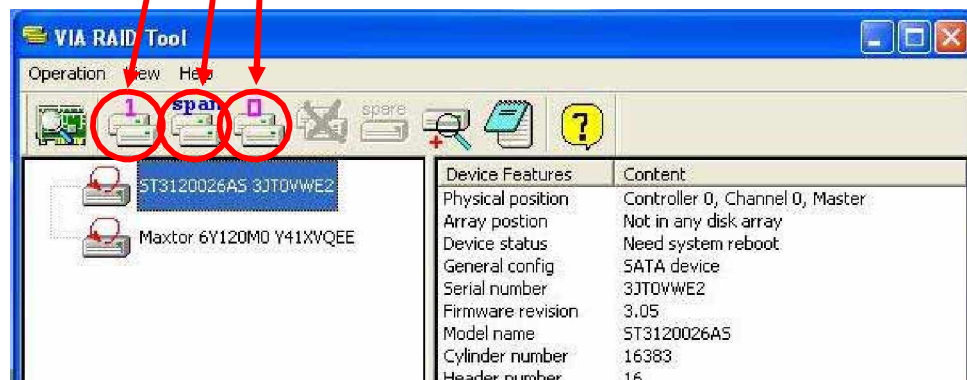

3.2 <Audio Configuration>

The board provides 5.1 channel audio interface with driver installed, please install the VIA audio driver in the CD before getting start to enjoy the 5.1 channel sound system.

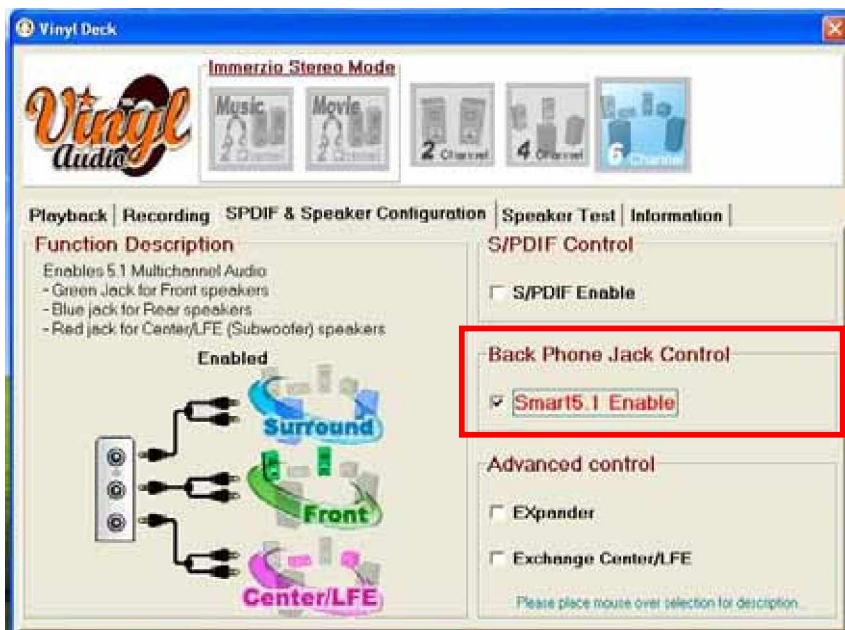

(To enable 5.1-channel sound mode)



Chapter 4 <BIOS Setup>

The motherboard uses the Award BIOS for the system configuration. The Award BIOS in the single board computer is a customized version of the industrial standard BIOS for IBM PC AT-compatible computers. It supports Intel x86 and compatible CPU architecture based processors and computers. The BIOS provides critical low-level support for the system central processing, memory and I/O sub-systems.

The BIOS setup program of the single board computer let the customers modify the basic configuration setting. The settings are stored in a dedicated battery-backed memory, NVRAM, retains the information when the power is turned off. If the battery runs out of the power, then the settings of BIOS will come back to the default setting.

The BIOS section of the manual is subject to change without notice and is provided here for reference purpose only. The settings and configurations of the BIOS are current at the time of print, and therefore they may not be exactly the same as that displayed on your screen.

To activate CMOS Setup program, press key immediately after you turn on the system. The following message "Press DEL to enter SETUP" should appear in the lower left hand corner of your screen. When you enter the CMOS Setup Utility, the Main Menu will be displayed as **Figure 4-1**. You can use arrow keys to select your function, press <Enter> key to accept the selection and enter the sub-menu.

Figure 4-1 CMOS Setup Utility Main Screen

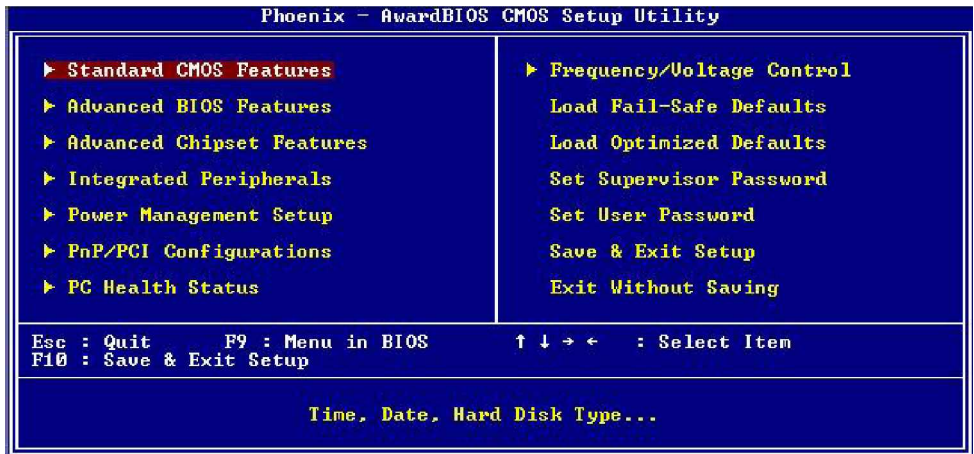

Appendix A <I/O Port Pin Assignment>

A.1 <IDE Port>

Connector: IDE1

Type: 40-pin (20 x 2) box header



Pin	Description	Pin	Description
1	Reset	2	Ground
3	D7	4	D8
5	D6	6	D9
7	D5	8	D10
9	D4	10	D11
11	D3	12	D12
13	D2	14	D13
15	D1	16	D14
17	D0	18	D15
19	Ground	20	VCC
21	REQ	22	Ground
23	IOW-/STOP	24	Ground
25	IOR-/HDMARDY	26	Ground
27	IRDY/DDMARDY	28	IDESEL
29	DACK-	30	Ground
31	IRQ	32	N/C
33	A1	34	CBLID
35	A0	36	A2
37	CS0 (MASTER CS)	38	CS1 (SLAVE CS)
39	LED ACT-	40	Ground

Connector: **IDE2**

Type: 44-pin (22 x 2) box header



Pin	Description	Pin	Description
1	Reset	2	Ground
3	D7	4	D8
5	D6	6	D9
7	D5	8	D10
9	D4	10	D11
11	D3	12	D12
13	D2	14	D13
15	D1	16	D14
17	D0	18	D15
19	Ground	20	N/C
21	REQ	22	Ground
23	IOW-/STOP	24	Ground
25	IOR-/HDMARDY	26	Ground
27	IORDY/DDMARDY	28	Ground
29	DACK-	30	Ground
31	IRQ	32	N/C
33	A1	34	SD
35	A0	36	A2
37	CS1	38	CS3
39	ASP1	40	Ground
41	Vcc	42	Vcc
43	Ground	44	Ground

A.2 <Floppy Port>

Connector: **FDD**



Type: 26-pin connector

Pin	Description	Pin	Description
1	VCC	2	INDEX
3	VCC	4	DRV0
5	VCC	6	DSKCHG
7	DRV1	8	N/C
9	MTR1	10	MTR0
11	RPM	12	DIR
13	N/C	14	STEP
15	Ground	16	WRITE DATA
17	Ground	18	WRITE GATE
19	N/C	20	TRACK 0
21	N/C	22	WRPTR
23	Ground	24	RDATA-
25	Ground	26	SEL

A.3 <IrDA Port>

Connector: **CN_IR**



Type: 5-pin header for SIR Ports

Pin	Description
1	Vcc
2	N/C
3	IRRX
4	Ground
5	IRTX

A.4 < VGA Port >

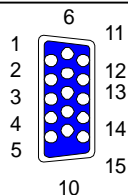

Connector: **VGA**

Type: 15-pin D-sub female connector on bracket

Pin	Description	Pin	Description	Pin	Description
1	RED	6	Ground	11	N/C
2	GREEN	7	Ground	12	5VCDA
3	BLUE	8	Ground	13	HSYNC
4	N/C	9	LVGA5V	14	VSYNC
5	Ground	10	Ground	15	5VCLK

A.5 <Serial ATA Port>

Connector: **CN_SATA1/2**

Type: 7-pin wafer connector

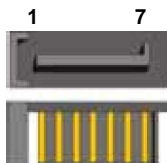

1	2	3	4	5	6	7
GND	RSATA_TXP1	RSATA_TXN1	GND	RSATA_RXN1	RSATA_RXP1	GND

A.6 <Serial Port>

Connector: **COM1/2**

Type: 9-pin D-sub male connector on bracket

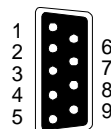

Pin	Description	Pin	Description
1	DCD	6	DSR
2	SIN	7	RTS
3	SO	8	CTS
4	DTR	9	RI
5	Ground		

A.8 <LAN Port>

Connector: **RJ45_1/2**

Type: RJ45 connector with LED on bracket



Pin	1	2	3	4	5	6	7	8
Description	TX+	TX-	RX+	N/C	N/C	RX-	N/C	N/C

A.9 <PS/2 Keyboard & Mouse Port>

Connector: **Keyboard**

Type: 6-pin Mini-DIN connector on bracket



Pin	1	2	3	4	5	6
Description	N/C	KB_CK	BVCC	IOGND	N/C	KB_DT

Connector: **Mouse**

Type: 6-pin Mini-DIN connector on bracket

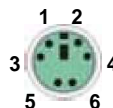

Pin	1	2	3	4	5	6
Description	N/C	MS_CK	BVCC	IOGND	N/C	MS_DT

(This Page is Left for Blank)

Appendix B <Flash BIOS>

B.1 BIOS Auto Flash Tool

The board is based on Award BIOS and can be updated easily by the BIOS auto flash tool. You can download the tool online at the address below:

<http://www.award.com>

File name of the tool is "awdf flash.exe", it's the utility that can write the data into the BIOS flash ship and update the BIOS.

B.2 Flash Method

1. Please make a bootable floppy disk.
2. Get the last .bin files you want to update and copy it into the disk.
3. Copy awardflash.exe to the disk.
4. Power on the system and flash the BIOS. (Example: C:/ awardflash XXX.bin)
5. Re-star the system.

(This Page is Left for Blank)

Appendix C <System Resources>

C.1 <I/O Port Address Map>

Address Range	Devices
x0000 - x000F	Direct memory access controller
x0010 - x001F	Motherboard resources
x0020 - x0021	Programmable interrupt controller
x0022 - x003F	Motherboard resources
x0040 - x0043	System timer
x0044 - x005F	Motherboard resources
x0060 - x0060	Standard 101/102-Key or Microsoft Natural Keyboard
x0061 - x0061	System speaker
x0062 - x0063	Motherboard resources
x0064 - x0064	Standard 101/102-Key or Microsoft Natural Keyboard
x0065 - x006F	Motherboard resources
x0070 - x0073	System CMOS/real time clock
x0074 - x007F	Motherboard resources
x0080 - x0090	Direct memory access controller
x0091 - x0093	Motherboard resources
x0094 - x009F	Direct memory access controller
x00A0 - x00A1	Programmable interrupt controller
x00A2 - x00BF	Motherboard resources
x00C0 - x00DF	Direct memory access controller
x00E0 - x00EF	Motherboard resources
x00F0 - x00FF	Numeric data processor
x0170 - x0177	VIA Bus Master PCI IDE Controller
x0170 - x0177	Secondary IDE controller (dual fifo)
x01F0 - x01F7	VIA Bus Master PCI IDE Controller
x01F0 - x01F7	Primary IDE controller (dual fifo)
x0200 - x0200	Gameport Joystick
x0201 - x0207	Gameport Joystick
x0294 - x0297	Motherboard resources
x02E8 - x02EF	Communications Port (COM4)
x02F8 - x02FF	Communications Port (COM2)
x0330 - x0331	MPU-401 Compatible
x0376 - x0376	VIA Bus Master PCI IDE Controller
x0376 - x0376	Secondary IDE controller (dual fifo)
x03B0 - x03BB	VIA/S3G UniChrome Pro IGP
x03C0 - x03DF	VIA/S3G UniChrome Pro IGP
x03E8 - x03EF	Communications Port (COM3)
x03F2 - x03F5	Standard Floppy Disk Controller
x03F6 - x03F6	VIA Bus Master PCI IDE Controller

Address Range	Devices
x03F6 - x03F6	Primary IDE controller (dual fifo)
x03F7 - x03F7	Standard Floppy Disk Controller
x03F8 - x03FF	Communications Port (COM1)
x0400 - x047F	Motherboard resources
x04D0 - x04D1	Motherboard resources
x0500 - x050F	Motherboard resources
x0CF8 - x0CFF	PCI bus
xD000 - xD0FF	Realtek RTL8139/810x Family Fast Ethernet NIC
xD400 - xD4FF	VIA SATA RAID Controller
xD800 - xD8FF	Vinyl AC'97 Codec Combo Driver (WDM)
xDC00 - xDCFF	VIA Rhine II Fast Ethernet Adapter
xE000 - xE007	VIA SATA RAID Controller
xE100 - xE103	VIA SATA RAID Controller
xE200 - xE20F	VIA SATA RAID Controller
xE300 - xE37F	PCI OHCI Compliant IEEE 1394 Host Controller
xE400 - xE407	Primary IDE controller (dual fifo)
xE400 - xE40F	VIA Bus Master PCI IDE Controller
xE408 - xE40F	Secondary IDE controller (dual fifo)
xE500 - xE51F	VIA Tech 3038 PCI to USB Universal Host Controller
xE600 - xE61F	VIA Tech 3038 PCI to USB Universal Host Controller
xE700 - xE71F	VIA Tech 3038 PCI to USB Universal Host Controller
xE800 - xE81F	VIA Tech 3038 PCI to USB Universal Host Controller
xE900 - xE907	VIA SATA RAID Controller
xEA00 - xEA03	VIA SATA RAID Controller

C.2 <Memory Address Map>

Range	Devices
x00000000 - x0009FFFF	System board extension for ACPI BIOS
x000A0000 - x000AFFFF	VIA/S3G UniChrome Pro IGP
x000B0000 - x000BFFFF	VIA/S3G UniChrome Pro IGP
x000C0000 - x000CEFFF	VIA/S3G UniChrome Pro IGP
x000CF000 - x000CFFFF	System board extension for ACPI BIOS
x000F0000 - x000F7FFF	System board extension for ACPI BIOS
x000F8000 - x000FBFFF	System board extension for ACPI BIOS
x000FC000 - x000FFFFFF	System board extension for ACPI BIOS
x00100000 - x1BDEFFFF	System board extension for ACPI BIOS
x1BDF0000 - x1BDFFFFF	System board extension for ACPI BIOS
xE8000000 - xEFFFFFFF	VIA Standard Host Bridge
xF0000000 - xF3FFFFFF	VIA CPU to AGP2.0/AGP3.0 Controller
xF0000000 - xF3FFFFFF	VIA/S3G UniChrome Pro IGP
xF4000000 - xF4FFFFFF	VIA/S3G UniChrome Pro IGP
xF4000000 - xF5FFFFFF	VIA CPU to AGP2.0/AGP3.0 Controller
xF5000000 - xF500FFFF	VIA/S3G UniChrome Pro IGP
xF6000000 - xF60000FF	Realtek RTL8139/810x Family Fast Ethernet NIC
xF6001000 - xF60017FF	PCI OHCI Compliant IEEE 1394 Host Controller
xF6002000 - xF60020FF	VIA PCI to USB Enhanced Host Controller
xF6003000 - xF60030FF	VIA Rhine II Fast Ethernet Adapter
xFEC00000 - xFEC00FFF	System board extension for ACPI BIOS
xFEE00000 - xFEE00FFF	System board extension for ACPI BIOS
xFFFF80000 - xFFFFEFFFF	System board extension for ACPI BIOS
xFFFFF0000 - xFFFFFFFFF	System board extension for ACPI BIOS

C.3 <System IRQ & DMA Resource>

C.3.1 <IRQ>

IRQ Number	Devices
0	System timer
1	Standard 101/102-Key or Microsoft Natural Keyboard
2	Programmable interrupt controller
3	Communications Port (COM2)
4	Communications Port (COM4)
4	Communications Port (COM3)
4	Communications Port (COM1)
5	VIA Rhine II Fast Ethernet Adapter
5	VIA Tech 3038 PCI to USB Universal Host Controller
5	VIA Tech 3038 PCI to USB Universal Host Controller
5	VIA/S3G UniChrome Pro IGP
5	ACPI IRQ Holder for PCI IRQ Steering
6	Standard Floppy Disk Controller
7	Vinyl AC'97 Codec Combo Driver (WDM)
7	VIA PCI to USB Enhanced Host Controller
7	Realtek RTL8139/810x Family Fast Ethernet NIC
7	ACPI IRQ Holder for PCI IRQ Steering
8	System CMOS/real time clock
9	SCI IRQ used by ACPI bus
10	MPU-401 Compatible
11	VIA Tech 3038 PCI to USB Universal Host Controller
11	VIA Tech 3038 PCI to USB Universal Host Controller
11	VIA SATA RAID Controller
11	PCI OHCI Compliant IEEE 1394 Host Controller
11	ACPI IRQ Holder for PCI IRQ Steering
11	ACPI IRQ Holder for PCI IRQ Steering

IRQ Number	Devices
12	PS/2 Compatible Mouse Port
13	Numeric data processor
14	Primary IDE controller (dual fifo)
14	VIA Bus Master PCI IDE Controller
15	Secondary IDE controller (dual fifo)
15	VIA Bus Master PCI IDE Controller

C.3.2 <DMA>

Channel	Device
2	Standard Floppy Disk Controller
4	Direct memory access controller
0	(free)
1	(free)
3	(free)
5	(free)
6	(free)
7	(free)

(This Page is Left for Blank)

Appendix D <Power Consumption Test>

Hardware		
CPU	Embedded VIA C3 1.0GHz	
Memory	HYNIX DDR400 1GB	
HDD	Seagate ST340014A	(not counted)
CDROM	SONY DDU1621 DVD-ROM	(not counted)
Power Supply	AOPEN FSP300-60ATV	
Software		
OS	Windows XP SP1 English Version	
Application	3DMARK 2001	
Test Result		
3.3V	0.3A	0.99W
5V	3.5A	17.5W
12V	0.2A	2.4W

Hardware		
CPU	Embedded VIA C3 1.0GHz	
Memory	HYNIX DDR400 1GB	
HDD	Seagate ST340014A	(not counted)
CDROM	SONY DDU1621 DVD-ROM	(not counted)
Power Supply	AOPEN FSP300-60ATV	
Mini-AGP	MA-ATI	
Software		
OS	Windows XP SP1 English Version	
Application	3DMARK 2003	
Test Result		
3.3V	1.2A	3.96W
5V	4.3A	21.5W
12V	0.3A	3.6W

Contact Information

Thank you for purchasing from Global American Inc. We will stand by our slogan, "Integration with Integrity". Please let us know how your product is performing and if we can help you with anything!



Address	17 Hampshire Drive Hudson, NH 03051
TEL	(800) 833 8999
FAX	(603) 886 4545
Website	http://www.globalamericaninc.com
E-mail	salesinfo@globalamericaninc.com (sales) support@globalamericaninc.com (tech supports)

Please consult our web page for product "Terms and Conditions" and our "Warranty and Return Policy".