



User's Manual

2801290

Version 1.0

Table of Contents

How to Use This Manual

Chapter 1 System Overview.....	1-1
1.1 Introduction.....	1-1
1.2 Check List.....	1-2
1.3 Product Specification.....	1-3
1.3.1 Mechanical Drawing.....	1-5
1.4 System Architecture.....	1-6
Chapter 2 Hardware Configuration.....	2-1
2.1 Jumper Setting.....	2-1
2.2 Connector Allocation.....	2-5
Chapter 3 System Installation.....	3-1
3.1 Intel® LGA 775 Processor.....	3-1
3.2 Main Memory.....	3-3
3.3 Installing the Single Board Computer.....	3-4
3.3.1 Chipset Component Driver.....	3-4
3.3.2 Intel Integrated Graphics GMCH Chip.....	3-4
3.3.3 On-board Fast Ethernet Controller.....	3-5
3.3.4 On-board AC-97 Audio Device.....	3-5
3.3.5 Intel Matrix Storage Manager Device.....	3-6
3.3.6 AMT Function Installation.....	3-7
3.4 Clear CMOS Operation.....	3-7
3.5 WDT Function.....	3-8
3.6 GPIO.....	3-9
3.6.1 Pin assignment.....	3-10
3.6.2 2801290 GPIO Programming Guide.....	3-10
3.6.3 Example.....	3-13
Chapter 4 BIOS Setup Information.....	4-1
4.1 Entering Setup.....	4-1
4.2 Main Menu.....	4-2
4.3 Standard CMOS Setup Menu.....	4-3
4.4 IDE Adaptors Setup Menu.....	4-5
4.5 Advanced BIOS Feature.....	4-7
4.6 Advanced Chipset Feature.....	4-13
4.7 Integrated Peripherals.....	4-15
4.8 Power Management Setup.....	4-21
4.9 PnP/PCI Configurations.....	4-25
4.10 PC Health Status.....	4-27
4.11 Frequency/Voltage Control.....	4-28
4.12 Default Menu.....	4-28
4.13 Supervisor/User Password Setting.....	4-29
4.14 Exiting Selection.....	4-30
Chapter 5 Troubleshooting.....	5-1
5.1 Hardware Quick Installation.....	5-1
5.2 Frequency Asking Questions (FAQ).....	5-2
5.3 BIOS Setting.....	5-3

How to Use This Manual

The manual describes how to configure your 2801290 system to meet various operating requirements. It is divided into five chapters, with each chapter addressing a basic concept and operation of Single Board Computer.

Chapter 1 : System Overview. Presents what you have in the box and give you an overview of the product specifications and basic system architecture for this series model of single board computer.

Chapter 2 : Hardware Configuration. Shows the definitions and locations of Jumpers and Connectors that you can easily configure your system.

Chapter 3 : System Installation. Describes how to properly mount the CPU, main memory and Compact Flash to get a safe installation and provides a programming guide of Watch Dog Timer function.

Chapter 4 : BIOS Setup Information. Specifies the meaning of each setup parameters, how to get advanced BIOS performance and update new BIOS. In addition, POST checkpoint list will give users some guidelines of trouble-shooting.

Chapter 5 : Troubleshooting. Provides various useful tips to quickly get 2801290 running with success. As basic hardware installation has been addressed in Chapter 3, this chapter will basically focus on system integration issues, in terms of backplane setup, BIOS setting, and OS diagnostics.

The content of this manual is subject to change without prior notice. These changes will be incorporated in new editions of the document. Global American, Inc. may make supplement or change in the products described in this document at any time.

Updates to this manual, technical clarification, and answers to frequently asked questions will be shown on the following web site : <http://www.globalamericaninc.com/>.

Chapter 1

System Overview

1.1 Introduction

Industrial motherboard users are often faced with the choice between powerful computing power and the high cost of the energy it consumes. And while thermal coolers are effective, the weight and size of the cooler itself can become a weak link in the system. Global American, Inc., a world-leading innovator in the Industrial PC (IPC), has a practical solution to this problem with its new 2801290 industrial motherboard.

The ATX form factor mainboard supports the energy-saving Intel® Core 2 Duo dual-core E6400 processor based on the latest Q965 Express chipset, which includes the Intel® Q965 Graphics and Memory Controller Hub and the Intel® I/O Controller Hub ICH8DO, and features a Intel® Graphics Media Accelerator 3000, dual-channel memory bandwidth as high as 12.8 GB, and dynamic video memory of 384 MB to enable enhanced gaming and video interaction. Available now, Global American, Inc. new 2801290 industrial ATX motherboard is the ideal solution for applications in the medical equipment, industrial automation, financial automation, process control, semiconductor equipment, and network security markets.

The new 2801290 industrial ATX motherboard provides enhanced video output. An on-board PCI Express x16 expansion slot supports the choice of an alternative graphics add-in card. Further expansion options include one PCI Express x1 slot, a PCI Express x4 slot, and four PCI slots to enrich the functionality of the customer's platform.

Feature List

- z Supports Intel® Core 2 Duo, Pentium® D, Pentium® 4, Celeron® D processor in an LGA775 socket equipped with dual core, Hyper-Threading, EM64T, EIST, and XD & VT technologies.
- z Four 240-pin DDR2 SDRAM DIMMM sockets, support for DDR2 1066/800/533 DIMMs, up to 8GB system memory.
- z Intel® Q965 integrated GMA 3000 on-board graphics interface and PCI Express x16 interface for latest external high-end graphic card. The PCI Express x16 slot can also be used for a second independent display such as TV & DVI when plugged with the ADD2/+ card.
- z One PCI Express x1, one PCI Express x4 and 4 PCI slots that cover most industry add-on cards; equipped single Gigabit Ethernet port.
- z Audio in/out, Watchdog timer; 8 USB 2.0 ports (four internal, four external).
- z IDE interface supports one IDE device or Compact Flash; five SATA 300 ports with Intel® Matrix Storage Technology.

1.2 Check List

The 2801290 package should cover the following basic items:

- 9 One 2801290 Industrial Mainboard
- 9 One I/O shield
- 9 One IDE cable
- 9 One SATA signal cable
- 9 One Installation Resources CD-Title

If any of these items is damaged or missing, please contact your vendor and keep all packing materials for future replacement and maintenance.

1.3 Product Specification

- z Main processor
CPU & Package: INTEL Core 2 Duo/Pentium D/Pentium 4/Celeron D processors, FSB: 1066/800/533MHz
- z BIOS
Award BIOS
- z Main Memory
 - Support dual-channel & signal channel DDR memory interface
 - Up to 8GB DDR2 800/667/533 SDRAM on four 240pin DIMM sockets
- z L2 Cache Memory
Included in processor
- z Chipset
INTEL Q965 chipset
- z Expansion Interface
 - Four 32-bit PCI expansion slots
 - One PCI Express x 4 slot
 - One PCI Express x 1 slot
 - One PCI Express x 16 slot
- z IDE Interface
Support only one IDE device (Master) with Ultra DMA/33/66/100
- z SATA Interface
Five SATA 300 ports
- z Serial Ports
Support four serial ports, (RS-232/TTL selectable x 1, RS-232/Powered selectable x 2, RS-232/422/485 selectable x 1)
- z IR Interface
IrDA 1.0 compatible
- z Parallel Port
Support one parallel port
- z USB Interface
Support eight USB (Universal Serial Bus) ports (four at rear I/O; four ports internal)
- z PS/2 Mouse and Keyboard Interface
Support dual 6-pin mini-DIN connector at rear I/O panel for PS/2 keyboard/mouse
- z Audio Interface
Connector and header of Line-in/Line-out/MIC for external and internal usage
- z Real Time Clock/Calendar (RTC)
Support Y2K Real Time Clock/Calendar with battery backup for 7-year data retention

- z Watchdog Timer
 - Support WDT function through software programming for enable/disable and interval setting
 - Generate system reset
- z On-board VGA
 - GMCH integrated Intel Graphics Media Accelerator 3000 (Intel GMA 3000)
 - Intel Dynamic Video Memory Technology (DVMT) 4.0 shares system memory up to 256MB
- z On-board Ethernet LAN
 - One Gigabit Ethernet (10/100/1000 Mbits/sec) LAN port
- z High Driving GPIO
 - Programmable 10-bit Digital I/O interface
- z Cooling Fans
 - Support one 4-pin power connector for CPU cooler and four 3-pin power connector for system fan
- z System Monitoring Feature
 - Monitor CPU temperature, system temperature and major power sources, etc
- z Outline Dimension (L X W):
 - 312.8mm (12.3") X 243.8mm (9.6")
- z Power Requirements:
 - Typical: 5V@4.0A; 12V@6.5A; 3.3V@3A
- z Configuration:
 - CPU 12V @7.6A
 - +12V (System) @1.2A
 - +5V (System) @2.9A
 - Test configuration:
 - CPU: Intel(R) Pentium 4 3.4GHZ (200x17)
 - Memory: Transcend (SAMSUNG K4T1G084QA-ZCD5) 2GBx4 DDR2 533
 - HDD: Seagate-ST3120813AS (120GB)
 - CD-ROM: PLEXTOR-PX-755SA
 - OS: Windows XP Pro
 - Test Programs: Burning Test V4.0
 - Run Time: 30 minutes
- z Operating Temperature:
 - 0°C ~ 55°C
- z Storage Temperature:
 - 20°C ~ 80°C
- z Relative Humidity:
 - 5% ~ 90%, non-condensing

1.3.1 Mechanical Drawing

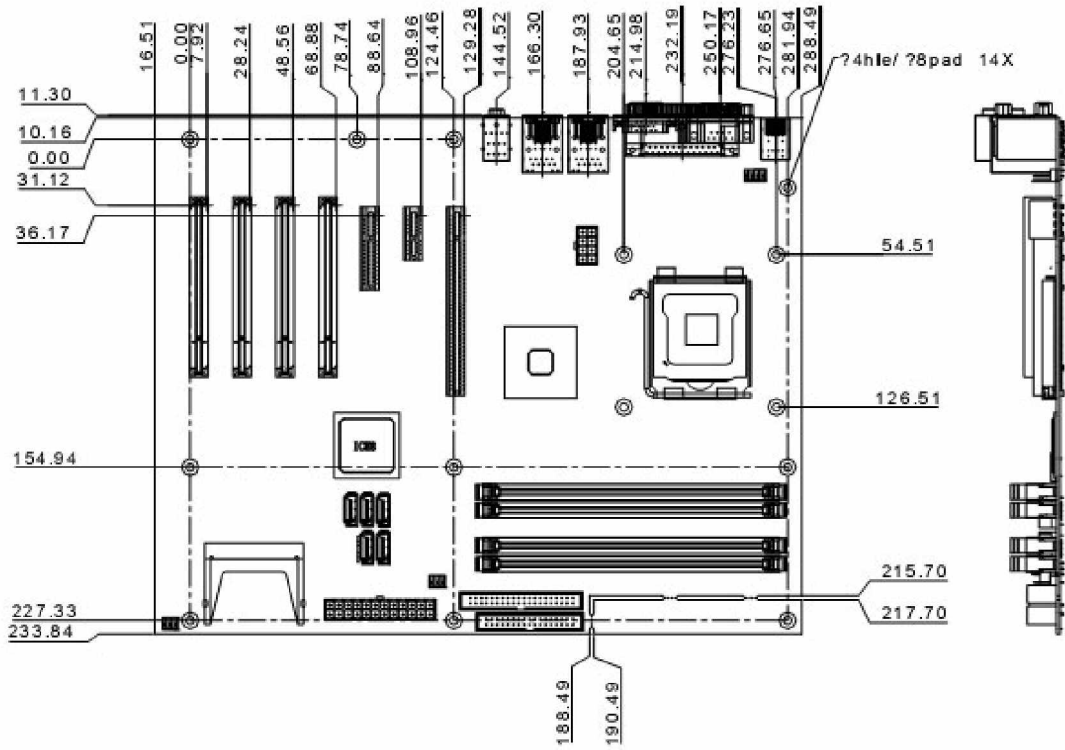

1.4 System Architecture

2801290 includes INTEL Q965 chipset, it supports the latest INTEL Core 2 Duo processors with 1066MHz front side bus; up to 8GB DDR2 800 SDRAM system memory in four DIMM sockets; five SATA ports; one IDE port and eight USB 2.0 on 2801290.

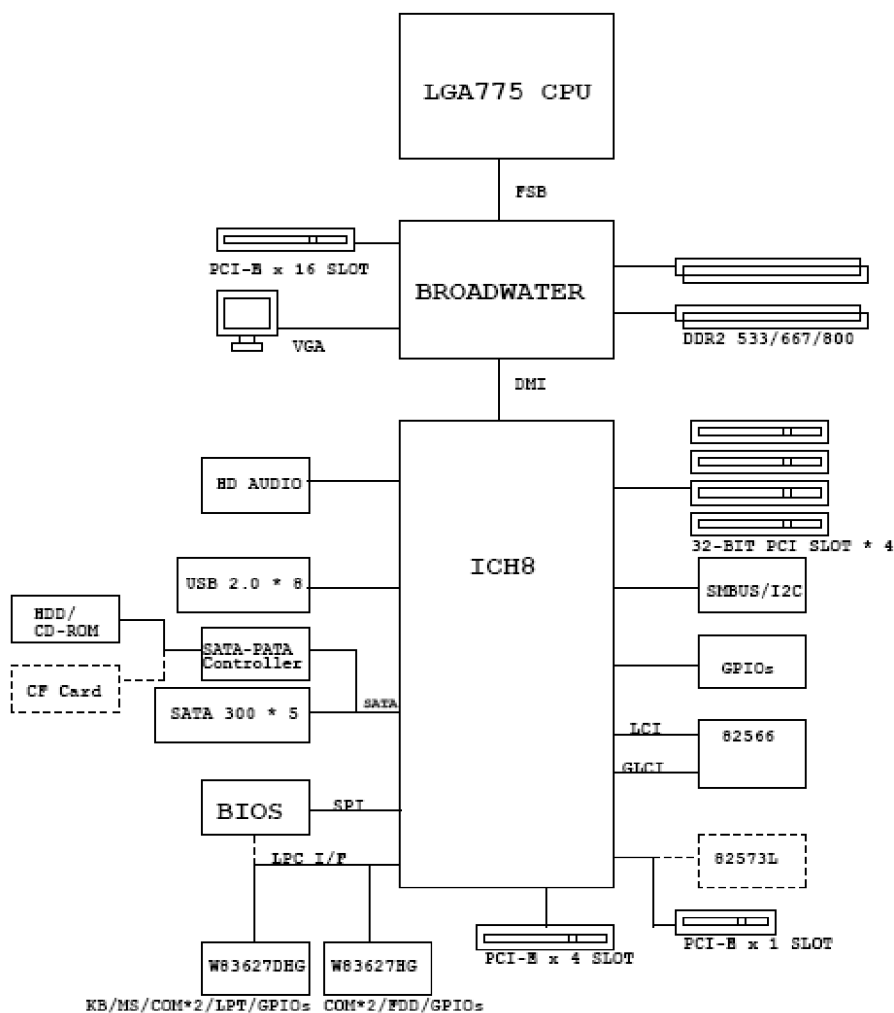

2801290 Block Diagram

Chapter 2 Hardware Configuration

This chapter indicates jumpers', headers' and connectors' locations. Users may find useful information related to hardware settings in this chapter. The default settings are indicated with a star sign (*).

2.1 Jumper Setting

In order to customize 2801290's features for users, in the following sections, Short means covering a jumper cap over jumper pins; Open or N/C (Not Connected) means removing a jumper cap from jumper pins. Users can refer to Figure 2-1 for the Jumper locations.

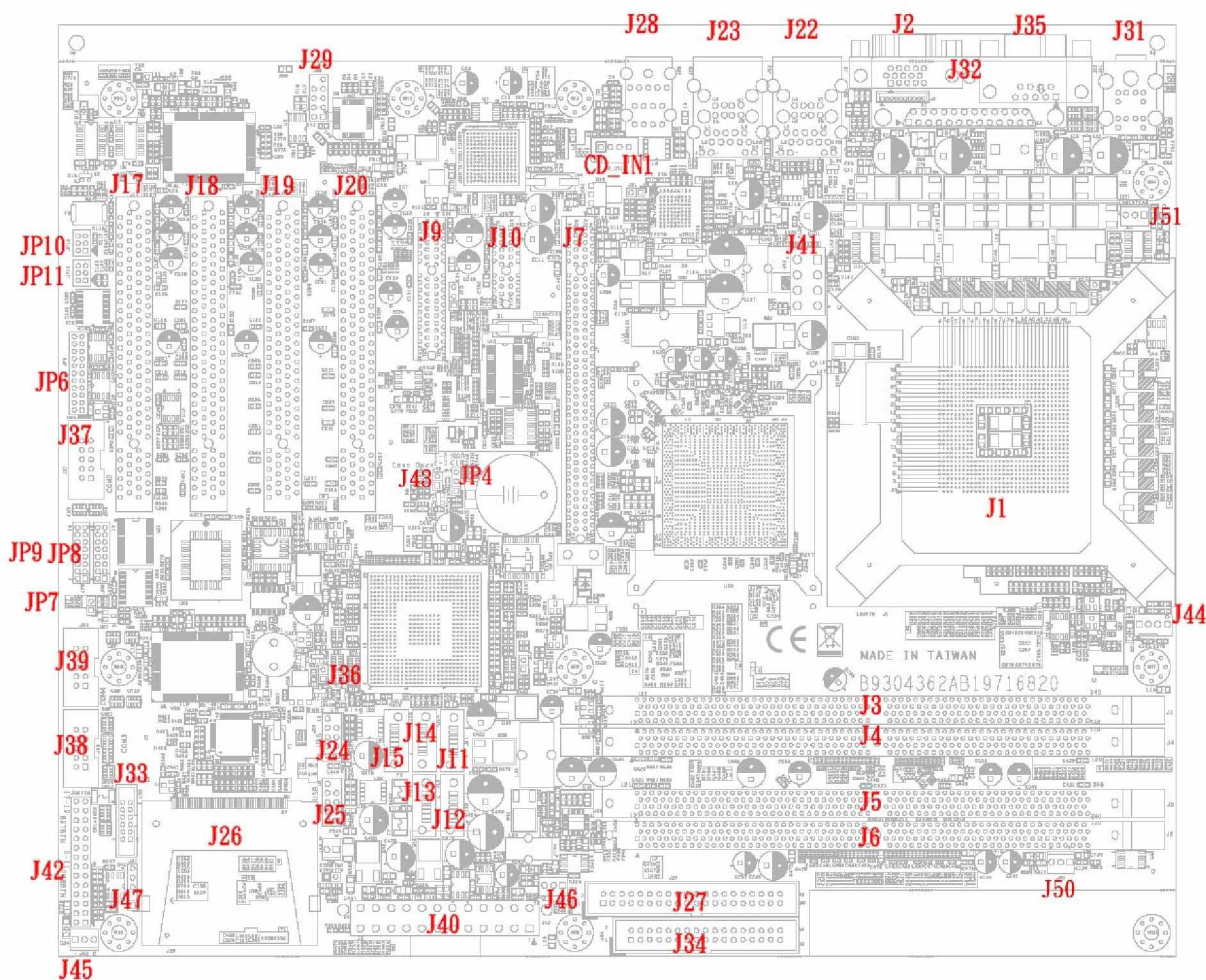
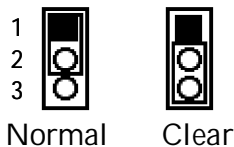

Figure 2-1 2801290 Jumper & Connector Location

JP4: CMOS Normal / Clear Jumper



JP4	Function
1-2 Short	Clear CMOS Disable (Normal) Ĩ
2-3 Short	Clear CMOS Enable (Clear)

JP6: COM1(J35) Interface Selection

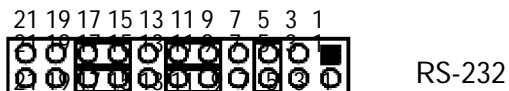

22 20 18 16 14 12 10 8 6 4 2

21 19 17 15 13 11 9 7 5 3 1

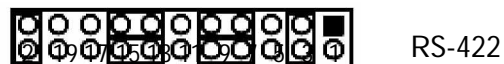

22 20 18 16 14 12 10 8 6 4 2

21 19 17 15 13 11 9 7 5 3 1

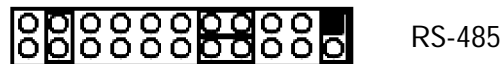

22 20 18 16 14 12 10 8 6 4 2

JP6	Function
5-6,9-11,10-12,15-17,16-18 Short	RS-232 Ĩ
3-4,7-9,8-10,13-15,14-16,21-22 Short	RS-422
1-2,7-9,8-10,19-20 Short	RS-485

JP7, JP8, JP9: COM2(J37) RS232/TTL Interface Selection

RS-232 Mode: 1

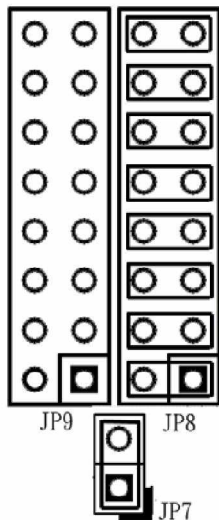

JP7	JP8	JP9
1-2 Short	1-2,3-4,5-6,7-8,9-10,11-12,13-14,15-16 Short	All Open

TTL Mode:

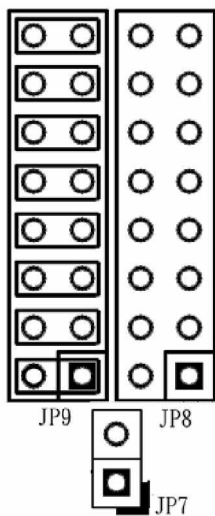

JP7	JP8	JP9
Open	All Open	1-2,3-4,5-6,7-8,9-10,11-12,13-14,15-16 Short

JP10: COM4(J39) RS232/Powered +12V/Powered +5V Interface Selection

RS232 Mode:

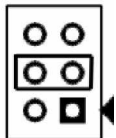

JP10	Function
3-4 Short	RS-232 ĩ

Powered +5V RS232 Mode:

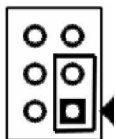

JP10	Function
1-3 Short	Powered +5V RS-232

Powered +12V RS232 Mode:

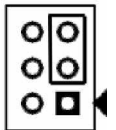

JP10	Function
3-5 Short	Powered +12V RS-232

JP11: COM3(J38) RS232/Powered +12V/Powered +5V Interface Selection

RS232 Mode:

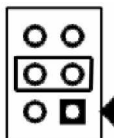

JP11	Function
3-4 Short	RS-232 ĩ

Powered +5V RS232 Mode:

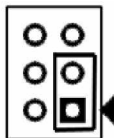

JP11	Function
1-3 Short	Powered +5V RS-232

Powered +12V RS232 Mode:

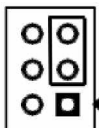

JP10	Function
3-5 Short	Powered +12V RS-232

2.2 Connector Allocation

I/O peripheral devices are connected to the interface connectors

Connector	Description	Remark
J1	LGA775 CPU socket	
J2	VGA output connector	
J3	DDR2 DIMM socket 1	
J4	DDR2 DIMM socket 2	
J5	DDR2 DIMM socket 3	
J6	DDR2 DIMM socket 4	
J7	PCI express x16 slot	
J9	PCI express x4 slot	
J10	PCI express x1 slot (Optional)	
J11	SATA connector 1	
J12	SATA connector 2	
J13	SATA connector 3	
J14	SATA connector 4	
J15	SATA connector 5	
J17	PCI 32 slot 1	
J18	PCI 32 slot 2	
J19	PCI 32 slot 3	
J20	PCI 32 slot 4	
J22	USB 0/6 connector; LAN RJ-45 connector 1	

J23	USB 1/7 connector; LAN RJ-45 connector 2 (LAN RJ-45 connector 2 Optional)	
J24	USB 2/8 connector	
J25	USB 3/9 connector	
J26	Compact flash socket	
J27	IDE connector	
J28	Audio jack (Line in/Line out/Mic in)	
J29	Internal audio connector (Line in/Line out/Mic in)	
J31	PS/2 keyboard mouse connector	
J32	Printer port	
J33	5-bit GPIO connector	
J34	Floppy connector	
J35	COM port 1	
J36	Wake-on-ring header	
J37	COM port 2	
J38	COM port 3	
J39	COM port 4	
J40	ATX power connector	
J41	+12V CPU power connector	
J42	Front panel control and LED header	
J43	Case open header	
J44	CPU fan connector	
J45	System fan connector 1	
J46	System fan connector 2	
J47	SMBus connector	
J50	System fan connector 3	
J51	System fan connector 4	
CD_IN1	CD-ROM analog audio input connector	

Pin Assignments of Connectors

J2: VGA Output Connector

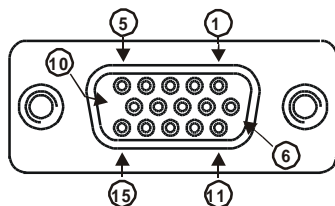

PIN No.	Signal Description	PIN No.	Signal Description
1	RED	2	GREEN
3	BLUE	4	ID0
5	Ground	6	Ground
7	Ground	8	Ground
9	NC	10	Ground
11	ID1	12	DCCDATA
13	HSYNC	14	VSYNC
15	DDCCLK		

J24: USB 2/8 connector

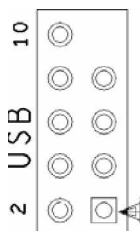

PIN No.	Signal Description	PIN No.	Signal Description
1	+5V	2	+5V
3	DATA-	4	DATA-
5	DATA+	6	DATA+
7	Ground	8	Ground
		10	NC

J25: USB 3/9 connector

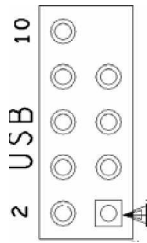

PIN No.	Signal Description	PIN No.	Signal Description
1	+5V	2	+5V
3	DATA-	4	DATA-
5	DATA+	6	DATA+
7	Ground	8	Ground
		10	NC

J28: Audio Jack

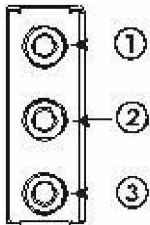

PIN No.	Signal Description
1 (Blue)	Line In
2 (Lime)	Line Out
3 (Pink)	Mic In

J29: Internal Audio Connector

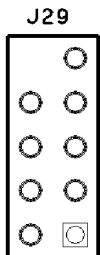

	Signal Description	PIN No.	Signal Description
1	Mic In	2	NC
3	Line In (Left)	4	GND
5	Line In (Right)	6	GND
7	Line Out (Left)	8	GND
9	Line Out (Right)		

J32: Printer Port

Pin No.	Signal Description	Pin No.	Signal Description
1	Strobe#	14	Auto Form Feed#
2	Data0	15	Error#
3	Data1	16	Initialization#
4	Data2	17	Printer Select In#
5	Data3	18	Ground
6	Data4	19	Ground
7	Data5	20	Ground
8	Data6	21	Ground
9	Data7	22	Ground
10	ACK#	23	Ground
11	Busy	24	Ground
12	Paper Empty	25	Ground
13	Printer Select	26	NC

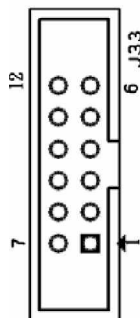
J33: 5-bit GPIO

PIN No.	Signal Description	PIN No.	Signal Description
1	GPIO10 (From SUPER I/O 2)	2	GPIO11 (From SUPER I/O 2)
3	GPIO12 (From SUPER I/O 2)	4	GPIO13 (From SUPER I/O 2)
5	GPIO14 (From SUPER I/O 2)	6	Ground
7	GPIO15 (From SUPER I/O 2)	8	GPIO16 (From SUPER I/O 2)
9	GPIO17 (From SUPER I/O 2)	10	GPIO30 (From SUPER I/O 1)
11	GPIO31 (From SUPER I/O 1)	12	+5V

J34: Floppy Connector

PIN No.	Signal Description	PIN No.	Signal Description
1	Ground	2	Density Select 0
3	Ground	4	N/C
5	Ground	6	N/C
7	Ground	8	INDEX#
9	Ground	10	Motor ENA#
11	Ground	12	N/C
13	Ground	14	Drive Select A#
15	Ground	16	N/C
17	Ground	18	Direction#
19	Ground	20	Step#
21	Ground	22	Write Data#
23	Ground	24	Write Gate#
25	Ground	26	Track 0#
27	Ground	28	Write Protect#
29	N/C	30	Read Data#
31	Ground	32	Head Select#
33	N/C	34	Disk Change#

J35: COM port 1

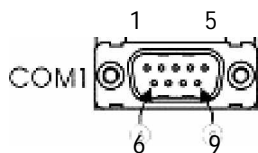

PIN No.	Signal Description		
	RS-232	RS-422	RS-485
1	DCD (Data Carrier Detect)	TX-	DATA-
2	RXD (Receive Data)	TX+	DATA+
3	TXD (Transmit Data)	RX+	NC
4	DTR (Data Terminal Ready)	RX-	NC
5	GND (Ground)	GND	GND
6	DSR (Data Set Ready)	NC	NC
7	RTS (Request to Send)	NC	NC
8	CTS (Clear to Send)	NC	NC
9	RI (Ring Indicator)	NC	NC

J37: COM port 2

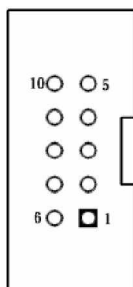

Pin No.	Signal Description
1	Data Carrier Detect
2	Receive Data
3	Transmit Data
4	Data Terminal Ready
5	Ground
6	Data Set Ready
7	Request To Send
8	Clear To Send
9	Ring Indicator
10	NC

J38/J39: COM port 3/4

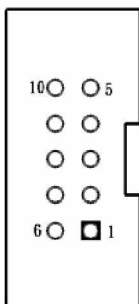

Pin No.	Signal Description
1	Data Carrier Detect
2	Receive Data
3	Transmit Data
4	Data Terminal Ready
5	Ground
6	Data Set Ready
7	Request To Send
8	Clear To Send
9	Ring Indicator (Powered +5V/+12V with JP10/JP11 selection)
10	NC

J41: +12V CPU Power Connector

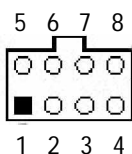

PIN No.	Signal Description
1	Ground
2	Ground
3	Ground
4	Ground
5	+12V
6	+12V
7	+12V
8	+12V

J42: Front panel control and LED header

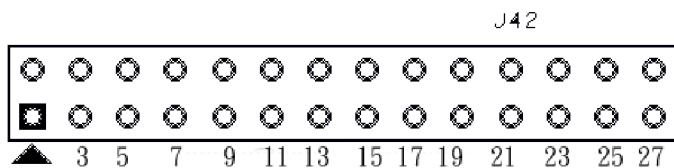

Signal Description		PIN No.	Signal Description	
1	HDD_LED+5V (150 ohm)	2	POWER_LED+5V (330 ohm)	
3	HDD_LED-	4	NC	
5	NC	6	Power_LED-	
7	NC	8	NC	
9	Power Button-	10	NC	
11	Power Button+ (10K Ohm)	12	NC	
13	Ground	14	+5V	
15	NC	16	Ground	
17	Reset Button+	18	Ground	
19	Reset Button-	20	PC Speaker	
21	LAN J22 ACT	22	LAN J23 ACT (Optional)	
23	LAN J22 ACT#	24	LAN J23 ACT# (Optional)	
25	LAN J22 LINK	26	LAN J23 LINK (Optional)	
27	LAN J22 LINK#	28	LAN J23 LINK# (Optional)	

J44: CPU fan connector

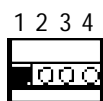

PIN No.	Signal Description
1	Ground
2	+12V
3	Sense (Fan Speed Detecting signal)
4	Control (PWM)

J45/J46/J50/J51: System fan connector 1/2/3/4

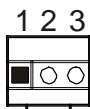

PIN No.	Signal Description
1	Ground
2	+12V
3	Fan Speed Detecting signal

J47: SMBus connector

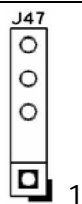

PIN No.	Signal Description
1	SMBus Clock
3	Ground
4	SMBus Data
5	+3.3V

CD_IN1: CD input connector

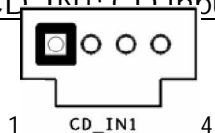

PIN No.	Signal Description
1	CD-IN Left
2	CD-Ground
3	CD-Ground
4	CD-IN Right

Chapter 3 System Installation

Chapter 3 instructs you to set up system; the additional information is enclosed to help you set up onboard PCI device and handle WDT operation in software programming.

3.1 Intel® LGA 775 Processor

Installing LGA 775 CPU

- 1) Lift the handling lever of CPU socket outwards and upwards to the other end.

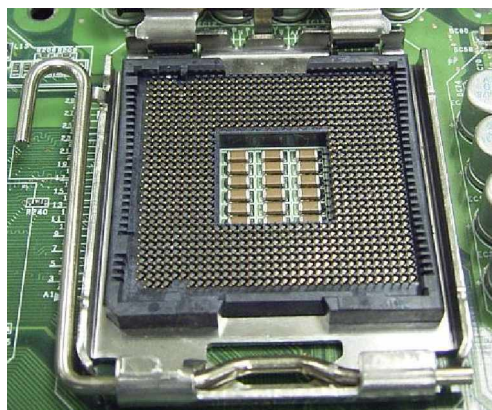

- 2) Align the processor pins with pinholes on the socket. Make sure that the notched corner or dot mark (pin 1) of the CPU corresponds to the socket's bevel end. Then press the CPU gently until it fits into place. If this operation is not easy or smooth, don't do it forcibly. You need to check and rebuild the CPU pin uniformly.

Triangle mark is meaning first pin position; kindly assemble and take aim at notch of top and bottom between CPU and socket.



- 3) Push down the lever to lock processor chip into the socket once CPU fits.
- 4) Follow the installation guide of cooling fan or heat sink to mount it on CPU surface and lock it on the LGA 775 package.
- 5) You should know LGA 775 processor need extra 12V power source.
Don't forget to connect 4pin (Or 8 pin) 12V connector to J41!

J41: 12V CPU Supplementary Connector

PIN No.	Signal Description
1	Ground*
2	Ground*
3	Ground
4	Ground
5	+12V*
6	+12V*
7	+12V
8	+12V

Note:

* When using 4-pin 12V CPU supplementary connector, plug the power connector into pins as marked.

Removing CPU

- 1) Unlock the cooling fan first.
- 2) Lift the lever of CPU socket outwards and upwards to the other end.
- 3) Carefully lifts up the existing CPU to remove it from the socket.
- 4) Follow the steps of installing a CPU to change to another one or place handling bar to close the opened socket.

CPU Application

Supports Intel® Core 2 Duo, Pentium® D, Pentium® 4, Celeron® D processor in an LGA775 socket equipped with dual core, Hyper-Threading, EM64T, EIST, and XD & VT technologies.

3.2 Main Memory

2801290 provides 4 x 240-pin DDR2-SDRAM DIMM sockets support 1.8V dual-channel DDR2 800/667/533 non-ECC DIMMs. The maximum memory size can be up to 8GB. Auto detecting memory clock is according to BIOS CMOS settings.

For system compatibility and stability, don't use memory module without brand. You can also use single-sided or double-sided DIMM in both slots.

Watch out the contact and lock integrity of memory module with socket, it will impact on the system reliability. Follow normal procedures to install your DRAM module into memory socket. Before locking, make sure that all modules have been fully inserted into the card slots.

Dual Channel DDR2 DIMMs

Dual Channel DDR2 memory technology doubles the bandwidth of memory bus. Adequate or higher bandwidth of memory than processor would increase system performance. To enable Dual Channel DDR2 memory technology, you have to install dual identical memory modules in both memory sockets. Following tables show bandwidth information of different processor and memory configurations.

	Dual Channel DDR Bandwidth	Single Channel DDR Bandwidth
800MHz	25.6 GB/s	12.8 GB/s
667 MHz	21.2 GB/s	10.6 GB/s
533 MHz	17.2 GB/s	8.6 GB/s

Note:

To maintain system stability, don't change any of DRAM parameters in BIOS setup to upgrade your system performance without acquiring technical information.

CPU FSB / Memory Frequency synchronization

Support different memory frequencies depending on the CPU front side bus and the type of DDR2 DIMM. Watch Out, it's meaning that memory maximum frequency on configuration, which is synchronization and based on CPU FSB.

CPU FSB	Memory Frequency
1066MHz	533 / 667 / 800MHz
800 MHz	533 / 667 / 800MHz
533 MHz	533 MHz

3.3 Installing the Single Board Computer

To install your 2801290 into standard chassis or proprietary environment, you need to perform the following:

Step 1: Check all jumpers setting on proper position.

Step 2: Install and configure CPU and memory module on right position.

Step 3: Place 2801290 into the dedicated position in your system. Step 4:

Attach cables to existing peripheral devices and secure it.

WARNING

Bus Interface Fully complies with PCI Local Bus specification V2.2 (support 4 master PCI slots); and Please follow section 3.31 to 3.3.5 instruction to install hardware driver.

3.3.1 Chipset Component Driver

The chipset on 2801290 is a new chipset that a few old operating systems might not be able to recognize. To overcome this compatibility issue, for Windows Operating Systems such as Windows 2000 /XP / Server 2003, please install its INF before any of other Drivers are installed. You can find very easily this chipset component driver in 2801290 CD-title.

3.3.2 Intel Integrated Graphics GMCH Chip

Using GMCH High performance graphic integrated chipset (Intel GMA 3000) is aimed to gain an outstanding graphic performance. Shared 128 accompany it to 256MB/Maximum system DDR2-SDRAM with Total Graphics Memory. This combination makes 2801290 an excellent piece of multimedia hardware.

With no additional video adaptor, this onboard video will usually be the system display output. By adjusting BIOS of "Advanced Chipset Feature" and set "PEG/Onchip VGA Control" to [PEG Port] (please kindly refer section 4.6 of chapter 4 configuration), and then the add-on PCI or PCI Express by 16 VGA Card can take over the system display.

Drivers Support

Please find hardware driver of 82965 GMCH in the 2801290 CD-title. Drivers support Windows 2000 / XP System 32-bit & Windows XP System 64-bit.

Windows 2000/XP (32bit): Please execute Install for Windows 2000/XP System 32-Bit file to start graphics driver installation.

Windows XP (64-bit): Please execute Install for Windows XP System 64-bit file to start graphics driver installation.

3.3.3 On-board Fast Ethernet Controller

Drivers Support

Please find Ethernet combination driver for operating Intel 82573L and 82566DM Gigabit LAN form 2801290 CD-title. The drivers support Windows 2000/XP System 32-Bit & Windows XP System 64-bit.

Windows 2000/XP (32bit): Please execute Install for Windows 2000/XP System 32-Bit file to start Intel LAN driver installation.

Windows XP (64-bit): Please execute Install for Windows XP System 64-bit file to "Ethernet\intel\intel_Gigabit_64bit\"; Pass below button into the dictionary.

LED Indicator (for LAN status)

2801290 provides three LED indicators to report Intel 82573L and 82566DM Gigabit Ethernet interfaces status. Please refer to the table below as a quick reference guide.

82566DM	Color	Name of LED	Operation of Ethernet Port		
			Linked	Active	
Status LED	Yellow	LAN Linked & Active LED	On	Blinking	
Speed LED	Orange	LAN speed LED	Giga Mbps	100 Mbps	10 Mbps
	Green		Orange	Green	Off

3.3.4 On-board AC-97 Audio Device

Please find Realtek ALC260 Audio driver of 2801290 CD-title. The drivers support Windows 2000/XP/Server 2003 .

3.3.5 Intel Matrix Storage Manager Device

Drivers Support

Please find utility tool for Intel ICH8DO of 2801290 CD-title. The drivers support Windows 2000/XP System 32-Bit & Windows XP System 64-bit.

Installing Serial ATA hard disks

The 2801290 supports Six Serial ATA hard disk drives. For optimal performance, install identical drives of the same model and capacity when creating a disk array.

To install the SATA hard disks for a RAID configuration:

1. Install the SATA hard disks into the drive bays.
2. Connect the SATA signal cables.
3. Connect a SATA power cable to the power connector on each drive.

Intel RAID configurations

This 2801290 supports RAID 0, RAID 1, RAID 5, RAID 10 (0+1) and Intel® Matrix Storage configurations for Serial ATA hard disks drives through the Intel ICH7R Southbridge chip.

RAID configurations

RAID 0 (Data striping) optimizes two identical hard disk drives to read and write data in parallel, interleaved stacks. Two hard disks perform the same work as a single drive but at a sustained data transfer rate, double that of a single disk alone, thus improving data access and storage. Use of two new identical hard disk drives is required for this setup.

RAID 1 (Data mirroring) copies and maintains an identical image of data from one drive to a second drive. If one drive fails, the disk array management software directs all applications to the surviving drive as it contains a complete copy of the data in the other drive. This RAID configuration provides data protection and increases fault tolerance to the entire system. Use two new drives or use an existing drive and a new drive for this setup. The new drive must be of the same size or larger than the existing drive.

RAID 10 is data striping and data mirroring combined without parity (redundancy data) having to be calculated and written. With the RAID 10 configuration you get all the benefits of both RAID 0 and RAID 1 configurations. Use four new hard disk drives or use an existing drive and three new drives for this setup.

RAID 5 stripes both data and parity information across three or more hard disk drives. Among the advantages of RAID 5 configuration include better HDD performance, fault tolerance, and higher storage capacity. The RAID 5 configuration is best suited for transaction processing, relational database applications, enterprise resource planning, and other business systems. Use a minimum of three identical hard disk drives for this setup.

Intel Matrix Storage Manager. The Intel® Matrix Storage technology supported by the ICH8DO chip allows you to create a RAID 0 and a RAID 1 set using only two identical hard disk drives. The Intel® Matrix Storage technology creates two partitions on each hard disk drive to create a virtual RAID 0 and RAID 1 sets. This technology also allows you to change the hard disk drive partition size without losing any data.

3.3.6 AMT Function Installation

A major barrier to greater IT efficiency has been removed by Intel® Active Management Technology (Intel® AMT) a feature on Intel® vPro™ technology. Using built-in platform capabilities and popular third-party management and security applications, Intel AMT allows IT to better Discover, Heal, and Protect their networked computing assets.

Installing ME (Management Engine) Drivers (which includes HECI Driver and LMS_SOL Driver) to operating PCI serial port and PCI simple communications controller.

3.4 Clear CMOS Operation

The following table indicates how to enable/disable CMOS Clear Function hardware circuit by putting jumpers at proper position.

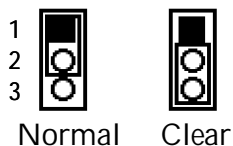

JP4	Function
1-2 Short	Normal Operation
2-3 Short	Clear CMOS contents

3.5 WDT Function

The working algorithm of the WDT function can be simply described as a counting process. The Time-Out Interval can be set through software programming. The availability of the time-out interval settings by software or hardware varies from boards to boards.

2801290 allows users control WDT through dynamic software programming. The WDT starts counting when it is activated. It sends out a signal to system reset or to non-maskable interrupt (NMI), when time-out interval ends. To prevent the time-out interval from running out, a re-trigger signal will need to be sent before the counting reaches its end. This action will restart the counting process. A well-written WDT program should keep the counting process running under normal condition. WDT should never generate a system reset or NMI signal unless the system runs into troubles.

The related Control Registers of WDT are all included in the following sample program that is written in C language. User can fill a non-zero value into the Time-out Value Register to enable/refresh WDT. System will be reset after the Time-out Value to be counted down to zero. Or user can directly fill a zero value into Time-out Value Register to disable WDT immediately. To ensure a successful accessing to the content of desired Control Register, the sequence of following program codes should be step-by-step run again when each register is accessed.

Additionally, there are maximum 2 seconds of counting tolerance that should be considered into user' application program. For more information about WDT, please refer to Winbond W83627DHG data sheet.

There are two PNP I/O port addresses that can be used to configure WDT,
1) 0x2E:EFIR (Extended Function Index Register, for identifying CR index number)
2) 0x2F:EFDR (Extended Function Data Register, for accessing desired CR)

Below are some example codes, which demonstrate the use of WDT.

```
// Enter Extended Function Mode
outp(0x002E, 0x87);
outp(0x002E, 0x87);
// Assign Pin 89 to be a WDTO
outp(0x002E, 0x2D);
outp(0x002F, inp(0x002F) & 0xFE);
// Select Logic Device 8
outp(0x002E, 0x07);
outp(0x002F, 0x08);
// Active Logic Device 8
outp(0x002E, 0x30);
outp(0x002F, 0x01);
```

```
// Select Count Mode
outp(0x002E, 0xF5);
outp(0x002F, (inp(0x002F) & 0xF7) | (Count-mode Register & 0x08));
// Specify Time-out Value
outp(0x002E, 0xF6);
outp(0x002F, Time-out Value Register);
// Disable WDT reset by keyboard/mouse interrupts
outp(0x002E, 0xF7);
outp(0x002F, 0x00);
// Exit Extended Function Mode
outp(0x002E, 0xAA);
```

Definitions of Variables:

Value of **Count-mode Register**:

- 1) 0x00 -- Count down in seconds (Bit3=0)
- 2) 0x08 -- Count down in minutes (Bit3=1)

Value of **Time-out Value Register**:

- 1) 0x00 -- Time-out Disable
- 2) 0x01~0xFF -- Value for counting down

3.6 GPIO

The 2801290 series provides 10 programmable general purpose input or output (GPIO) ports that can be individually configured to perform a simple basic I/O function. Users can configure each individual port to become an input or output port by programming register bit of I/O Selection. To invert port value, the setting of Inversion Register has to be made. Port values can be set to read or write through Data Register.

3.6.1 Pin assignment

J33: General Purpose I/O Connector

PIN No.	Signal Description
1	GPIO10 from SUPER I/O 2
2	GPIO11 from SUPER I/O 2
3	GPIO12 from SUPER I/O 2
4	GPIO13 from SUPER I/O 2
5	GPIO14 from SUPER I/O 2
6	Ground
7	GPIO15 from SUPER I/O 2
8	GPIO16 from SUPER I/O 2
9	GPIO17 from SUPER I/O 2
10	GPIO30 from SUPER I/O 1
11	GPIO31 from SUPER I/O 1
12	+5V

All General Purpose I/O ports can only apply to standard TTL \pm 5% signal level (0V/5V), and each source sink capacity up to 12mA.

3.6.2 2801290 GPIO Programming Guide

There are 10 GPIO pins on 2801290. These GPIO pins are from two SUPER I/Os which are W83627DHG and W83627HG respectively, and can be programmed as Input or Output direction. (**SUPER I/O1**: W83627DHG; **SUPER I/O2**: W83627HG)

J33 pin header is for 10 GPIO pins and its pin assignment as following :

J33_Pin1: from SUPER I/O2_GPIO10 with Ext. 4.7K Ohm Pull up
 J33_Pin2: from SUPER I/O2_GPIO11 with Ext. 4.7K Ohm Pull up
 J33_Pin3: from SUPER I/O2_GPIO12 with Ext. 4.7K Ohm Pull up
 J33_Pin4: from SUPER I/O2_GPIO13 with Ext. 4.7K Ohm Pull up
 J33_Pin5: from SUPER I/O2_GPIO14 with Ext. 4.7K Ohm Pull up
 J33_Pin7: from SUPER I/O2_GPIO15 with Ext. 4.7K Ohm Pull up
 J33_Pin8: from SUPER I/O2_GPIO16 with Ext. 4.7K Ohm Pull up
 J33_Pin9: from SUPER I/O2_GPIO17 with Ext. 4.7K Ohm Pull up
 J33_Pin10: from SUPER I/O1_GPIO30 with Ext. 4.7K Ohm Pull up
 J33_Pin11: from SUPER I/O1_GPIO31 with Ext. 4.7K Ohm Pull up
 <<<<< Be careful Pin6=GND , Pin12=+5V >>>>>

There are several Configuration Registers (CR) of W83627HG needed to be programmed to control the GPIO direction, and status(GPI)/value(GPO). CR00h ~ CR2F are common (global) registers to all Logical Devices (LD) in W83627HG and W83627DHG. CR07h contains the Logical Device Number that can be changed to access the LD as needed. LD7 contains the GPIO10~17 registers of SUPER I/O2. LD9 contains the GPIO30~31 registers of SUPER I/O1.

Programming Guide of GP10~GP17 from SUPER I/O2 (W83627HG):

Step1: CR2A_Bit [7.2].P[1,1,1,1,1]; to select multiplexed pins as GPIO10~17 pins

Step2: LD7_CR07h.P [07h]; Point to LD7

Step3: LD7_CR30h_Bit0.P1; Enable LD7

Step4: Select GPIO direction, Get Status or output value.

LD7_CRF0h; GPIO17 ~ 10 direction, 1 = input, 0 = output pin LD7_CRF2h.P [00h]; Let CRF1 (GPIO data port) non-invert to prevent from confusion

LD7_CRF1h; GPIO17~10 data port, for input pin, get status from the related bit, for output pin, write value to the related bit.

For example,

LD7_CRF0h_Bit4.P0; Let GPIO14 of SUPER I/O2 as output pin

LD7_CRF2h_Bit4.P0; Let CRF1_Bit4 non-inverted

LD7_CRF1h_Bit4.P0; Output "0" to GPIO14 pin (J33_Pin5)

LD7_CRF0h_Bit0.P1; Let GPIO10 as input pin

LD7_CRF2h_Bit0.P0; Let CRF1_Bit0 non-inverted

Read LD7_CRF1h_Bit0; Read the status from GPIO10 pin (J33_Pin10)

How to access W83627HG CR?

In 2801290, the EFER = 004Eh, and EFDR = 004Fh. EFER and EFDR are 2 IO ports needed to access W83627HG CR. EFER is the Index Port, EFDR is the Data Port.

CR index number needs to be written into EFER first,

Then the data will be read/written from/to EFDR.

To R/W W83627HG CR, it is needed to Enter/Enable Configuration Mode first. When completing the programming, it is suggested to Exit/Disable Configuration Mode.

Enter Configuration Mode: Write 87h to IO port EFER twice.

Exit Configuration Mode: Write AAh to IO port EFER.

Programming Guide of GP30~GP31 from SUPER I/O1 (W83627DHG):

Step1: LD9_CR07h.P[09h]; Point to LD9

Step2: LD9_CR30h_Bit0.P1; Enable LD9

Step3: Select GPIO direction, Get Status or output value.

LD9_CRF0h; GPIO31 ~ 30 direction, 1 = input, 0 = output pin LD9_CRF2h.P[00h]; Let CRF1 (GPIO data port) non-invert to prevent from confusion

LD9_CRF1h; GPIO31~30 data port, for input pin, get status from the related bit, for output pin, write value to the related bit.

For example,

LD9_CRF0h_Bit1.P0; Let GPIO31 of SUPER I/O1 as output pin

LD9_CRF2h_Bit1.P0; Let CRF1_Bit1 non-inverted

LD9_CRF1h_Bit4.P0; Output "0" to GPIO31 pin (J33_Pin10)

LD7_CRF0h_Bit0.P1; Let GPIO10 as input pin

LD7_CRF2h_Bit0.P0; Let CRF1_Bit0 non-inverted

Read LD7_CRF1h_Bit0; Read the status from GPIO10 pin (J38_Pin1)

How to access W83627DHG CR?

In 2801290, the EFER = 002Eh, and EFDR = 002Fh.

EFER and EFDR are 2 IO ports needed to access W83627DHG CR.

EFER is the Index Port, EFDR is the Data Port.

CR index number needs to be written into EFER first,

Then the data will be read/written from/to EFDR.

To R/W W83627DHG CR, it is needed to Enter/Enable Configuration Mode first. When completing the programming, it is suggested to Exit/Disable Configuration Mode.

Enter Configuration Mode: Write 87h to IO port EFER twice.

Exit Configuration Mode: Write AAh to IO port EFER.

3.6.3 Example

Define GPIO14 as output pin, and output "0" to this pin.

```
mov    dx,4eh    ; Enter Configuration Mode
mov    al,87h
out    dx,al
jmp    $+2
out    dx,al

mov    dx,4eh
mov    al,2ah    ; Read CR2A
out    dx,al
mov    dx,2fh
in     al,dx
or     al,82h    ; Set GPIO multiplexed pins as bit7, bit2 as 1, 1 for
                ; Group 1 as GPIO

mov    ah,al
mov    dx,4eh
mov    al,2ah
out    dx,al
mov    dx,2fh
mov    al,ah
out    dx,al
mov    dx,4eh
mov    al,07h    ; Point to LDN7
out    dx,al
mov    dx,2fh
mov    al,07h
out    dx,al
mov    dx,4eh    ; Read CR30
mov    al,30h
out    dx,al
mov    dx,2fh
in     al,dx
or     al,01h
mov    ah,al
```

```
mov    dx,4eh    ; CR30_Bit0.P1
mov    al,30h
out    dx,al
mov    dx,2fh
mov    al,ah
out    dx,al

mov    dx,4eh
mov    al,0f0h   ; Read  LD7_CRF0
out    dx,al
mov    dx,2fh
in     al,dx
and    al,0efh
mov    ah,al

mov    dx,4eh
mov    al,0f0h   ; LD7_CRF0_Bit4.P0
out    dx,al
mov    dx,2fh
mov    al,ah
out    dx,al

mov    dx,4eh
mov    al,0f2h   ; Read  LD7_CRF2
out    dx,al
mov    dx,2fh
in     al,dx
and    al,0efh
mov    ah,al

mov    dx,4eh
mov    al,0f2h   ; LD7_CRF2_Bit4.P0
out    dx,al
mov    dx,2fh
mov    al,ah
out    dx,al
mov    dx,4eh
mov    al,0f1h   ; Read  LD7_CRF1
out    dx,al
mov    dx,2fh
in     al,dx
and    al,0efh
mov    ah,al
```

```
mov    dx,4eh
mov    al,0f1h    ; LD7_CRF1_Bit4.P0
out    dx,al
mov    dx,2fh
mov    al,ah
out    dx,al

mov    dx,4eh    ; Exit Configuration Mode
mov    al,0AAh
out    dx,al
```

Chapter 4

BIOS Setup Information

2801290 is equipped with the AWARD BIOS stored in Flash ROM. These BIOS has a built-in Setup program that allows users to modify the basic system configuration easily. This type of information is stored in CMOS RAM so that it is retained during power-off periods. When system is turned on, 2801290 communicates with peripheral devices and checks its hardware resources against the configuration information stored in the CMOS memory. If any error is detected, or the CMOS parameters need to be initially defined, the diagnostic program will prompt the user to enter the SETUP program. Some errors are significant enough to abort the start-up.

4.1 Entering Setup

Turn on or reboot the computer. When the message "Hit if you want to run SETUP" appears, press key immediately to enter BIOS setup program.

If the message disappears before you respond, but you still wish to enter Setup, please restart the system to try "COLD START" again by turning it OFF and then ON, or touch the "RESET" button. You may also restart from "WARM START" by pressing <Ctrl>, <Alt>, and <Delete> keys simultaneously. If you don't press the keys at the right time and the system will not boot; an error message will be displayed and you will again be asked to Press <F1> to Run SETUP or Resume.

In HIFLEX BIOS setup, you can use the keyboard to choose among options or modify the system parameters to match the options with your system. The table below will show you all of keystroke functions in BIOS setup.

General Help	
↑↓→←	: Move
Enter	: Select
+ / - /PU /PD	: Value
ESC	: Exit
F1	: General Help
F2	: Item Help
F5	: Previous Values
F6	: Fail-Safe Defaults
F7	: Optimized Defaults
F9	: Menu in BIOS
F10	: Save

4.2 Main Menu

Once you enter 2801290 AWARD BIOS CMOS Setup Utility, you should start with the Main Menu. The Main Menu allows you to select from eleven setup functions and two exit choices. Use arrow keys to switch among items and press <Enter> key to accept or bring up the sub-menu.

Phoenix- AwardBIOS CMOS Setup Utility

<ul style="list-style-type: none"> f Standard CMOS Features f Advanced BIOS Features f Advanced Chipset Features f Integrated Peripherals f Power Management Setup f PnP/PCI Configurations f PC Health Status 	<ul style="list-style-type: none"> f Frequency/Voltage Control Load Fail-Safe Defaults Load Optimized Defaults Set Supervisor Password Set User Password Save & Exit Setup Exit Without Saving
ESC : Quit F9 : Menu in BIOS ↑ ↓ → ← : Select Item F10 : Save & Exit Setup	
Time, Date, Hard Disk Type ...	

Note:

It is strongly recommended to reload Optimal Setting if CMOS is lost or BIOS is updated.

4.3 Standard CMOS Setup Menu

This setup page includes all the items in standard compatible BIOS. Use the arrow keys to highlight the item and then use the <PgUp>/<PgDn> or <+>/<-> keys to select the value or number you want in each item and press <Enter> key to certify it.

Follow command keys in CMOS Setup table to change Date, Time, Drive type, and Boot Sector Virus Protection Status.

Phoenix- AwardBIOS CMOS Setup Utility
Standard CMOS Features

Date (mm:dd:yy)	Thu, Nov 30 2006	Item Help
Time (hh:mm:ss)	10 : 20 : 30	
f IDE Channel 0 Master	[None]	Menu Level f Change the day, month, year and century
f IDE Channel 0 Slave	[None]	
f IDE Channel 1 Master	[None]	
f IDE Channel 1 Slave	[None]	
f IDE Channel 2 Master	[None]	
f IDE Channel 3 Master	[None]	
f IDE Channel 4 Master	[None]	
f IDE Channel 4 Slave	[None]	
Drive A	[1.4M, 3.5 in.]	
Drive B	[None]	
Video	[EVG/VGA]	
Halt On	[All, But Keyboard]	
Base Memory	640K	
Extended Memory	514048K	
Total Memory	515072K	
↑↓→←: Move Enter: Select +/-/PU/PD: Value F10: Save ESC: Exit F1: General Help F5: Previous Values F6: Fail-Safe Defaults F7: Optimized Defaults		

„ Menu Selections

Item	Options	Description
Date	mm:dd:yy	Change the day, month, year and century
Time	hh:mm:ss	Change the internal clock
IDE Channel 0/1/2/3/4 Master	Options are in its sub menu	Press <Enter> to enter the sub menu of detailed options
IDE Channel 0/1/2/4 Slave	Options are in its sub menu	Press <Enter> to enter the next page for detail hard drive settings
Drive A Drive B	None 360K, 5.25 in 1.2M, 5.25 in 720K, 3.5 in 1.44M, 3.5 in 2.88M, 3.5 in	Press <Enter> to enter the next page for detail hard drive settings
Video	EGA/VGA Ĩ CGA 40 CGA 80 MONO	Select the default video device
Halt On	All Errors No Errors All, but Keyboard Ĩ All, but Diskette All, but Disk/Key	Select the situation in which you want the BIOS to stop the POST process and notify you
Base Memory	640K	Displays the amount of conventional memory detected during boot up
Extended Memory	N/A	Displays the amount of extended memory detected during boot up
Total Memory	N/A	Displays the total memory available in the system

4.4 IDE Adaptors Setup Menu

The IDE adaptors control the IDE devices, such as Hard disk drive or CDROM drive. It uses a separate sub menu to configure each hard disk drive.

Phoenix- AwardBIOS CMOS Setup Utility
IDE Channel 0/1/2/3/4 Master

IDE HDD Auto-Detection	[Press Enter]	Item Help
IDE Channel 0 Master Access Mode	[Auto] [Auto]	Menu Level f
<i>Capacity</i>	0 MB	To auto-detect the HDD's size, head ... on this channel
<i>Cylinder</i>	0	
<i>Head</i>	0	
<i>Precomp</i>	0	
<i>Landing Zone</i>	0	
<i>Sector</i>	0	
↑↓→←: Move Enter: Select +/-/PU/PD: Value F10: Save ESC: Exit F1: General Help F5: Previous Values F6: Fail-Safe Defaults F7: Optimized Defaults		

Phoenix- AwardBIOS CMOS Setup Utility
IDE Channel 0/1/4 Slave

IDE HDD Auto-Detection	[Press Enter]	Item Help
IDE Channel 1 Master Access Mode	[Auto] [Auto]	Menu Level f
<i>Capacity</i>	0	To atuo-detect the HDD's size, head ... on this channel
<i>Cylinder</i>	0	
<i>Head</i>	0	
<i>Precomp</i>	0	
<i>Landing Zone</i>	0	
<i>Sector</i>	0	
↑↓→←: Move Enter: Select +/-/PU/PD: Value F10: Save ESC: Exit F1: General Help F5: Previous Values F6: Fail-Safe Defaults F7: Optimized Defaults		

Note:

Oblique items (or data) are based on user's HDD device to display storage configuration.

IDE Channel Menu Selections

Item	Options	Description
IDE HDD Auto-detection	Press Enter	Press Enter to auto-detect the HDD on this channel. If detection is successful, it fills the remaining fields on this menu.
IDE Channel 0/1/2/3/4 Master & 0/1/4 Slave	None Auto Manual	Selecting 'manual' lets you set the remaining fields on this screen. Selects the type of fixed disk. "User Type" will let you select the number of cylinders, heads, etc. Note: PRECOMP=65535 means NONE!
Access Mode	CHS LBA Large Auto	Choose the access mode for this hard disk
Capacity	Auto Display your disk drive size	Disk drive capacity (Approximated). Note that this size is usually slightly greater than the size of a formatted disk given by a disk-checking program.
The following options are selectable only if the 'IDE Channel 0 Master' item is set to 'Manual'		
Cylinder	Min = 0 Max = 65535	Set the number of cylinders for this hard disk.
Head	Min = 0 Max = 255	Set the number of read/write heads
Precomp	Min = 0 Max = 65535	**** Warning: Setting a value of 65535 means no hard disk
Landing zone	Min = 0 Max = 65535	****
Sector	Min = 0 Max = 255	Number of sectors per track

4.5 Advanced BIOS Feature

This section allows you to configure your system for basic operation. You have the opportunity to select the system's default speed, boot-up sequence, keyboard operation, shadowing and security.

Phoenix- AwardBIOS CMOS Setup Utility Advanced BIOS Features

		Item Help
f	CPU Feature	[Press Enter]
f	Hard Disk Boot Priority	[Press Enter]
	Virus Warning	[Disabled]
	CPU L1 & L2 Cache	[Enabled]
	Hyper-Threading Technology	[Enabled]
	Quick Power On Self Test	[Enabled]
	First Boot Device	[Floppy]
	Second Boot Device	[Hard Disk]
	Third Boot Device	[Hard Disk]
	Boot Other Device	[Enabled]
	Swap Floppy Drive	[Disabled]
	Boot up Floppy Seek	[Enabled]
	Boot up NumLock Status	[On]
	Gate A20 Option	[Fast]
	Typematic Rate Setting	[Disabled]
X	Typematic Rate (Chars/Sec)	6
X	Typematic Delay (Msec)	250
	Security Option	[Setup]
X	APIC Mode	Enabled
	MPS Version Control For OS	[1.4]
	OS Select For DRAM > 64MB	[Non-OS2]
	Console Redirection	Disabled
X	Baud Rat	19200
	Agent after boot	Enabled
	Report No FDD For WIN 95	[No]
	Small Logo(EPA) Show	[Disabled]
	ASF support	[Enabled]
	DMI Event Log	[Enabled]
	Clear All DMI Event Log	[No]
	View DMI Event Log	[Enter]
	Mark DMI Event as Read	[Enter]
	Event Log Capacity	Space Available
	Event Log validity	Valid
↑↓→←: Move Enter: Select +/-/PU/PD: Value F10: Save ESC: Exit F1: General Help F5: Previous Values F6: Fail-Safe Defaults F7: Optimized Defaults		

Phoenix- AwardBIOS CMOS Setup Utility
CPU Feature

Limit CPUID MaxVal	[Disabled]	Item Help
C1E Function	[Auto]	
Execute Disabled Bit	[Enabled]	Menu Level f
↑↓→←: Move Enter: Select +/-/PU/PD: Value F10: Save ESC: Exit F1: General Help F5: Previous Values F6: Fail-Safe Defaults F7: Optimized Defaults		

Limit CPUID Maxval

Set Limit CPUID MaxVal to 3, Should Be "Disabled" for WinXP.

Enabled	For OS: Windows NT4.0 Install.
Disabled	For OS: Windows XP Install.

C1E Function

CPU C1E Function Select.

The choice: Auto, Disabled.

Execute Disabled Bit

Replacing older computers with Execute Disable Bit-enabled systems can halt worm attacks, reducing the need for virus related repairs. In addition, Execute Disable Bit may eliminate the need for software patches aimed at buffer overflow attacks. By combining Execute Disable Bit with anti-virus, firewall, spy ware removal, e-mail filtering software, and other network security measures, IT managers can free IT resources for other initiatives.

The choice: Enabled, Disabled.

Phoenix- AwardBIOS CMOS Setup Utility
Hard Disk Boot Priority

<p>1. ch0 M. : Maxtor 91021U2 2. Bootable add-in Cards</p>	<p>Item Help</p> <p>Menu Level f Use <↑> or <↓> to select a device, then press <+> to move it up, or <-> to move it down the list. Press <ESC> to exit this menu.</p>
<p>↑↓→←: Move Enter: Select +/-/PU/PD: Value F10: Save ESC: Exit F1: General Help F5: Previous Values F6: Fail-Safe Defaults F7: Optimized Defaults</p>	

Note:

The oblique word is indicating to appear HDD device message, which user employs.

Hard Disk Boot Priority

Select Hard Disk Boot Device Priority. Use <↑> or <↓> to select a device, then press <+> to move it up, or <-> to move it down the list. Press <ESC> to exit this menu.

Bootable Add-in Cards	Select SCSI Boot
-----------------------	------------------

Virus Warning

Allow you to choose the VIRUS warning feature for IDE Hard Disk boot sector protection. If this function is enabled and someone attempt to write data into this area, BIOS will show a warning message on screen and alarm beep.

Enabled	Activates automatically when the system boots up causing a warning message to appear when anything attempts to access the boot sector or hard disk partition table.
Disabled	No warning message will appear when anything attempts to access the boot sector or hard disk partition table.

CPU L1 Cache/L2 Cache

These two categories speed up memory access. However, it depends on CPU/chipset design.

Enabled	Enable Cache
Disabled	Disable Cache

Hyper-Threading Technology

“Enabled” for Windows XP and Linux 2.4.X (OS optimized for Hyper-Threading Technology and “Disabled” for other OS (OS not optimized for Hyper-Threading Technology).

The choice: Enabled, Disabled.

Quick Power On Self Test

Allows the system to skip certain tests while booting. This will decrease the time needed to boot the system.

Enabled	Enable quick POST
Disabled	Normal POST

First/Second/Third Boot Device

Select your boot device priority.

The choice: Floppy, LS120, Hard Disk, CDROM, ZIP100, USB-FDD, USB-ZIP, USB-CDROM, LAN and Disabled.

Boot Other Device

Select your boot device priority.

The choice: Enabled, Disabled.

Swap Floppy Drive

If the system has two floppy drives, choose enable to assign physical driver B to logical drive A and Vice-Versa.

The choice: Enabled, Disabled.

Boot Up Floppy Seek

Enabled tests floppy drives to determine whether they have 40 or 80 tracks.

The choice: Enabled, Disabled.

Boot Up NumLock Status

Select power on state for NumLock.

The choice: Off, On.

Gate A20 Option

Fast-lets chipsets control Gate A20 and Normal – a pin in the keyboard controller controls Gate A20.

The choice: Normal, Fast.

Typematic Rate Setting

Keystrokes repeat at a rate determined by the keyboard controller – When enabled, the typematic rate and typematic delay can be selected.

The choice: Enabled, Disabled.

Typematic Rate (Chars/sec)

The rate at which character repeats when you hold down a key.

The choice: 6, 8, 10, 12, 15, 20, 24, and 30. (Default 6)

Typematic delay (Msec)

The delay before keystrokes begin to repeat.

The choice: 250, 500, 750, and 1000. (Default 250)

Security Option

Select whether the password is required every time the system boots or only when you enter setup.

System	The system will not boot and access to Setup will be denied if the correct password is not entered at the prompt.
Setup	The system will boot, but access to Setup will be denied if the correct password is not entered at the prompt.

APIC Mode

Setting to Enabled can cause instabilities. Once the operating system is installed, such as Windows XP in my case, this setting cannot be changed without reinstalling the operating system, regardless of whether the initial setting is Disabled or Enabled. The purpose of setting it to Enabled is to extend the number of IRQ's, which sounds like a real risky proposition. I'm not surprised to see the conclusion reached at APIC: Benefit or Trouble. The number of IRQ's should be fine without being extended, anyway.

The choice: Enabled, Disabled. (Default Enabled)

MPS Version Control For OS

Not changeable with APIC Mode set to disabled.

The choice: 1.1, 1.4.

OS Select For DRAM > 64MB

Select OS/2 only if you are running OS/2 operating system with greater than 64MB of RAM on the system.

The choice: Non-OS2, OS2.

Report No FDD for WIN 95

The choice: No, Yes.

Small Logo (EPA) Show

Enabled	The EPA logo will appear during system boot-up.
Disabled	The EPA logo will not appear during system boot-up.

ASF support

The choice: Enabled, Disabled.

DMI Event Log

The choice: Enabled, Disabled.

Clear ALL DMI Event Log

The choice: Yes, No.

View DMI Event Log

Press Enter to show all DMI event log.

Mark DMI Event as Read

Clear all DMI event logs immediately. Press enter will pop up a confirm screen. Hit [Y] and [Enter], then clear all DMI event logs right now.

4.6 Advanced Chipset Feature

This section allows you to configure the system based on the specific features of the Intel 945G chipset. This chipset manages bus speeds and access to system memory resources, such as DRAM (DDR II SDRAM) and the external cache. It also coordinates communications between the conventional PCI Express bus and PCI bus. It must be stated that these items should never need to be altered. The default settings have been chosen because they provide the best operating conditions for your system. The only time you might consider making any changes would be if you discovered that data was being lost while using your system.

Phoenix- AwardBIOS CMOS Setup Utility Advanced Chipset Features

System BIOS Cacheable	[Enabled]	Item Help
Memory Hole At 15M-16M	[Disabled]	
f PCI Express Root Port Func	[Press Enter]	Menu Level f
f Advance Fan Speed Control	[Press Enter]	
AMT BIOS Support	[Enabled]	
GbE LAN	[Enabled]	
SOL Support	Enabled	
IDE-R Support	Enabled	
** VGA Setting **		
PEG/Onchip VGA Control	[Auto]	
On-Chip Frame Buffer Size	[8MB]	
DVMT Mode	[DVMT]	
DVMT /FIXED Memory Size	[128MB]	
↑↓→←: Move Enter: Select +/-/PU/PD: Value F10: Save ESC: Exit F1: General Help F5: Previous Values F6: Fail-Safe Defaults F7: Optimized Defaults		

Note:

Watch Out! If user would like to adopt add-on card such as PCI or PCI-Express graphic card to instead of on board VGA function, please set "PEG/Onchip VGA Control" default to [PEG Port].

System BIOS Cacheable

Selecting Enabled allows caching of the system BIOS ROM at F0000h-FFFFFh, resulting in better system performance. However, if any program writes to this memory area, a system error may result.

The choice: Enabled, Disabled.

Memory Hole At 15-16M

In order to improve performance, certain space in memory is reserved for ISA cards. This memory must be mapped into the memory space below 16MB.

The choice: Enabled, Disabled.

PCI Express Root Port Fnction

Phoenix- AwardBIOS CMOS Setup Utility
 PCI Express Root Port Func

PCI Express Port 1	[Enabled]	Item Help
PCI Express Port 2	[Enabled]	Menu Level f
PCI Express Port 3	[Enabled]	
PCI Express Port 4	[Enabled]	
PCI Express Port 5	[Enabled]	
PCI Express Port 6	[Enabled]	
PCI-E Compliancy Mode	[v1.0a]	
↑↓→←: Move Enter: Select +/-/PU/PD: Value F10: Save ESC: Exit F1: General Help F5: Previous Values F6: Fail-Safe Defaults F7: Optimized Defaults		

The choice: Auto, Enabled, Disabled.

Advanced Fan Speed Control

Phoenix- AwardBIOS CMOS Setup Utility
 Advance Fan Speed Control

Fan1 Speed Monitor	[Enabled]	Item Help
Fan2 Speed Monitor	[Enabled]	Menu Level f
↑↓→←: Move Enter: Select +/-/PU/PD: Value F10: Save ESC: Exit F1: General Help F5: Previous Values F6: Fail-Safe Defaults F7: Optimized Defaults		

The choice: Enabled, Disabled.

AMT BIOS Support

The choice: Disabled, Enabled.

GbE LAN

The choice: Disabled, Enabled.

PEG/Onchip VGA Control

The choice: On chip VGA, PEG Port, and Auto.

On-Chip Frame Buffer Size

The Choice: 1MB, 8MB.

DVMT Mode

The choice: FIXED. DVMT.

DVME/FIXED Memory Size

Adjusting graphic memory size of system share memory.

The choice: 128MB, 256MB, MAX.

4.7 Integrated Peripherals

Phoenix- AwardBIOS CMOS Setup Utility
Integrated Peripherals

f OnChip IDE Device [Press Enter]	Item Help
CPU Relative Temperature Current FAN1 Speed Current FAN2 Speed Current FAN3 Speed	Menu Level f
f Super IO Device [Press Enter]	
Watch Dog Timer Select [Disabled]	
f USB Device Setting [Press Enter]	
↑↓→←: Move Enter: Select +/-/PU/PD: Value F10: Save ESC: Exit F1: General Help F5: Previous Values F6: Fail-Safe Defaults F7: Optimized Defaults	

Phoenix- AwardBIOS CMOS Setup Utility
OnChip IDE Device

IDE HDD Block Mode	[Enabled]	<p>Item Help</p> <hr/> <p>Menu Level f</p> <p>If your IDE hard drive supports block mode select Enabled for automatic detection of the optimal number of block read/writes per sector the drive can support.</p>
IDE DMA transfer access	[Enabled]	
IDE Primary Master PIO	[Auto]	
IDE Primary Slave PIO	[Auto]	
IDE Primary Master UDMA	[Auto]	
IDE Primary Slave UDMA	[Auto]	
On-Chip Secondary PCI IDE	[Enabled]	
IDE Secondary Master PIO	[Auto]	
IDE Secondary Slave PIO	[Auto]	
IDE Secondary Master UDMA	[Auto]	
IDE Secondary Slave UDMA	[Auto]	
SATA Mode	[IDE]	
<p>↑↓→←: Move Enter: Select +/-/PU/PD: Value F10: Save ESC: Exit F1: General Help</p> <p>F5: Previous Values F6: Fail-Safe Defaults F7: Optimized Defaults</p>		

IDE HDD Block Mode

If your IDE hard drive supports block mode select Enabled for automatic detection of the optimal number of block read/writes per sector the drive can support.

The choice: Enabled, Disabled.

IDE DMA transfer access

The choice: Enabled, Disabled.

IDE Primary/Secondary Master/Slave PIO

The four IDE PIO (Programmed Input/Output) fields let you set a PIO mode (0-4) for each of the four IDE devices that the onboard IDE interface supports. Modes 0 through 4 provide successively increased performance. In Auto mode, the system automatically determines the best mode for each device.

The choice: Auto, Mode 0, Mode 1, Mode 2, Mode 3, and Mode 4.

IDE Primary/Secondary Master/Slave UDMA

Ultra DMA/33/66/100 implementation is possible only if your IDE hard drive supports it and the operating environment includes a DMA driver (Windows 95 OSR2 or a third-party IDE bus master driver). If your hard drive and your system software both support Ultra DMA/33/66/100, select Auto to enable BIOS support.

The choice: Auto, Disabled.

On-Chip Secondary PCI IDE

The chipset contains a PCI IDE interface with support for two IDE channels. Select Enabled to activate the primary IDE interface. Select Disabled to deactivate this interface.

The choice: Enabled, Disabled.

SATA Mode

IDE	Use the Serial ATA hard disk drives as Parallel ATA physical Storage devices.
RAID	With Intel Matrix Storage Technology with RAID 0, 1, 5, 10 support.
AHCI	The Advanced Host Controller Interface (AHCI) specification describes the register-level interface for a Host Controller for Serial ATA 1.0a and Serial ATA II.

Phoenix- AwardBIOS CMOS Setup Utility
Super IO Device

Onboard FDC Controller	[Enabled]	Item Help
Onboard Serial Port 1	[3F8/IRQ4]	
Onboard Serial Port 2	[2F8/IRQ3]	Menu Level f
UART Mode Select	[Normal]	
<i>X RxD, TxD Active</i>	<i>Hi, Lo</i>	
<i>X IR Transmission Delay</i>	<i>Enabled</i>	
<i>X UR2 Duplex Mode</i>	<i>Half</i>	
<i>X Use IR Pins</i>	<i>IR-Rx2Tx2</i>	
Onboard Parallel Port	[378/IRQ7]	
Parallel Port Mode	[SPP]	
<i>X EPP Mode Select</i>	<i>EPP1.7</i>	
<i>X ECP Mode Use DMA</i>	<i>3</i>	
PWRON After PWR-Fail	[Off]	
Onboard Serial Port 3	[3E8]	
Serial Port 3 Use IRQ	[IRQ10]	
Onboard Serial Port 4	[2E8]	
Serial Port 4 Use IRQ	[IRQ11]	
↑↓→←: Move Enter: Select +/-/PU/PD: Value F10: Save ESC: Exit F1: General Help F5: Previous Values F6: Fail-Safe Defaults F7: Optimized Defaults		

Onboard FDC Controller

This item allows you to enable/disable onboard Floppy disk controller.

The choice: Enabled, Disabled.

Onboard Serial Port 1/Port 2

Select an address and corresponding interrupt for the first and second serial ports.

The choice: Disabled, 3F8/IRQ4, 2F8/IRQ3, 3E8/IRQ4, 2E8/IRQ3, Auto.

UART Mode Select

This item allows users to select Infrared transmission mode.

Normal	Disable Infrared function
IrDA	Select IrDA mode transmission
ASKIR	Select ASKIR mode transmission

Watch out! Below 4 kinds of selectable item are based on UARM Mode select setting

RxD, TxD Active

This item is to configure Infrared transmission rate. Four options are available:

Hi, Hi	High rate for receiving / High rate for transmitting
Hi, Lo	High rate for receiving / Low rate for transmitting
Lo, Hi	Low rate for receiving / High rate for transmitting
Lo, Lo	Low rate for receiving / Low rate for transmitting

IR Transmission Delay

This option will be available when IR is enabled.

The choice: Enabled, Disabled.

UR2 Duplex Mode

The available choices are full duplex mode and half duplex mode

The choice: Full, Half.

Use IR Pins

The available choices are IR-Rx2Tx2/ RxD2, TxD2.

The choice: IR-Rx2Tx2 / RxD2, TxD2.

Onboard Parallel Port

This item allows you to configure I/O address of the onboard parallel port.

The choice: Disabled, 378/IRQ7, 278/IRQ5, and 3BC/IRQ7.

Parallel Port Mode

There are four different modes for the onboard parallel port:

SPP	Switch to SPP mode
EPP	Switch to EPP mode
ECP	Switch to ECP mode
ECP + EPP	Switch to ECP + EPP mode
Normal	Switch to Normal mode

Watch out! Below 2 kinds of selectable item are based on UARM Mode select setting

EPP Mode Select

Select different version of EPP mode.

The choice: EPP1.7, EPP1.9.

ECP Mode Use DMA

Select a proper DMA channel for ECP mode.

The choice: 1, 3.

PWERON Afer PWR-Fail

The choice: Off, On.

On Board Serial Port 3

The choice: Disabled, 3F8, 2F8, 3E8, 2E8.

Serial Port 3 Use IRQ

The choice: IRQ10, IRQ11, IRQ3, IRQ4.

On Board Serial Port 4

The choice: Disabled, 3F8, 2F8, 3E8, 2E8.

Serial Port 4 Use IRQ

The choice: IRQ10, IRQ11, IRQ3, IRQ4.

Phoenix- AwardBIOS CMOS Setup Utility
Onboard Device

USB 1.0 Controller	[Enabled]	Item Help
USB 2.0 Controller	[Enabled]	
USB Operation Mode	[High Speed]	Menu Level f
USB Keyboard Function	[Enabled] USB	
Mouse Function	[Enabled]	
USB Storage Function	[Enabled]	
*** USB Mass Storage Device Boot Setting ***		
↑↓→←: Move Enter: Select +/-/PU/PD: Value F10: Save ESC: Exit F1: General Help F5: Previous Values F6: Fail-Safe Defaults F7: Optimized Defaults		

USB 1.0/2.0 Controller

This entry is for disable/enable EHCI controller only. This BIOS itself may/may not have high speed USB support built in, the support will be automatically turn on when high speed device were attached.

The choice: Enabled, Disabled.

USB Operation Mode

Auto decide USB device operation mode. [High speed]: if USB device was high speed device, then it operated

USB Keyboard Support

This item allows you to enable USB keyboard function under POST, BIOS setup menu, DOS, or Windows-NT with no USB driver loaded.

The choice: Enabled, Disabled.

USB Mouse Support

This item allows you to enabled USB Mouse function under POST, BIOS Setup menu, DOS, or Window-NT with no USB driver loaded.

The choice: Enabled, Disabled.

USB Storage Function

[Enabled] or [Disabled] legacy support of USB Mass storage.

The choice: Enabled, Disabled.

Watch Dog Timer Select

This BIOS testing option is able to reset the system according to the selected table.

The choice: Disabled, 10 Sec, 20 Sec, 30 Sec, 40 Sec, 1 Min, 2 Min, and 4 Min.

4.8 Power Management Setup

The Power Management Setup allows you to configure your system to most effectively save energy while operating in a manner consistent with your own style of computer use.

Phoenix- AwardBIOS CMOS Setup Utility
Power Management Setup

<p>ACPI Function [Enabled]</p> <p>ACPI Suspend Type [S3(POS)]</p> <p>Run VGABIOS if S3 Resume [Auto]</p> <p>Power Management [User Define]</p> <p>Video Off Method [DPMS] Video</p> <p>Off In Suspend [Yes] Suspend</p> <p>Type [Stop Grant]</p> <p>MODEM Use IRQ [3]</p> <p>Suspend Mode [Disabled]</p> <p>HDD Power Down [Disabled]</p> <p>Soft-Off by PWR-BTTN [Instant-Off]</p> <p>Wake-up by On Board LAN [Enabled]</p> <p>Power On by Ring [Enabled]</p> <p>USB KB Wake-Up From S3 [Disabled]</p> <p>Resume by Alarm [Disabled]</p> <p>X Date(of Month) Alarm 0</p> <p>X Time(hh:mm:ss) Alarm 0 : 0 :0</p> <p style="text-align: center;">** Reload Global Timer Events **</p> <p>Primary IDE 0 [Disabled]</p> <p>Primary IDE 1 [Disabled]</p> <p>Secondary IDE 0 [Disabled]</p> <p>Secondary IDE 1 [Disabled]</p> <p>FDD,COM,LPT Port [Disabled]</p> <p>PCI PIRQ[A-D]# [Disabled]</p>	<p style="text-align: center;">Item Help</p> <hr/> <p>Menu Level f</p>
<p>↑↓→←: Move Enter: Select +/-/PU/PD: Value F10: Save ESC: Exit F1: General Help</p> <p style="text-align: center;">F5: Previous Values F6: Fail-Safe Defaults F7: Optimized Defaults</p>	

ACPI Function

This item allows you to enable/disable the Advanced Configuration and Power Management.

The choice: Enabled, Disabled.

ACPI Suspend Type

To decide which ACPI suspend mode to use.

The choice: S1(POS), S3(STR).

Run VGA BIOS if S3 Resume

The choice: Auto, Yes, No.

Power Management

This category allows you to select the type (or degree) of power saving and is directly related to "HDD Power Down", "Suspend Mode".

There are three selections for Power Management, three of which have fixed mode settings.

Min. Power Saving	Minimum power management. Suspend Mode = 1 Hour, and HDD Power Down = 15 Min.
Max. Power Saving	Maximum power management. Suspend Mode = 1 Min., and HDD Power Down = 1 Min.
User Defined	Allow you to set each mode individually. When not disabled, Suspend Mode ranges from 1 min. to 1 Hour and HDD Power Down ranges from 1 Min. to 15 Min.

Video Off Method

This determines the manner in which the monitor is blanked.

V/H SYNC+Blank	This selection will cause the system to turn off the vertical and horizontal synchronization ports and write blanks to the video buffer.
Blank Screen	This option only writes blanks to the video buffer.
DPMS	Initial display power management signaling.

Video Off In Suspend

This allows user to enable/disable video off in Suspend Mode.

The choice: Yes, No.

Suspend Type

Two options are available: Stop Grant and PwrOn Suspend.

The choice: Stop Grant, PwrOn Suspend.

MODEM Use IRQ

The choice: NA, 3, 4, 5, 7, 9, 10, 11.

Suspend Mode

When enabled and after the set time of system inactivity, all devices except the CPU will be shut off.

The choice: Disabled, 1 Min, 2 Min, 4 Min, 8 Min, 12 Min, 20 Min, 30 Min, 40 Min, and 1 Hour.

HDD Power Down

When enabled and after the set time of system inactivity, the hard disk drive will be powered down while all other devices remain active.

The choice: Disabled, 1 Min, 2 Min, 3 Min, 4 Min, 5 Min, 6 Min, 7 Min, 8 Min, 9 Min, 10 Min, 11 Min, 12 Min, 13 Min, 14 Min, 15 Min.

Soft-Off by PWR-BTTN

This item allows users to set the time to remove the power after the power button is pressed.

The choice: Instant-Off, Delay 4 Sec.

PWRON After PWR-Fail

This item allows user to configure the power status of using ATX power supply after a serious power loss occurs.

On	System automatically restores power back
Off	System stays at power -off

Wake-Up by On Board LAN

This option can be enabled to support Wake Up by on-board LAN.

The choice: Disabled, Enabled.

Power On by Ring

When select "Enabled", a system that is at soft-off mode will be alert to Wake-On-Modem signal.

The choice: Enabled, Disabled.

USB KB Wake-up From S3

The choice: Enabled, Disabled.

Resume by Alarm

This item allows users to enable/disable the resume by alarm function. When "Enabled" is selected, system using ATX power supply could be powered on if a customized time and day is approached.

The choice: Enabled, Disabled.

Date(of Month) Alarm

When "Resume by Alarm" is enabled, this item could allow users to configure the date parameter of the timing dateline on which to power on the system.

The choice: 0 ~ 31.

Time(hh:mm:ss) Alarm

When "Resume by Alarm" is enabled, this item could allow users to configure the time parameter of the timing dateline on which to power on the system.

The choice: hh (0~23), mm (0~59), ss (0 ~59).

Primary/Secondary IDE 0/1

This item is to configure IDE devices being monitored by system so as to keep system out of suspend mode if the associated device is busy.

The choice: Enabled, Disabled.

FDD, COM, LPT Port

This item is to configure floppy device, COM ports, and parallel port being monitored by system so as to keep system out of suspend mode if the associated device is busy.

The choice: Enabled, Disabled.

PCI PIRO[A-D]#

This option can be used to detect PCI device activities. If they are activities, the system will go into sleep mode.

The choice: Enabled, Disabled.

4.9 PnP/PCI Configurations

This section describes configuring the PCI bus system. PCI, or Personal Computer Interconnect, is a system, which allows I/O devices to operate at speeds nearing the speed the CPU itself, uses when communicating with its own special components.

This section covers some very technical items and it is strongly recommended that only experienced users should make any changes to the default settings.

Phoenix- AwardBIOS CMOS Setup Utility PnP/PCI Configurations

Init Display First	[PCI Slot]	Item Help
Reset Configuration Data	[Disabled]	
Resources Controlled By	[Auto(ESCD)]	Menu Level f
X IRQ Resources	Press Enter	
PCI/VGA Palette Snoop	[Disabled]	
*** PCI Express relative item ***		
Maximum Payload Size	[128]	
↑↓→←: Move Enter: Select +/-/PU/PD: Value F10: Save ESC: Exit F1: General Help F5: Previous Values F6: Fail-Safe Defaults F7: Optimized Defaults		

Init Display First

This item allows you to select the first display port to be initialized.

The choice: PCI Slot, Onboard.

Reset Configuration Data

Default is disabled. Select Enabled to reset Extended System Configuration Data (ESCD) when you exit Setup if you have installed a new add-on and the system reconfiguration has caused such a serious conflict that the OS cannot boot.

The choice: Enabled, Disabled.

Resource Controlled By

BIOS can automatically configure the entire boot and plug and play compatible devices. If you choose Auto, you cannot select IRQ DMA and memory base address fields, since BIOS automatically assigns them.

The choice: Auto (ESCD), Manual.

Watch Out! Below selection item is based on "Resource Controlled BY" to setting.

IRQ Resources

When resources are controlled manually, assign each system interrupt a type, depending on the type of device using the interrupt.

Enter for more options IRQ-3/IRQ-4/IRQ-5/IRQ-7/IRQ-9/IRQ-10/IRQ-11/IRQ-12/IRQ-14/IRQ-15 assigned to. The choice: PCI Device / Reserved.

PCI/VGA Palette Snoop

Leave this field at "Disabled".

The choice: Enabled, Disabled.

Maximum Payload Size

Default: 128

4.10 PC Health Status

Phoenix- AwardBIOS CMOS Setup Utility
PC Health Status

<p>CPU Warning Temperature [Disabled]</p> <p><i>Back System1 Temperature</i></p> <p><i>CPU Temperature</i></p> <p><i>Front System Temperature</i></p> <p><i>J45 Fan Speed</i> 0RPM</p> <p><i>J44 Fan (CPU Fan) Speed</i> 0RPM</p> <p><i>J46 Fan Speed</i> 0RPM</p> <p><i>J50 Fan Speed</i> 0RPM</p> <p><i>J51 Fan Speed</i> 0RPM</p> <p><i>Vcore</i> 1.24 V</p> <p><i>+12 V</i> 12.03 V</p> <p><i>-12 V</i> 12.36 V</p> <p><i>Vcc (V)</i> 5.61 V</p> <p><i>+ 5 V</i> 5.07 V</p> <p><i>VBAT(V)</i> 3.26 V</p> <p><i>5VSB(V)</i> 5.07 V</p> <p><i>+1.25V GMCH Vcore</i> 1.26 V</p> <p><i>+1.8V DDR</i> 1.80 V</p> <p><i>3V_DUAL</i> 3.37 V</p> <p>Smart CPU Fan2 Temperature [40 /88]</p> <p>Fan2 Tolerance Value [5]</p>	<p style="text-align: center;">Item Help</p> <hr/> <p>Menu Level f</p>
<p>↑↓→←: Move Enter: Select +/-/PU/PD: Value F10: Save ESC: Exit F1: General Help</p> <p>F5: Previous Values F6: Fail-Safe Defaults F7: Optimized Defaults</p>	

Note:

Upon oblique items (or data) will be based on device and power source variation.

CPU Warning Temperature

This item allows you to set a temperature above which the system will start the beeping warning. Default setting is disabled. This function will only with "ACPI" power management and "S3 (STR)" suspends type.

The choices : Disabled, 50°C /122°F, 53°C /127°F, 56°C /133°F, 60°C /140°F, 63°C /145°F, 66°C /151°F, 70°C /158°F.

Smart Fan2 Temperature.

The choices : Disabled, 30°C / 86°F, 35°C / 95°F, 40°C /104°F.

Fan2 Tolerance Value

Min= 1, Max= 5; Key in a DEC number:

4.11 Frequency/Voltage Control

Phoenix- AwardBIOS CMOS Setup Utility
PC Health Status

Auto Detect PCI Clk	[Enabled]	Item Help
Spread Spectrum	[Disabled]	
CPU Host/SRC/PCI Clock	[Default]	Menu Level f
↑↓→←: Move Enter: Select +/-/PU/PD: Value F10: Save ESC: Exit F1: General Help F5: Previous Values F6: Fail-Safe Defaults F7: Optimized Defaults		

Auto Detect PCI Clk

The Choice: Disabled, Enabled.

Spread Spectrum

The choice: Enabled, Disabled.

CPU Host/SRC/PCI Clock

The choice: Default, 100/100/33MHZ, 133/100/33MHZ, 166/100/33MHZ, 200/100/33MHZ, 266/100/33MHZ, 333/100/33MHZ.

4.12 Default Menu

Selecting "Defaults" from the main menu shows you two options, which are described below

Load Fail-Safe Defaults

When you press <Enter> on this item you get a confirmation dialog box with a message similar to:

Load Fail-Safe Defaults (Y/N)?

Pressing 'Y' loads the BIOS default values for the most stable, minimal-performance system operations.

Load Optimized Defaults

When you press <Enter> on this item you get a confirmation dialog box with a message similar to:

Load Optimized Defaults (Y/N) ? **N**

Pressing 'Y' loads the default values that are factory settings for optimal performance system operations.

4.13 Supervisor/User Password Setting

You can set either supervisor or user password, or both of them. The differences between are:

Set Supervisor Password: can enter and change the options of the setup menus.

Set User Password: just can only enter but do not have the right to change the options of the setup menus. When you select this function, the following message will appear at the center of the screen to assist you in creating a password.

ENTER PASSWORD

Type the password, up to eight characters in length, and press <Enter>. The password typed now will clear any previously entered password from CMOS memory. You will be asked to confirm the password. Type the password again and press <Enter>. You may also press <Esc> to abort the selection and not enter a password.

To disable a password, just press <Enter> when you are prompted to enter the password. A message will confirm the password will be disabled. Once the password is disabled, the system will boot and you can enter Setup freely.

PASSWORD DISABLED

When a password has been enabled, you will be prompted to enter it every time you try to enter Setup. This prevents an unauthorized person from changing any part of your system configuration.

Additionally, when a password is enabled, you can also require the BIOS to request a password every time your system is rebooted. This would prevent unauthorized use of your computer.

4.14 Exiting Selection

Save & Exit Setup

Pressing <Enter> on this item asks for confirmation:

Save to CMOS and EXIT (Y/N)? **Y**

Pressing “Y” stores the selections made in the menus in CMOS – a special section of memory that stays on after you turn your system off. The next time you boot your computer, the BIOS configures your system according to the Setup selections stored in CMOS. After saving the values the system is restarted again.

Exit Without Saving

Pressing <Enter> on this item asks for confirmation:

Quit Without Saving (Y/N)? **N**

This allows you to exit Setup without storing in CMOS any change. The previous selections remain in effect. This exits the Setup utility and restarts your computer.

Chapter 5

Troubleshooting

This chapter provides a few useful tips to quickly get 2801290 running with success. As basic hardware installation has been addressed in Chapter 2, this chapter will primarily focus on system integration issues, in terms of BIOS setting, and OS diagnostics.

5.1 Hardware Quick Installation

CPU Installation

Due to the design of 2801290, it only supports Intel® Core 2 Duo, Pentium® D, Pentium® 4, Celeron® D processor. Before installing CPU, please ensure the processor chosen is the right one. Regarding to CPU information, please refer to Intel website; <http://www.intel.com>

P4 Power connector

+12V CPU Supplementary Power connector is required on 2801290. It is because Global American, Inc. wants to provide the customer with better performance and more reliable systems. By using this CPU Supplementary will enhance the power drawing to the motherboard. However, J41, +12V CPU Supplementary Power connector must be connected all the time. Otherwise, the system will fail to boot up.

ATX Power Setting

2801290 supports ATX only; However, there are only two connectors that must be connected—J40 (20 pins Power Connector) and J41.

Serial ATA Hardware and SATA RAID Installation

Unlike IDE bus, each Serial ATA channel can only connect to single SATA hard disk at simultaneously; there are five SATA connectors on motherboard, J11, J12, J13, J14, J15. The installation of Serial ATA is simpler and easier than IDE, because SATA hard disk doesn't require setting up Master and Slave, which can reduce mistake of hardware installation. All you need to do is to plug in two cables on SATA HDD (power and data-cable).

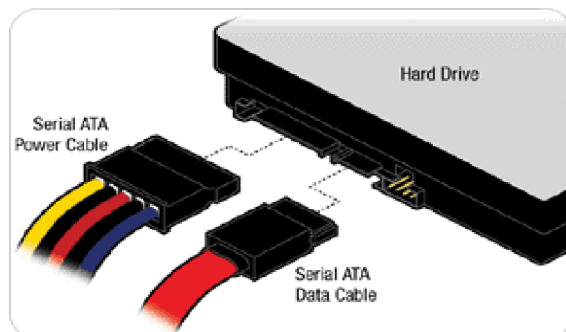

Besides, 2801290 also supports RAID 0, 1, 5, (0+1) functions. To enable SATA RAID function, "SATA Mode" must be set to "RAID Mode". After that, SATA Mode option will be unmasked automatically, and then save default and reboot system.

5.2 Frequency Asking Questions (FAQ)

Q: I have one IDE hard disk and one SATA hard disk. How can I assign SATA Hard disk as First boot device?

A: User just only adjusts the jump of IDE HDD to set at Master device; SATA HDD will be automatically detected. Eventually, please refer 4.5 "Advanced BIOS Features", and then enter "Hard Disk Boot Priority" to set HDD device priority.

Q: When I adopt CF card storage on 2801290, why the system operation is unavailable?

A: An abnormal status, please don't adopt IDE HDD simultaneously, because IDE HDD and CF which are the same channel to be use, that will occur conflict situation.

Q: Since 2801290 has two Giga LAN onboard, could 2801290 support Intel fault tolerance function, or what people called teaming function?

A: Yes, 2801290 fully supports teaming function without any required change. What has to be done is to install Intel PRO drivers we provided in the Global American, Inc. Driver CD, and then go to device manager to enable teaming function. However, for further information, please feel free to contact us so we can send teaming function guideline to you.

Q: I am using an ATA-66 (or 100) hard drive, how can I know that ATA-66 function is enabled?

A: You need to use the 80-pin ATA-66 IDE flat cable to have this function. During the Post phase, you can see ATA-66 (or 100) message while hard drive is being detected. Besides, after installing Microsoft series OS successfully, you also need to Install ATA-66/100 driver to active ATA-66/100 function.

Q: Does 2801290 support boot from LAN function? If it does, how and where can I enable it?

A: 2801290 can support "boot from LAN" function to enable it, please change the setting in "Onboard LAN BOOT ROM Init" in Integrated Peripherals of BIOS. Watch out! Just only connects primary LAN (J22, 82566DM controller) to trigger "boot form LAN" function.

Q: Is it possible to insert PCI-Express X 8, X4, or X1 card on PCI-Express x 16?

A: Yes, you can, but Intel only defines PCI-Express X 16 slot can only configure as PCI-Express x 16 and x 1 card. You may find some other x 8 and x 4 can work on PCI-Express X 16 slot, but there is no guarantee that all the cards will work. If you really need project requirement to use x 4 and x 8 card that currently fail to work on our motherboard, you may contact us to get the help.

Q: After installing PCI Card, why isn't it working?

A: As a matter of fact, some PCI cards will occupy shadow memory, which might cause SBC or PCI malfunction. However, the best way to see if the problem relates to shadow memory or not, please kindly disable USB controller and on board LAN to release more shadow memory space.

To solve this problem, you might also check our download center if there is BIOS for this issue.

<http://www.globalamericaninc.com>

if you cannot find a BIOS or the BIOS on our website cannot solve your problem, please kindly contact Global American, Inc. Technical Support department for solving issue.

5.3 BIOS Setting

It is assumed that users have correctly adopted modules and connected all the devices cables required before turning on ATX power. CPU, CPU Fan, 240-pin DDR2 SDRAM, keyboard, mouse, floppy drive, IDE CD-ROM, SATA hard disk, printer, VGA connector, device cables, ATX accessories or 12V 4-pin power cable are good examples that deserve attention. With no assurance of properly and correctly accommodating these modules and devices, it is very possible to encounter system failures that result in malfunction of any device.

To make sure that you have a successful start with 2801290, it is strongly recommended, when going with the boot-up sequence, to hit "DEL" key and enter the BIOS setup menu to tune up a stable BIOS configuration so that you can wake up your system far well.

Loading the default optimal setting

When prompted with the main setup menu, please scroll down to "Load Optimal Defaults", press "Enter" and "Y" to load in default optimal BIOS setup. This will force your BIOS setting back to the initial factory configuration. It is recommended to do this so you can be sure the system is running with the BIOS setting that Global American, Inc. has highly endorsed. As a matter of fact, users can load the default BIOS setting any time when system appears to be unstable in boot up sequence.

Auto Detect Hard Disks

In the BIOS => Standard CMOS setup menu, pick up any one from Primary/Secondary Master/Slave IDE ports, and press "Enter". Setup the selected IDE port and its access mode to "Auto". This will force system to automatically pick up the IDE devices that are being connected each time system boots up.

Improper disable operation

There are too many occasions where users disable a certain device/feature in one application through BIOS setting. These variables may not be set back to the original values when needed. These devices/features will certainly fail to be detected.

When the above conditions happen, it is strongly recommended to check the BIOS settings. Make sure certain items are set as they should be. These include the floppy drive, COM1/COM2 ports, Parallel port, USB ports, external cache, on-board VGA and Ethernet.

It is also very common that users would like to disable a certain device/port to release IRQ resource. A few good examples are

- Disable COM1 serial port to release IRQ #4
- Disable COM2 serial port to release IRQ #3
- Disable Parallel port to release IRQ #7
- Disable PS/2 mouse to release IRQ #12,
- Etc...

A quick review of the basic IRQ mapping is given below for your reference.

IRQ#	Description
IRQ #0	System Timer
IRQ #1	Keyboard Event
IRQ #2	Usable IRQ
IRQ #3	COM 2
IRQ #4	COM 1
IRQ # 5	Usable IRQ
IRQ #6	Diskette Event
IRQ #7	Usable IRQ
IRQ #8	Real-Time Clock
IRQ #9	Usable IRQ
IRQ #10	Usable IRQ
IRQ #11	Usable IRQ
IRQ #12	IBM Mouse Event
IRQ #13	Coprocessor Error
IRQ #14	Hard Disk Event
IRQ #15	Usable IRQ

It is then very easy to find out which IRQ resource is ready for additional peripherals. If IRQ resource is not enough, please disable some devices listed above to release further IRQ numbers.

System Memory Address Map

Each On-board device in the system is assigned a set of memory addresses, which also can be identical of the device. The following table lists the system memory address used.

0000 – 003F	1K	Interrupt Area
0040 – 004F	0.3K	BIOS Data Area
0050 – 006F	0.5K	System Data
0070 – 0BE3	45K	DOS
0BE4 – 0E1B	8.9K	Program Area
0E1C – 9D66	573K	[Available]
9D67 – 9EFF	6.4K	Program Area
= Conventional memory ends at 636K =		
9F00 – 9FBF	3K	Extended BIOS Area
9FC0 – 9FFF	1K	Unused
A000 – AFFF	64K	VGA Graphics
B000 – B7FF	32K	Unused
B800 – BFFF	32K	VGA Text
C000 – CAFF	44K	Video RAM
CB00 – EEFF	144K	Unused
EF00 – EFFF	4K	ROM
F000 – FFFF	64K	System ROM

Interrupt Request Lines (IRQ)

Peripheral devices can use interrupt request lines to notify CPU for the service required. The following table shows the IRQ used by the devices on board.

IRQ 0	SMARTDRV	System Timer
IRQ 1	SMARTDRV	Keyboard Event
IRQ 2	[Unassigned]	Usable IRQ
IRQ 3	System ROM	COM 2
IRQ 4	System ROM	COM 1
IRQ 5	[Unassigned]	Usable IRQ
IRQ 6	System ROM	Diskette Event
IRQ 7	[Unassigned]	Usable IRQ
IRQ 8	System ROM	Real-Time Clock
IRQ 9	[Unassigned]	Usable IRQ
IRQ 10	[Unassigned]	Usable IRQ
IRQ 11	[Unassigned]	Usable IRQ
IRQ 12	System ROM	IBM Mouse Event
IRQ 13	System ROM	Coprocessor Error
IRQ 14	System ROM	Hard Disk Event
IRQ 15	[Unassigned]	Usable IRQ

Any advice or comments about our products and service, or anything we can help you with please don't hesitate to contact with us. We will do our best to support you for your products, projects and business.

Global American Inc.

Address: 17 Hampshire Drive
Hudson, NH 03051

TEL: Toll Free (U.S. Only) 800-833-8999
(603)886-3900

FAX: (603)886-4545

Website: <http://www.globalamericaninc.com>

E-Mail: salesinfo@globalamericaninc.com

