



User's Manual

2801460 and 2801580

Acknowledgments

Award is a registered trademark of Award Software International, Inc.

PS/2 is a trademark of International Business Machines Corporation.

Intel and Pentium 4 are registered trademarks of Intel Corporation.

Microsoft Windows is a registered trademark of Microsoft Corporation.

Winbond is a registered trademark of Winbond Electronics Corporation.

All other product names or trademarks are properties of their respective owners.

Table of Contents

Introduction	1
Product Description	1
Checklist	2
Specifications.....	3
Board Dimensions.....	4
Installations	5
Installing the CPU	6
Installing the Memory	7
Setting the Jumpers	8
Connectors on 2801460.....	13
Watchdog Timer Configuration.....	22
Digital I/O Sample Code	26
BIOS Setup.....	30
Drivers Installation	52
Intel Chipset Software Installation Utility	53
Intel 845GV Chipset Graphics Driver Installation.....	56
AC97 Codec Audio Driver Installation.....	59
Realtek RTL8139 LAN Drivers Installation	61
Appendix	64
A. I/O Port Address Map.....	64
B. Interrupt Request Lines (IRQ)	65

This page is intentionally left blank.

Introduction

Product Description

The 2801460 Pentium 4 Mini ITX board incorporates the Intel® advanced 845GV Chipset Memory Controller hub and supports 478-pin Intel Pentium 4 processors of 1.3GHz and up to 3.06GHz+ with FSB 533MHz/400MHz. 2801460 supports the Pentium 4 processor with 256-KB L2 cache, Pentium 4 processor with 512-KB L2 cache on 0.13 micron process and Pentium 4 Mobile processor*.

The I/O functions are on 2801460 integrated onto the ICH4. It supports the integrated graphics device (IGD) on the GMCH. The IGD has 3D, 2D, and video capabilities. The system memory size can be up to 1GB, using the single DDR socket on board. Four USB ports are supported with the USB 1.1/2.0 standard.

2801460 supports TV out or LVDS with the use of the Chrontel CH7017 display controller device that accepts two digital graphics input data streams. One data stream outputs through an LVDS transmitter to an LCD panel, while the other data stream is encoded for NTSC or PAL TV and outputs through a 10-bit high speed DAC. The TV encoder device encodes a graphics signal up to 1024x768 resolution and outputs the video signals according to NTSC or PAL standards. The LVDS transmitter operates at pixel speeds up to 165MHz per link, supporting 1600x1200 panels at 60Hz refresh rate. 2801460, however, supports either TV out or LVDS interface one at a time.

The 2801460 Mini ITX SBC supports CRT VGA interface as well as TV out or LVDS interface. Realtek LAN 8100BL supports Ethernet functionality (10/100Mb). The board also has AC97 6CH audio, 4 COM ports, UDMA 100, 4 USB ports, watchdog timer and a PCI slot for expandability. Dimensions of the board are 170mm x 170mm.

This board represents the perfect choice for those who want superior performance for POS, kiosk, ATM, Web payphone, medical and other embedded applications.

**2801460 for Pentium 4 Mobile processor is available based on quantity orders. Contact your supplier for details.*

Checklist

Your 2801460 package should include the items listed below.

- The 2801460 P4 embedded board
- This User's Manual
- 1 CD containing chipset drivers and flash memory utility
- Optional cables such as:
 - 2 IDE Ribbon Cables (40-pin & 44-pin)
 - 1 COM Port Cable

Specifications

Product Name	2801460
Form Factor	Mini ITX (170mm x 170mm)
CPU Type	Socket 478 Intel Pentium 4 or Intel Pentium 4 Mobile
CPU Voltage	1.1V~1.75V
System Speed	Pentium 4 1.7G~3.06G; P4-M 1.7G~2.2GHz
Front Side Bus	Pentium 4 400/533MHz; P4-M 400 MHz 100MHz x 4
Green /APM	APM1.2
CPU Socket	Socket 478
Chipset	Intel 845GV Chipset GMCH: 82845GV 760 pin FC-BGA ICH4: 82801DB 421 pin BGA FWH
BIOS	Award BIOS Support ACPI Function
Cache	128K/256K/512K Level 2 (CPU integrated)
VGA	82845GV built-in, AGP 4X,support CRT
LAN	Realtek 8100BL 10/100Mb LAN Controller
Memory type	1 x DDR 2.5V PC200/266/333 DDR SDRAM (without ECC Function) DIMM Module, Max. capacity - 1GB
LPC I/O	Winbond W83627HF: Parallelx1, COM1, COM2 (RS-232), FDC 1.44MB (Slim), Hardware monitor (3 thermal inputs, 6 voltage monitor inputs, VID0-4, 1 chassis open detection, 2 Fan Header)
Digital I/O	4 IN 4 OUT 2X5 Pin header
RTC/CMOS	ICH4 Built-in
Battery	Lithium Battery
Keyboard / Mouse	PS/2 Keyboard and PS/2 Mouse Connectors
D-type connectors	PS/2 keyboard/Mouse, VGA (CRT), RJ-45, COM1, Print, USBx2, Line out, Line in, Mic.
Local bus IDE (ICH4 built-in)	IDE1 40-pin box header (Ultra DMA 33/66/100); IDE2 44-pin header
Secondary I/O	Fintek F81216D COM3, 4 (RS232)
Expansion slots	PCI slot x 1 (supports 2 Bus master)
Audio	ICH4 Built-in Sound controller + AC97 Codec ALC 650 6 Channel (Line-out, Line-in, Mic.)
Power Connector	ATX 12V(4 pin)
USB	4 ports, USB 2.0
Watchdog Timer	Yes (256 segments: 0,1,2,...255 sec/min)
Power Voltages	+5V, +12V, -12V, 5VSB, 3.3V (for 2801460)
Other Features	Modem Wakeup, LAN Wakeup
Dimensions	170 mm x 170mm

Board Dimensions

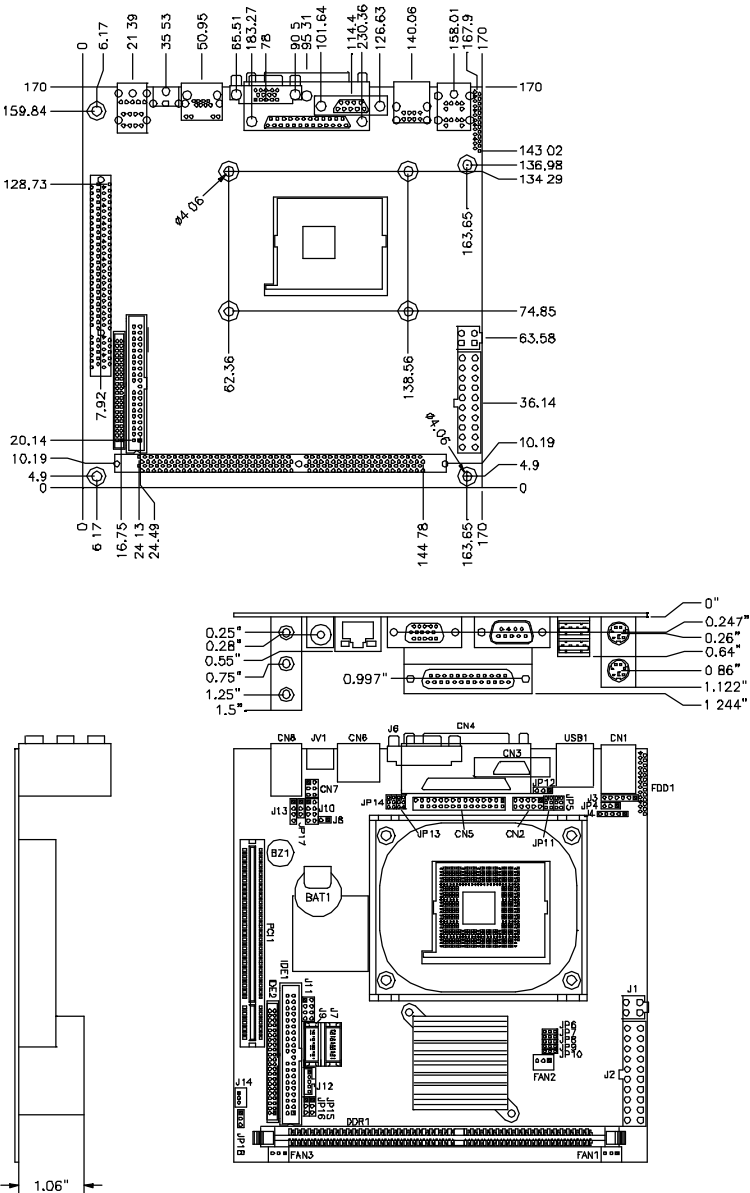

Installations

This section provides information on how to use the jumpers and connectors on the 2801460 in order to set up a workable system. The topics covered are:

Installing the CPU	6
Installing the Memory.....	7
Setting the Jumpers	8
Connectors on 2801460	13
Watchdog Timer Configuration	22
Digital I/O Sample Code.....	26

Installing the CPU

The 2801460 embedded board supports a Socket 478 processor socket for Intel Pentium 4 processors or Pentium 4 Mobile processors.

The Socket 478 processor socket comes with a lever to secure the processor. Raise this lever to about a 90° angle to allow the insertion of the processor. Place the processor into the socket by making sure the notch on the corner of the CPU corresponds with the notch on the inside of the socket. Once the processor has slide into the socket, return the lever to the lock position. Refer to the figures below.

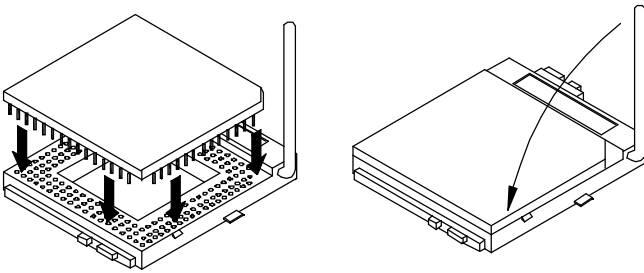

After you have installed the processor into the socket, check if the jumpers for the CPU type and speed are correct.

NOTE: *Ensure that the CPU heat sink and the CPU top surface are in total contact to avoid CPU overheating problem that would cause your system to hang or be unstable.*

Installing the Memory

The 2801460 embedded board supports one DDR memory sockets for a maximum total memory of 1GB in DDR memory type. The memory module capacities supported are 128MB, 256MB, 512MB and 1GB. The following table lists the supported DDR DIMM configurations. Intel 845GV supports configurations defined in the JEDEC DDR DIMM specification only. Non-JEDEC standard DIMMs such as double-sided x16 DDR SDRAM DIMMs are not supported.

Installing and Removing Memory Modules

To install the DDR modules, locate the memory slot on the embedded board and perform the following steps:

1. Hold the DDR module so that the key of the DDR module align with those on the memory slot.
2. Gently push the DDR module in an upright position until the clips of the slot close to hold the DDR module in place when the DDR module touches the bottom of the slot.
3. To remove the DDR module, press the clips with both hands.

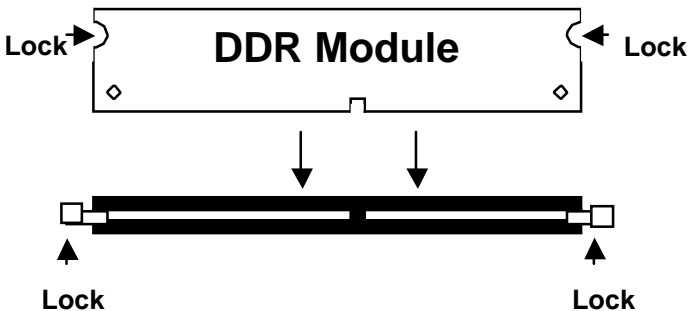

Setting the Jumpers

Jumpers are used on 2801460 to select various settings and features according to your needs and applications. Contact your supplier if you have doubts about the best configuration for your needs. The following lists the connectors on 2801460 and their respective functions.

Jumper Locations on 2801460.....	9
Configuring the CPU Frequency.....	10
JP4: Keyboard/Mouse Power Setting	10
J8: RTL8100BL LAN Enable/Disable.....	10
JP16: LVDS Panel Power Select	10
JP17: Clear CMOS Contents.....	11
JP11: COM1 RS232 +5V / +12V Power Setting.....	11
JP5: COM2 RS232 +5V / +12V Power Setting.....	11
JP14: COM3 RS232 +5V / +12V Power Setting.....	11
JP13: COM4 RS232 +5V / +12V Power Setting.....	12
JP18: AT or ATX Power Setting.....	12

Configuring the CPU Frequency

The 2801460 embedded board does not provide DIP switches to configure the processor speed (CPU frequency).

JP4: Keyboard/Mouse Power Setting



Pin #	Signal Name
1	Vcc
2	KB/MS power
3	+5VSB

Default: 1-2 short

J8: RTL8100BL LAN Enable/Disable

J8	10/100Mb LAN
<p>Open</p>	Enable
<p>Short</p>	Disable



JP16: LVDS Panel Power Select

JP16	
<p>1 2 3</p>	3.3V (default)
<p>1 2 3</p>	5V

Note: The LVDS panel resolution can be configured in the BIOS Setup.

JP17: Clear CMOS Contents

Use JP4 to clear the CMOS contents. *Note that the ATX-power connector should be disconnected from the board before clearing CMOS.*

JP17	Setting	Function
	Pin 1-2 Short/Closed	Normal
	Pin 2-3 Short/Closed	Clear CMOS

JP11: COM1 RS232 +5V / +12V Power Setting

Pin #	Signal Name	JP11	Signal Name	Pin #
1	RI		+12V	2
3	RI (Default)		RI (Default)	4
5	RI		+5V	6

COM1 Settings: Pin 1-2 short = +12V, Pin 5-6 short = +5V, Pin 3-4 Standard COM Port

JP5: COM2 RS232 +5V / +12V Power Setting

Pin #	Signal Name	JP2	Signal Name	Pin #
1	RI		+12V	2
3	RI (Default)		RI (Default)	4
5	RI		+5V	6

COM2 Settings: Pin 1-2 short = +12V, Pin 5-6 short = +5V, Pin 3-4 Standard COM Port

JP14: COM3 RS232 +5V / +12V Power Setting

Pin #	Signal Name	JP14	Signal Name	Pin #
1	RI		+12V	2
3	RI (Default)		RI (Default)	4
5	RI		+5V	6

COM3 Settings: Pin 1-2 short = +12V, Pin 5-6 short = +5V, Pin 3-4 Standard COM Port

JP13: COM4 RS232 +5V / +12V Power Setting

Pin #	Signal Name	JP13	Signal Name	Pin #
1	RI		+12V	2
3	RI (Default)		RI (Default)	4
5	RI		+5V	6

COM4 Settings: Pin 1-2 short = +12V, Pin 6-5 short = +5V, Pin 3-4 Standard COM Port

JP18: AT or ATX Power Setting

JP18	Setting	Function
	Pin 1-2 Short/Closed	ATX Power (Default)
	Pin 2-3 Short/Closed	AT Power

Connectors on 2801460

The connectors on 2801460 allows you to connect external devices such as keyboard, floppy disk drives, hard disk drives, printers, etc. The following table lists the connectors on 2801460 and their respective functions.

Connector Locations on 2801460.....	14
JV1, JP15: TV out Connector (RCA Jack and 3-pin Header)	15
J1: ATX 12V/+12V Power Connector	15
J2: ATX Power Supply Connector	15
J3: External PS/2 Keyboard Connector	16
J4: IrDA Connector.....	16
CN5: Serial Ports	16
FDD1: Floppy Drive Connector	17
IDE1, IDE2: EIDE Connectors.....	17
FAN1, FAN3: System Fan Power Connector	18
FAN2: CPU Fan Power Connector	18
J9, J7: LVDS Connectors (1st channel, 2nd channel).....	19
J10: USB Connectors	19
J11: System Function Connector	19
J12: Panel Inverter Power Connector	20
J13: CD-In Audio Connector	20
J14: Wake On LAN Connector	20
CN2: Digital 4-in 4-out I/O Connector	20
CN6: RJ45 Connector	21
CN7: External Audio Connector.....	21
CN8: Line Out, Line In, Mic Connector	21

Connector Locations on 2801460

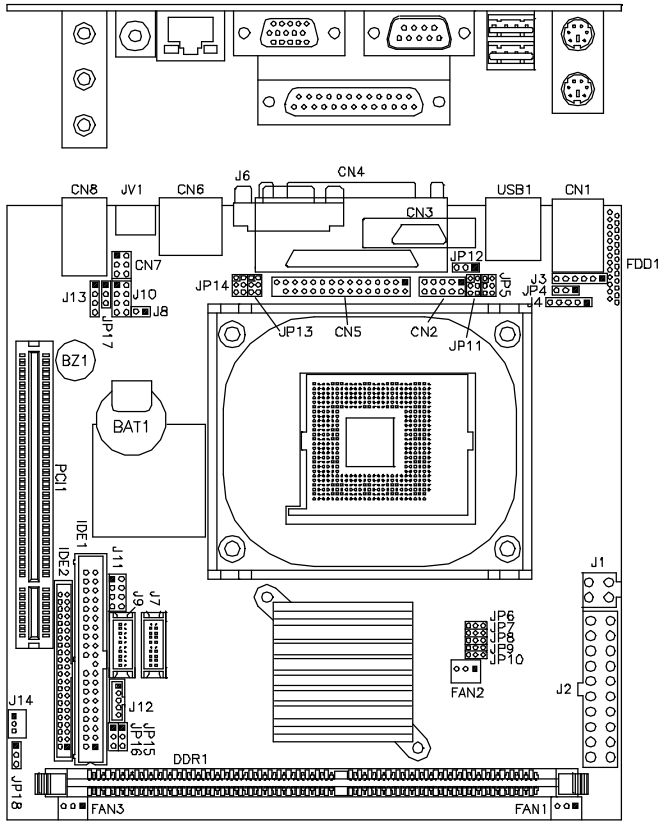

Connector on 2801460	Page
JV1, JP15: TV out Connector (RCA Jack and 3-pin Header)	15
J1: ATX 12V/+12V Power Connector	15
J2: ATX Power Supply Connector	15
J3: External PS/2 Keyboard Connector	15
J4: IrDA Connector	16
CN5: Serial Ports	16
IDE1, IDE2: EIDE Connectors	17
FDD1: Floppy Drive Connector	17
FAN1, FAN3: System Fan Power Connector	18
FAN2: CPU Fan Power Connector	18
J9, J7: LVDS Connectors (1st channel, 2nd channel)	19
J10: USB Connectors	19
J11: System Function Connector	19
J12: Panel Inverter Power Connector	20
J14: Wake On LAN Connector	20
J13: CD-In Audio Connector	20
CN7: External Audio Connector	20
CN8: J7: Line Out, Line In, Mic Connector	22
CN2: Digital 4-in 4-out I/O Connector	22

JV1, JP15: TV out Connector (RCA Jack and 3-pin Header)

The locations of the TV out connector are as below:

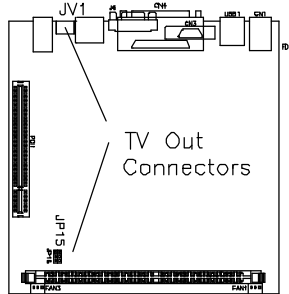

J1: ATX 12V/+12V Power Connector

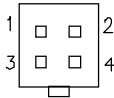

Pin #	Signal Name
1	Ground
2	Ground
3	+12V
4	+12V

J2: ATX Power Supply Connector

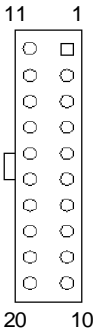

Signal Name	Pin #	Pin #	Signal Name
3.3V	11	1	3.3V
-12V	12	2	3.3V
Ground	13	3	Ground
PS-ON	14	4	+5V
Ground	15	5	Ground
Ground	16	6	+5V
Ground	17	7	Ground
-5V	18	8	Power good
+5V	19	9	5VSB
+5V	20	10	+12V

J3: External PS/2 Keyboard Connector

J3, a 6-pin header connector, has functions for external keyboard.



Signal Name	Pin #
Vcc	1
Internal KB CLK	2
External KB CLK	3
Internal KB data	4
External KB data	5
Ground	6

Default: 2-3 short, 4-5 short for internal CN1 keyboard
 For external keyboard, use 1, 3, 5, 6 pin

J4: IrDA Connector

J4 is used for an optional IrDA connector for wireless communication.

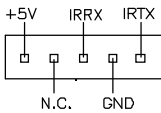

Pin #	Signal Name
1	+5V
2	No connect
3	Ir RX
4	Ground
5	Ir TX

CN5: Serial Ports



Pin #	Signal Name (RS-232)
1	DCD, Data carrier detect
2	RXD, Receive data
3	TXD, Transmit data
4	DTR, Data terminal ready
5	Ground
6	DSR, Data set ready
7	RTS, Request to send
8	CTS, Clear to send
9	RI, Ring indicator
10	No Connect.

FDD1: Floppy Drive Connector

FDD1 is a slim 26-pin connector and will support up to 2.88MB FDD.

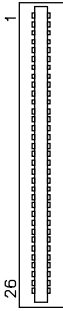

Signal Name	Pin #	Pin #	Signal Name
VCC	1	2	INDEX
VCC	3	4	DRV_SEL
VCC	5	6	DSK_CH
NC	7	8	NC
NC	9	10	MOTOR
DINST	11	12	DIR
NC	13	14	STEP
GND	15	16	WDATA
GND	17	18	WGATE
GND	19	20	TRACK
NC	21	22	WPROT
GND	23	24	RDATA
GND	25	26	SIDE

IDE1, IDE2: EIDE Connectors

IDE1: Primary IDE Connector

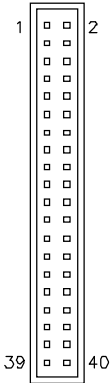

Signal Name	Pin #	Pin #	Signal Name
Reset IDE	1	2	Ground
Host data 7	3	4	Host data 8
Host data 6	5	6	Host data 9
Host data 5	7	8	Host data 10
Host data 4	9	10	Host data 11
Host data 3	11	12	Host data 12
Host data 2	13	14	Host data 13
Host data 1	15	16	Host data 14
Host data 0	17	18	Host data 15
Ground	19	20	Protect pin
DRQ0	21	22	Ground
Host IOW	23	24	Ground
Host IOR	25	26	Ground
IOCHRDY	27	28	Host ALE
DACK0	29	30	Ground
IRQ14	31	32	No connect
Address 1	33	34	No connect
Address 0	35	36	Address 2
Chip select 0	37	38	Chip select 1
Activity	39	40	Ground

IDE2: Secondary IDE Connector

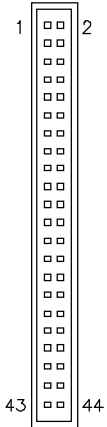

Signal Name	Pin #	Pin #	Signal Name
Reset IDE	1	2	Ground
Host data 7	3	4	Host data 8
Host data 6	5	6	Host data 9
Host data 5	7	8	Host data 10
Host data 4	9	10	Host data 11
Host data 3	11	12	Host data 12
Host data 2	13	14	Host data 13
Host data 1	15	16	Host data 14
Host data 0	17	18	Host data 15
Ground	19	20	Key
DRQ0	21	22	Ground
Host IOW	23	24	Ground
Host IOR	25	26	Ground
IOCHRDY	27	28	Host ALE
DACK0	29	30	Ground
IRQ14	31	32	No connect
Address 1	33	34	No connect
Address 0	35	36	Address 2
Chip select 0	37	38	Chip select 1
Activity	39	40	Ground
Vcc	41	42	Vcc
Ground	43	44	N.C.

FAN1, FAN3: System Fan Power Connector

FAN1, FAN2 is a 3-pin header for system fans. The fan must be a 12V (500mA) fan.

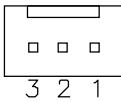

Pin #	Signal Name
1	Ground
2	+12V
3	Rotation detection

FAN2: CPU Fan Power Connector

FAN3 is a 3-pin header for the CPU fan. The fan must be a 12V fan.

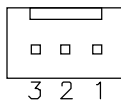

Pin #	Signal Name
1	Ground
2	+12V
3	Rotation detection

J9, J7: LVDS Connectors (1st channel, 2nd channel)

The LVDS connectors, available on 2801460B only, are composed of the first channel (J9) and second channel (J7) to support 24-bit or 48-bit.

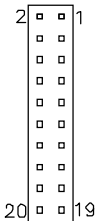

Signal Name	Pin #	Pin #	Signal Name
TX0-	2	1	TX0+
Ground	4	3	Ground
TX1-	6	5	TX1+
5V/3.3V	8	7	Ground
TX3-	10	9	TX3+
TX2-	12	11	TX2+
Ground	14	13	Ground
TXC-	16	15	TXC+
5V/3.3V	18	17	ENABKL
+12V	20	19	+12V

J10: USB Connectors

The following table shows the pin outs of the USB pin headers connectors. Overall, the one pin header support four USB ports (USB 2.0 compliant).

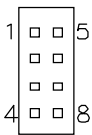

Signal Name	Pin	Pin	Signal Name
Vcc	1	5	Ground
USB0-	2	6	USB1+
USB0+	3	7	USB1-
Ground	4	8	Vcc

J11: System Function Connector



Signal Name	Pin	Pin	Signal Name
Ground	1	2	PS_ON
Power LED	3	4	Ground
5V	5	6	HDD Active
Ground	7	8	Reset

ATX power on switch: Pins 1-2

Power LED: Pins 3-4

HDD LED: Pins 5-6

Reset switch: Pins 7-8

J12: Panel Inverter Power Connector

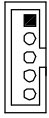

Pin #	Signal Name
1	+12V
2	Ground
3	ENABKL
4	NC
5	+5V

J13: CD-In Audio Connector

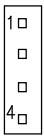

Pin #	Signal Name
1	CD Audio R
2	Ground
3	Ground
4	CD Audio L

J14: Wake On LAN Connector

J14 is a 3-pin header for the Wake On LAN function on the CPU card. Wake On LAN will function properly only with an ATX power supply with 5VSB that has 200mA.

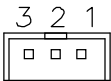

Pin #	Signal Name
1	+5VSB
2	Ground
3	-PME

CN2: Digital 4-in 4-out I/O Connector

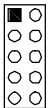

Signal Name	Pin	Pin	Signal Name
Ground	1	2	Vcc
Out3	3	4	Out1
Out2	5	6	Out0
Int3	7	8	Int1
Int2	9	10	Int0

CN6: RJ45 Connector

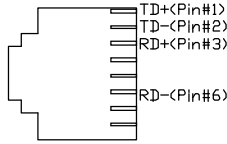

CN7: External Audio Connector

CN7 is a 6-pin header that is used to connect to the optional audio cable card that integrates jacks for Line Out and Mic.



Signal Name	Pin #	Pin #	Signal Name
LINEOUT R	1	2	LINEOUT L
Ground	3	4	Ground
MIC 1	5	6	MIC 2

CN8: Line Out, Line In, Mic Connector

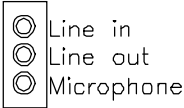

Watchdog Timer Configuration

The WDT is used to generate a variety of output signals after a user programmable count. The WDT is suitable for use in the prevention of system lock-up, such as when software becomes trapped in a deadlock. Under these sort of circumstances, the timer will count to zero and the selected outputs will be driven. Under normal circumstance, the user will restart the WDT at regular intervals before the timer counts to zero.

SAMPLE CODE:

This code and information is provided "as is" without warranty of any kind, either expressed or implied, including but not limited to the implied warranties of merchantability and/or fitness for a particular purpose.

```

;[]=====
; Name : Enable_And_Set_Watchdog
; IN   : AL - 1sec ~ 255sec
; OUT  : None
;[]=====
Enable_And_Set_Watchdog Proc Near
    push    ax                ;save time interval
    call   Unlock_Chip

    mov     cl, 2Bh
    call   Read_Reg
    and    al, NOT 10h
    call   Write_Reg         ;set GP24 as WDTO

    mov     cl, 07h
    mov     al, 08h
    call   Write_Reg         ;switch to LD8

```

```

    mov cl, 0F5h
    call Read_Reg
    and al, NOT 08h
    call Write_Reg      ;set count mode as second

    pop ax
    mov    cl, 0F6h
    call Write_Reg      ;set watchdog timer

    mov    al, 01h
    mov    cl, 30h
    call Write_Reg      ;watchdog enabled

    call Lock_Chip
    ret
Enable_And_Set_Watchdog Endp
;[]=====
; Name : Disable_Watchdog
; IN   : None
; OUT  : None
;[]=====
Disable_Watchdog Proc Near
    call Unlock_Chip
    mov    cl, 07h
    mov    al, 08h
    call Write_Reg      ;switch to LD8

    xor al, al
    mov    cl, 0F6h
    call Write_Reg      ;clear watchdog timer

    xor al, al
    mov    cl, 30h
    call Write_Reg      ;watchdog disabled

    call Lock_Chip
    ret
Disable_Watchdog Endp
;[]=====

```

INSTALLATIONS

; Name : Unlock_Chip

; IN : None

; OUT : None

;[]=====

Unlock_Chip Proc Near

Mov dx, 4Eh

mov al, 87h

out dx, al

out dx, al

ret

Unlock_Chip Endp

;[]=====

; Name : Lock_Chip

; IN : None

; OUT : None

;[]=====

Unlock_Chip Proc Near

mov dx, 4Eh

mov al, 0AAh

out dx, al

ret

Unlock_Chip Endp

;[]=====

; Name : Write_Reg

; IN : CL - register index

; AL - Value to write

; OUT : None

;[]=====

Write_Reg Proc Near

push ax

mov dx, 4Eh

mov al, cl

out dx, al

pop ax

inc dx

out dx, al

ret

Write_Reg Endp

;[]=====

```
; Name : Read_Reg  
; IN : CL - register index  
; OUT : AL - Value to read
```

```
;[=====
```

```
====  
Read_Reg Proc Near  
    Mov al, cl  
    mov  dx, 4Eh  
    out dx, al  
    inc dx  
    in  al, dx  
    ret
```

```
Read_Reg Endp
```

```
;[=====
```

Digital I/O Sample Code

Filename: W627hf.h

```
//=====
//
// THIS CODE AND INFORMATION IS PROVIDED "AS IS" WITHOUT WARRANTY OF ANY
// KIND, EITHER EXPRESSED OR IMPLIED, INCLUDING BUT NOT LIMITED TO THE
// IMPLIED WARRANTIES OF MERCHANTABILITY AND/OR FITNESS FOR A
// PARTICULAR
// PURPOSE.
//
//=====
#ifndef __W627HF_H
#define __W627HF_H                1
//=====
#define W627_IOBASE                0x4E
//=====
#define W627HF_INDEX_PORT    (W627_IOBASE+0)
#define W627HF_DATA_PORT    (W627_IOBASE+1)
//=====
#define W627HF_REG_LD        0x07
//=====
#define W627HF_UNLOCK        0x87
#define W627HF_LOCK          0xAA
//=====
void Set_W627HF_LD( unsigned char);
void Set_W627HF_Reg( unsigned char, unsigned char);
unsigned char Get_W627HF_Reg( unsigned char);
//=====
#endif    // __W627HF_H
```

```

Filename: W627hf.cpp
//=====
//
// THIS CODE AND INFORMATION IS PROVIDED "AS IS" WITHOUT WARRANTY OF ANY
// KIND, EITHER EXPRESSED OR IMPLIED, INCLUDING BUT NOT LIMITED TO THE
// IMPLIED WARRANTIES OF MERCHANTABILITY AND/OR FITNESS FOR A
// PARTICULAR
// PURPOSE.
//
//=====
#include "W627HF.H"
#include <dos.h>
//=====
void Unlock_W627HF(void);
void Lock_W627HF(void);
//=====
void Unlock_W627HF(void)
{
    outportb(W627HF_INDEX_PORT, W627HF_UNLOCK);
    outportb(W627HF_INDEX_PORT, W627HF_UNLOCK);
}
//=====
void Lock_W627HF(void)
{
    outportb(W627HF_INDEX_PORT, W627HF_LOCK);
}
//=====
void Set_W627HF_LD(unsigned char LD)
{
    Unlock_W627HF();
    outportb(W627HF_INDEX_PORT, W627HF_REG_LD);
    outportb(W627HF_DATA_PORT, LD); Lock_W627HF();
}
//=====
void Set_W627HF_Reg(unsigned char REG, unsigned char DATA)
{
    Unlock_W627HF();
    outportb(W627HF_INDEX_PORT, REG);
    outportb(W627HF_DATA_PORT, DATA);
    Lock_W627HF();
}
//=====
unsigned char Get_W627HF_Reg(unsigned char REG)
{
    unsigned char Result;
    Unlock_W627HF();
    outportb(W627HF_INDEX_PORT, REG);
    Result = inportb(W627HF_DATA_PORT);
    Lock_W627HF();
    return Result;
}
//=====

```

INSTALLATIONS

File of the Main.cpp

```
//=====
// THIS CODE AND INFORMATION IS PROVIDED "AS IS" WITHOUT WARRANTY OF ANY
// KIND, EITHER EXPRESSED OR IMPLIED, INCLUDING BUT NOT LIMITED TO THE
// IMPLIED WARRANTIES OF MERCHANTABILITY AND/OR FITNESS FOR A
// PARTICULAR
// PURPOSE.
//=====
#include <dos.h>
#include <conio.h>
#include <stdio.h>
#include <stdlib.h>
#include "W627HF.H"
//=====
void ClrKbBuf(void);
int main (int argc, char *argv[]);
//=====
int main (int argc, char *argv[])
{
    unsigned char ucDO = 0;                //data for digital output
    unsigned char ucDI;                    //data for digital input unsigned
    char ucBuf;

    Set_W627HF_LD( 0x07);                  //switch to logic device 7

    Set_W627HF_Reg(0xF1, 0x00);           //clear
    ucDI = Get_W627HF_Reg(0xF1) & 0x0F;

    ClrKbBuf();
    while(1)
    {
        ucDO++;
        Set_W627HF_Reg(0xF1, ((ucDO & 0x0F) << 4));
        ucBuf = Get_W627HF_Reg(0xF1) & 0x0F;
        if (ucBuf != ucDI)
        {
            ucDI = ucBuf;
            printf("Digital I/O Input Changed. Current Data is 0x%X\n",ucDI);
        }

        if (kbhit())
        {
            getch();
            break;
        }
        delay(500);
    }
    return 0;
}
//=====
void ClrKbBuf(void)
{
    while(kbhit())
    {
        getch();
    }
}
```

//-----

BIOS Setup

This chapter describes the different settings available in the Award BIOS that comes with the motherboard. The topics covered in this chapter are as follows:

BIOS Introduction.....	31
BIOS Setup.....	31
Standard CMOS Setup	33
Advanced BIOS Features	36
Advanced Chipset Features.....	39
Integrated Peripherals.....	42
Power Management Setup	45
PNP/PCI Configurations	48
PC Health Status	49
Frequency/Voltage Control.....	50
Load Fail-Safe Defaults.....	51
Load Setup Defaults.....	51
Set Supervisor/User Password	51
Save & Exit Setup.....	51
Exit Without Saving.....	51

BIOS Introduction

The Award BIOS (Basic Input/Output System) installed in your computer system's ROM supports Intel Pentium 4 processors. The BIOS provides critical low-level support for a standard device such as disk drives, serial ports and parallel ports. It also adds virus and password protection as well as special support for detailed fine-tuning of the chipset controlling the entire system.

BIOS Setup

The Award BIOS provides a Setup utility program for specifying the system configurations and settings. The BIOS ROM of the system stores the Setup utility. When you turn on the computer, the Award BIOS is immediately activated. Pressing the key immediately allows you to enter the Setup utility. If you are a little bit late pressing the key, POST (Power On Self Test) will continue with its test routines, thus preventing you from invoking the Setup. If you still wish to enter Setup, restart the system by pressing the "Reset" button or simultaneously pressing the <Ctrl>, <Alt> and <Delete> keys. You can also restart by turning the system Off and back On again. The following message will appear on the screen:

```
Press <DEL> to Enter Setup
```

In general, you press the arrow keys to highlight items, <Enter> to select, the <PgUp> and <PgDn> keys to change entries, <F1> for help and <Esc> to quit.

When you enter the Setup utility, the Main Menu screen will appear on the screen. The Main Menu allows you to select from various setup functions and exit choices.

BIOS SETUP

CMOS Setup Utility – Copyright © 1984-2001 Award Software

Standard CMOS Features	Frequency/Voltage Control
Advanced BIOS Features	Load Fail-Safe Defaults
Advanced Chipset Features	Load Optimized Defaults
Integrated Peripherals	Set Supervisor Password
Power Management Setup	Set User Password
PnP/PCI Configurations	Save & Exit Setup
PC Health Status	Exit Without Saving
ESC : Quit	á â à ß : Select Item
F10 : Save & Exit Setup	
Time, Date, Hard Disk Type...	

The section below the setup items of the Main Menu displays the control keys for this menu. At the bottom of the Main Menu just below the control keys section, there is another section, which displays information on the currently highlighted item in the list.

Note: *If the system cannot boot after making and saving system changes with Setup, the Award BIOS supports an override to the CMOS settings that resets your system to its default.*

Warning: *It is strongly recommended that you avoid making any changes to the chipset defaults. These defaults have been carefully chosen by both Award and your system manufacturer to provide the absolute maximum performance and reliability. Changing the defaults could cause the system to become unstable and crash in some cases.*

Standard CMOS Setup

“Standard CMOS Setup” choice allows you to record some basic hardware configurations in your computer system and set the system clock and error handling. If the motherboard is already installed in a working system, you will not need to select this option. You will need to run the Standard CMOS option, however, if you change your system hardware configurations, the onboard battery fails, or the configuration stored in the CMOS memory was lost or damaged.

CMOS Setup Utility – Copyright © 1984-2001 Award Software
Standard CMOS Features

Date (mm:dd:yy)	Tue, Mar 26 2001	Item Help
Time (hh:mm:ss)	00 : 00 : 00	Menu Level
IDE Primary Master	Press Enter 13020 MB	Change the day, month, Year and century
IDE Primary Slave	Press Enter None	
IDE Secondary Master	Press Enter None	
IDE Secondary Slave	Press Enter None	
Drive A	1.44M, 3.5 in.	
Drive B	None	
Video	EGA/VGA	
Halt On	All Errors	
Base Memory	640K	
Extended Memory	129024K	
Total Memory	130048K	

At the bottom of the menu are the control keys for use on this menu. If you need any help in each item field, you can press the <F1> key. It will display the relevant information to help you. The memory display at the lower right-hand side of the menu is read-only. It will adjust automatically according to the memory changed. The following describes each item of this menu.

Date

The date format is:

Day : Sun to Sat
Month : 1 to 12
Date : 1 to 31
Year : 1994 to 2079

To set the date, highlight the “Date” field and use the PageUp/ PageDown or +/- keys to set the current time.

Time

The time format is: **Hour** : 00 to 23
 Minute : 00 to 59
 Second : 00 to 59

To set the time, highlight the “Time” field and use the <PgUp>/ <PgDn> or +/- keys to set the current time.

IDE Primary HDDs / IDE Secondary HDDs

The onboard PCI IDE connectors provide Primary and Secondary channels for connecting up to four IDE hard disks or other IDE devices. Each channel can support up to two hard disks; the first is the “Master” and the second is the “Slave”.

Press <Enter> to configure the hard disk. The selections include Auto, Manual, and None. Select ‘Manual’ to define the drive information manually. You will be asked to enter the following items.

CYLS : Number of cylinders
HEAD : Number of read/write heads
PRECOMP : Write precompensation
LANDZ : Landing zone
SECTOR : Number of sectors

The Access Mode selections are as follows:

Auto
Normal (HD < 528MB)
Large (for MS-DOS only)
LBA (HD > 528MB and supports
Logical Block Addressing)

Drive A / Drive B

These fields identify the types of floppy disk drive A or drive B that has been installed in the computer. The available specifications are:

360KB	1.2MB	720KB	1.44MB	2.88MB
5.25 in.	5.25 in.	3.5 in.	3.5 in.	3.5 in.

Video

This field selects the type of video display card installed in your system. You can choose the following video display cards:

EGA/VGA	For EGA, VGA, SEGA, SVGA or PGA monitor adapters. (default)
CGA 40	Power up in 40 column mode.
CGA 80	Power up in 80 column mode.
MONO	For Hercules or MDA adapters.

Halt On

This field determines whether or not the system will halt if an error is detected during power up.

No errors	The system boot will not be halted for any error that may be detected.
All errors	Whenever the BIOS detects a non-fatal error, the system will stop and you will be prompted.
All, But Keyboard	The system boot will not be halted for a keyboard error; it will stop for all other errors
All, But Diskette	The system boot will not be halted for a disk error; it will stop for all other errors.
All, But Disk/Key	The system boot will not be halted for a keyboard or disk error; it will stop for all others.

Advanced BIOS Features

This section allows you to configure and improve your system and allows you to set up some system features according to your preference.

CMOS Setup Utility – Copyright © 1984-2001 Award Software
Advanced BIOS Features

		ITEM HELP
Virus Warning	Disabled	Menu Level
CPU L1 and L2 Cache	Enabled	
Quick Power On Self Test	Enabled	
First Boot Device	Floppy	
Second Boot Device	HDD-0	
Third Boot Device	CDROM	
Boot Other Device	Enabled	
Swap Floppy Drive	Disabled	
Boot Up Floppy Seek	Disabled	
Boot Up Numlock Status	On	
Gate A20 Option	Fast	
Typematic Rate Setting	Disabled	
Typematic Rate (chars/Sec)	6	
Typematic Delay (Msec)	250	
Security Option	Setup	
APIC Mode	Enabled	
MPS Version Control for OS	1.4	
OS Select For DRAM>64MB	Non-OS2	
Report No FDD For WIN 95	Yes	
Small Logo (EPA) Show	Enabled	
		Allows you choose the VIRUS warning feature for IDE Hard Disk boot sector protection. If this function is enabled and someone attempt to write data into this area, BIOS will show a warning message on screen and alarm beep

Virus Warning

This item protects the boot sector and partition table of your hard disk against accidental modifications. If an attempt is made, the BIOS will halt the system and display a warning message. If this occurs, you can either allow the operation to continue or run an anti-virus program to locate and remove the problem.

CPU L1 and L2 Cache

Cache memory is additional memory that is much faster than conventional DRAM (system memory). CPUs from 486-type on up contain internal cache memory, and most, but not all, modern PCs have additional (external) cache memory. When the CPU requests data, the system transfers the requested data from the main DRAM into cache memory, for even faster access by the CPU. These items allow you to enable (speed up memory access) or disable the cache function. By default, these items are **Enabled**.

Quick Power On Self Test

When enabled, this field speeds up the Power On Self Test (POST) after the system is turned on. If it is set to **Enabled**, BIOS will skip some items.

First/Second/Third Boot Device

These fields determine the drive that the system searches first for an operating system. The options available include *Floppy*, *LS/ZIP*, *HDD-0*, *SCSI*, *CDROM*, *HDD-1*, *HDD-2*, *HDD-3*, *LAN* and *Disable*.

Boot Other Device

These fields allow the system to search for an operating system from other devices other than the ones selected in the First/Second/Third Boot Device.

Swap Floppy Drive

This item allows you to determine whether or not to enable Swap Floppy Drive. When enabled, the BIOS swaps floppy drive assignments so that Drive A becomes Drive B, and Drive B becomes Drive A. By default, this field is set to *Disabled*.

Boot Up Floppy Seek

This feature controls whether the BIOS checks for a floppy drive while booting up. If it cannot detect one (either due to improper configuration or its absence), it will flash an error message.

Boot Up NumLock Status

This allows you to activate the NumLock function after you power up the system.

Gate A20 Option

This field allows you to select how Gate A20 is worked. Gate A20 is a device used to address memory above 1 MB.

Typematic Rate Setting

When disabled, continually holding down a key on your keyboard will generate only one instance. When enabled, you can set the two typematic controls listed next. By default, this field is set to *Disabled*.

Typematic Rate (Chars/Sec)

When the typematic rate is enabled, the system registers repeated keystrokes speeds. Settings are from 6 to 30 characters per second.

Typematic Delay (Msec)

When the typematic rate is enabled, this item allows you to set the time interval for displaying the first and second characters. By default, this item is set to *250msec*.

Security Option

This field allows you to limit access to the System and Setup. The default value is *Setup*. When you select *System*, the system prompts for the User Password every time you boot up. When you select *Setup*, the system always boots up and prompts for the Supervisor Password only when the Setup utility is called up.

APIC Mode

APIC stands for Advanced Programmable Interrupt Controller. The default setting is *Enabled*.

MPS Version Control for OS

This option specifies the MPS (Multiprocessor Specification) version for your operating system. MPS version 1.4 added extended configuration tables to improve support for multiple PCI bus configurations and improve future expandability. The default setting is *1.4*.

OS Select for DRAM > 64MB

This option allows the system to access greater than 64MB of DRAM memory when used with OS/2 that depends on certain BIOS calls to access memory. The default setting is *Non-OS/2*.

Report No FDD For WIN 95

If you are using Windows 95/98 without a floppy disk drive, select *Enabled* to release IRQ6. This is required to pass Windows 95/98's SCT test. You should also disable the Onboard FDC Controller in the Integrated Peripherals screen when there's no floppy drive in the system. If you set this feature to *Disabled*, the BIOS will not report the missing floppy drive to Win95/98.

Small Logo (EPA) Show

The EPA logo appears at the right side of the monitor screen when the system is boot up. The default setting is *Enabled*.

Advanced Chipset Features

This Setup menu controls the configuration of the chipset.

CMOS Setup Utility – Copyright © 1984-2001 Award Software
Advanced Chipset Features

		ITEM HELP
DRAM Timing Selectable	By SPD	Menu Level
CAS Latency Time	2.5	
Active to Precharge Delay	6	
DRAM RAS# to CAS# Delay	3	
DRAM RAS# Precharge	3	
Turbo Mode	Disabled	
Memory Frequency For	Auto	
System BIOS Cacheable	Enabled	
Video BIOS Cacheable	Enabled	
Delayed Transaction	Enabled	
Delay Prior to Thermal	16 Min	
AGP Aperture Size (MB)	64	
** On-Chip VGA Setting **		
On-Chip VGA	Enabled	
On-Chip Frame Buffer Size	8MB	
Boot Display	Auto	
Panel Scaling	Auto	
Panel Type	800x600 LVDS	
TV Standard	Off	
Video Connector	Automatic	
TV Format	Auto	

DRAM Timing Selectable

This option refers to the method by which the DRAM timing is selected. The default is *By SPD*.

CAS Latency Time

You can select CAS latency time in HCLKs of 2/2 or 3/3. The system board designer should set the values in this field, depending on the DRAM installed. Do not change the values in this field unless you change specifications of the installed DRAM or the installed CPU. The choices are 2 and 3.

Active to Precharge Delay

The default setting for the Active to Precharge Delay is **6**.

DRAM RAS# to CAS# Delay

This option allows you to insert a delay between the RAS (Row Address Strobe) and CAS (Column Address Strobe) signals. This delay occurs when the SDRAM is written to, read from or refreshed. Reducing the delay improves the performance of the SDRAM.

DRAM RAS# Precharge

This option sets the number of cycles required for the RAS to accumulate its charge before the SDRAM refreshes. The default setting for the Active to Precharge Delay is **3**.

Memory Frequency For

This field sets the frequency of the DRAM memory installed. The default setting is *Auto*. The other settings are *DDR200* and *DDR266*.

System BIOS Cacheable

The setting of *Enabled* allows caching of the system BIOS ROM at F000h-FFFFh, resulting in better system performance. However, if any program writes to this memory area, a system error may result.

Video BIOS Cacheable

The Setting *Enabled* allows caching of the video BIOS ROM at C0000h-F7FFFh, resulting in better video performance. However, if any program writes to this memory area, a system error may result.

Delayed Transaction

The chipset has an embedded 32-bit posted write buffer to support delay transactions cycles. Select *Enabled* to support compliance with PCI specification version 2.1.

Delay Prior to Thermal

This field activates the CPU thermal function after the systems boots for the set number of minutes. The options are *16Min* and *64Min*.

AGP Aperture Size

The field sets aperture size of the graphics. The aperture is a portion of the PCI memory address range dedicated for graphics memory address space. Host cycles that hit the aperture range are forwarded to the AGP without any translation. The default setting is *64M*.

On-Chip VGA

By default, the On-Chip VGA or chipset-integrated VGA is *Enabled*.

On-Chip Frame Buffer Size

The On-Chip Frame Buffer Size can be set us 1MB or 8MB. This memory is shared with the system memory.

Boot Display

Boot Display determines the display output device where the system boots. The options are Auto, CRT and TV.

Panel Scaling

Setting this field to choose the initial state of Panel Fitting. A new state will overwrite the initial state and be remembered if Panel Fitting Hotkey is requested. Panel Fitting can only be enabled when in LFP only display. This panel fitting state is checked to update the hardware status after changing Video mode or Switching Display Devices

Panel Type

This field sets panel type with the resolution and interface information. The default setting is *800x 600 LVDS*.

TV Standard

This field sets the TV Standard as NTSC, PAL, SECAM or can be set off. The default setting is *Off*.

Video Connector

The video connector field selects the video connector as automatic, Composite, Component, or Both.

TV Format

This field sets the TV format that can be applied. The default setting is *Auto*.

Integrated Peripherals

This section sets configurations for your hard disk and other integrated peripherals.

CMOS Setup Utility – Copyright © 1984-2001 Award Software
 Integrated Peripherals

			ITEM HELP
On-Chip Primary PCI IDE	Enabled		Menu Level
IDE Primary Master PIO	Auto		
IDE Primary Slave PIO	Auto		
IDE Primary Master UDMA	Auto		
IDE Primary Slave UDMA	Auto		
On-Chip Secondary PCI IDE	Enabled		
IDE Secondary Master PIO	Auto		
IDE Secondary Slave PIO	Auto		
IDE Secondary Master UDMA	Auto		
IDE Secondary Slave UDMA	Auto		
USB Controller	Enabled		
USB 2.0 Controller	Disabled		
USB Keyboard Support	Disabled		
AC97 Audio	Auto		
Init Display First	PCI Slot		
IDE HDD Block Mode	Enabled		
POWER ON Function	BUTTON Only		
Onboard FDC Controller	Enabled		
Onboard Serial Port 1	3F8/IRQ4		
Onboard Serial Port 2	2F8/IRQ3		
UART Mode Select	Normal		
Onboard Parallel Port	378/IRQ7		
Parallel Port Mode	SPP		
PWRON After PWR-Fail	Off		
Onboard Serial Port 3	3E8H		
Serial Port 3 Use IRQ	IRQ10		
Onboard Serial Port 4	2E8H		
Serial Port 4 Use IRQ	IRQ11		

OnChip Primary/Secondary PCI IDE

The integrated peripheral controller contains an IDE interface with support for two IDE channels. Select *Enabled* to activate each channel separately.

IDE Primary/Secondary Master/Slave PIO

These fields allow your system hard disk controller to work faster. Rather than have the BIOS issue a series of commands that transfer to or from the disk drive, PIO (Programmed Input/Output) allows the BIOS to communicate with the controller and CPU directly.

The system supports five modes, numbered from 0 (default) to 4, which primarily differ in timing. When Auto is selected, the BIOS will select the best available mode.

IDE Primary/Secondary Master/Slave UDMA

These fields allow your system to improve disk I/O throughput to 33Mb/sec with the Ultra DMA/33 feature. The options are *Auto* and *Disabled*.

USB Controller

The options for this field are *Enabled* and *Disabled*. By default, this field is set to *Enabled*.

USB 2.0 Controller

The options for this field are *Enabled* and *Disabled*. By default, this field is set to *Disabled*. In order to use USB 2.0, necessary OS drivers must be installed first.

USB Keyboard Support

The options for this field are *Enabled* and *Disabled*. By default, this field is set to *Disabled*.

AC97 Audio

The default setting of the AC97 Audio is *Auto*.

Init Display First

This field allows the system to initialize first the VGA card on chip or the display on the PCI Slot. By default, the *PCI Slot* VGA is initialized first.

IDE HDD Block Mode

This field allows your hard disk controller to use the fast block mode to transfer data to and from your hard disk drive.

Power On Function

This field sets how the system can be powered on from a system off state. The default setting is *Button Only*.

Onboard FDC Controller

Select *Enabled* if your system has a floppy disk controller (FDC) installed on the motherboard and you wish to use it. If you install an add-in FDC or the system has no floppy drive, select *Disabled* in this field. This option allows you to select the onboard FDD port.

Onboard Serial/Parallel Port

These fields allow you to select the onboard serial and parallel ports and their addresses. The default values for these ports are:

Serial Port 1	3F8H/IRQ4
Serial Port 2	2F8H/IRQ3
Serial Port 3	3E8H/IRQ10
Serial Port 4	2E8H/IRQ11
Parallel Port	378H/IRQ7

UART Mode Select

This field determines the UART 2 mode in your computer. The default value is *Normal*. Other options include *IrDA* and *ASKIR*.

Parallel Port Mode

This field allows you to determine parallel port mode function.

SPP	Standard Printer Port
EPP	Enhanced Parallel Port
ECP	Extended Capabilities Port

PWRON After PWR-Fail

This field sets the system power status whether on or off when power returns from a power failure situation.

Power Management Setup

The Power Management Setup allows you to save energy of your system effectively.

CMOS Setup Utility – Copyright © 1984-2001 Award Software
Power Management Setup

ACPI Function	Enabled	ITEM HELP
Power Management	User Define	Menu Level
Video Off Method	DPMS	
Video Off In Suspend	Yes	
Suspend Type	Stop Grant	
Modem Use IRQ	3	
Suspend Mode	Disabled	
HDD Power Down	Disabled	
Soft-Off by PWR-BTTN	Instant-Off	
CPU THRM-Throttling	50%	
Power On by Ring	Disabled	
Resume by Alarm	Disabled	
Date (of Month) Alarm	0	
Time (hh:mm:ss) Alarm	0 : 0 : 0	
** Reload Global Timer Events **		
Primary IDE 0	Disabled	
Primary IDE 1	Disabled	
Secondary IDE 0	Disabled	
Secondary IDE 1	Disabled	
FDD, COM, LPT Port	Disabled	
PCI PIRQ[A-D] #	Disabled	

ACPI Function

Enable this function to support ACPI (Advance Configuration and Power Interface).

Power Management

This field allows you to select the type of power saving management modes. There are four selections for Power Management.

Min. Power Saving

Minimum power management

Max. Power Saving

Maximum power management.

User Define

Each of the ranges is from 1 min. to 1hr.
Except for HDD Power Down which ranges from 1 min. to 15 min.

Video Off Method

This field defines the Video Off features. There are three options.

V/H SYNC + Blank	Default setting, blank the screen and turn off vertical and horizontal scanning.
DPMS	Allows BIOS to control the video display.
Blank Screen	Writes blanks to the video buffer.

Video Off In Suspend

When enabled, the video is off in suspend mode. The default is *Yes*.

Suspend Type

The default setting for the Suspend Type field is *Stop Grant*.

Modem Use IRQ

This field sets the IRQ used by the Modem. By default, the setting is *3*.

Suspend Mode

When enabled, and after the set time of system inactivity, all devices except the CPU will be shut off.

HDD Power Down

When enabled, and after the set time of system inactivity, the hard disk drive will be powered down while all other devices remain active.

Soft-Off by PWRBTN

This field defines the power-off mode when using an ATX power supply. The *Instant Off* mode allows powering off immediately upon pressing the power button. In the *Delay 4 Sec* mode, the system powers off when the power button is pressed for more than four seconds or enters the suspend mode when pressed for less than 4 seconds.

CPU THRM-Throttling

When the system enters Doze mode, the CPU clock runs only part of the time. You may select the percent of time that the clock runs.

Power On by Ring

This field enables or disables the power on of the system through the modem connected to the serial port or LAN.

Resume by Alarm

This field enables or disables the resumption of the system operation. When enabled, the user is allowed to set the *Date* and *Time*.

Reload Global Timer Events

The HDD, FDD, COM, LPT Ports, and PCI PIRQ are I/O events which can prevent the system from entering a power saving mode or can awaken the system from such a mode. When an I/O device wants to gain the attention of the operating system, it signals this by causing an IRQ to occur. When the operating system is ready to respond to the request, it interrupts itself and performs the service.

PNP/PCI Configurations

This option configures the PCI bus system. All PCI bus systems on the system use INT#, thus all installed PCI cards must be set to this value.

CMOS Setup Utility – Copyright © 1984-2001 Award Software
PnP/PCI Configurations

Reset Configuration Data	Disabled	ITEM HELP
Resources Controlled By	Auto (ESCD)	Menu Level
IRQ Resources	Press Enter	Default is Disabled.
DMA Resources	Press Enter	Select Enabled to reset Extended System Configuration Data (ESCD) when you exit Setup if you have installed a new add-on and the system reconfiguration has caused such a serious conflict that the OS cannot boot
PCI/VGA Palette Snoop	Disabled	

Reset Configuration Data

This field allows you to determine whether to reset the configuration data or not. The default value is *Disabled*.

Resources Controlled by

This PnP BIOS can configure all of the boot and compatible devices automatically with the use of a use a PnP operating system such as Windows 95.

PCI/VGA Palette Snoop

Some non-standard VGA display cards may not show colors properly. This field allows you to set whether or not MPEG ISA/VESA VGA cards can work with PCI/VGA. When this field is enabled, a PCI/VGA can work with an MPEG ISA/VESA VGA card. When this field is disabled, a PCI/VGA cannot work with an MPEG ISA/VESA card.

PC Health Status

This section shows the parameters in determining the PC Health Status. These parameters include temperatures, fan speeds and voltages.

CMOS Setup Utility – Copyright © 1984-2001 Award Software
PC Health Status

		ITEM HELP
CPU Warning Temperature	Disabled	
Current CPU Temp.	32°C/89°F	
Current System Temp.	39°C/102°F	
CPU FAN Speed	4166 RPM	
Chassis FAN1 Speed	0 RPM	
Chassis FAN2 Speed	0 RPM	
Vcore (V)	1.63V	
VCC3(V)	3.37V	
+5(V)	5.05V	
+12(V)	12.09V	
-12(V)	(-)12.03V	
VBAT(V)	3.21V	
5VSB(V)	5.05V	
Shutdown Temperature	Disabled	
CPU Fan Failure Warning	Disabled	
Sys. Fan Failure Warning	Disabled	
Aux. Fan Failure Warning	Disabled	

CPU Warning Temperature

This field allows the user to set the temperature so that when the temperature is reached, the systems sounds a warning. This function can help prevent damage to the system that is caused by overheating.

Temperatures/Fan Speeds/Voltages

These fields are the parameters of the hardware monitoring function feature of the motherboard. The values are read-only values as monitored by the system and show the PC health status.

Shutdown Temperature

This field allows the user to set the temperature by which the system automatically shuts down once the threshold temperature is reached. This function can help prevent damage to the system that is caused by overheating.

Fan Failure Warning

This field allows the user to set the Fan warning so that when the CPU(Fan3)/Sys.(Fan1)/Aux.(Fan2) is stop runing, the system sounds a warning, this function can help user to prevent damage the system that is caused by Fan stop running.

Frequency/Voltage Control

This section shows the user how to configure the processor frequency.

CMOS Setup Utility – Copyright © 1984-2001 Award Software
Frequency/Voltage Control

Auto Detect PCI Clk	Disabled	ITEM HELP
Spread Spectrum Modulated	Disabled	Menu Level

Auto Detect PCI Clk

This field enables or disables the auto detection of the PCI clock.

Spread Spectrum

This field sets the value of the spread spectrum. The default setting is *Disabled*. This field is for CE testing use only.

Load Fail-Safe Defaults

This option allows you to load the troubleshooting default values permanently stored in the BIOS ROM. These default settings are non-optimal and disable all high-performance features.

Load Setup Defaults

This option allows you to load the default values to your system configuration. These default settings are optimal and enable all high performance features.

Set Supervisor/User Password

These two options set the system password. Supervisor Password sets a password that will be used to protect the system and Setup utility. User Password sets a password that will be used exclusively on the system. To specify a password, highlight the type you want and press <Enter>. The Enter Password: message prompts on the screen. Type the password, up to eight characters in length, and press <Enter>. The system confirms your password by asking you to type it again. After setting a password, the screen automatically returns to the main screen.

To disable a password, just press the <Enter> key when you are prompted to enter the password. A message will confirm the password to be disabled. Once the password is disabled, the system will boot and you can enter Setup freely.

Save & Exit Setup

This option allows you to determine whether or not to accept the modifications. If you type “Y”, you will quit the setup utility and save all changes into the CMOS memory. If you type “N”, you will return to Setup utility.

Exit Without Saving

Select this option to exit the Setup utility without saving the changes you have made in this session. Typing “Y” will quit the Setup utility without saving the modifications. Typing “N” will return you to Setup utility.

Drivers Installation

This section describes the installation procedures for software and drivers under the Windows 98, Windows NT 4.0 and Windows 2000. The software and drivers are included with the motherboard. If you find the items missing, please contact the vendor where you made the purchase. The contents of this section include the following:

Intel Chipset Software Installation Utility.....	53
Intel 845GV Chipset Graphics Driver Installation	56
Realtek AC97 Codec Audio Driver Installation.....	59
Realtek RTL8100 LAN Drivers Installation.....	61

IMPORTANT NOTE:

After installing your Windows operating system (Windows 98/98SE/ME/2000/XP), you must install first the Intel Chipset Software Installation Utility before proceeding with the drivers installation.

Intel Chipset Software Installation Utility

The Intel Chipset Software Installation Utility, to be installed first before the software drivers, will enable Plug & Play INF support for Intel chipset components. Follow the instructions below to complete the installation under Windows 98/98SE/ME/2000/XP.

1. Insert the CD that comes with the motherboard and the screen below would appear. Click Intel Chipsets and then Intel 845GV Chipset Drivers.



2. Click Intel Chipset Software Installation Utility.



3. When the Welcome screen appears, click Next to continue.

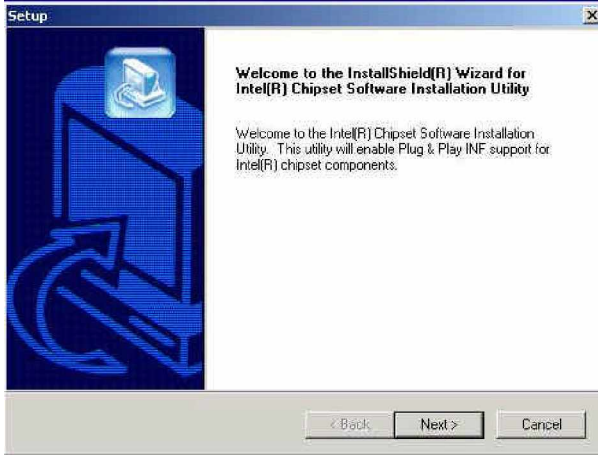

4. Click Yes to accept the software license agreement and proceed with the installation process.

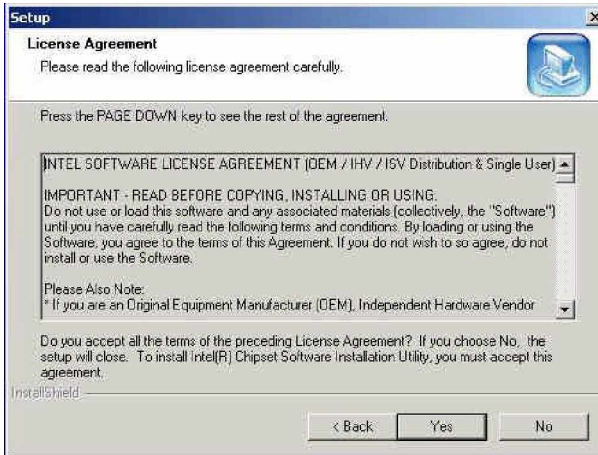

5. On Readme Information screen, click Next to continue the installation.

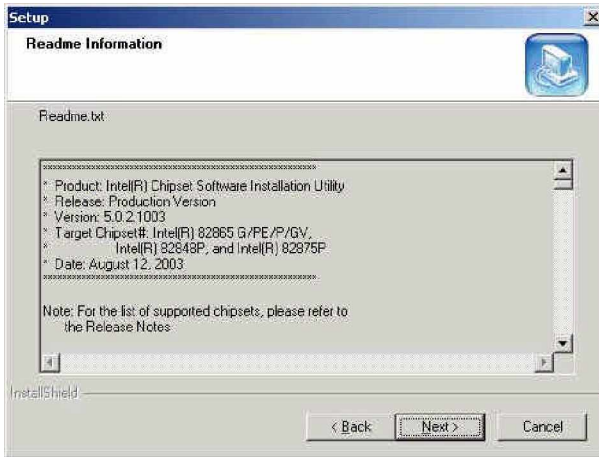

6. The Setup process is now complete. Click Finish to restart the computer and for changes to take effect. When the computer has restarted, the system will be able to find some devices. Restart your computer when prompted.



Intel 845GV Chipset Graphics Driver Installation

Follow the steps below to install the Intel 845GV graphics driver under Windows 98/98SE/ME/2000/XP/NT 4.0.

1. Insert the CD that comes with the motherboard. Click Intel Chipsets on the left side of the screen. Then select, Intel 845GV Chipset Drivers, then Intel 845G Family Graphics Driver.



2. Click Next to continue.

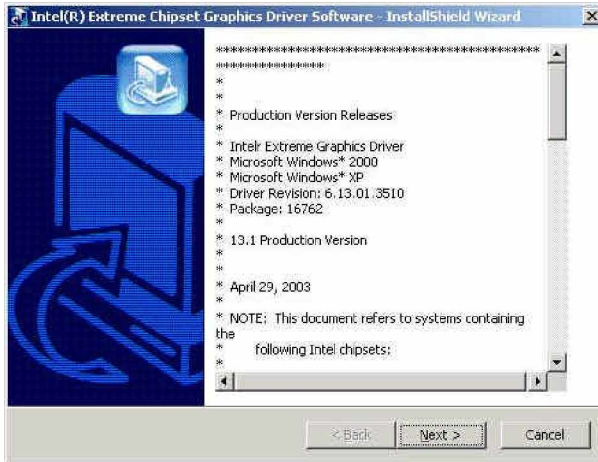

3. When the Welcome screen appears, click Next to continue.

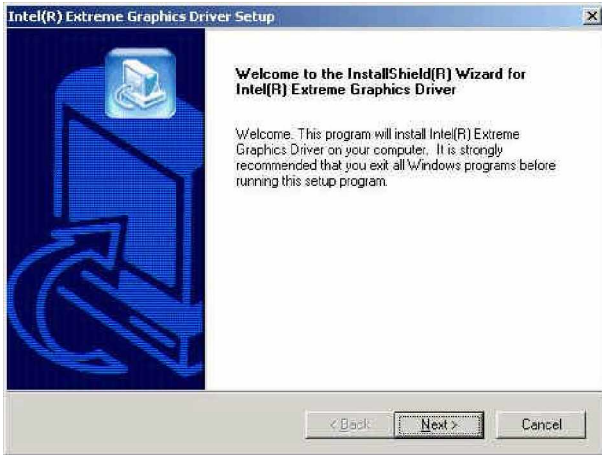

3. Click Yes to accept the software license agreement and proceed with the installation process.

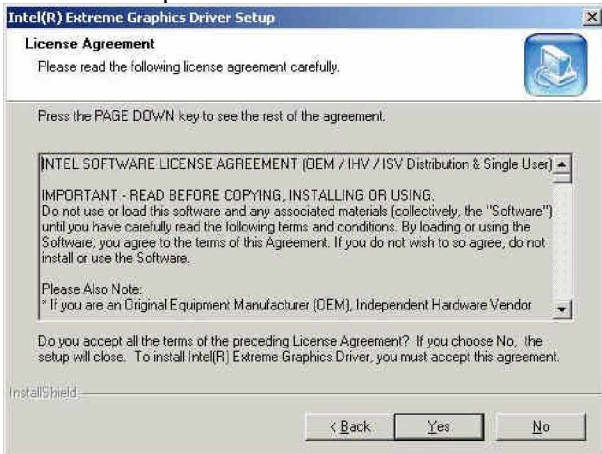

4. The Setup process is now complete. Click Finish to restart the computer and for changes to take effect. Restart your computer when prompted.

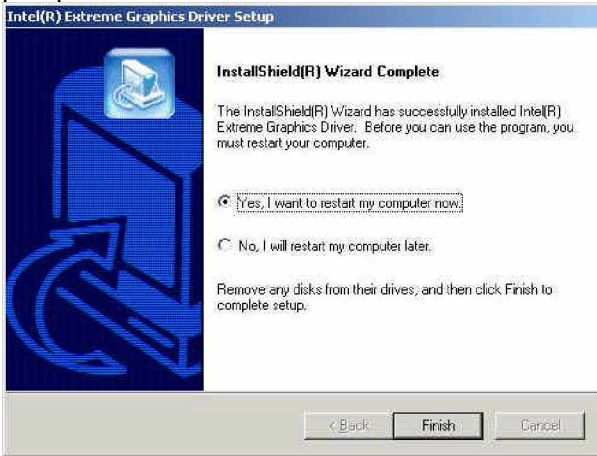

AC97 Codec Audio Driver Installation

Follow the steps below to install the AC97 Codec Audio Drivers.

1. Insert the CD that comes with the CPU card and the screen below would appear. Click Intel Chipsets. Click AC97 Codec Audio Drivers to start the drivers installation.

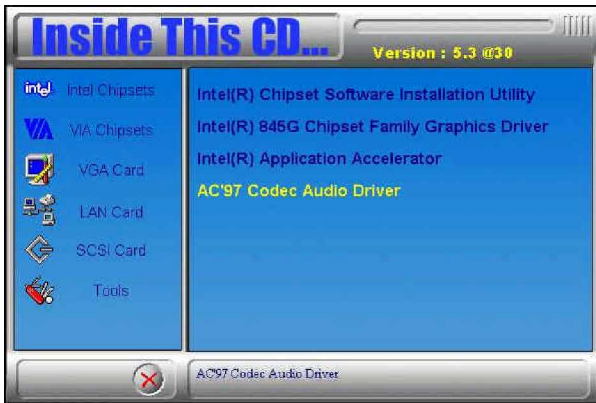

2. Click Yes to continue the installation.



3. Click Finish to restart the computer and for changes to take effect. .

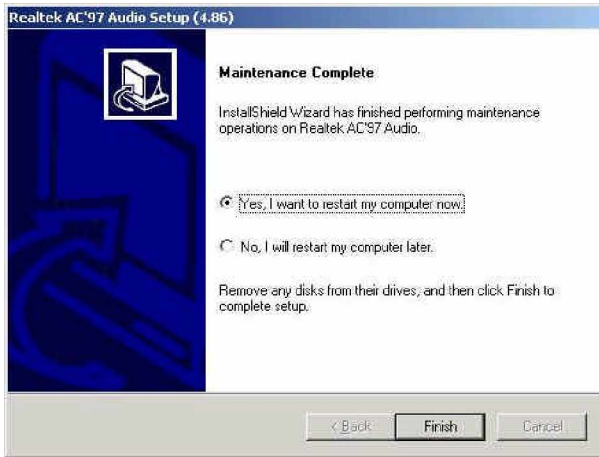

Realtek RTL8139 LAN Drivers Installation

Follow the steps below to start installing the Realtek LAN drivers.

1. Insert the CD that comes with the CPU. In the initial screen, click on LAN Card on the left side. Then, select Realtek RTL8139x LAN Drivers.



2. When the Welcome screen appears, click Next to start the drivers installation.

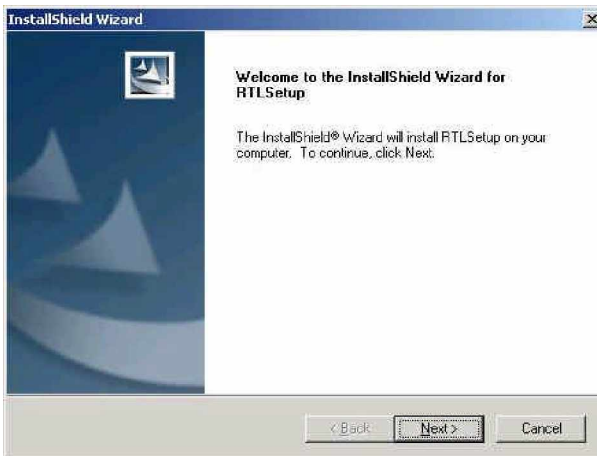

3. Click Finish to complete the setup and for changes to take effect.

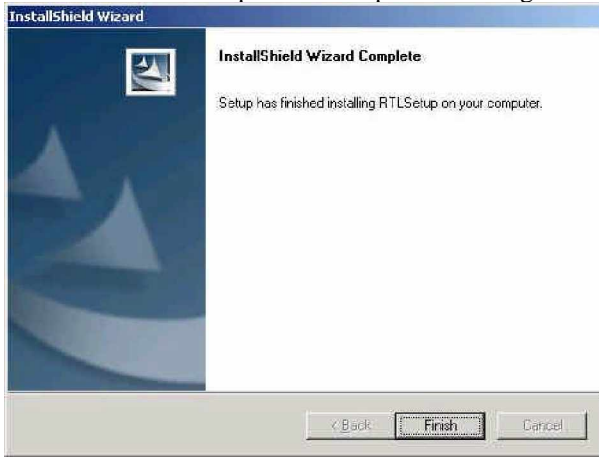

This page is intentionally left blank.

Appendix

A. I/O Port Address Map

Each peripheral device in the system is assigned a set of I/O port addresses which also becomes the identity of the device. The following table lists the I/O port addresses used.

Address	Device Description
000h - 01Fh	DMA Controller #1
020h - 03Fh	Interrupt Controller #1
040h - 05Fh	Timer
060h - 06Fh	Keyboard Controller
070h - 07Fh	Real Time Clock, NMI
080h - 09Fh	DMA Page Register
0A0h - 0BFh	Interrupt Controller #2
0C0h - 0DFh	DMA Controller #2
0F0h	Clear Math Coprocessor Busy Signal
0F1h	Reset Math Coprocessor
1F0h - 1F7h	IDE Interface
278 - 27F	Parallel Port #2(LPT2)
2F8h - 2FFh	Serial Port #2(COM2)
2B0 - 2DF	Graphics adapter Controller
378h - 3FFh	Parallel Port #1(LPT1)
360 - 36F	Network Ports
3B0 - 3BF	Monochrome & Printer adapter
3C0 - 3CF	EGA adapter
3D0 - 3DF	CGA adapter
3F0h - 3F7h	Floppy Disk Controller
3F8h - 3FFh	Serial Port #1(COM1)

B. Interrupt Request Lines (IRQ)

Peripheral devices use interrupt request lines to notify CPU for the service required. The following table shows the IRQ used by the devices on board.

Level	Function
IRQ0	System Timer Output
IRQ1	Keyboard
IRQ2	Interrupt Cascade
IRQ3	Serial Port #2
IRQ4	Serial Port #1
IRQ5	Reserved
IRQ6	Floppy Disk Controller
IRQ7	Parallel Port #1
IRQ8	Real Time Clock
IRQ9	Reserved
IRQ10	Reserved
IRQ11	Reserved
IRQ12	PS/2 Mouse
IRQ13	80287
IRQ14	Primary IDE
IRQ15	Secondary IDE

Any advice or comments about our products and service, or anything we can help you with please don't hesitate to contact with us. We will do our best to support you for your products, projects and business

Global American Inc.

Address: 17 Hampshire Drive
Hudson, NH 03051

TEL: Toll Free (U.S. Only) 800-833-8999
(603) 886-3900

FAX: (603) 886-4545

Website: <http://www.globalamericaninc.com>

E-Mail: salesinfo@globalamericaninc.com

