



User's Manual

2804090

Copyright

Copyright 2006. All rights reserved. This document is copyrighted and all rights are reserved. The information in this document is subject to change without prior notice to make improvements to the products.

This document contains proprietary information and protected by copyright. No part of this document may be reproduced, copied, or translated in any form or any means without prior written permission of the manufacturer.

All trademarks and/or registered trademarks contains in this document are property of their respective owners.

Disclaimer

The company shall not be liable for any incidental or consequential damages resulting from the performance or use of this product.

The company does not issue a warranty of any kind, express or implied, including without limitation implied warranties of merchantability or fitness for a particular purpose.

The company has the right to revise the manual or include changes in the specifications of the product described within it at any time without notice and without obligation to notify any person of such revision or changes.

Trademark

All trademarks are the property of their respective holders.

Packing List

Please check the package before you starting setup the system

Hardware:

2804090 series motherboard x 1

Cable Kit:

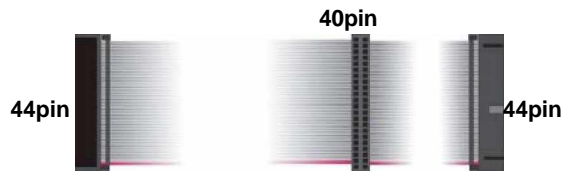

44-pin ATA33 IDE Cable x 1



COM port Cable x1

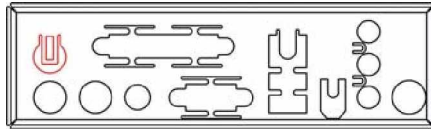

I/O Shield Cable x 1

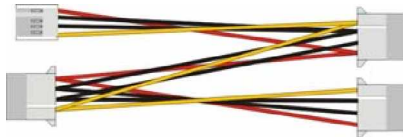

Power Cable x 1



Floppy Cable x 1

Printed Matters:

User's Manual x 1

Driver CD x 1

Index

Chapter 1 <Introduction>	7
1.1 <Product Overview>.....	7
1.2 <Product Specification>	8
1.3 <Mechanical Drawing>.....	10
1.4 <Block Diagram>.....	11
Chapter 2 Hardware Setup	12
2.1 <Connector Location>.....	12
2.2 <Jumper Reference>.....	13
2.3 <Connector Reference>.....	14
2.3.1 <Internal Connector>.....	14
2.3.2 <External Connector>.....	14
2.4 <CPU and Memory Setup>	15
2.4.1 < CPU Setup>	15
2.4.2 <Memory Setup>	15
2.5 <CMOS Setup>	16
2.6 <Enhanced IDE & CF Interface>	17
2.7 <Floppy Port>	18
2.8 <LAN Interface>	19
2.9 <Onboard Display Interface>	19
2.9.1 <Analog VGA Interface>.....	19
2.9.2 < Digital Display >.....	20
2.10 <Onboard Audio Interface>	26
2.11 <USB2.0 Interface>	27
2.12 <GPIO Interface>	29
2.13 <Serial Port Jumper Setting>	30
2.14 <Power and Fan Connector>	32
2.14.1 <Power Input>.....	32

2.14.2 <Power Output>.....	32
2.14.3 <Fan Connector>.....	33
2.15 <Indicator and Switch>.....	34
Chapter 3 <BIOS Setup>.....	37
Appendix A <I/O Port Pin Assignment>.....	38
A.1 <IDE Port>.....	38
A.2 <Floppy Port>.....	40
A.3 <Serial Port>.....	40
A.4 < CRT Port >.....	41
A.5 <LAN Port>.....	41
A.6 <USB Port>.....	41
A.6 <USB Port>.....	41
A.7 <PS/2 Keyboard & MousePort>.....	42
A.8 <LPT Port>.....	42
Appendix B <Flash BIOS>.....	43
B.1 BIOS Auto Flash Tool.....	43
B.2 Flash Method.....	43
Appendix C <System Resources>.....	45
C.1 I/O Port Address Map	45
C.2 Memory Address Map	47
C.3 System IRQ Resources.....	48
Appendix D <WatchDog Timer Setting>.....	49
Contact Information.....	50

(The Page is Left For Blank)

Chapter 1 <Introduction>

1.1 <Product Overview>

2804090 is the Mini-ITX motherboard with AMD Geode LX800 platform, with onboard VGA, AC97 audio, Giga LAN interface. Based on the AMD Geode LX800 processor, the board provides many advanced features for reduced power consumption, fanless design and high cost/price rate of production.

Low Power Consumption

Based on the AMD Geode LX800@500MHz processor onboard, it only takes up to 3.8W at maximum powering, and is completely suitable for fanless design. Without any cooling fan onboard, it can avoid the heat problem when the cooler failed in accident.

Onboard TFT/LVDS LCD interface

Based on the AMD Geode LX800@500Mhz of integrated graphics, the board provides onboard graphics with up to 256 MB of frame buffer, 18-bit/24-bit LVDS and 24-bit TFT interfaces.

Embedded Component

Due to the low profile design, the board provides CF card socket for flash disk with porting embedded OS and up to DDR SDRAM.

Single Voltage Input

The board only requires DC 8~24V or standard 20-pin ATX power supply input; user's can easily connect the board with an adapter without the huge power supply.

1.2 <Product Specification>

General Specification

Form Factor	Mini -ITX motherboard
CPU	Embedded AMD Geode LX800 500MHz Fanless with heat sink only
Memory	One 184-pin DDR DIMM socket support up to 1GB DDR SDRAM Optional on board 256M DDR SDRAM Unbuffered, none-ECC memory supported only
Chipset	AMD LX800 and CS5536
BIOS	Phoenix-Award v6.00PG 4Mb PnP flash BIOS
Green Function	Power saving mode includes doze, standby and suspend modes. ACPI version 1.0 and APM version 1.2 compliant
Watchdog Timer	System reset programmable watchdog timer with 1 ~ 255 sec./min. of timeout value
Real Time Clock	AMD CS5536 built-in RTC with lithium battery
Enhanced IDE	Ultra DMA33 IDE interface supports up to 2 ATAPI devices One 44-pin IDE port onboard One Compact Flash Type II socket on solder side

Multi-I/O Port

Chipset	Winbond W83627HG-AW
Serial Port	One RS-232 and one RS232/422/485 serial ports
USB Port	Four Hi-Speed USB 2.0 ports with 480Mbps of transfer rate
Parallel Port	One D-sub 25pin LPT Port
Floppy Port	One slim type Floppy port
IrDA Port	One IrDA compliant Infrared interface supports SIR
K/B & Mouse	External PS/2 keyboard and mouse ports on rear I/O panel
GPIO	One 12-pin Digital I/O connector with 8-bit programmable I/O interface

VGA Display Interface

Chipset	AMD Geode LX800 built-in VGA controller with 2D Graphic
Frame Buffer	Up to 256MB shared with system memory
Display Type	Supports CRT, 24-bit TFT LCD & 18/24-bit single channel LVDS LCD
Connector	External DB15 female connector on rear I/O panel Onboard 40-pin TFT connector Onboard 40-pin LVDS connector

Ethernet Interface

Controller	1 x Realtek RTL8110S-32 Gigabit Ethernet controller
Type	Triple speed 10/100/1000Base-T Auto-switching Fast Ethernet

	Full duplex, IEEE802.3U compliant
Connector	One External RJ45 connector with LED on rear I/O panel

Audio Interface

Chipset	Realtek ® ALC203 AC97 Audio compliance
Interface	2 channels sound output
Connector	External Audio phone jack for Line-out, Line-in, MIC-in. Onboard audio connector with pin header Onboard CD-IN connector

Expansive Interface

PCI	One Mini-PCI socket for TYPE III . Bus master. 2nd Bus master is shared with Mini-PCI. One PCI slot with riser card to support 2 PCI Power supply: +3.3V, +5V
-----	---

Power and Environment

Power Requirement	8~24V DC input or Standard 20-pin ATX power supply
Dimension	170 (L) x 170 (H) mm
Temperature	Operating within 0 ~ 60 (32 ~ 140) Storage within -20 ~ 85 (-4 ~ 185)

Ordering Code

2804090A	AMD LX800 processor Mini-ITX with onboard VGA, GigaLAN, LPT, RS232, USB2.0, Audio, IEEE1394, LCD and DDR DIMM
2804090B	Same as above but with 256M DDR SDRAM on board

1.3 <Mechanical Drawing>

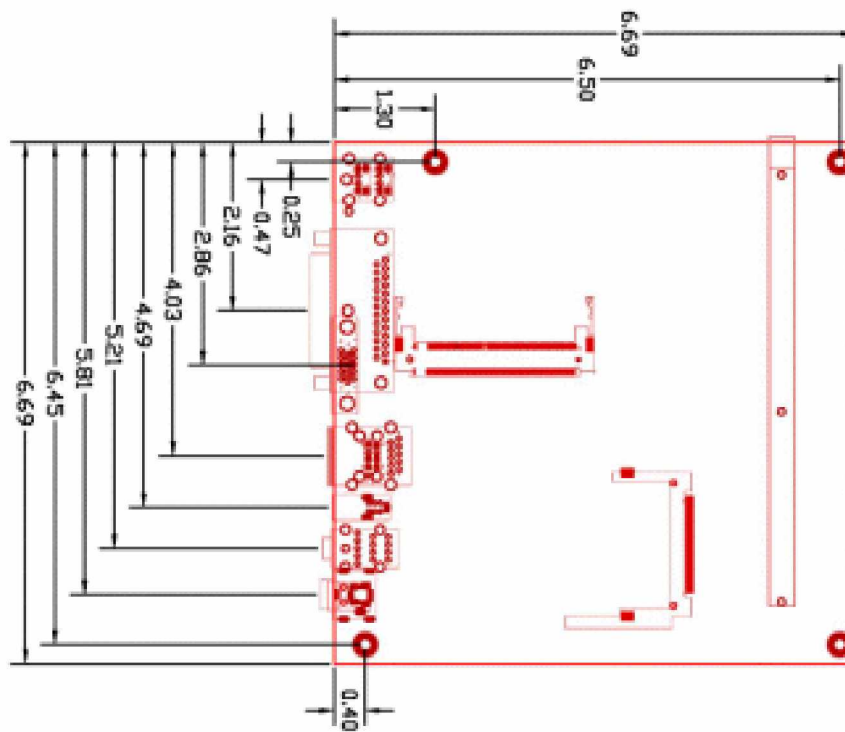

1.4 <Block Diagram>

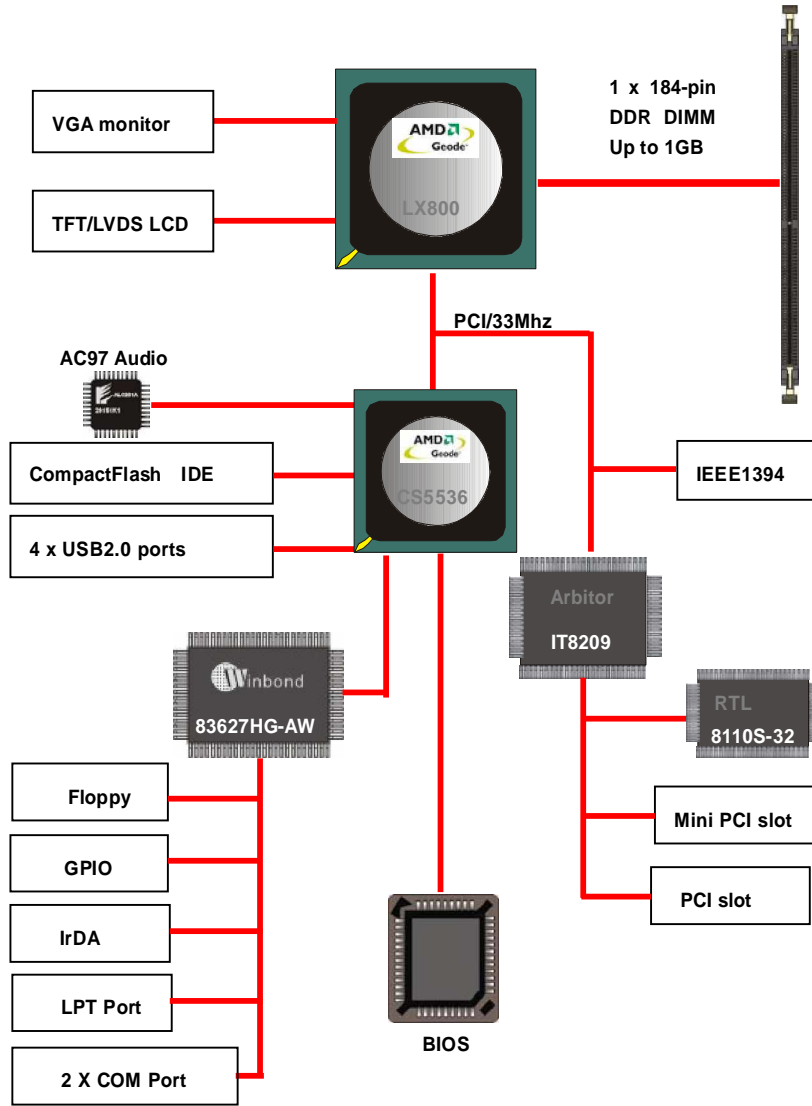

Chapter 2 <Hardware Setup>

2.1 <Connector Location>

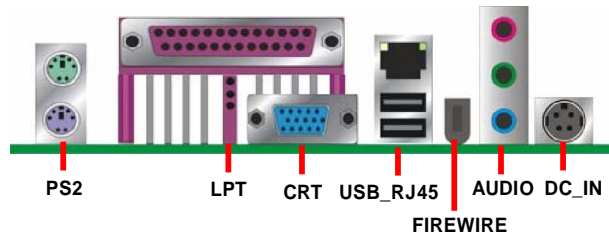
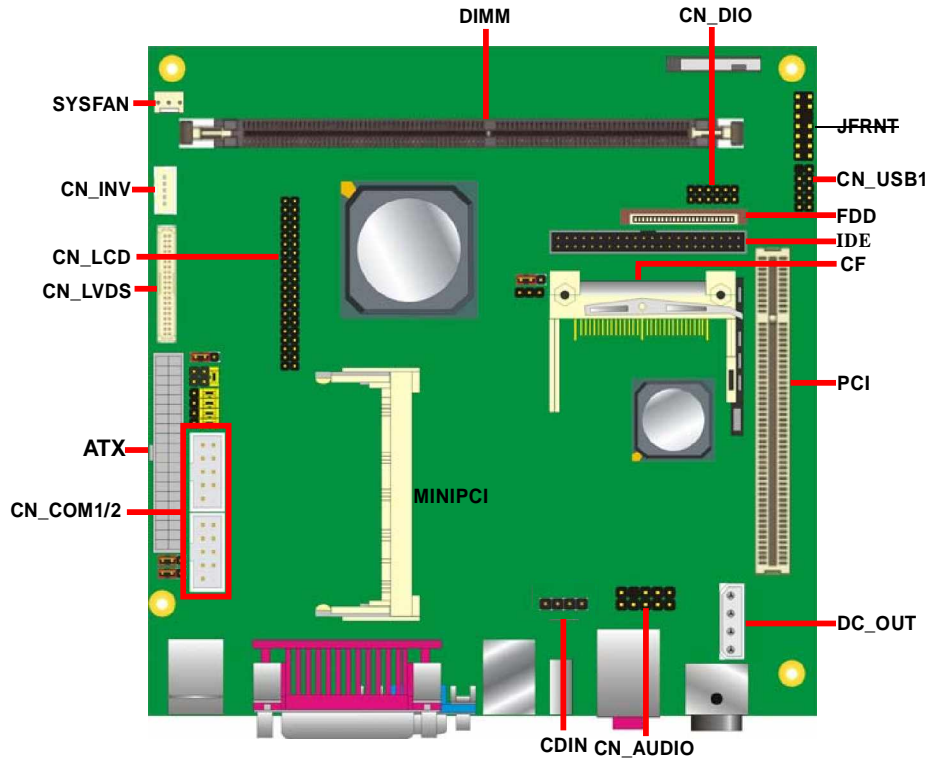

2.2 <Jumper Reference>

Jumper	Function
JRTC	CMOS Operating/Clear Setting
JV1/2	Setting COM Port Voltage
JVLCD	LCD Panel Voltage Setting
JCSEL1/2	COM2 RS-232/422/485 Mode Selection
JAT	Select ATX or AT power on function

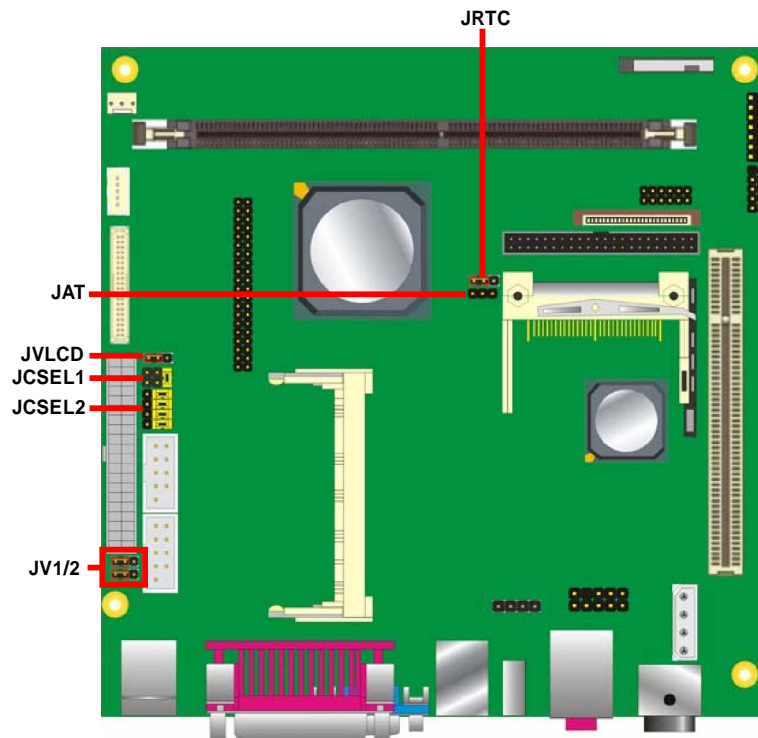

2.3 <Connector Reference>

2.3.1 <Internal Connector>

Connector	Function	Remark
DIMM	184 -pin DDR SDRAM DIMM slot	Standard
IDE	44-pin primary IDE connector	Slim
FDD	26-pin slim type floppy connector	Slim
ATX	20-pin power supply connector	Standard
CF	Compact Flash Type II socket	Standard
DC_OUT	4-pin power output connector	Standard
CDIN	4-pin CD-ROM audio input connector	Standard
CN_DIO	6 x 2-pin digital I/O connector	Standard
CN_USB1	5 x 2-pin USB connector	Standard
SYSFAN	3-pin system cooler fan connector	Standard
CN_COM1/2	5 x 2-pin com connector	Standard
CN_AUDIO	5 x 2-pin audio connector	Standard
CN_LVDS	20 x 2-pin LVDS connector	Standard
CN_INV	5-pin LCD inverter connector	Standard
CN_LCD	20 x 2-pin LCD connector	Standard
PCI	Slim 32bit PCI slot	Slim
MINIPCI	Mini-PCI socket	Standard
JFRNT	14-pin switch/indicator connector	Standard
JAT	3-pin power connector	Standard

2.3.2 <External Connector>

Connector	Function	Remark
PS2	PS/2 Keyboard/Mouse connector	Standard
LPT	25-pin D-sub LPT port	Standard
USB_RJ45	Dual USB and one RJ45 LAN connector	Standard
CRT	DB15 VGA connector	Standard
FIREWIRE	One IEEE1394 connector	Standard
AUDIO	Audio connector	Standard
DC_IN	DC 12V input connector	Standard

2.4 <CPU and Memory Setup>

2.4.1 <CPU Setup>

The board integrates AMD Geode LX800 500MHz processor with special design for power appliance. It requires only 3.8W power consumption at most, and is totally designed for fanless system.

2.4.2 <Memory Setup>

The board supports one 184-pin DDR266/333 SDRAM up to 1GB of capacity, and supports non ECC unbuffered memory modules.

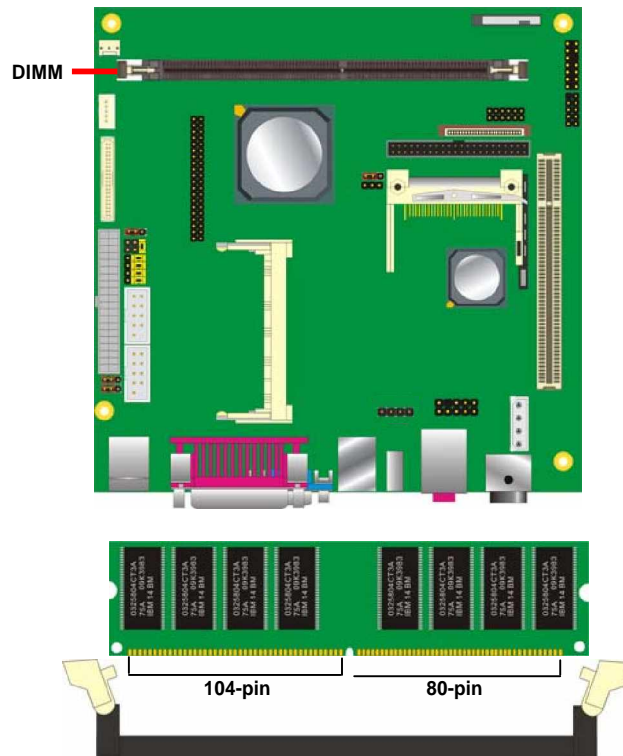

Please check the pin number to match the socket side well before installing memory module.

2.5 <CMOS Setup>

The board's data of CMOS can be setting in BIOS. If the board refuses to boot due to inappropriate CMOS settings, here is how to proceed to clear (reset) the CMOS to its default values.

Jumper: JRTC

Type: Onboard 3-pin jumper

JRTC	Mode
1-2	Clear CMOS
2-3	Normal Operation
Default setting	

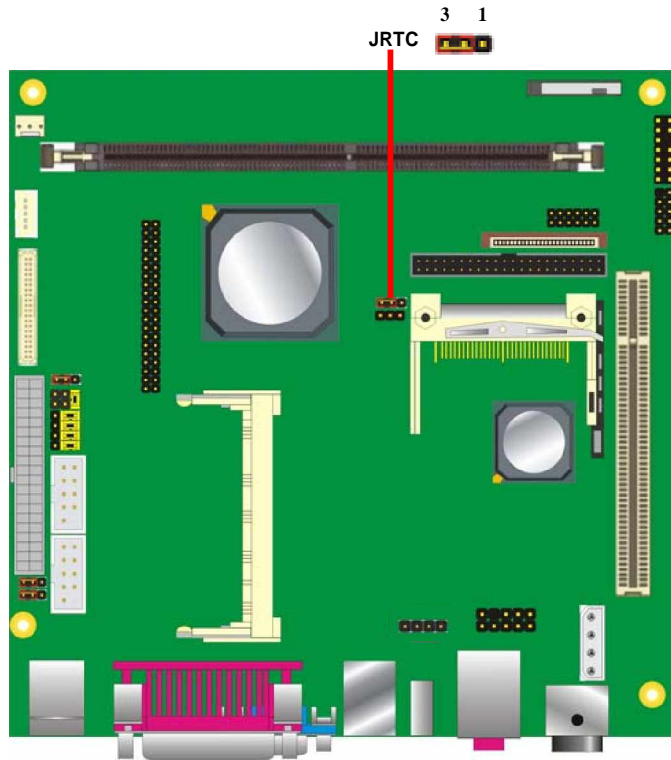

2.6 <Enhanced IDE & CF Interface>

The board has one Ultra DMA33 IDE interface to support up to 2 ATAPI devices, and one Compact Flash Type II socket on the solder side.

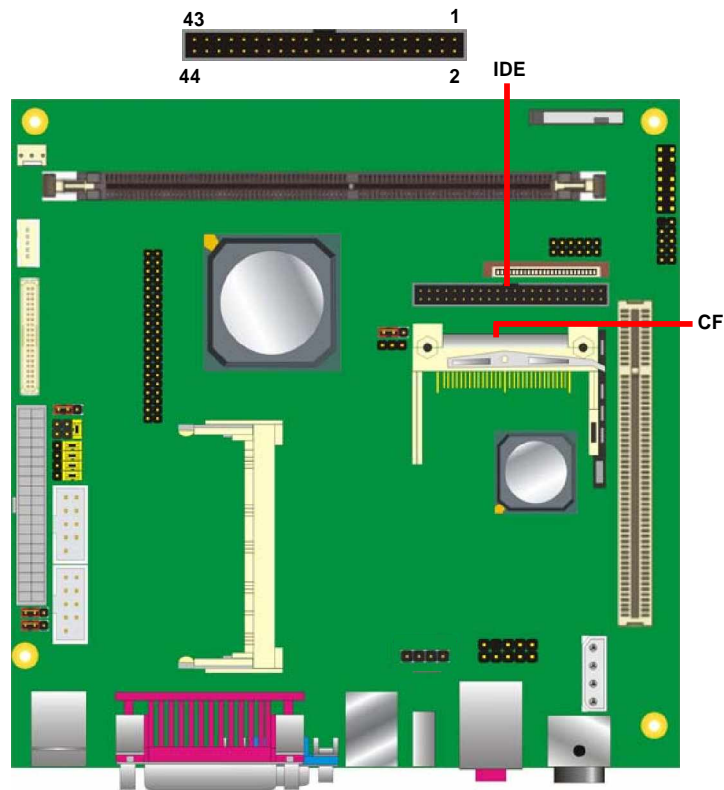

2.7 <Floppy Port>

The board provides a slim type floppy port; please use the 26-pin FPC cable in the package to connect the floppy device.

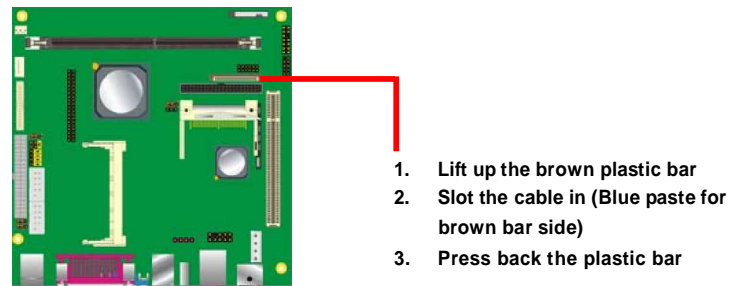
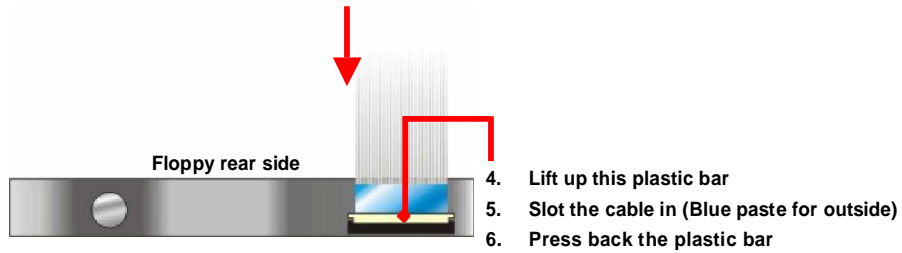
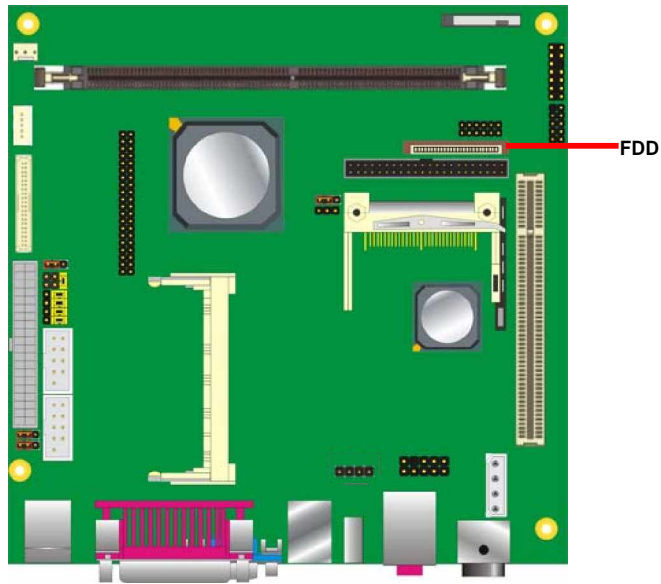

2.8 <LAN Interface>

The board integrates with one Realtek RTL8110S-32 Gigabit Ethernet controller. The Realtek RTL8110S-32 supports triple speed of 10/100/1000Base-T, with IEEE802.3 compliance and Wake-On-LAN supported.



2.9 <Onboard Display Interface>

The board integrates AMD Geode LX800 processor with built-in 2D video engine, to provide onboard DB15 VGA connector, 24-bit TFT and 18-bit/24-bit LVDS interface. The built-in 2D video engine supports following specified functions:

- High-performance 2D graphics controller
- Alpha BLT
- Integrated dot clock PLL

2.9.1 <Analog VGA Interface>

Please connect your CRT or LCD monitor with DB15 male connector to the onboard DB15 female connector on rear I/O port.

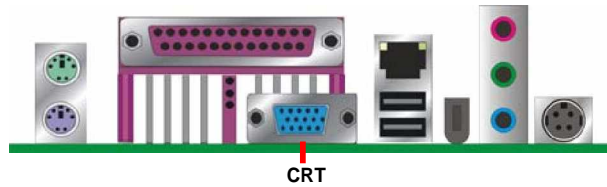

2.9.2 <Digital Display>

The board provides one 40-pin LVDS connector for 18-bit single channel panel, supports up to 1024 x 768 of resolution, with one LCD backlight inverter connector and one jumper for panel voltage setting

Connector: **CN_INV**

Connector model: **JST B5B-XH-A**

Type: 5-pin LVDS Power Header

Pin	Description
1	+12V
2	GND
3	GND
4	GND
5	ENABKL

Connector: **JVLCD**

Type: 3-pin Power select Header

Pin	Description
1	VCC(5V)
2	LCDVCC
3	VCC3(3.3V)

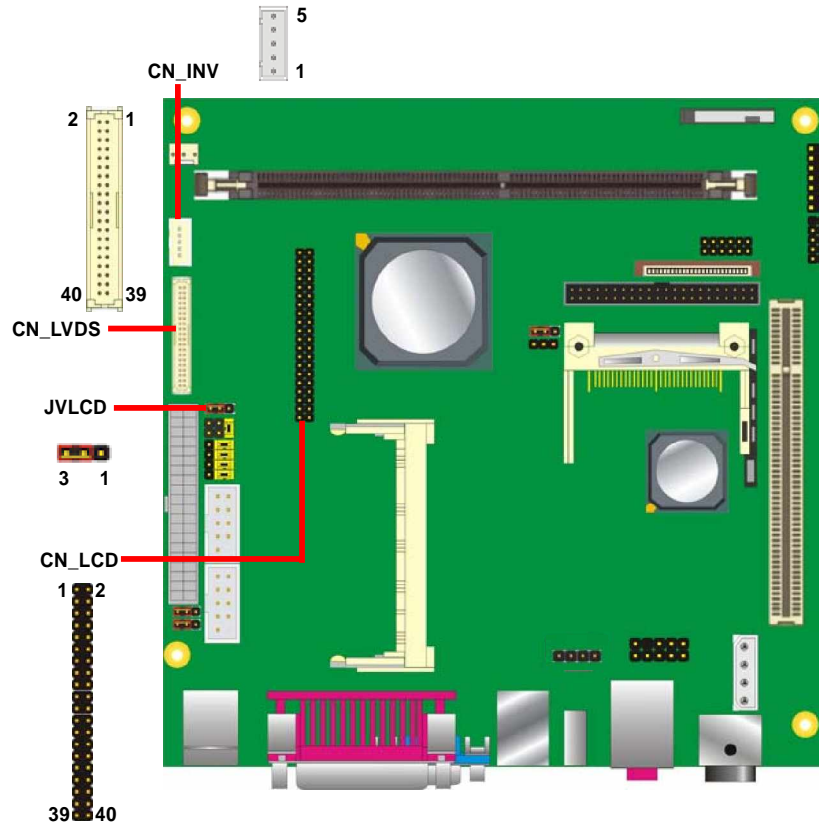

Connector: CN_LVDS (for 24bit Single channel LVDS panel)

Type: 40-pin header (40 x 2 pitch 2.0 mm)

Connector model: Hirose DF13- 40DP-1.25V

Pin	Signal (18-bit)	Pin	Signal (24-bit)
2	LCDVCC	1	LCDVCC
4	GND	3	GND
6	NC	5	TA2-
8	NC	7	TA2+
10	GND	9	GND
12	NC	11	TB2-
14	NC	13	TB2+
16	GND	15	GND
18	NC	17	TC2-
20	NC	19	TC2+
22	GND	21	GND
24	NC	23	TD2-
26	NC	25	TD2+
28	GND	27	GND
30	NC	29	TCLK2-
32	NC	31	TCLK2+
34	GND	33	GND
36	N/C	35	N/C
38	N/C	37	N/C
40	N/C	39	N/C

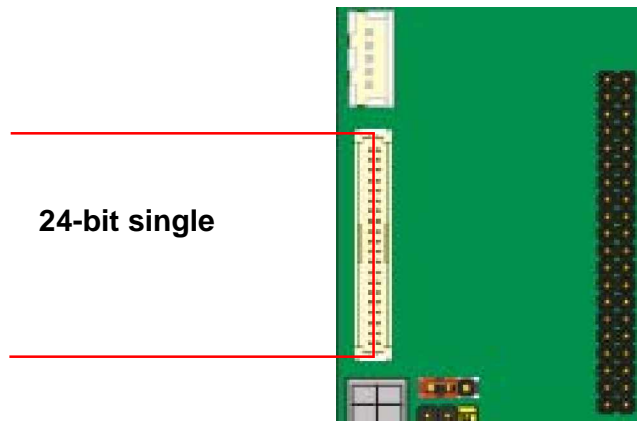

Connector: **CN_LVDS (for 18bit Single channel LVDS panel)**

Type: 40-pin header (40 x 2 pitch 2.0 mm)

Connector model: **Hirose DF13-40DP-1.25V**

Pin	Signal (18-bit)	Pin	Signal (24-bit)
2	LCDVCC	1	LCDVCC
4	GND	3	GND
6	TA1-	5	N/C
8	TA1+	7	N/C
10	GND	9	GND
12	TB1-	11	N/C
14	TB1+	13	N/C
16	GND	15	GND
18	TC1-	17	N/C
20	TC1+	19	N/C
22	GND	21	GND
24	TCLK1-	23	N/C
26	TCLK1+	25	N/C
28	GND	27	GND
30	N/C	29	N/C
32	N/C	31	N/C
34	GND	33	GND
36	N/C	35	N/C
38	N/C	37	N/C
40	N/C	39	N/C

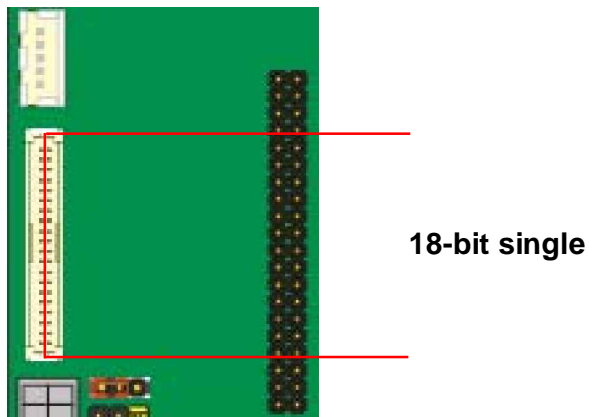

Connector: **CN_LCD**

Type: onboard 2 x 20-pin header with housing, pitch=2.0mm

Pin	Signal	Pin	Signal
1	ENAVDD	2	ENAVEE
3	GND	4	GND
5	VLCD	6	VLCD
7	GND	8	GND
9	GFP0	10	GFP1
11	GFP2	12	GFP3
13	GFP4	14	GFP5
15	GFP6	16	GFP7
17	GFP8	18	GFP9
19	GFP10	20	GFP11
21	GFP12	22	GFP13
23	GFP14	24	GFP15
25	GFP16	26	GFP17
27	GFP18	28	GFP19
29	GFP20	30	GFP21
31	GFP22	32	GFP23
33	N/C	34	N/C
35	FPCLK	36	VSYNC
37	RM	38	HSYNC
39	GND	40	GND

To setup the LCD, you need the component below:

1. A panel with LVDS interfaces.
2. An inverter for panel's backlight power.
3. A LCD cable and an inverter cable.

For the cables, please follow the pin assignment of the connector to make a cable, because every panel has its own pin assignment, so we do not provide a standard cable; please find a local cable manufacture to make cables.

LCD Installation Guide:

1. Preparing the **2804090**, LCD panel and the **backlight inverter**.

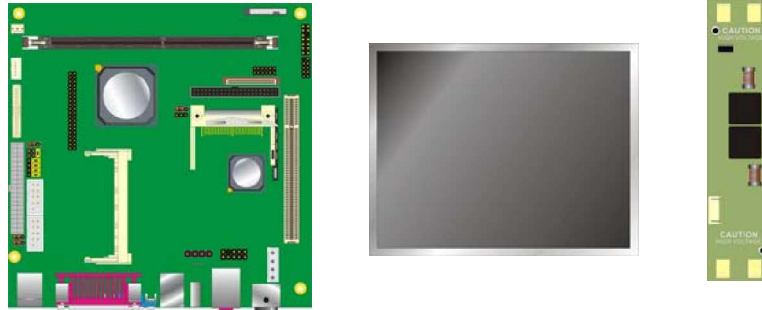

2. Please check the datasheet of the panel to see the voltage of the panel, and set the jumper **JVLCD** to +5V or +3.3V.
3. You would need a LVDS type cable.



4. To connect all of the devices well.

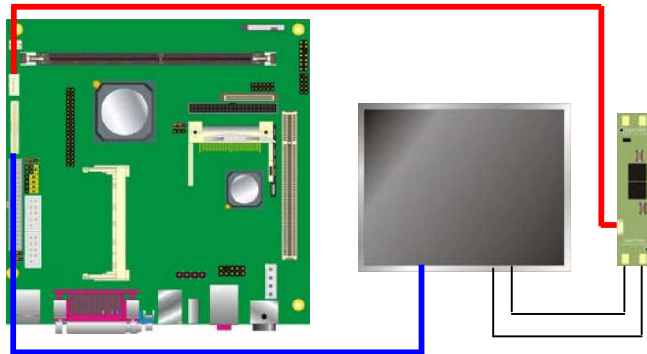

After setup the devices well, you need to select the LCD panel type in the BIOS.

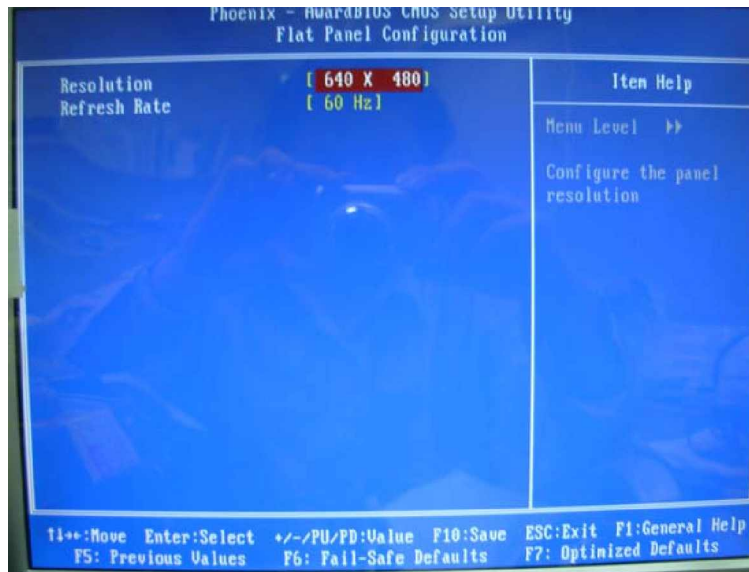

The panel type mapping is list below:

	Panel Number	Resolution
1		640 x 480
2		800 x 600
3		1024x 768

2.10 <Onboard Audio Interface>

The board provides the onboard AC97 2 channel audio interface with Realtek ALC203.

Connector: CN_AUDIO

Type: 10-pin (2 x 5) 2.54mm x 2.54mm-pitch header

Pin	Description	Pin	Description
1	LIN_L	2	Ground
3	LIN_R	4	MIC 2
5	MIC 2	6	Ground
7	N/C	8	FRONTL
9	FRONTR	10	Ground

Connector: CDIN

Type: 4-pin header (pitch = 2.54mm)

Pin	Description
1	CD – Left
2	Ground
3	Ground
4	CD – Right

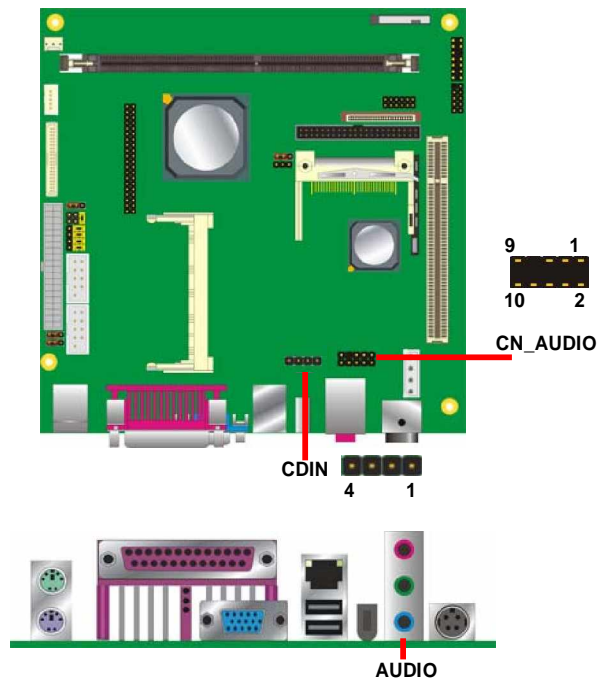

2.11 <USB2.0 Interface>

Based on AMD CS5536, the board provides 2 x USB2.0 ports. The USB2.0 interface provides up to 480Mbps of transferring rate.

Interface	USB2.0
Controller	CS5536
Transfer Rate	Up to 480Mb/s
Output Voltage	500mA

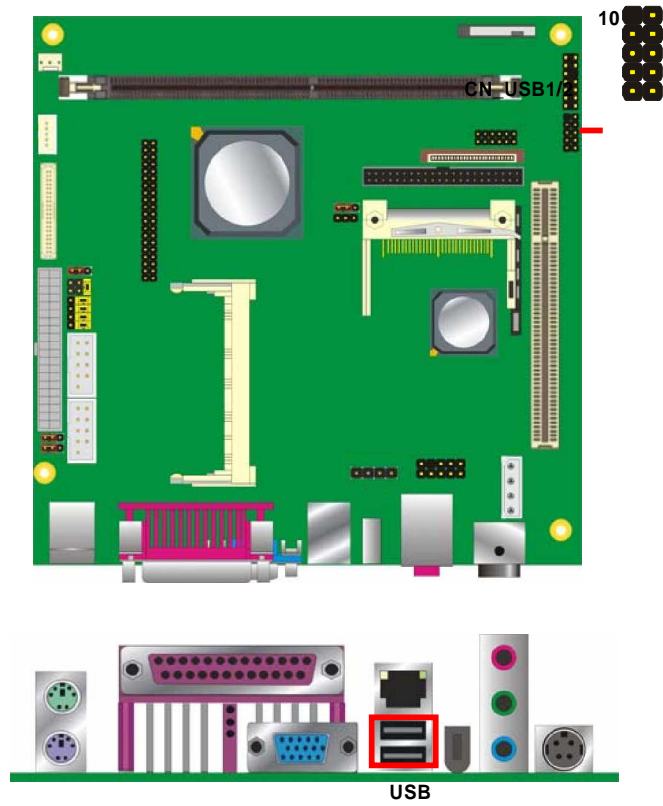

Connector: **CN_USB**

Type: 10-pin (5 x 2) header for USB1/2 Ports

Pin	Description	Pin	Description
1	VCC	2	VCC
3	Data0-	4	Data1-
5	Data0+	6	Data1+
7	Ground	8	Ground
9	Ground	10	N/C

P.S : The USB2.0 will be only active when you connecting with the USB2.0 devices, if you insert an USB1.1 device, the port will be changed to USB1.1 protocol automatically. The transferring rate of USB2.0 as 480Mbps is depending on device capacity, exact transferring rate may not be up to 480Mbps.

2.12 <GPIO Interface>

The board provides a programmable 8-bit digital I/O interface; you can use this general purpose I/O port for system control like POS or KIOSK.

Connector: **CN_DIO**

Type: onboard 2 x 6-pin header, pitch=2.0mm

Pin	Description	Pin	Description
1	Ground	2	Ground
3	GP0	4	GP4
5	GP1	6	GP5
7	GP2	8	GP6
9	GP3	10	GP7
11	VCC	12	+12V

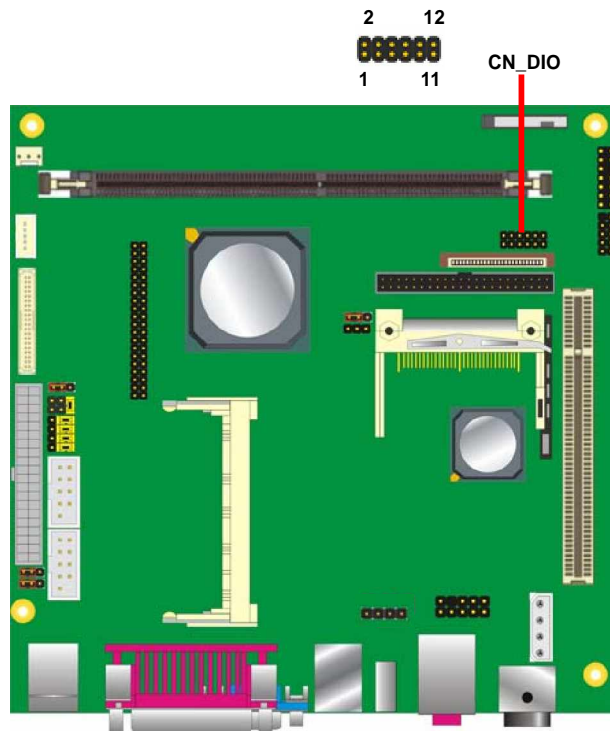

2.13 <Serial Port Jumper Setting >





The onboard CN_COM1 RS232 serial port, with jumper selectable RS232/422/485 for CN_COM2

Connector: **COM1/2**

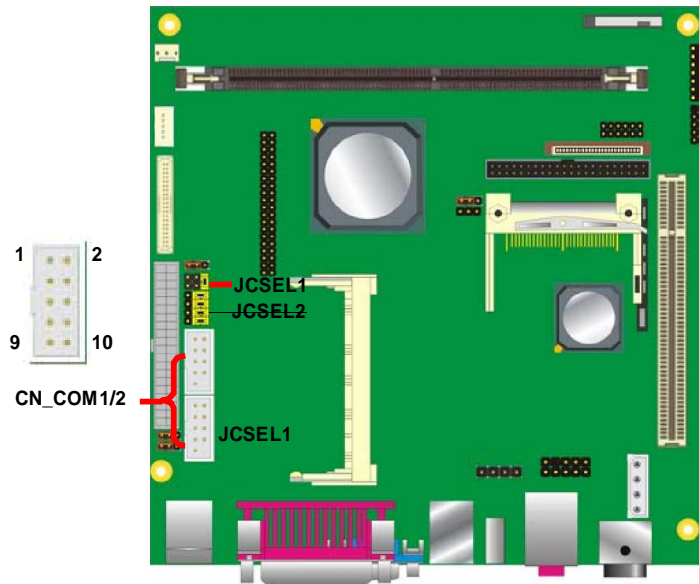
Type: 9-pin D-sub male connector on I/O Panel

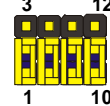
Pin	Description	Pin	Description
1	DCD/422RX-/485-	6	RXD/422RX+/485+
2	TXD/422TX+	7	DTR/422TX-
3	GND	8	DSR
4	RTS	9	CTS
5	R1		



	JCSEL1	JCSEL2
RS-232		
RS-485		
RS-422		

2.14 <Power and Fan Connector>

The **2804090** provides a standard ATX power supply with 20-pin ATX connector, and the board provides one 4-pin P4 additional use power connector for internal power supply and one 3-pin cooler fan connector for system .

2.14.1 <Power Input>

Connector: **ATX**

Type: 20-pin ATX power connector

PIN assignment			
1	3.3V	11	3.3V
2	3.3V	12	-12V
3	GND	13	GND
4	5V	14	PS_ON
5	GND	15	GND
6	5V	16	GND
7	GND	17	GND
8	5V	18	-5V
9	5V	19	5V
10	12V	20	5V

2.14.2 <Power Output>

Connector: **DC_OUT**

Type: 4-pin P-type connector for +5V/+12V output

Pin	Description	Pin	Description	Pin	Description	Pin	Description
1	+5V	2	Ground	3	Ground	4	+12V

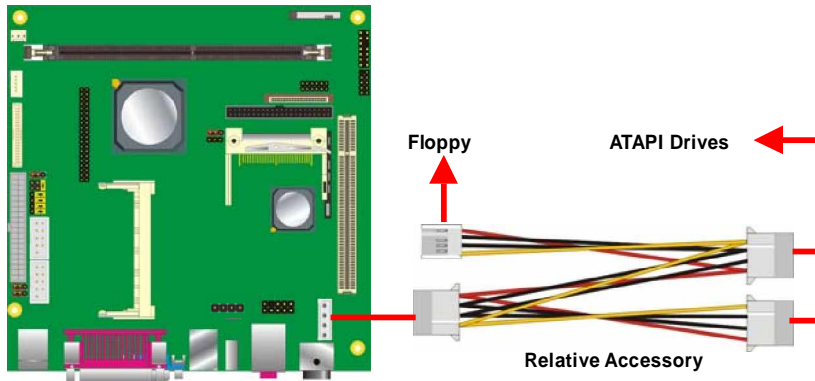

2.14.3 <Fan Connector>

Connector: **SYSFAN**

Type: 3-pin fan wafer connector

Pin	Description	Pin	Description	Pin	Description
1	Ground	2	+12V	3	Fan Control

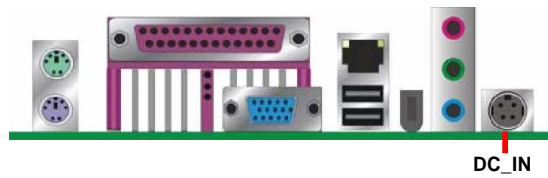
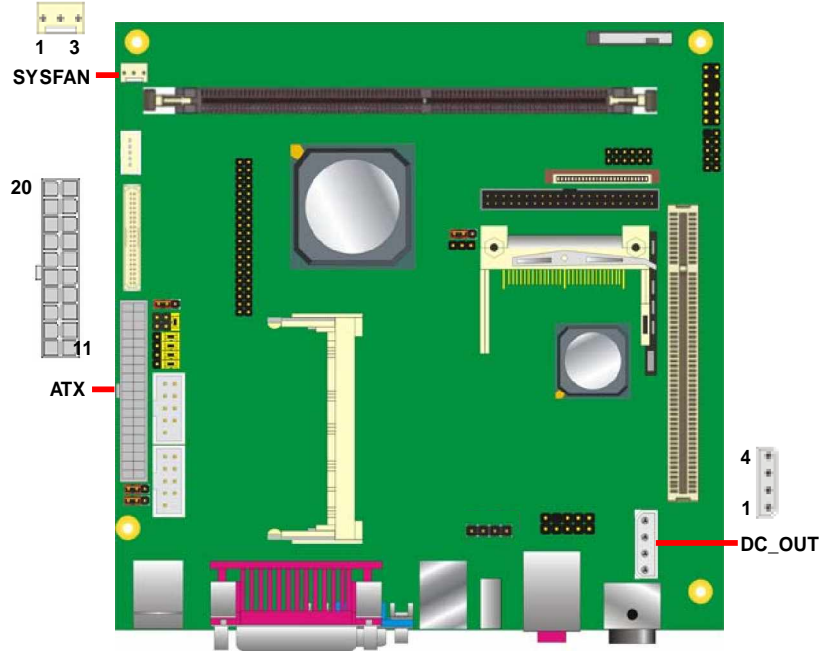

2.15 <Indicator and Switch>

The **JFRNT** provides front control panel of the board, such as power button, reset and beeper, etc. Please check well before you connecting the cables on the chassis.

Connector: **JFRNT**

Type: onboard 14-pin (2 x 7) 2.54-pitch header

Function	Signal	PIN		Signal	Function
IDE LED	Vcc (+)	1	2	(+) Vcc	Power LED
	Active	3	4	N/C	
Reset	Reset	5	6	GND	Speaker
	GND	7	8	Vcc	
N/C		9	10	N/C	
Power Button	PWRBT	11	12	N/C	
	GND	13	14	SPKIN	

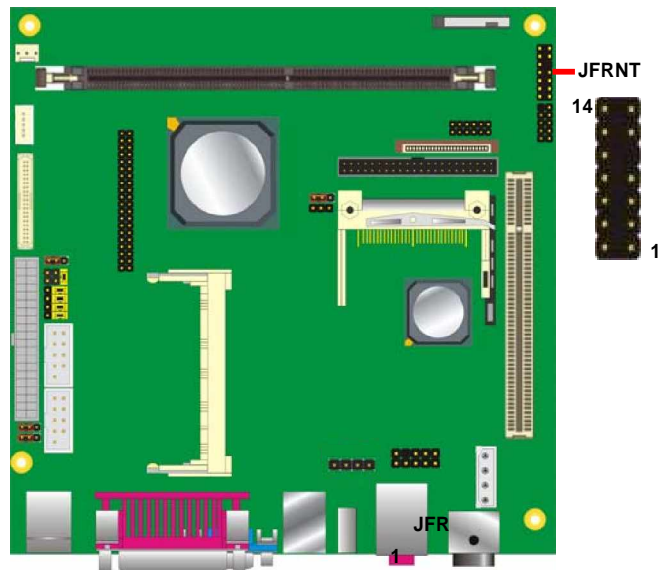

This Page is Intentionally Left Blank.

Chapter 3 <BIOS Setup>

The motherboard uses the Award BIOS for the system configuration. The Award BIOS in the single board computer is a customized version of the industrial standard BIOS for IBM PC AT-compatible computers. It supports Intel x86 and compatible CPU architecture based processors and computers. The BIOS provides critical low-level support for the system central processing, memory and I/O sub-systems.

The BIOS setup program of the single board computer let the customers modify the basic configuration setting. The settings are stored in a dedicated battery-backed memory, NVRAM, retains the information when the power is turned off. If the battery runs out of the power, then the settings of BIOS will come back to the default setting.

The BIOS section of the manual is subject to change without notice and is provided here for reference purpose only. The settings and configurations of the BIOS are current at the time of print, and therefore they may not be exactly the same as that displayed on your screen.

To activate CMOS Setup program, press **DEL** key immediately after you turn on the system. The following message "Press DEL to enter SETUP" should appear in the lower left hand corner of your screen. When you enter the CMOS Setup Utility, the Main Menu will be displayed as **Figure 4-1**. You can use arrow keys to select your function, press **Enter** key to accept the selection and enter the sub-menu.

Figure 4-1 CMOS Setup Utility Main Screen

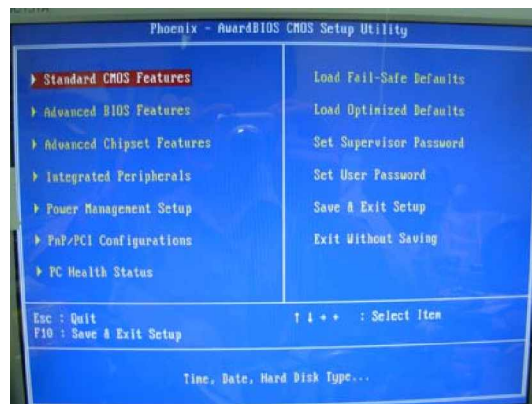

(This Page is Left for Blank)

Appendix A <I/O Port Pin Assignment>

A.1 <IDE Port>

Connector: **IDE1**

Type: 44-pin (22 x 2) box header



Pin	Description	Pin	Description
1	Reset	2	Ground
3	D7	4	D8
5	D6	6	D9
7	D5	8	D10
9	D4	10	D11
11	D3	12	D12
13	D2	14	D13
15	D1	16	D14
17	D0	18	D15
19	Ground	20	N/C
21	REQ	22	Ground
23	IOW-/STOP	24	Ground
25	IOR-/HDMARDY	26	Ground
27	IRDY/DDMARDY	28	Ground
29	DACK-	30	Ground
31	IRQ	32	N/C
33	A1	34	SD
35	A0	36	A2
37	CS1-	38	CS3-
39	HD LED1-	40	Ground
41	Vcc	42	Vcc
43	Ground	44	Ground

A.2 <Floppy Port>Connector: **FDD**

Type: 26-pin connector



Pin	Description	Pin	Description
1	VCC	2	INDEX
3	VCC	4	DRV0
5	VCC	6	DSKCHG
7	DRV1	8	N/C
9	MTR1	10	MTR0
11	RPM	12	DIR
13	N/C	14	STEP
15	Ground	16	WRITE DATA
17	Ground	18	WRITE GATE
19	N/C	20	TRACK 0
21	N/C	22	WRPTR
23	Ground	24	RDATA-
25	Ground	26	SEL

A.3 <Serial Port>Connector: **COM1/2**

Type: 9-pin D-sub male connector on bracket

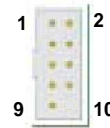

Pin	Description	Pin	Description
1	DCD-	6	DSR-
2	SIN-	7	RTS-
3	SO-	8	CTS-
4	DTR-	9	RI
5	Ground	10	N/C

A.4 <CRT Port>Connector: **CRT**

Type: 15-pin D-sub female connector on I/O Panel

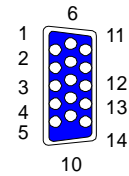

Pin	Description	Pin	Description	Pin	Description
1	RED	6	Ground	11	N/C
2	GREEN	7	Ground	12	5VCDA
3	BLUE	8	Ground	13	HSYNC
4	N/C	9	LVGA5V	14	VSYNC
5	Ground	10	Ground	15	5VCLK

A.5 <LAN Port>Connector: **RJ45**

Type: RJ45 connector with LED on I/O Panel



Pin	1	2	3	4	5	6	7	8
Description	MI0+	MI0-	MI1+	MI2+	MI2-	MI1-	MI3+	MI3-

A.6 < USB Port >Connector: **CN_USB1**

Type: 10-pin (5 x 2) header for dual USB Ports

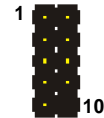

Pin	Description	Pin	Description
1	VCC	2	VCC
3	Data0-	4	Data1-
5	Data0+	6	Data1+
7	Ground	8	Ground
9	Ground	10	N/C

A.7 <PS/2 Keyboard & Mouse Port>

Connector: **Keyboard**

Type: 6-pin Mini-DIN connector on bracket



Pin	1	2	3	4	5	6
Description	N/C	KB_CK	BVCC	IOGND	N/C	KB_DT

Connector: **Mouse**

Type: 6-pin Mini-DIN connector on bracket

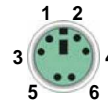

Pin	1	2	3	4	5	6
Description	N/C	MS_CK	BVCC	IOGND	N/C	MS_DT

A.8 < LPT Port >



Connector : **LPT**

Type :25-Pin D-sub female Connector on bracket

Pin	Description	Pin	Description
1	-PSTB	2	PRO0
3	PRO1	4	PRO2
5	PRO3	6	PRO4
7	PRO5	8	PRO6
9	PRO7	10	ACK-
11	BUSY	12	PE
13	SLCT	14	AFD-
15	ERR-	16	INT-
17	SLIN-	18	Ground
19	Ground	20	I/O Ground
21	Ground	22	Ground
23	Ground	24	Ground
25	Ground	26	N/C

This Page is Intentionally Left Blank.

Appendix B <Flash BIOS>

B.1 BIOS Auto Flash Tool

The board is based on Award BIOS and can be updated easily by the BIOS auto flash tool. You can download the tool online at the address below:

<http://www.award.com>

File name of the tool is "awdf flash.exe", it's the utility that can write the data into the BIOS flash chip and update the BIOS.

B.2 Flash Method

1. Please make a bootable floppy disk.
2. Get the last .bin files you want to update and copy it into the disk.
3. Copy awardflash.exe to the disk.
4. Power on the system and flash the BIOS. (Example: C:/ awardflash XXX.bin)
5. Re-start the system.

Any question about the BIOS re-flash please contact your distributors or visit the web-site at below:

<http://www.globalamericaninc.com>

Appendix C <System Resources>

C1.<I/O Port Address Map>

[00000000 - 0000000F]	Direct memory access controller
[00000000 - 00000CF7]	PCI bus
[00000010 - 0000001F]	Motherboard resources
[00000020 - 00000021]	Programmable interrupt controller
[00000022 - 0000002D]	Motherboard resources
[00000030 - 0000003F]	Motherboard resources
[00000040 - 00000043]	System timer
[00000044 - 0000005F]	Motherboard resources
[00000060 - 00000060]	Standard 101/102-Key or Microsoft Natural PS/2 Keyboard
[00000061 - 00000061]	System speaker
[00000062 - 00000063]	Motherboard resources
[00000064 - 00000064]	Standard 101/102-Key or Microsoft Natural PS/2 Keyboard
[00000065 - 0000006F]	Motherboard resources
[00000070 - 00000073]	System CMOS/real time clock
[00000074 - 0000007F]	Motherboard resources
[00000080 - 00000090]	Direct memory access controller
[00000091 - 00000093]	Motherboard resources
[00000094 - 0000009F]	Direct memory access controller
[000000A0 - 000000A1]	Programmable interrupt controller
[000000A2 - 000000BF]	Motherboard resources
[000000C0 - 000000DF]	Direct memory access controller
[000000E0 - 000000EF]	Motherboard resources
[000000F0 - 000000FF]	Numeric data processor
[00000170 - 00000177]	Secondary IDE Channel
[000001F0 - 000001F7]	Primary IDE Channel
[00000274 - 00000277]	ISAPNP Read Data Port
[00000279 - 00000279]	ISAPNP Read Data Port
[00000294 - 00000297]	Motherboard resources

[000002F8 - 000002FF]	Communications Port (COM2)
[00000376 - 00000376]	Secondary IDE Channel
[00000378 - 0000037F]	ECP Printer Port (LPT1)
[000003B0 - 000003BA]	Advanced Micro Devices Win XP Graphics Driver
[000003C0 - 000003DF]	Advanced Micro Devices Win XP Graphics Driver
[000003F0 - 000003F5]	Standard floppy disk controller
[000003F6 - 000003F6]	Primary IDE Channel
[000003F7 - 000003F7]	Standard floppy disk controller
[000003F8 - 000003FF]	Communications Port (COM1)
[000004D0 - 000004D1]	Motherboard resources
[00000778 - 0000077B]	ECP Printer Port (LPT1)
[00000A78 - 00000A7B]	Motherboard resources
[00000B78 - 00000B7B]	Motherboard resources
[00000B8C - 00000BBF]	Motherboard resources
[00000D00 - 0000AC17]	PCI bus
[00000E78 - 00000E7B]	Motherboard resources
[00000F78 - 00000F7B]	Motherboard resources
[00000F8C - 00000FBF]	Motherboard resources
[0000AC20 - 0000FFFF]	PCI bus
[0000FC00 - 0000FCFF]	Realtek RTL8169/8110 Family Gigabit Ethernet NIC
[0000FE00 - 0000FE7F]	GeodeLX Audio Driver (WDM)
[0000FF00 - 0000FF0F]	Standard Dual Channel PCI IDE Controller

C2.<Memory Address Map>

[00000000 - 0009FFFF] System board
[000A0000 - 000BFFFF] Advanced Micro Devices Win XP Graphics Driver
[000A0000 - 000BFFFF] PCI bus
[000C8000 - 000DFFFF] PCI bus
[000F0000 - 000F3FFF] System board
[000F4000 - 000F7FFF] System board
[000F8000 - 000FBFFF] System board
[000FC000 - 000FFFFF] System board
[00100000 - 0F7AFFFF] System board
[0F7B0000 - 0F7BFFFF] System board
[0F7C0000 - FEBFFFFF] PCI bus
[EE000000 - EFFFFFFF] Advanced Micro Devices Win XP Graphics Driver
[EFFE8000 - EFEBFFFF] Advanced Micro Devices Win XP Graphics Driver
[EFFEC000 - EFFFFFFF] Advanced Micro Devices Win XP Graphics Driver
[EFFF0000 - EFFF3FFF] Advanced Micro Devices Win XP Graphics Driver
[EFFF4000 - EFFF7FFF] Advanced Micro Devices Win XP Graphics Driver
[EFFF8000 - EFFFBFFF] Geode LX AES Crypto Driver
[EFFF0000 - EFFFCFFF] OHCI Compliant IEEE 1394 Host Controller
[EFFF0000 - EFFF0FFF] Standard Enhanced PCI to USB Host Controller
[EFFF0000 - EFFF0FFF] Standard OpenHCD USB Host Controller
[EFFF0000 - EFFF0FFF] Realtek RTL8169/8110 Family Gigabit Ethernet NIC
[FEE00000 - FEE0FFFF] System board
[FFFF0000 - FFFFFFFF] System board

C3.<System IRQ Resources>

(ISA) 0	System timer
(ISA) 1	Standard 101/102-Key or Microsoft Natural PS/2 Keyboard
(ISA) 3	Communications Port (COM2)
(ISA) 4	Communications Port (COM1)
(ISA) 6	Standard floppy disk controller
(ISA) 8	System CMOS/real time clock
(ISA) 9	Microsoft ACPI-Compliant System
(ISA) 13	Numeric data processor
(ISA) 14	Primary IDE Channel
(PCI) 5	GeodeLX Audio Driver (WDM)
(PCI) 10	Advanced Micro Devices Win XP Graphics Driver
(PCI) 10	Geode LX AES Crypto Driver
(PCI) 11	OHCI Compliant IEEE 1394 Host Controller
(PCI) 11	Realtek RTL8169/8110 Family Gigabit Ethernet NIC
(PCI) 11	Standard Enhanced PCI to USB Host Controller
(PCI) 11	Standard OpenHCD USB Host Controller

Appendix D <Watch Dog timer Setting >

The watchdog timer makes the system auto-reset while it stops to work for a period. The integrated watchdog timer can be setup as system reset mode by program.

Timeout Value Range

- 1 to 255
- Second or Minute

Program Sample

Watchdog timer setup as system reset with 10 second of timeout

```

2E, 87
2E, 87
2E, 07
2F, 08      Logical Device 8
2E, 30      Activate
2F, 01
2E, F5      Set as Second*
2F, 00
2E, F6      Set as 5
2F, 05

```

* Minute: bit 3 = 0; Second: bit 3 = 1

You can select Timer setting in the BIOS, after setting the time options, the system will reset according to the period of your selection.

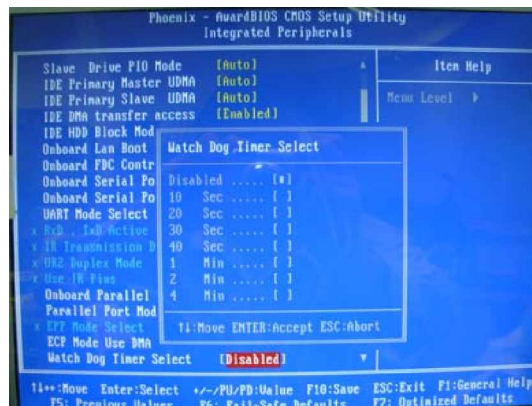

This Page is Intentionally Left Blank.

Any advice or comments about our products and service, or anything we can help you with please don't hesitate to contact with us. We will do our best to support you for your products, projects and business

Global American Inc.

Address: 17 Hampshire Drive
Hudson, NH 03051

TEL: Toll Free (U.S. Only) 800-833-8999
(603)886-3900

FAX: (603)886-4545

Website: <http://www.globalamericaninc.com>

E-Mail: salesinfo@globalamericaninc.com

