



integration with integrity

User's Manual

Mini-ITX Motherboard 2807610

---

---

## **Copyrights**

This manual is copyrighted and all rights are reserved. It does not allow any non authorization in copied, photocopied, translated or reproduced to any electronic or machine readable form in whole or in part without prior written consent from the manufacturer.

In general, the manufacturer will not be liable for any direct, indirect, special, incidental or consequential damages arising from the use of inability to use the product or documentation, even if advised of the possibility of such damages. The manufacturer keeps the rights in the subject to change the contents of this manual without prior notices in order to improve the function design, performance, quality and reliability. The author assumes no responsibility for any errors or omissions, which may appear in this manual, nor does it make a commitment to update the information contained herein.

## **Trademarks**

Intel is a registered trademark of Intel Corporation.

Award is a registered trademark of Award Software, Inc.

All other trademarks, products and or product's name mentioned herein are mentioned for identification purposes only, and may be trademarks and/or registered trademarks of their respective companies or owners.

---

## Packing List

Please check the package before you starting setup the system

### Hardware:

2807610 series motherboard x 1

### Cable Kit:

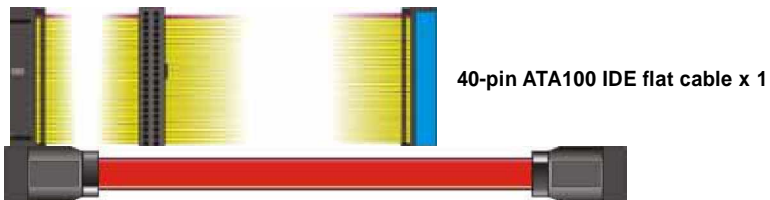

40-pin ATA100 IDE flat cable x 1

Serial ATA ribbon cable x 1



I/O Shield x 1

# Index

<b>Chapter 1 &lt;Introduction&gt;</b> .....	<b>7</b>
1.1 <Product Overview>.....	7
1.2 <Product Specification> .....	8
1.3 <Mechanical Drawing>.....	10
1.4 <Block Diagram>.....	11
<b>Chapter 2 &lt;Hardware Setup&gt;</b> .....	<b>12</b>
2.1 <Connector Location>.....	12
2.2 <Jumper Reference> .....	13
2.3 <Connector Reference> .....	14
2.3.1 <Internal Connector>.....	14
2.3.2 <External Connector>.....	14
2.4 <CPU and Memory Setup> .....	15
2.4.1 < CPU>.....	15
2.4.2 <Memory> .....	15
2.5 <CMOS Setup>.....	16
2.6 <Enhanced IDE & CF Interface>.....	17
2.7 <Serial ATA Interface>.....	18
2.8 <LAN Interface> .....	19
2.9 <Onboard Display Interface> .....	20
2.9.1 <Analog VGA Interface> .....	20
2.10 <Onboard Audio Interface>.....	21
2.11 <Power and Fan Connector> .....	22
2.11.1 <Power Input> .....	22
2.11.2 <Fan Connector>.....	22
2.12 <Indicator and Switch>.....	23
<b>Chapter 3 &lt;System Configuration&gt;</b> .....	<b>25</b>
3.1 <SATA RAID Configuration>.....	25

3.2 <Audio Configuration> .....	27
3.3 <Display Configuration> .....	28
<b>Chapter 4 &lt;BIOS Setup&gt; .....</b>	<b>30</b>
<b>Appendix A &lt;I/O Port Pin Assignment&gt; .....</b>	<b>32</b>
A.1 <IDE Port> .....	32
A.2 <IrDA Port> .....	32
A.3 <VGA Port >.....	33
A.4 <Serial ATA Port>.....	33
A.5 <Serial Port> .....	33
A.6 <LAN Port> .....	34
A.7 <PS/2 Keyboard & Mouse Port>.....	34
A.8 <CPU Voltage>.....	35
A.9<USB Interface>.....	35
<b>Appendix B &lt;Flash BIOS&gt;.....</b>	<b>37</b>
B.1 BIOS Auto Flash Tool .....	37
B.2 Flash Method.....	37
<b>Appendix C &lt;System Resources&gt; .....</b>	<b>39</b>
C.1 <I/O Port Address Map>.....	39
C.2 <Memory Address Map> .....	41
C.3 <System IRQ & DMA Resource> .....	42
C.3.1 <IRQ> .....	42
<b>Contact Information .....</b>	<b>44</b>

**(The Page is Left For Blank)**

# Chapter 1 <Introduction>

## 1.1 <Product Overview>

**2807610** is the Mini-ITX motherboard based on VIA chipset. It integrates the last VIA embedded chipset for KN400A with VT8237R, DDR266/333/400 SDRAM, and serial ATA with RAID to provide the economical embedded platform.

### **VIA KN400A & VT8237R Chipset**

The board comes with the VIA last embedded chipset of KN400A, supports DDR266/333/400 SDRAM, integrated the S3 Graphics UniChrome Pro IGP graphics core, hardware MPEG-2 and MPEG-4 acceleration.

The VT8237R provides the board to support Ultra V-Link (1GB/s) with KN400A, two serial ATA ports with RAID array function, 4 x USB2.0 ports and 5.1 channel AC97 audio.

### **Multimedia solution**

Based on VIA KN400A chipset, the board provides, which supports single independent display with CRT.

### **LAN Interface**

**2807610** also comes with one 10/100Mbps LAN interface, support boot-on-LAN and wake-on-LAN function.

### **High Speed Hot-plug Interface**

Based on VIA VT8237R, the board provides 4 USB2.0 interfaces with up to 480Mbps of transferring rate.

### **Expanded UCR for remote Operating SETUP Bios Feature**

**Expanded Universal Console Redirection (UCR)** is a feature for monitoring POST messages and running Setup and an operation system from a remote serial terminal.

## 1.2 <Product Specification>

### General Specification

Form Factor	Mini-ITX motherboard
CPU	AMD Geode NX Processors NX 1250@6W/1500@6W Processors supported Fanless with CPU heatsink
Memory	1 x 184-pin DDR 266/333/400 SDRAM up to 1GB Unbuffered, none-ECC memory supported only
Chipset	VIA KN400A and VT8237R
BIOS	Phoenix-Award v6.00PG 4Mb PnP flash BIOS
Green Function	Power saving mode includes doze, standby and suspend modes. ACPI version 1.0 and APM version 1.2 compliant
Real Time Clock	VIA VT8237R built-in RTC with lithium battery
Enhanced IDE	Enhanced IDE interface supports dual channels and up to 2 ATAPI devices at Ultra DMA100 One 40-pin onboard
Serial ATA	VIA VT8237R integrates 2 Serial ATA interface RAID 0, 1 array Technology supported

### Multi-I/O Port

Chipset	VIA VT8237R with Winbond W83697HF controller
Serial Port	one external RS-232 serial port on rear I/O panel.
USB Port	Four Hi-Speed USB 2.0 ports with 480Mbps of transfer rate.
Parallel Port	One external parallel port on rear I/O panel.
IrDA Port	One IrDA compliant Infrared interface supports SIR.
K/B & Mouse	External PS/2 keyboard and mouse ports on rear I/O panel
Hardware Monitor	Fan speed, CPU temperature and voltage monitoring

### VGA Display Interface

Chipset	VIA KN400A built-in S3 Graphics UniChrome Pro IGP graphics core
Core Frequency	200MHz
Memory	BIOS selectable 16/32/64MB shard with system memory
Display Type	CRT, LCD monitor with analog display
Connector	External DB15 female connector on rear I/O panel



**Ethernet Interface**

Chipset	AMD AM79C874VI
Type	10Base-T / 100Base-TX auto-switching Fast Ethernet Full duplex, IEEE802.3U compliant
Connector	One External RJ45 connectors with LED on rear I/O panel

**Audio Interface**

Chipset	Realtek® ALC655 AC97 3D audio codec
Interface	5.1 channel 3D audio with Line-in, Line-out and MIC-in
Connector	External Audio phone jack for Line-out/Front, Line-in/Rear and MIC(stereo)-in/Center Onboard audio connector with pin header Onboard CD-IN connector

**Expansive Interface**

PCI	1 x PCI slot supports up to one PCI devices through riser card
-----	--

**Power and Environment**

Power Requirement	Standard ATX <b>20-pin</b> power supply
Dimension	170 (L) x 170 (H) mm
Temperature	Operating within 0 ~ 60°C (32 ~ 140°F) Storage within -20 ~ 85°C (-4 ~ 185°F)

**Software support**

Operation System	Windows 2000, Windows XP Linux (Fedora Core 1, Mandrake 9.2 and Red Hat 9.0)
------------------	---

**Ordering Code**

<b>2807610A</b>	AMD Geode NX processors Mini-ITX motherboard with onboard VGA, LAN, SATA, USB 2.0 Ports, Audio, 1 x RS232 serial port, S/PDIF, Parallel port
<b>2807610B</b>	Same as 2807610 and with AMD Geode NX 1250 processor
<b>2807610C</b>	Same as 2807610 and with AMD Geode NX 1500 processor

1. Please do not order other Mini-AGP modules excluded in the list for this board.
2. The specifications may be different as the actual production.

For further product information please visit the website at <http://www.globalamericaninc.com/>

## 1.3 &lt;Mechanical Drawing&gt;

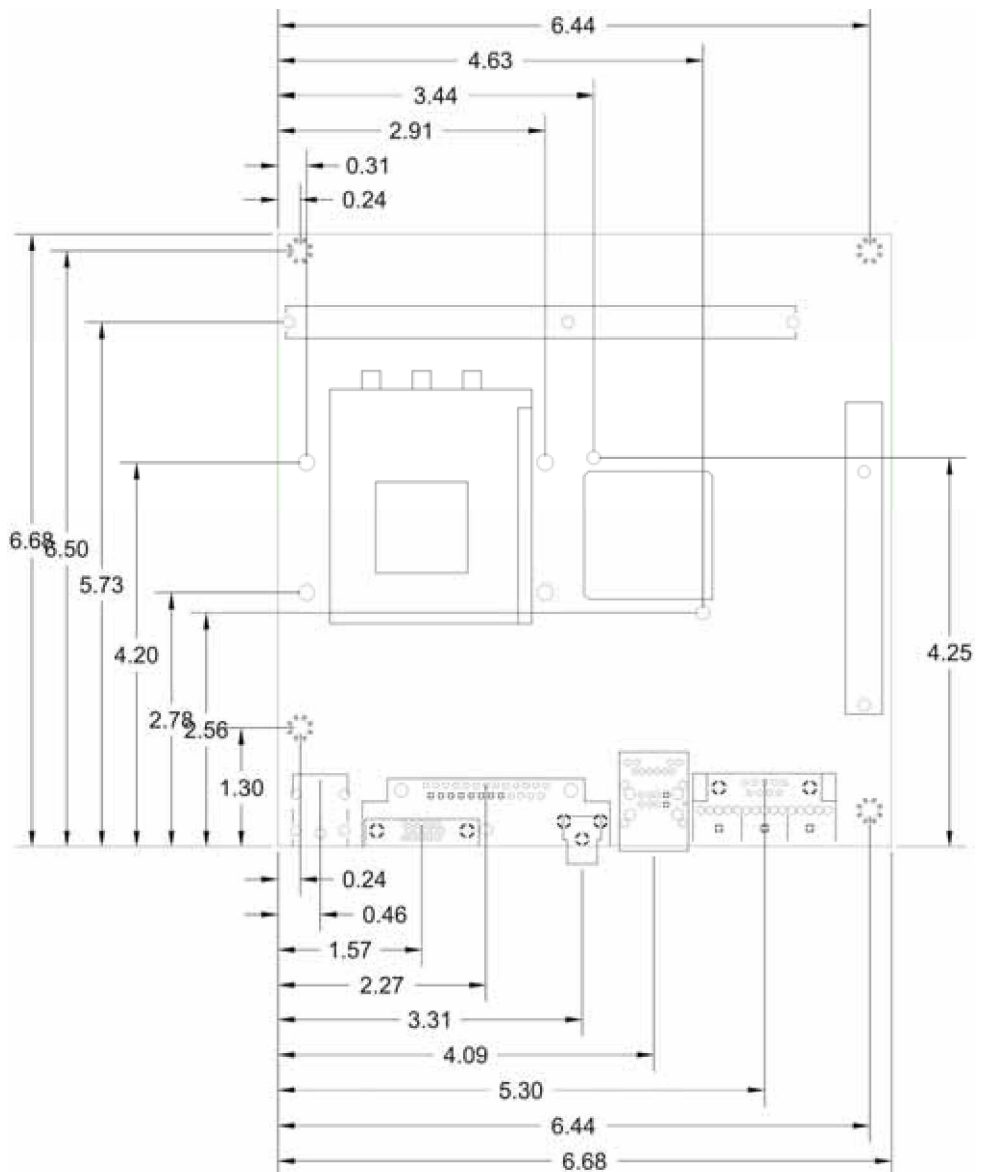

# 1.4 <Block Diagram>

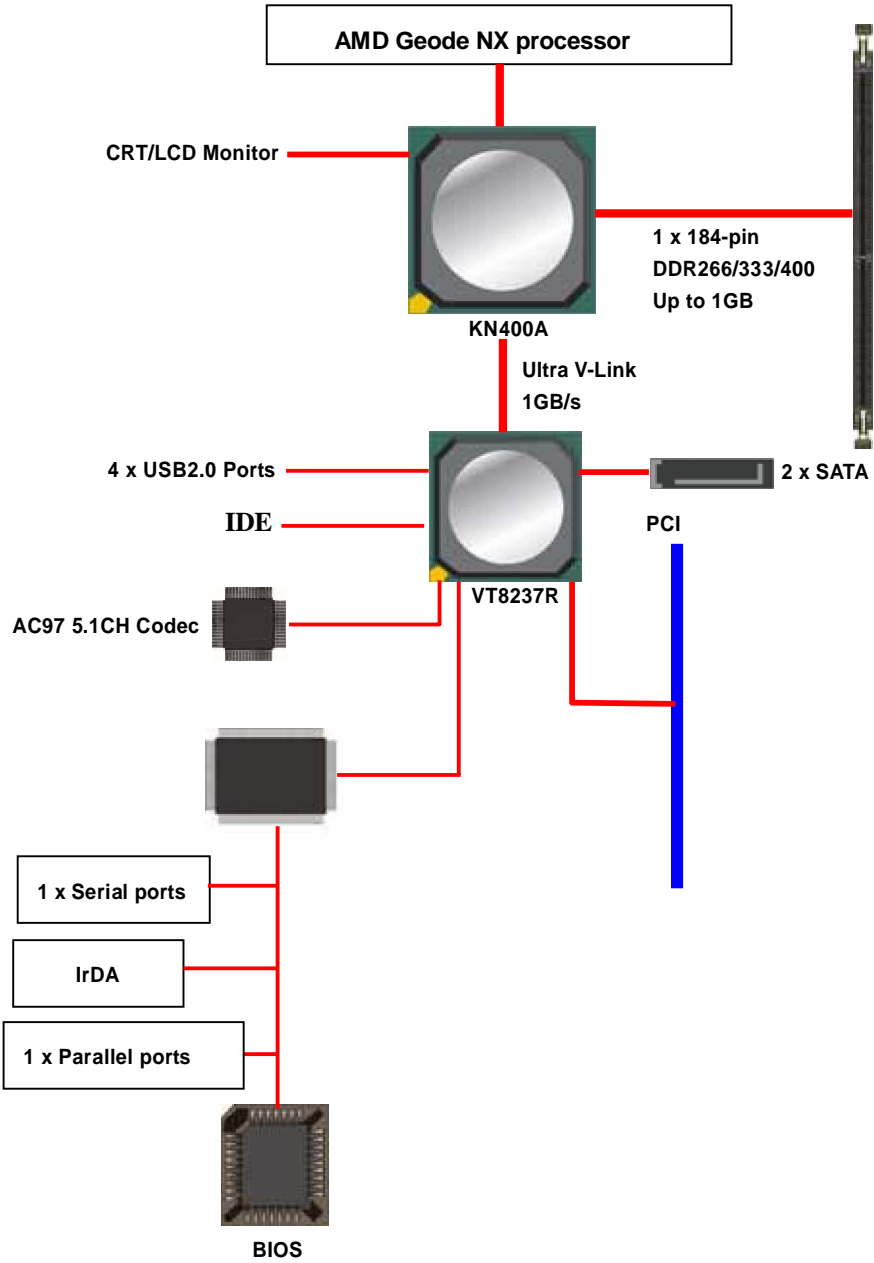

# Chapter 2 <Hardware Setup>

## 2.1 <Connector Location>

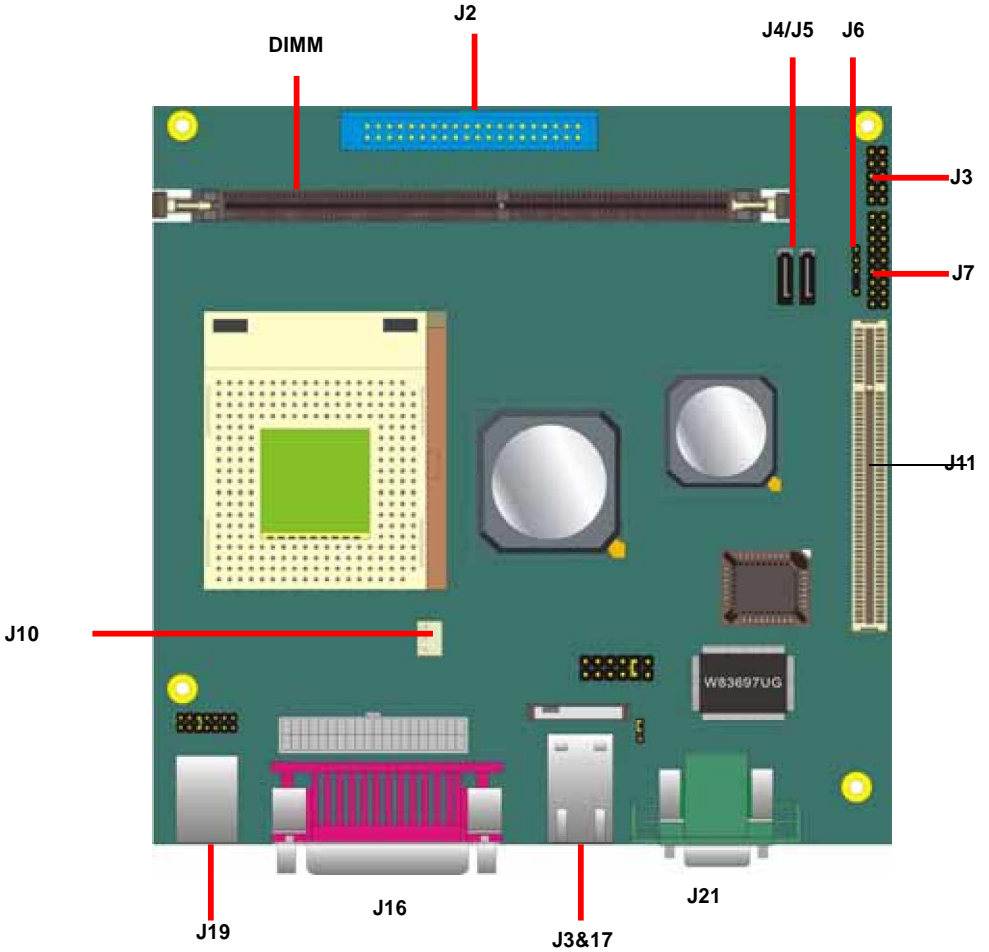

## 2.2 <Jumper Reference>

Jumper	Function
J13	CMOS Operating/Clear Setting.
J14	Setting CPU voltage.

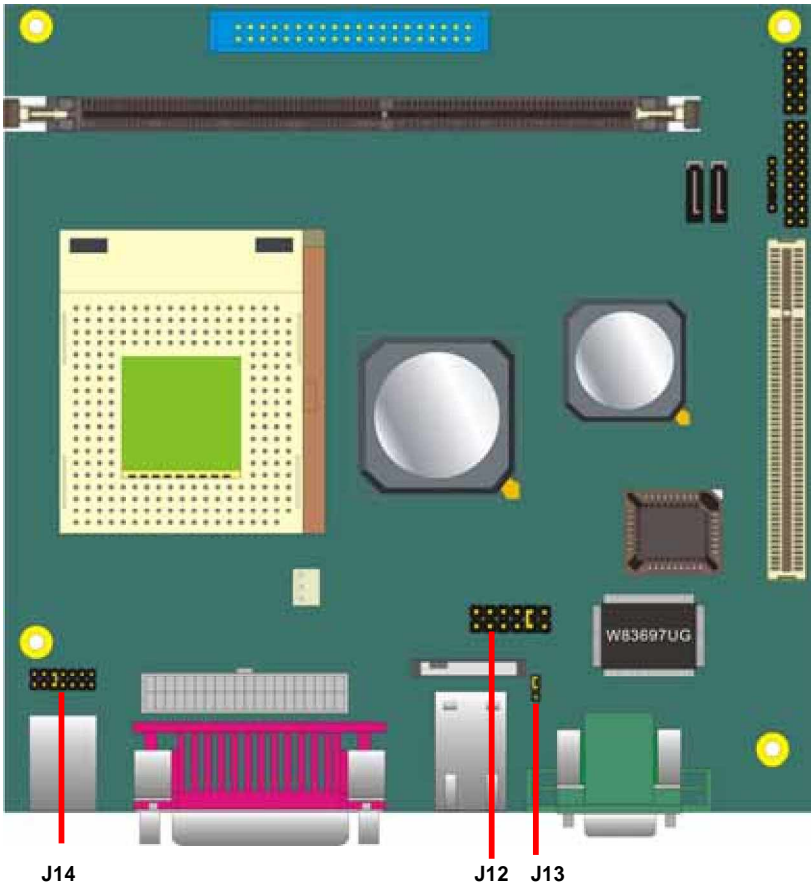

## 2.3 <Connector Reference>

### 2.3.1 <Internal Connector>

Connector	Function	Remark
DIMM	184-pin DDR SDRAM DIMM	Standard
J2	40-pin primary IDE connector	Standard
J4/J5	7-pin Serial ATA connector	Standard
J15	20-pin power supply connector	Standard
J3	5 x 2-pin USB connector	Standard
J10	3-pin CPU cooler fan connector	Standard
J7	14-pin switch/indicator connector	Standard

### 2.3.2 <External Connector>

Connector	Function	Remark
J18	DB15 VGA connector	Standard
J3/J17	Dual USB and RJ45 LAN connector	Standard
J21	Serial port connector	Standard
J19	PS/2 Keyboard/Mouse connector	Standard
J20	S/PDIF Digital Audio out	RCA
J21(Green)	Audio Line-out port	Standard
J21(Blue)	Audio Line-in port	Standard
J21(Pink)	Audio Microphone input port	Standard
J16	One parallel port	Standard

## 2.4 <CPU and Memory Setup>

### 2.4.1 < CPU>

The board supports AMD Geode NX 1250/1500 processor, with CPU headsink only .

### 2.4.2 <Memory>

The board supports one 184-pin DDR266/333/400 SDRAM and up to 1GB of capacity, only non-ECC, unbuffered memory is supported.

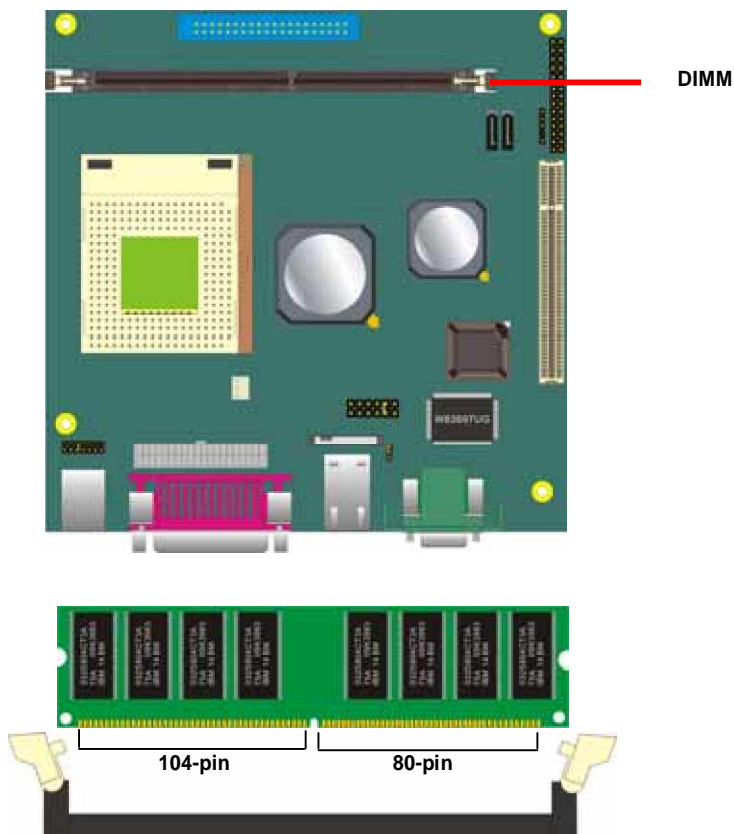

Please check the pin number to match the socket side well before installing memory module.

## 2.5 <CMOS Setup>

The board's data of CMOS can be setting in BIOS. If the board refuses to boot due to inappropriate CMOS settings, here is how to proceed to clear (reset) the CMOS to its default values.

**Jumper: J13**

**Type: Onboard 3-pin jumper**

J13	Mode
1-2	Normal Operation
2-3	Clear CMOS

Default setting

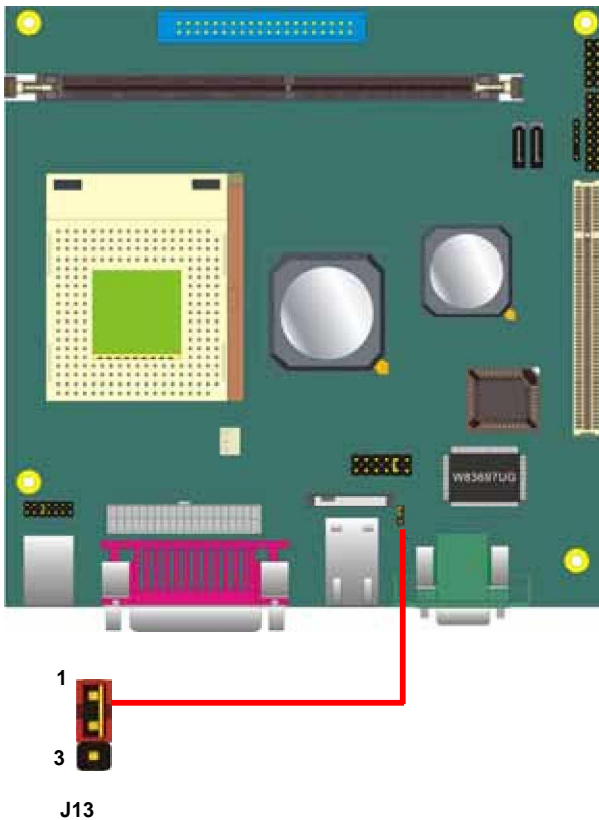



## 2.6 <Enhanced IDE & CF Interface>

The board supports one enhanced IDE interface, one channel for 2 ATAPI devices with ATA100.

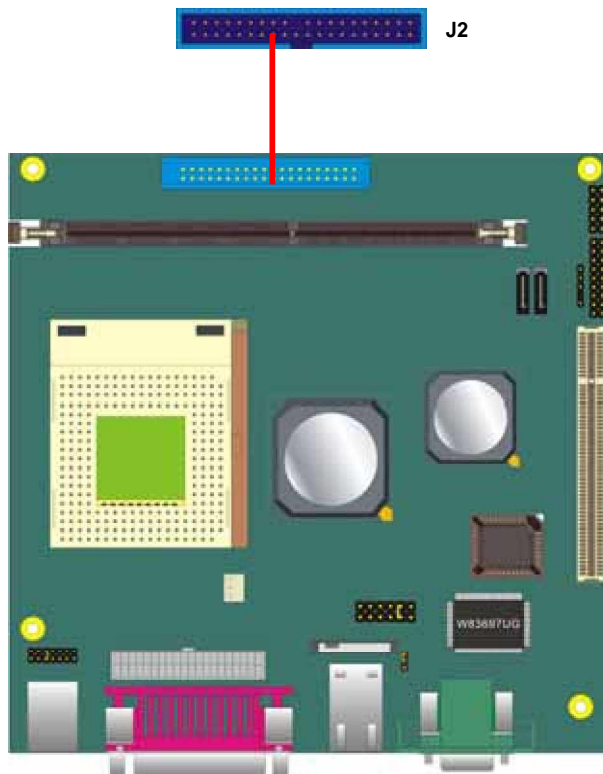

## 2.7 <Serial ATA Interface>

Based on VIA VT8237R Southbridge, the board supports two Serial ATA interfaces with RAID 0 and 1 array function. The following is the list of the specification of the Serial ATA.

1. Complies with Serial ATA Specification Revision 1.0
2. Dual Channel master mode PCI
3. On-chip two-channel Serial ATA (S-ATA) for support of up to two S-ATA devices directly.
4. S-ATA drive transfer rate is capable of up to 150 MB/s per channel (serial speed of 1.5 Gbit/s).

*For more information please visit VIA website ([www.via.com.tw](http://www.via.com.tw))*

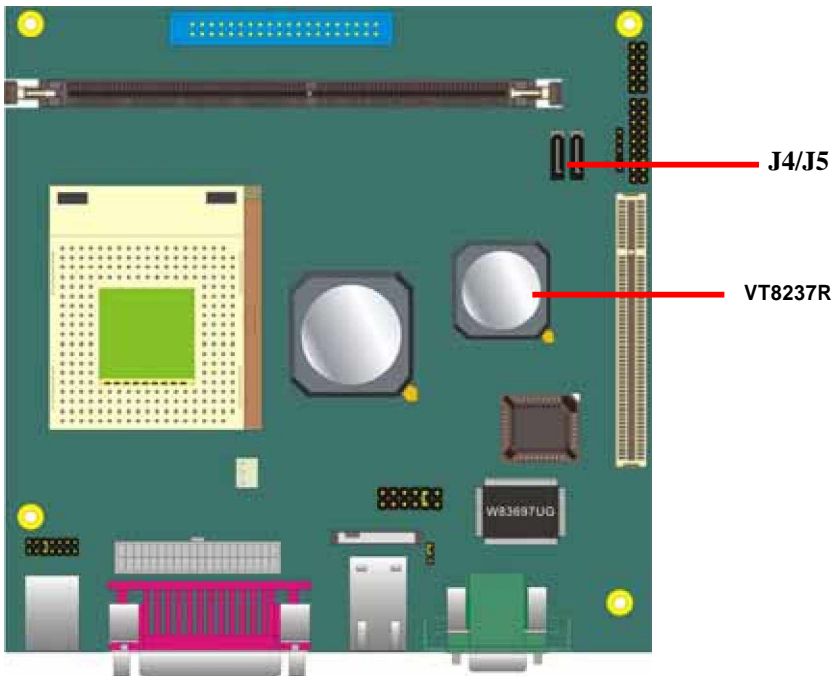

## 2.9 <LAN Interface>

The board provides one 10/100Mbps LAN interfaces with AM79C874VI , and compliant with standard IEEE 802.3 Ethernet interface for 100BASE-TX.

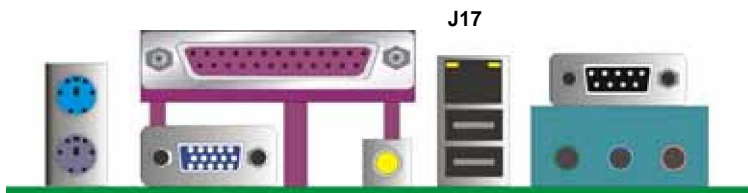

## 2.10 <Onboard Display Interface>

Based on VIA KN400A, the board supports integrated S3 Graphics UniChrome Pro IGP graphics, with BIOS selectable 16/32/64MB shared with system memory for frame buffer.

### 2.10.1 <Analog VGA Interface>

The board provides a DB15 VGA connector on the rear I/O panel .



J18

## 2.11 <Onboard Audio Interface>

The board provides the onboard Realtek ALC 655 AC97 5.1-channel audio interface , with three phone jacks on rear I/O panel for Line-out, Line-in, MIC(stereo)-in as 2-channel sound system, and Front, Rear, Center as 5.1-channel sound system.

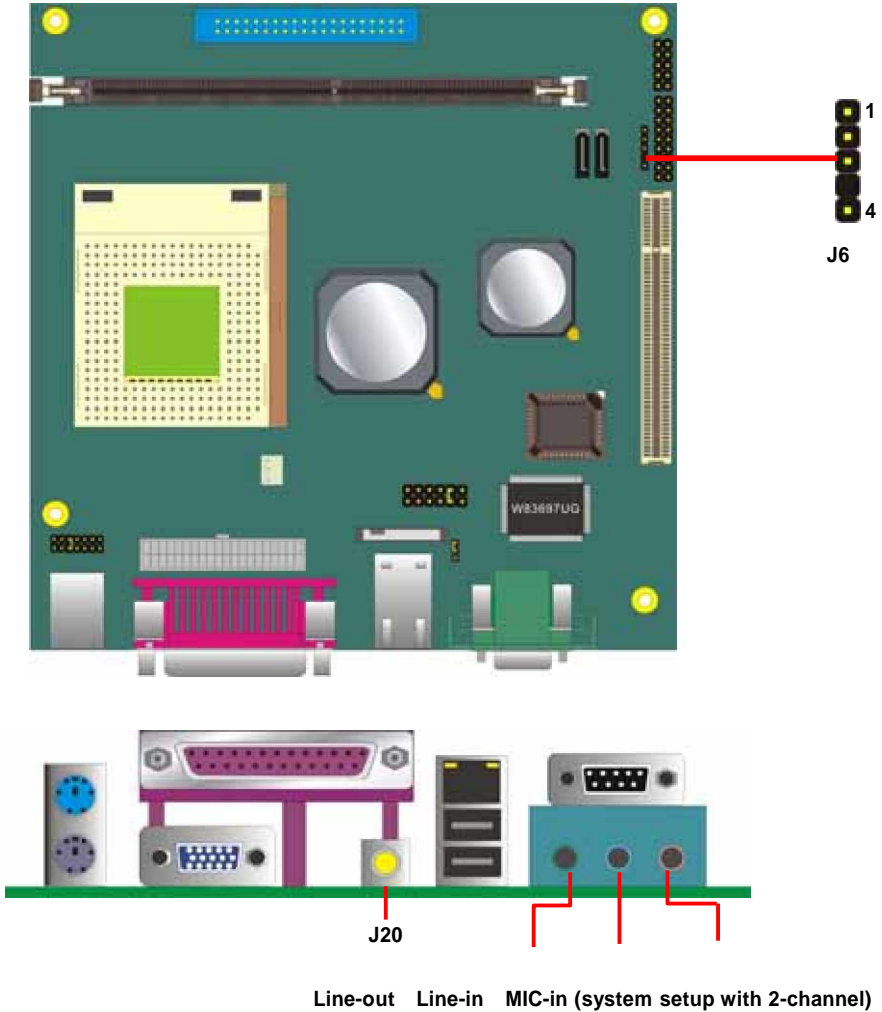

## 2.15 <Power and Fan Connector>

### 2.15.1 <Power Input>

Connector: **J15**

Type: 20-pin ATX power connector

PIN assignment			
1	12V	11	5V
2	5VSB	12	5V
3	PWOK	13	-5V
4	GND	14	GND
5	5V	15	GND
6	GND	16	GND
7	5V	17	PSON
8	GND	18	GND
9	3.3V	19	-12
10	3.3V	20	3.3V

### 2.15.2 <Fan Connector>

Connector: **J10**

Type: 3-pin fan wafer connector

Pin	Description	Pin	Description	Pin	Description
1	Ground	2	+12V	3	Fan Sensor

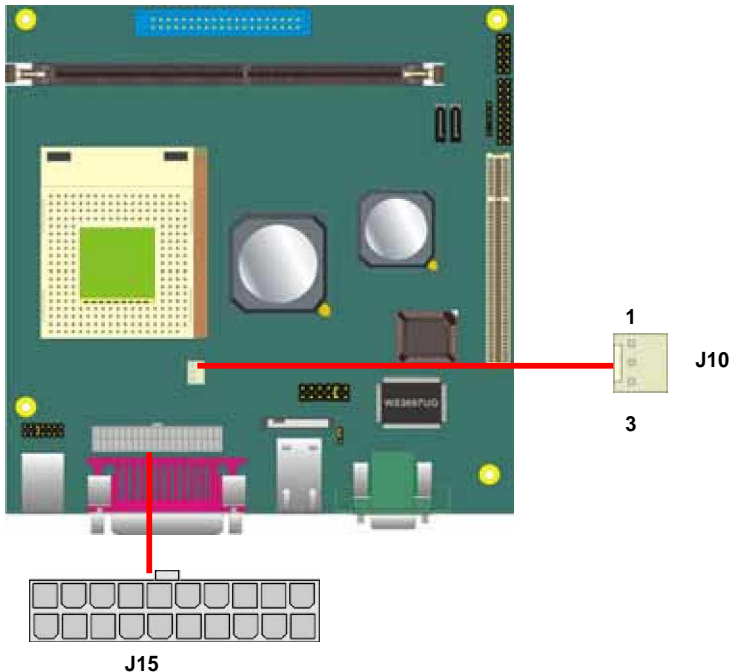

## 2.16 <Indicator and Switch>

The J7 provides front control panel of the board, such as power button, reset and beeper, etc. Please check well before you connecting the cables on the chassis.

Function	Signal	PIN		Signal	Function
	VCC	1	2	HD_H +	
	PWR_LED+	3	4	HD_L -	
	PWR_LED-	5	6	PWR_SW+	
	SPK+	7	8	PWR_SW -	
	N/C	9	10	RST_SW +	
	N/C	11	12	RST_SW -	
	SPK-	13	14	SLPLED +	
	SLPBTN_L+	15	16	SLPLED -	
	SLPBTN_L-	17	18	N/C	

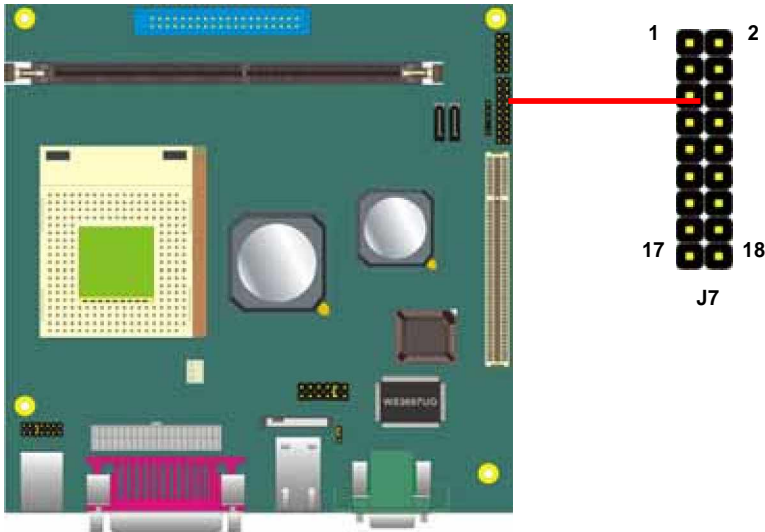

**(This Page is Left For Blank)**



## Chapter 3 <System Configuration>

### 3.1 <SATA RAID Configuration>

The board supports two Serial ATA ports onboard, and supports RAID 0, 1 and disk array, the RAID 0, 1 and specified below:

**RAID 0 (Striping):** Two hard drives operating as one drive for optimized data R/W performance. It needs two unused drives to build this operation.

**RAID 1 (Mirroring):** Copies the data from first drive to second drive for data security, and if one drive fails, the system would access the applications to the workable drive. It needs two unused drives or one used and one unused drive to build this operation. The second drive must be the same or larger size than first one.

To build Serial ATA disk array, please press <TAB> while booting up the system before entering OS, and follow the instructions to edit the RAID function.

(Selectable Functions)

(Option Instruction)

Channel	Drive Name	Array Name	Mode	Size(Gb)	Status
Serial_Ch0 Master	ST3120026AS	ARRAY 0	SATA	111.79	Boot
Serial_Ch1 Master	Maxtor 6Y120W0	ARRAY 0	SATA	114.49	Boot

(Disk Statement)

You also can edit disk array under OS, please install the VIA RAID Utility in the driver CD.

(To getting start, please click here to learn more information)

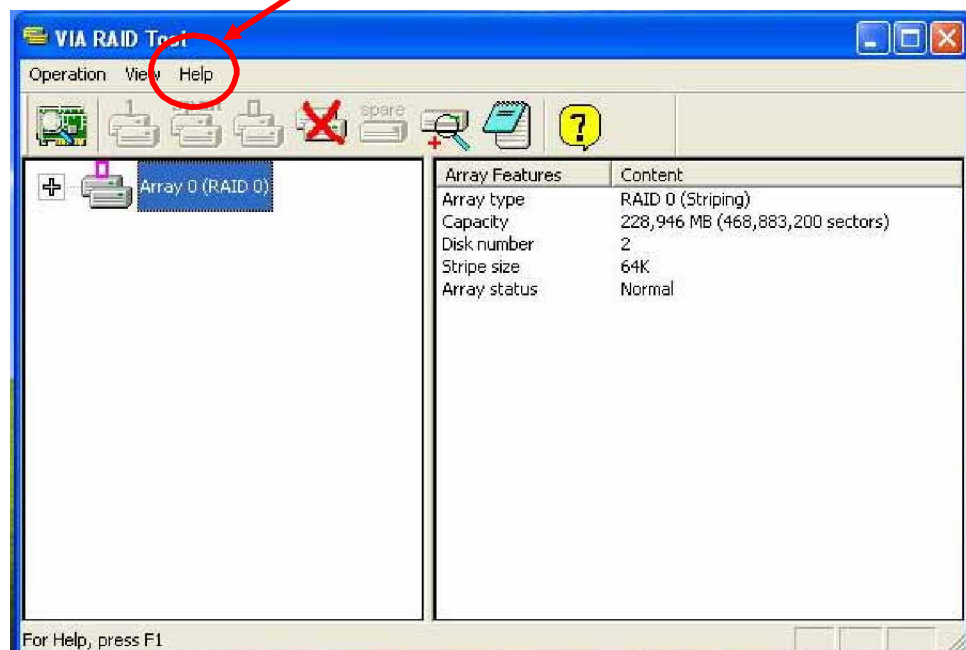

(Click here to build RAID 0)

(Click here to build RAID JBOD)

(Click here to build RAID 0)

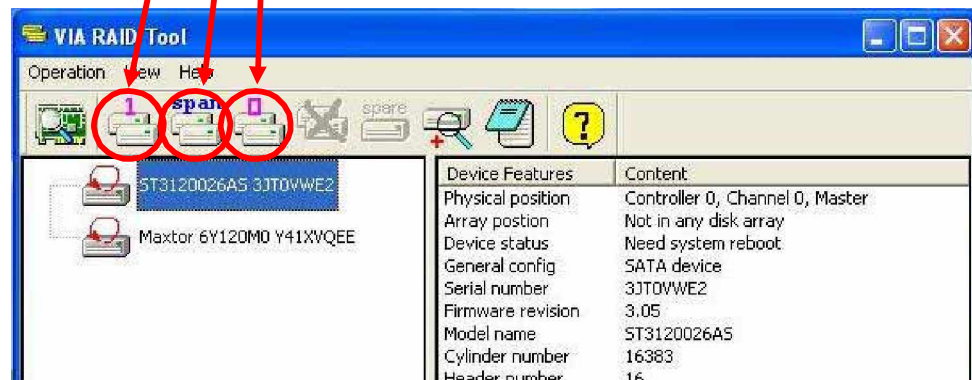

## 3.2 <Audio Configuration>

The board provides 5.1 channel audio interface with driver installed, please install the VIA audio driver in the CD before getting start to enjoy the 5.1 channel sound system.

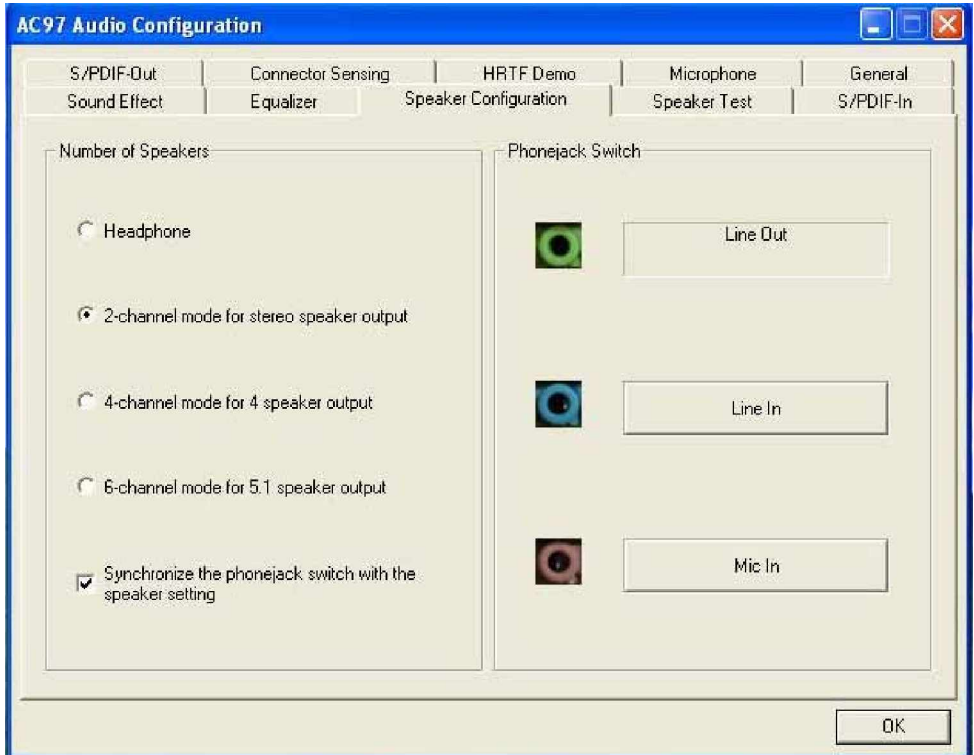

### 3.3 <Display Configuration>

The board provides onboard analog VGA interface, and , please install the VIA video driver before enjoy the vivid display.

Based on the VIA KN400A with S3 UniChrome Pro graphic, the board provides dual display function for clone or extended desktop modes with secondary display device attached.

After installing video driver, please launch the desktop display properties.

For secondary display device, you have two options selectable.

For more display properties setting, please click “Advanced” button.

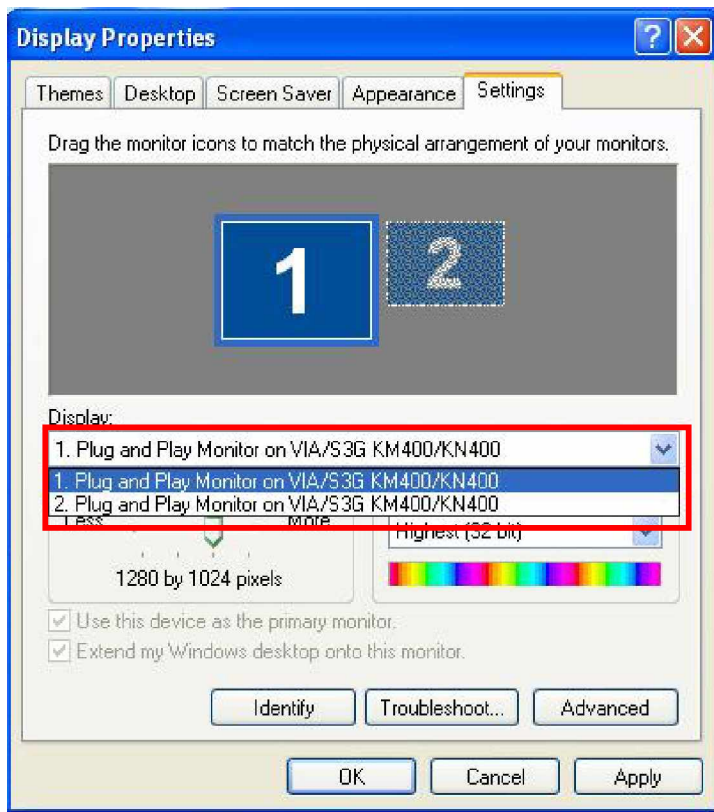

Please select S3Display for advanced device setting.

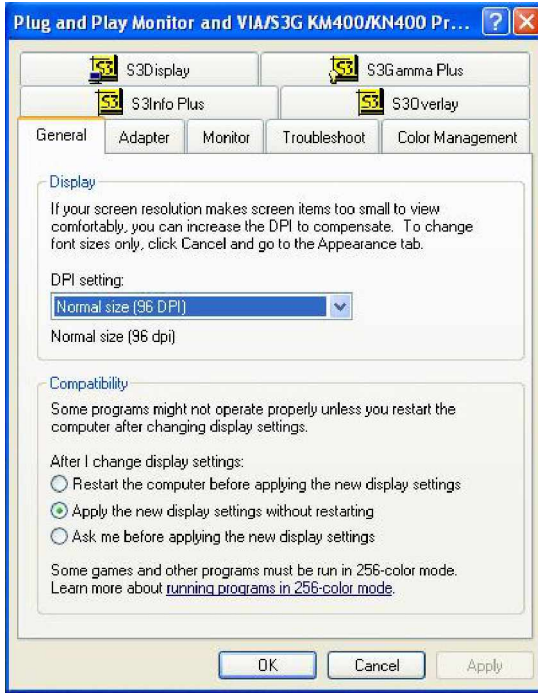

## Chapter 4 <BIOS Setup>

The motherboard uses the Award BIOS for the system configuration. The Award BIOS in the single board computer is a customized version of the industrial standard BIOS for IBM PC AT-compatible computers. It supports Intel x86 and compatible CPU architecture based processors and computers. The BIOS provides critical low-level support for the system central processing, memory and I/O sub-systems.

The BIOS setup program of the single board computer let the customers modify the basic configuration setting. The settings are stored in a dedicated battery-backed memory, NVRAM, retains the information when the power is turned off. If the battery runs out of the power, then the settings of BIOS will come back to the default setting.

The BIOS section of the manual is subject to change without notice and is provided here for reference purpose only. The settings and configurations of the BIOS are current at the time of print, and therefore they may not be exactly the same as that displayed on your screen.

To activate CMOS Setup program, press **DEL** key immediately after you turn on the system. The following message "Press DEL to enter SETUP" should appear in the lower left hand corner of your screen. When you enter the CMOS Setup Utility, the Main Menu will be displayed as **Figure 4-1**. You can use arrow keys to select your function, press **Enter** key to accept the selection and enter the sub-menu.

**Figure 4-1** CMOS Setup Utility Main Screen



(This Page is Left for Blank)

## Appendix A <I/O Port Pin Assignment>

### A.1 <IDE Port>

Connector: **J2**

Type: 40-pin (20 x 2) box header



Pin	Description	Pin	Description
1	Reset	2	Ground
3	D7	4	D8
5	D6	6	D9
7	D5	8	D10
9	D4	10	D11
11	D3	12	D12
13	D2	14	D13
15	D1	16	D14
17	D0	18	D15
19	Ground	20	VCC
21	REQ	22	Ground
23	IOW-/STOP	24	Ground
25	IOR-/HDMARDY	26	Ground
27	IRDY/DDMARDY	28	DMA66#/DMA33
29	DACK-	30	Ground
31	IRQ	32	N/C
33	A1	34	CBLID
35	A0	36	A2
37	CS0 (MASTER CS)	38	CS1 (SLAVE CS)
39	LED ACT-	40	Ground

### A.2 <IrDA Port>

Connector: **J6**

Type: 5-pin header for SIR Ports



Pin	Description
1	Vcc
2	N/C
3	IRRX
4	Ground
5	IRTX



### A.3 < VGA Port >

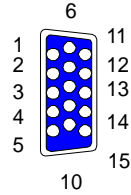

Connector: **J18**

Type: 15-pin D-sub female connector on bracket

Pin	Description	Pin	Description	Pin	Description
1	RED	6	Ground	11	N/C
2	GREEN	7	Ground	12	5VCCA
3	BLUE	8	Ground	13	HSYNC
4	N/C	9	LVGA5V	14	VSYNC
5	Ground	10	Ground	15	5VCLK

### A.4 <Serial ATA Port>

Connector: **J4/J5**

Type: 7-pin wafer connector

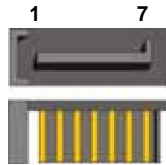

1	2	3	4	5	6	7
GND	RSATA_TXP1	RSATA_TXN1	GND	RSATA_RXN1	RSATA_RXP1	GND

### A.5 <Serial Port>

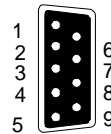

Connector: **COM1**

Type: 9-pin D-sub male connector on bracket

Pin	Description	Pin	Description
1	DCD	6	DSR
2	SIN	7	RTS
3	SO	8	CTS
4	DTR	9	RI
5	Ground		

## A.6 <LAN Port>

Connector: **J17**

Type: RJ45 connector with LED on bracket

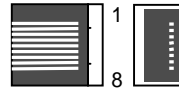

Pin	1	2	3	4	5	6	7	8
Description	TX+	TX-	RX+	N/C	N/C	RX-	N/C	N/C

## A.7 <PS/2 Keyboard & Mouse Port>

Connector: **J19 (keyboard)**

Type: 6-pin Mini-DIN connector on bracket

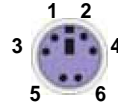

Pin	1	2	3	4	5	6
Description	N/C	KB_CK	BVCC	IOGND	N/C	KB_DT

Connector: **J19 (Mouse)**

Type: 6-pin Mini-DIN connector on bracket

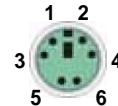

Pin	1	2	3	4	5	6
Description	N/C	MS_CK	BVCC	IOGND	N/C	MS_DT

## A.8 <CPU Voltage>

Connector : **J14**

Type: Setting CPU Voltage

CPU	Frequency	Jumpsetting	Voltage
NX1250@6W	667MHz	8818888	1.1V
NX1500@6W	1.0GHz	8880888	1.0V
NX1750@14W	1.4GHz	8118888	1.25V

## A.9 < USB Interface >

Connector: **J3**

Type: 10-pin (5 x 2) header for dual USB Ports



Pin	Description	Pin	Description
1	VCC	2	VCC
3	Data0-	4	Data1-
5	Data0+	6	Data1+
7	Ground	8	Ground
9	Ground	10	NC

(This Page is Left for Blank)

## Appendix B <Flash BIOS>

### B.1 BIOS Auto Flash Tool

The board is based on Award BIOS and can be updated easily by the BIOS auto flash tool. You can download the tool online at the address below:

<http://www.award.com>

File name of the tool is "awdf flash.exe", it's the utility that can write the data into the BIOS flash ship and update the BIOS.

### B.2 Flash Method

1. Please make a bootable floppy disk.
2. Get the last .bin files you want to update and copy it into the disk.
3. Copy awardflash.exe to the disk.
4. Power on the system and flash the BIOS. (Example: C:/ awardflash XXX.bin)
5. Re-star the system.

(This Page is Left for Blank)

## Appendix C <System Resources>

### C.1 <I/O Port address Map>

[00000000 - 0000000F]	Direct memory access controller
[00000000 - 00000CF7]	PCI bus
[00000010 - 0000001F]	Motherboard resources
[00000020 - 00000021]	Programmable interrupt controller
[00000022 - 0000003F]	Motherboard resources
[00000040 - 00000043]	System timer
[00000044 - 0000005F]	Motherboard resources
[00000060 - 00000060]	Standard 101/102-Key or Microsoft Natural PS/2 Keyboard
[00000061 - 00000061]	System speaker
[00000062 - 00000063]	Motherboard resources
[00000064 - 00000064]	Standard 101/102-Key or Microsoft Natural PS/2 Keyboard
[00000065 - 0000006F]	Motherboard resources
[00000070 - 00000073]	System CMOS/real time clock
[00000074 - 0000007F]	Motherboard resources
[00000080 - 00000090]	Direct memory access controller
[00000091 - 00000093]	Motherboard resources
[00000094 - 0000009F]	Direct memory access controller
[000000A0 - 000000A1]	Programmable interrupt controller
[000000A2 - 000000BF]	Motherboard resources
[000000C0 - 000000DF]	Direct memory access controller
[000000E0 - 000000EF]	Motherboard resources
[000000F0 - 000000FF]	Numeric data processor
[000001F0 - 000001F7]	Primary IDE Channel
[00000274 - 00000277]	ISAPNP Read Data Port
[00000279 - 00000279]	ISAPNP Read Data Port
[00000290 - 00000297]	Motherboard resources
[000002F8 - 000002FF]	Built-in Infrared Device
[00000378 - 0000037F]	Printer Port (LPT1)
[000003B0 - 000003BB]	VIA CPU to AGP2.0/AGP3.0 Controller
[000003B0 - 000003BB]	VIA/53G KM400/KN400
[000003C0 - 000003DF]	VIA CPU to AGP2.0/AGP3.0 Controller
[000003C0 - 000003DF]	VIA/53G KM400/KN400
[000003F6 - 000003F6]	Primary IDE Channel
[000003F8 - 000003FF]	Communications Port (COM1)
[000004D0 - 000004D1]	Motherboard resources
[00000778 - 0000077B]	Printer Port (LPT1)

---

[00000A79 - 00000A79]	ISAPNP Read Data Port
[00000D00 - 0000FFFF]	PCI bus
[00004000 - 0000407F]	Motherboard resources
[00005000 - 0000500F]	Motherboard resources
[0000D000 - 0000D0FF]	VIA SATA RAID Controller
[0000D400 - 0000D4FF]	Realtek AC'97 Audio for VIA (R) Audio Controller
[0000D800 - 0000D8FF]	VIA Rhine II Fast Ethernet Adapter
[0000DC00 - 0000DC03]	VIA SATA RAID Controller
[0000DD00 - 0000DD0F]	VIA SATA RAID Controller
[0000DE00 - 0000DE07]	VIA SATA RAID Controller
[0000DF00 - 0000DF0F]	VIA Bus Master IDE Controller
[0000E000 - 0000E01F]	VIA Rev 5 or later USB Universal Host Controller
[0000E100 - 0000E11F]	VIA Rev 5 or later USB Universal Host Controller
[0000E200 - 0000E21F]	VIA Rev 5 or later USB Universal Host Controller
[0000E300 - 0000E31F]	VIA Rev 5 or later USB Universal Host Controller
[0000E400 - 0000E403]	VIA SATA RAID Controller
[0000E500 - 0000E507]	VIA SATA RAID Controller



## C.2 <Memory Address Map>

[00000000 - 0009FFFF]	System board
[000A0000 - 000BFFFF]	PCI bus
[000A0000 - 000BFFFF]	VIA CPU to AGP2.0/AGP3.0 Controller
[000A0000 - 000BFFFF]	VIA/S3G KM400/KN400
[000C0000 - 000DFFFF]	PCI bus
[000CDA00 - 000CFFFF]	System board
[000F0000 - 000F7FFF]	System board
[000F8000 - 000FBFFF]	System board
[000FC000 - 000FFFFF]	System board
[00100000 - 3BEDFFFF]	System board
[3BEE0000 - 3BEFFFFF]	System board
[3BF00000 - FEBFFFFF]	PCI bus
[E4000000 - E7FFFFFF]	VIA CPU to AGP2.0/AGP3.0 Controller
[E8000000 - EBFFFFFF]	VIA CPU to AGP2.0/AGP3.0 Controller
[E8000000 - EBFFFFFF]	VIA/S3G KM400/KN400
[EC000000 - ECFFFFFFF]	VIA/S3G KM400/KN400
[EC000000 - EDFFFFFFF]	VIA CPU to AGP2.0/AGP3.0 Controller
[EE000000 - EE0000FF]	Standard Enhanced PCI to USB Host Controller
[EE001000 - EE0010FF]	VIA Rhine II Fast Ethernet Adapter
[FEC00000 - FEC00FFF]	System board
[FEE00000 - FEE00FFF]	System board
[FFF80000 - FFFFFFFFF]	System board
[FFFF0000 - FFFFFFFF]	System board

## C.3 <System IRQ & DMA Resource>

### C.3.1 <IRQ>

- (ISA) 0 System timer
- (ISA) 1 Standard 101/102-Key or Microsoft Natural PS/2 Keyboard
- (ISA) 3 Built-in Infrared Device
- (ISA) 4 Communications Port (COM1)
- (ISA) 8 System CMOS/real time clock
- (ISA) 9 Microsoft ACPI-Compliant System
- (ISA) 12 PS/2 Compatible Mouse
- (ISA) 13 Numeric data processor
- (ISA) 14 Primary IDE Channel
- (PCI) 16 VIA/S3G KM400/KN400
- (PCI) 20 VIA SATA RAID Controller
- (PCI) 21 Standard Enhanced PCI to USB Host Controller
- (PCI) 21 VIA Rev 5 or later USB Universal Host Controller
- (PCI) 21 VIA Rev 5 or later USB Universal Host Controller
- (PCI) 21 VIA Rev 5 or later USB Universal Host Controller
- (PCI) 21 VIA Rev 5 or later USB Universal Host Controller
- (PCI) 22 Realtek AC'97 Audio for VIA (R) Audio Controller
- (PCI) 23 VIA Rhine II Fast Ethernet Adapter

### <DMA>

- 4 Direct memory access controller

---

Any advice or comments about our products and service, or anything we can help you with please don't hesitate to contact with us. We will do our best to support your products, projects and business.



Address: Global American, Inc.  
17 Hampshire Drive  
Hudson, NH 03051

Telephone: Toll Free (U.S. Only) 800-833-8999  
(603)886-3900

FAX: (603)886-4545

Website: <http://www.globalamericaninc.com>

E-Mail: [salesinfo@globalamericaninc.com](mailto:salesinfo@globalamericaninc.com)

---