



User's Manual

3301520

Preface

Regulatory Compliance Statements

This section provides the FCC compliance statement for Class A devices and describes how to keep the system CE compliant.

Federal Communications Commission (FCC) For Class A Device

This equipment has been tested and verified to comply with the limits for a Class A digital device, pursuant to Part 15 of FCC Rules. These limits are designed to provide reasonable protection against harmful interference when the equipment is operated in a commercial environment. This equipment generates, uses, and can radiate radio frequency energy and, if not installed and used in accordance with the instructions, may cause harmful interference to radio communications. Operation of this equipment in a residential area (domestic environment) is likely to cause harmful interference, in which case the user will be required to correct the interference (take adequate measures) at their own expense.

Preface

CE Certification

The product(s) described in this manual complies with all applicable European Union (CE) directives if it has a CE marking. For computer systems to remain CE compliant, only CE-compliant parts may be used. Maintaining CE compliance also requires proper cable and cabling techniques.

WARNINGS

Read and adhere to all warnings, cautions, and notices in this guide and the documentation supplied with the chassis, power supply, and accessory modules. If the instructions for the chassis and power supply are inconsistent with these instructions or the instructions for accessory modules, contact the supplier to find out how you can ensure that your computer meets safety and regulatory requirements.

CAUTION

Electrostatic discharge (ESD) can damage NSA components. Do the described procedures only at an ESD workstation. If no such station is available, you can provide some ESD protection by wearing an antistatic wrist strap and attaching it to a metal part of the computer chassis.

Safety Information

Before installing and using the 3301520, note the following precautions:

- f* Read all instructions carefully.
- f* Do not place the unit on an unstable surface, cart, or stand.
- f* Follow all warnings and cautions in this manual.
- f* When replacing parts, ensure that your service technician uses parts specified by the manufacturer.
- f* Avoid using the system near water, in direct sunlight, or near a hearing device.

Table of Content

Preface	1
Copyright	1
Disclaimer	1
Acknowledgements	1
Regulatory Compliance Statements	1
Federal Communications Commission (FCC) For Class A Device	1
CE Certification	2
Safety Information	2
Table of Content	3
Chapter 1 General Information	
1.1 Main Feature.....	6
1.2 Specifications.....	6
1.3 Power Consumption Measurement.....	9
1.4 Board Layout.....	10
1.5 Board Dimensions.....	12
Chapter 2 Jumper Setting	
2.1 Before You Begin.....	13
2.2 Precautions.....	13
2.3 Setting Jumpers.....	14
2.4 Location of Jumpers.....	15
2.5 Function of Jumper.....	17
2.6 Connector and Pin Definition.....	18
Chapter 3 Expansion	
3.1 System Memory.....	33
3.2 Installing DIMM.....	34
3.3 Installing Compact Flash.....	36
3.4 Installing Intel Pentium-M CPU and Fan Heatsink.....	37

This Page is Left Blank Intentionally

Chapter 1

General Information

1.1 Main Feature

Support socket LGA775 Intel® Pentium 4/Pentium D/Celeron D Processors with 533/800 MHz FSB, speed up to 3.8GHz

- Intel® 945G and ICH-7R chipsets
- 240-pin DIMM x 2, support dual channel DDR2 533/667 up to 2 GB
- Intel® PC82573L PCI Express Gigabit Ethernet Controller x 2 supporting two GbE LAN ports (PEAK870VL2)
- Shared integrated graphics controller from chipset with 2048 x 1536 resolution @ 85 Hz
- Support IDE and SATA HDD
- USB 2.0 Port x 8, COM x 2
- Support Disk on Module

1.2 Specifications

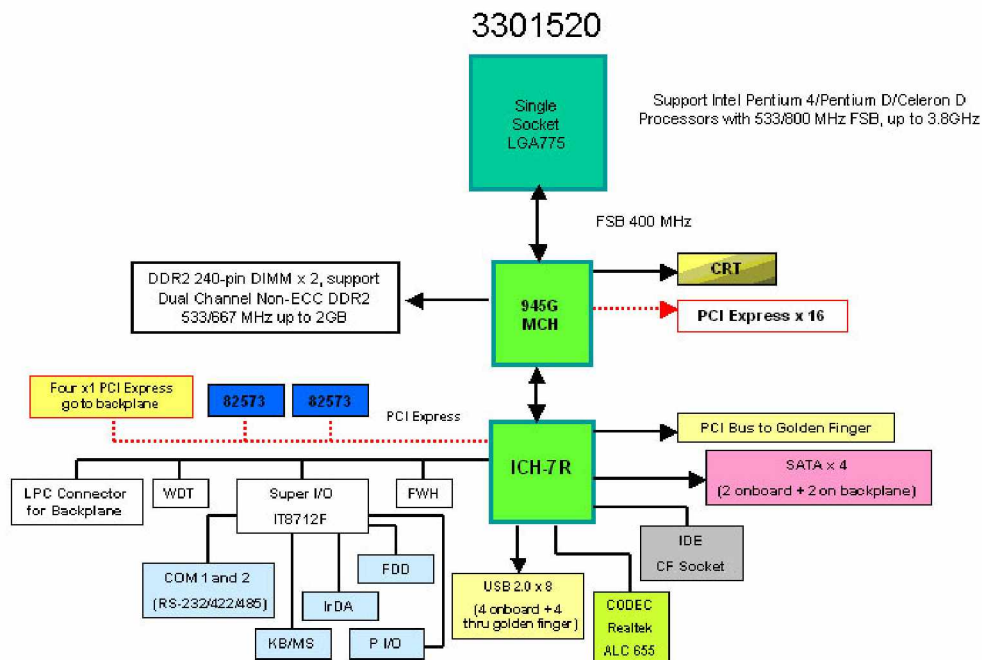

Figure 1.1: Block Diagram of 3301520

System Architecture	- PICMG 1.3 Socket LGA775 Full-Sized SBC
CPU Support	<ul style="list-style-type: none"> - Single socket LGA 775 - Support Intel® Pentium 4 and 65nm Cedar Mill Intel® Pentium 4m with 533/800 MHz FSB, speed up to 3.8GHz - Support Intel® Celeron D with 533MHz FSB - Support Intel® Pentium D with 800 MHz FSB - Support Hyper-Threading Technology
Memory	<ul style="list-style-type: none"> - Intel Non-ECC DDR2 533/667 MHz, up to 2 GHz
BIOS	<ul style="list-style-type: none"> - Award System BIOS - Plug & Play Support - Advanced Power Management and Advanced Configuration & Power Interface support
Chipset	<ul style="list-style-type: none"> - Intel® 945G - Intel® ICH-7R
LAN	<ul style="list-style-type: none"> - Intel® PC82573L PCI Express Gigabit Ethernet Controller x 2 supporting two GbE LAN ports - Supporting Boot from LAN
Display	<ul style="list-style-type: none"> - Share integrated Graphics controller from 945G chipset - Analogue Display Support: Up to 2048 x 1536 @ 85 Hz for CRT - VGA DB-15 connector x 1

- Serial port: 10-pin box header x 2 (COM 2 reserved for RS-422/485 as an option)
- Disk on Module: 2-pin power connector for DOM
- USB: Eight USB2.0 ports with 480Mb/s bandwidth (4 on Board, 4 to Backplane)
- IDE HDD: Ultra ATA100/66/33, 40 pin connector x 1
- SATA HDD: 4 Serial ATA II Ports, bandwidth: 300 MB/s (2 onboard and 2 to backplane)
- GPIO: Support 4 sets general purpose I/O each with TTL level (5V) interface

I/O Interface

- Parallel port: 26-pin connector x 1
- Floppy: 34-pin connector x 1
- On board buzzer x 1
- On board 2-pin header for reset
- AC' 97 Audio Codec, Realtek ALC655 (4 pin for Mic in, 4 pin for Line in, and 4 pin for line out)
- 2-pin power-on button switch
- 2-pin header for SMBus 2.0 Controller
- 4-pin FAN JST connector x 1 (For CPU); 3-pin FAN connector x 2
- 5-pin for key lock/power LED/HDD Power LED
- 5-pin connector x 1 for Chassis or Backplane Front KB/ Mouse
- VGA DB-15 connector x 1

I/O on Bracket

- RJ45 Gigabit Ethernet LAN port x 2
- Mini-DIN PS/2 Keyboard/mouse x 1

◁ Power source

- ¾ Power source from Backplane through Golden Finger
- ¾ Support both ATX or BTX Power Supply
- ¾ 4 Pins +12V Power Input Connector

Power Supply

◁ Power requirement (Max. Design Power, base on P4 3.8GHZ)

- ¾ 5V: 18A
- ¾ 12V: 20A
- ¾ 3.3V: 5A
- ¾ 5Vsb: 2A

◁ System monitor controller from Super I/O

- ◁ 8 voltage (For +1.5V, +3.3V, +5V, +12V, +1.8V, Vcore and +5VSTBY and +3VSTBY)

System Management

- ◁ 2 temperature (For CPU and system)

3 FAN speed monitor (one for CPU and 2 for systems)

Real Time Clock

- On-chip RTC with battery back up

	- External Lithium battery x 1
Watchdog Timer	- 1-minute increments from 1 to 255 minutes - 1-second increments from 1 to 255 seconds
Dimensions	- 338.58mm (L) x 126.39mm (W)
Environments	- Board-level operating temperatures: 0°C to 60°C - Storage temperatures: -20°C to 80°C - Relative humidity: 10% to 90% (Non-condensing)
Certification	- CE - FCC Class A

Ordering Information

3301520 (LF)

RoHS Compliance

NEW

PICMG 1.3 Full-Size SHB, Intel 945G Chipset, LGA775 P4 CPU up to 3.8GHz, 533/800MHz FSB, Dual Core Pentium D support.

Max. 2GB DDR2 400 DIMM, VGA integrated , Intel 82573L PCI Express Gigabit Ethernet x 2, Serial ATA Ports x 4

1.3 Power Consumption Measurement

Required watts and currents for Power Supply

Power Type	+12V	+5V	+5VSB
Consumed watts (Item: W)	N/A	N/A	N/A
Consumed currents (Item A)	N/A	N/A	N/A
Actually required currents (Item A/0.8)	N/A	N/A	N/A

1.4 Board Layout

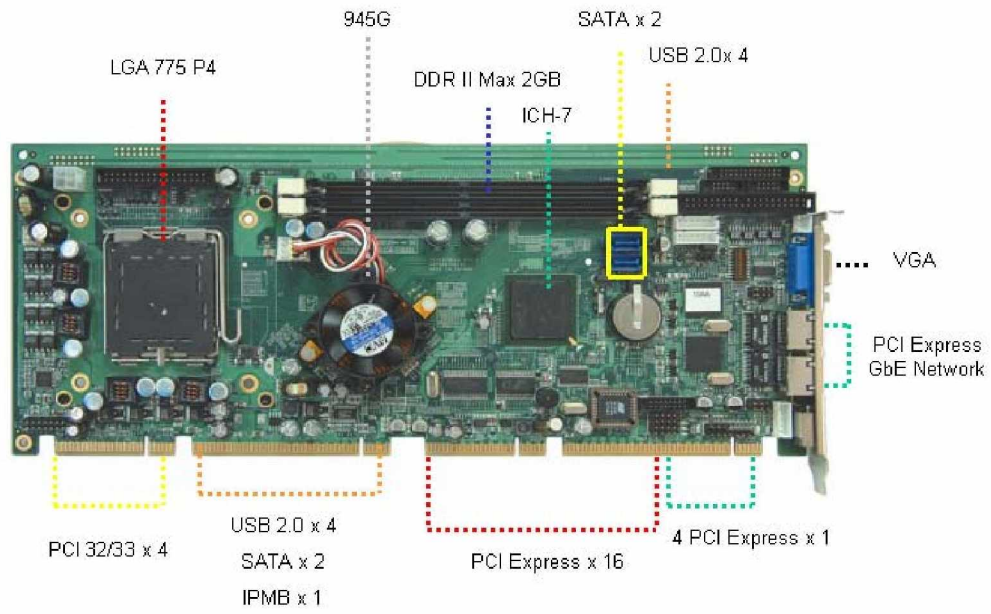

Figure 1.2: Overview of 3301520

1.5 Board Dimensions

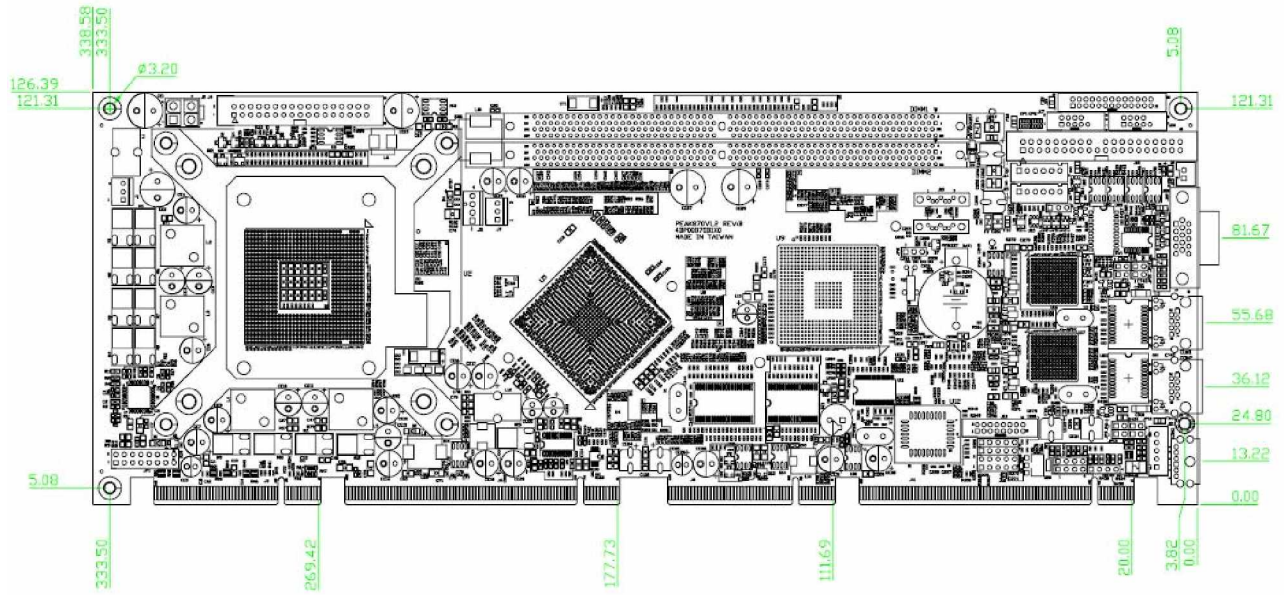

Figure 1.3: Mechanical Drawing of the 3301520

Chapter 2

Jumper Setting

This chapter of the User's Manual describes how to set jumpers.

Note: The procedures that follow are generic for all 3301520 series.

2.1 Before You Begin

Ensure you have a stable, clean working environment. Dust and dirt can get into components and cause a malfunction. Use containers to keep small components separated.

Adequate lighting and proper tools can prevent you from accidentally damaging the internal components. Most of the procedures that follow require only a few simple tools, including the following:

- ◆ A Philips screwdriver
- ◆ A flat-tipped screwdriver
- ◆ A set of jewelers Screwdrivers
- ◆ A grounding strap
- ◆ An anti-static pad

Using your fingers can disconnect most of the connections. It is recommended that you do not use needle-nosed pliers to disconnect connections as these can damage the soft metal or plastic parts of the connectors.

Before working on internal components, make sure that the power is off. Ground yourself before touching any internal components, by touching a metal object. Static electricity can damage many of the electronic components. Humid environment tend to have less static electricity than dry environments. A grounding strap is warranted whenever danger of static electricity exists.

2.2 Precautions

Computer components and electronic circuit boards can be damaged by discharges of static electricity. Working on the computers that are still connected to a power supply can be extremely dangerous. Follow the guidelines below to avoid damage to your computer or yourself:

- ◆ Always disconnect the unit from the power outlet whenever you are working inside the case.
- ◆ If possible, wear a grounded wrist strap when you are working inside the computer case. Alternatively, discharge any static electricity by touching the bare metal chassis of the unit case, or the bare metal body of any other grounded appliance.
- ◆ Hold electronic circuit boards (such as the 3301520 board) by the edges only. Do not touch the components on the board unless it is necessary to do so. Don't flex or stress the circuit board.
- ◆ Leave all components inside the static-proof packaging that they shipped with until they are ready for installation.
- ◆ Use correct screws and do not over tighten screws.

2.3 Setting Jumpers

A jumper is the simplest kind of electric switch. It consists of two metal pins and a cap. When setting the jumpers, ensure that the jumper caps are placed on the correct pins. When the jumper cap is placed on both pins, the jumper is **SHORT**. If you remove the jumper cap, or place the jumper cap on just one pin, the jumper is **OPEN**. Please see the following illustrations

<p>The illustrations on the right show a 2-pin jumper. When the jumper cap is placed on both pins, the jumper is SHORT. If you remove the jumper cap, or place the jumper cap on just one pin, the jumper is OPEN.</p>		
<p>These illustrations show a 3-pin jumper. Pins 1 and 2 are SHORT.</p>		

Table 2-1: Setting Jumpers

2.4 Location of Jumpers (Rev: B)

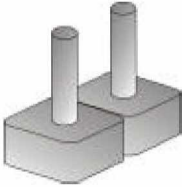
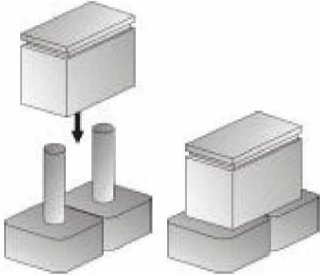
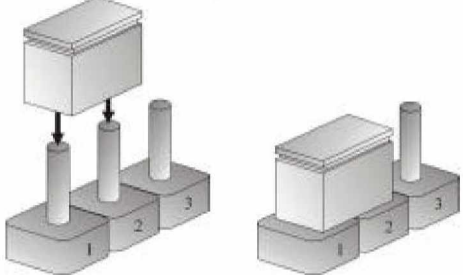
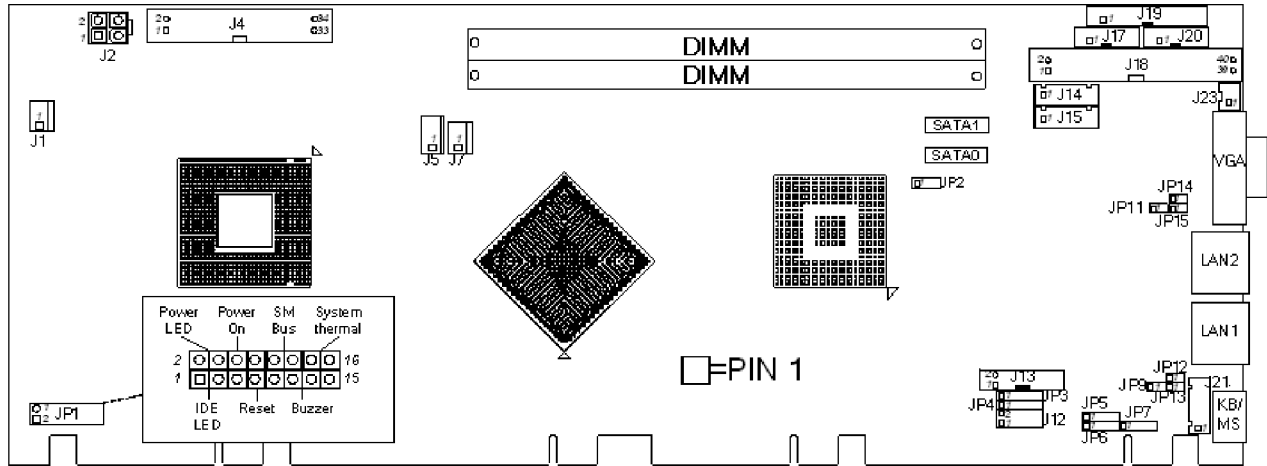

Figure 2-1: Jumper Location

Switch setting table (*: default setup)

COM Port Type Select

SW1	1-20	2-19	3-18	4-17	5-16	6-15	7-14	8-13	9-12	10-11
*RS232	OFF	OFF	OFF	ON	OFF	ON	OFF	OFF	OFF	OFF
RS422	OFF	ON	ON	OFF	ON	OFF	ON	ON	ON	ON
RS485	ON	ON	OFF	ON	ON	OFF	OFF	OFF	OFF	ON

RTC Clear

	Normal	Clear CMOS
JP2	*1-2	2-3

CF Card Master/Slave Select

	Slave	Master
J16	1-2	*2-3

Connector Define

Connector	Function	NOTE
J1	System FAN 2	
J2	AUX +12V Power	
J4	Floppy	
J5	CPU FAN	
J7	System FAN 1	
J9	SATA 0	
J10	SATA 1	
J12	GPIO	
J13	External LPC connector	
J14	USB 0/1	
J15	USB 2/3	
J17	COM 2	
J18	Primary IDE	
J19	PIO	
J20	COM 1	
J21	External keyboard	
J22	VGA connector	
J23	Disk on module external power	
J24	CF card socket	
JP1	IDE LED / Power LED / Power ON / Reset / Buzzer/SM Bus/ System Thermal	
JP3	IR	
JP4	Keyboard lock	
JP5	Line out	
JP6	Line in	
JP7	MIC in	
JP9	82573L LAN1 Link 1000 LED	
JP11	82573L LAN2 Link 1000 LED	
JP12	82573L LAN1 Activity LED	
JP13	82573L LAN1 Link 100 LED	
JP14	82573L LAN2 Activity LED	
JP15	82573L LAN2 Link 100 LED	
CON1	82573L LAN2 Connector	
CON2	82573L LAN1 Connector	
CON3	Keyboard + mouse Connector	

Pin definitions of connectors

J1/J7: System FAN 2/ System FAN 1

Pin	Definition	Pin	Definition
1	GND	3	Sense
2	+12V		

J2: AUX +12V Power

Pin	Definition	Pin	Definition
1	GND	3	+12V
2	GND	4	+12V

J4: Floppy

Pin	Definition	Pin	Definition
1	GND	18	DIR#
2	DENSEL#	19	GND
3	GND	20	STEP#
4	NC	21	GND
5	GND	22	Write Data#
6	NC	23	GND
7	GND	24	WGATE#
8	INDEX#	25	GND
9	GND	26	TK00#
10	MOTEA#	27	GND
11	GND	28	WPT#
12	DRVB#	29	GND
13	GND	30	Read Data#
14	DRVA#	31	GND
15	GND	32	SIDE1#
16	MOTEB#	33	GND
17	GND	34	DSKCHG#

J5: CPU FAN

Pin	Definition	Pin	Definition
1	GND	3	Sense
2	+12V	4	NC

J9/J10/ : SATA0/SATA 1

Pin	Definition	Pin	Definition
1	GND	5	SATA_RXN
2	SATA_TXP	6	SATA_RXP
3	SATA_TXN	7	GND
4	GND		

J12: GPIO

Pin	Definition	Pin	Definition
1	+5V	6	GP25_D_IN1(PIN25)
2	GND	7	GP22_D_OUT2(PIN22)
3	GP20_D_OUT0(PIN20)	8	GP26_D_IN2(PIN26)
4	GP24_D_IN0(PIN24)	9	GP23_D_OUT3(PIN23)
5	GP21_D_OUT1(PIN21)	10	GP27_D_IN3(PIN27)

J13: External LPC connector

Pin	Definition	Pin	Definition
1	ISA 14 MHZ	9	GND
2	GND	10	LPC DRQ#
3	LPC FRAME#	11	+3.3V
4	GND	12	Series IRQ
5	LPC Address 3	13	+3.3V
6	LPC Address 2	14	Reset#
7	LPC Address 1	15	GND
8	LPC Address 0	16	PCI 33MHZ

J14: USB 0/1

Pin	Definition	Pin	Definition
1	+5VSB	4	Data 1-
2	Data 0-	5	Data 1+
3	Data 0+	6	GND

J15: USB 2/3

Pin	Definition	Pin	Definition
1	+5VSB	4	Data 3-
2	Data 2-	5	Data 3+
3	Data 2+	6	GND

J17/J20: COM2/COM1

Pin	Definition	Pin	Definition
1	DCD	6	DSR
2	RXD	7	RTS
3	TXD	8	CTS
4	DTR	9	RI
5	GND	10	NC

J18: Primary IDE

Pin	Definition	Pin	Definition
1	Reset#	21	DMA REQ
2	GND	22	GND
3	Data 7	23	IOW#
4	Data 8	24	GND
5	Data 6	25	IOR#
6	Data 9	26	GND
7	Data 5	27	IOCHRDY
8	Data 10	28	GND
9	Data 4	29	DMA ACK#
10	Data 11	30	GND
11	Data 3	31	Interrupt
12	Data 12	32	NC
13	Data 2	33	DiskAddress 1
14	Data 13	34	DMA66 Detect
15	Data 1	35	DiskAddress 0
16	Data 14	36	DiskAddress 2
17	Data 0	37	HDCCS1#
18	Data 15	38	HDCCS3#
19	GND	39	HDD Active #
20	NC	40	GND

J19: PIO

Pin	Definition	Pin	Definition
1	Line Print Strobe	14	Auto Feed#
2	Parallel Data 0	15	Error#
3	Parallel Data 1	16	Initialize#
4	Parallel Data 2	17	Select Input#
5	Parallel Data 3	18	GND
6	Parallel Data 4	19	GND
7	Parallel Data 5	20	GND
8	Parallel Data 6	21	GND
9	Parallel Data 7	22	GND
10	Acknowledge#	23	GND
11	Busy	24	GND
12	Paper empty	25	GND
13	Select	26	NC

J21 : External keyboard

Pin	Definition	Pin	Definition
1	Keyboard Clock	4	GND
2	Keyboard Data	5	+5V
3	NC		

J22: VGA connector

Pin	Definition	Pin	Definition
1	Red	9	+5V
2	Green	10	GND
3	Blue	11	NC
4	NC	12	DDC Data
5	GND	13	HSYNC
6	GND	14	VSYNC
7	GND	15	DDC Clock
8	GND		

J23: Disk on module external power

Pin	Definition	Pin	Definition
1	+5V	2	GND

J24: CF card socket

Pin	Definition	Pin	Definition
1	GND	26	GND
2	Data 3	27	Data 11
3	Data 4	28	Data 12
4	Data 5	29	Data 13
5	Data 6	30	Data 14
6	Data 7	31	Data 15
7	HDCCS1#	32	HDCCS3#
8	GND	33	N/C
9	GND	34	IOR#
10	GND	35	IOW#
11	GND	36	+5V
12	GND	37	Interrupt
13	+5V	38	+5V
14	GND	39	CF_CSEL#
15	GND	40	NC
16	GND	41	Reset#
17	GND	42	IOCHRDY
18	Disk Address 2	43	DMA REQ
19	Disk Address 1	44	DMA ACK#
20	Disk Address 0	45	HDD Active#
21	Data 0	46	DMA66 Dectec
22	Data 1	47	Data 8
23	Data 2	48	Data 9
24	NC	49	Data 10
25	GND	50	GND

JP1: IDE LED/Power LED/Power ON/Reset/Buzzer/SM BUS/System Thermal

Pin	Definition	Pin	Definition
1	+5V	9	+5V
2	+5V	10	SMB_ Data
3	IDE_LED	11	GND
4	GND	12	SMB_ Clock
5	Power ON	13	GND
6	GND	14	Thermal Pin
7	Reset	15	Speaker
8	GND	16	Thermal GND

 : PIN1

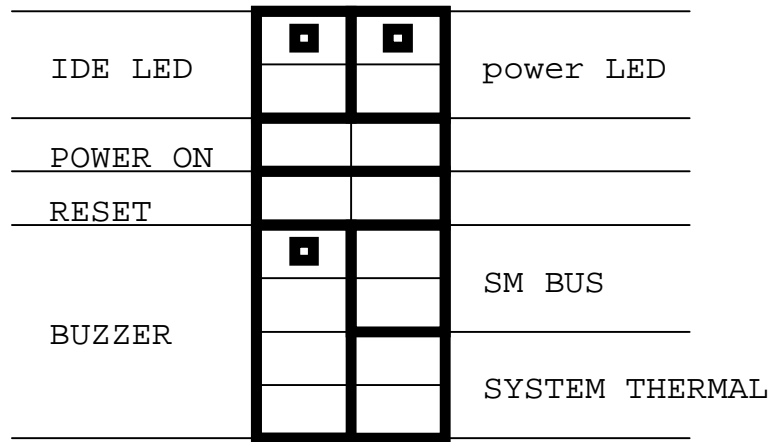

JP3: IR

Pin	Definition	Pin	Definition
1	+5V	4	GND
2	CIRRX	5	IRTX
3	IRRX		

JP4: Keyboard lock

Pin	Definition	Pin	Definition
1	+5V	4	Keyboard Lock
2	NC	5	GND
3	GND		

JP5: Line-out

Pin	Definition	Pin	Definition
1	LINEOUT_L	3	JD1
2	GND	4	LINEOUT_R

JP6: Line-in

Pin	Definition	Pin	Definition
1	LINEIN_L	3	JD2
2	GND	4	LINEIN_R

JP7: MIC-in

Pin	Definition	Pin	Definition
1	MICIN2	3	JD0
2	GND JD0	4	MICIN1

JP9/JP11: 82573L LAN1 LINK1000 LED / 82573L LAN2 LINK1000 LED

Pin	Definition	Pin	Definition
1	Speed100#	2	Speed1000#

JP12/JP14: 82573L LAN1 Activity LED / 82573L LAN2 Activity LED

Pin	Definition	Pin	Definition
1	Activity#	2	+3.3VSB

JP13/JP15: 82573L LAN1 LINK100 LED / 82573L LAN2 LINK100 LED

Pin	Definition	Pin	Definition
1	Speed1000#	2	Speed100#

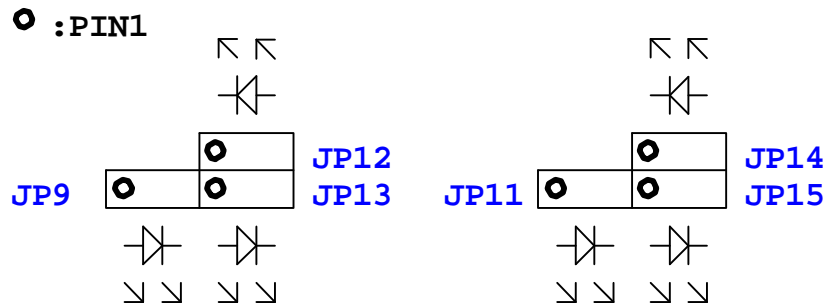

CON1/CON2: 82573L LAN2 Connector/82573L LAN1 Connector

Pin	Definition	Pin	Definition
1	MDI0P	7	MDI3P
2	MDI0N	8	MDI3N
3	MDI1P	9	ACTIVITY#
4	MDI2P	10	+5VSB

5	MDI2N	11	LINK100#
6	MDI1N	12	LINK1000#

CON3: Key board + mouse Connector

Pin	Definition	Pin	Definition
1	Mouse Data	4	Keyboard Clock
2	Keyboard Data	5	+5VSB
3	Mouse Clock	6	GND

Chapter 3

Expansion

3.1 System Memory

3301520 incorporates Intel 945G chipset supports dual channel non-ECC un-buffered DDR2 533/667 MHz memory up to 2GB. Two 240-pins DIMM sockets support up to a maximum 2GB DIMM.

Followings are the recommended memory modules.

Size (MB)	Technology Type	Vendor	Remark
512MB	DDRII 533, 240 PIN, non ECC	A-DATA	*2PCS
512MB	DDRII 533,240 PIN, non ECC	UNIGEN	*2PCS
1GB	DDRII 533,240 PIN, non ECC	UNIGEN	*4PCS
1GB	DDRII 533,240 PIN, non ECC	APACER	*4PCS

Table 3.1: Recommended Memory Modules

3.2 Installing DIMM

To install DIMM

1. Make sure the two handles of the DIMM sockets are in the “open” position, i.e. the handles stay outward.

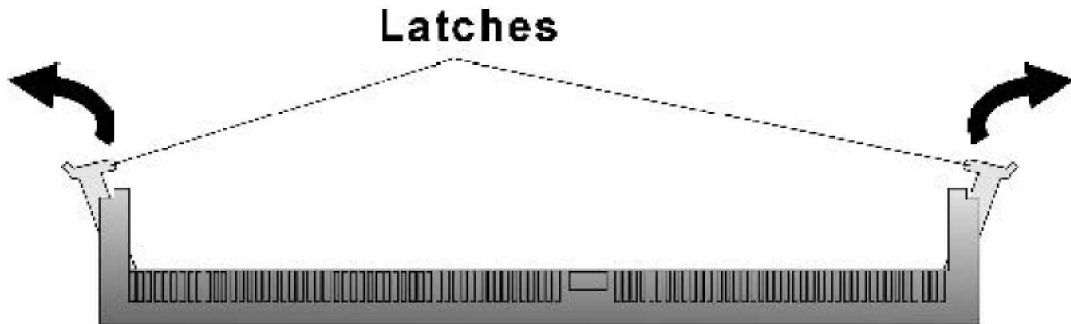

Figure3-1: How to Install DIMM (1)

2. Slowly slide the DIMM modules along the plastic guides in the both ends of the socket.

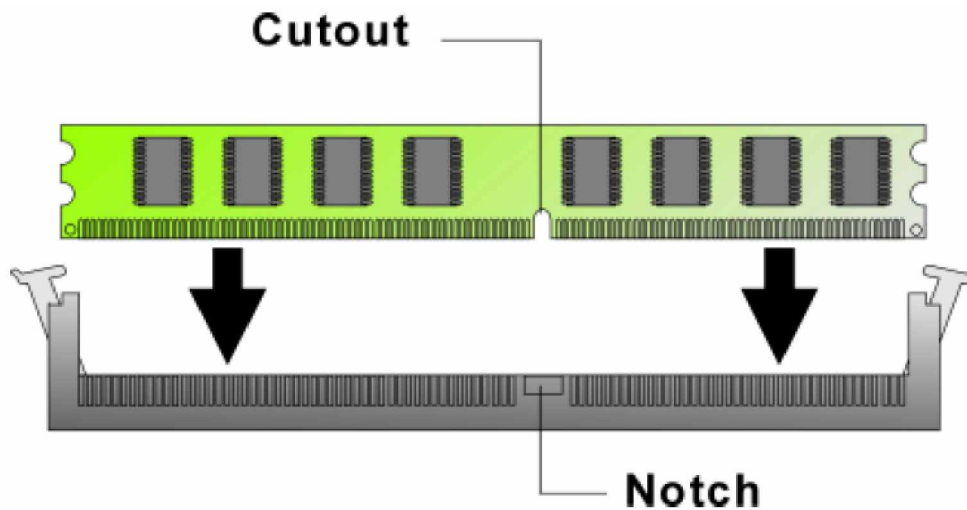

Figure 3-2: How to Install DIMM (2)

3. Then press the DIMM module down right into the socket, until a click is heard. That means the two handles automatically locked the memory modules into the right position of the DIMM socket.

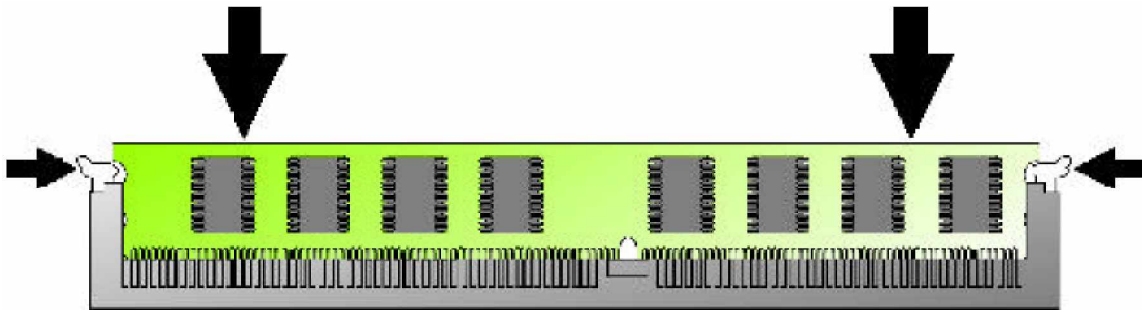

Figure 3-3: How to Install DIMM (3)

4. To take away the memory module, just push the both handles outward, the memory module will be ejected by the mechanism in the socket.

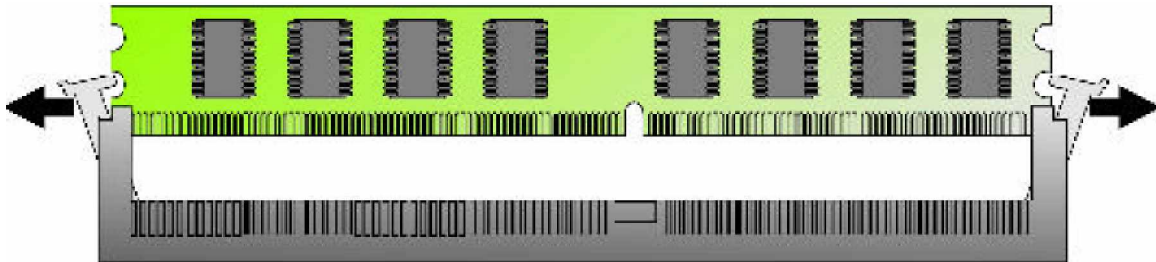

Figure 3-4: How to Install DIMM (4)

3.3 Installing Compact Flash (Skip – No CF with Standard 3301520)

1. To install a Compact Flash memory card into PAEK 870, align the notches on the card with the Compact Flash socket in the 3301520. Then firmly insert the card into the socket until it is completely seated.

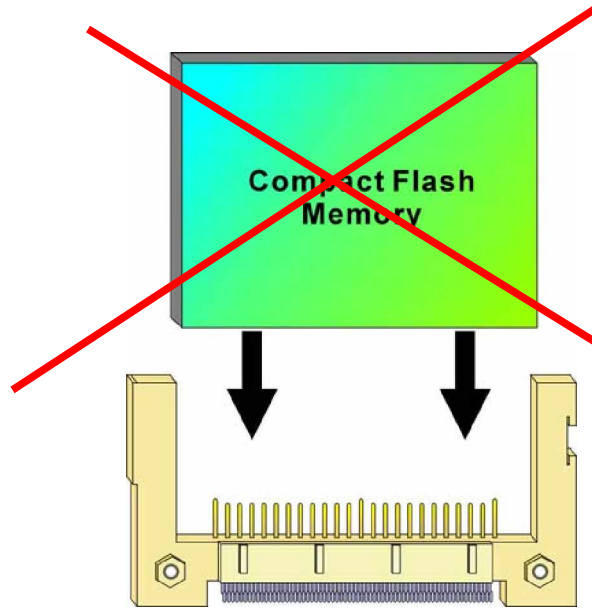

Figure 3-5: How to Install Compact Flash Memory (1)

2. To remove the Compact Flash memory card from 3301520, pull out the memory card from the Compact Flash socket.

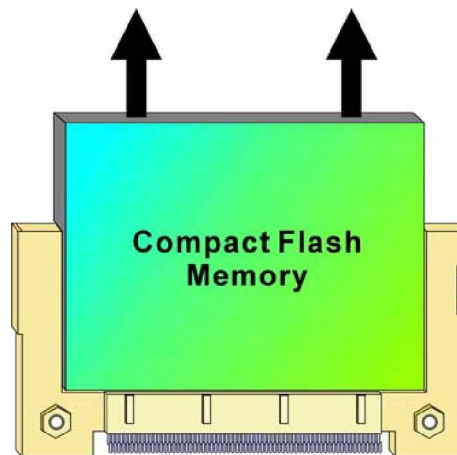

Figure 3-6: How to Uninstall Compact Flash Memory (2)

3.4 Installing socket LGA775 Intel Pentium-4 CPU, Heat Sink, and Fan

Since the socket 775 is comprised of sensitive arrays of pins, improper or careless installation may cause permanent harm to the CPU. In some cases users may accidentally damage the socket simply by adjusting the position of the CPU.

Please follow the installation instructions as shown below:

Step 1:

1. Opening the Socket:

- a. Disengage the Load Lever by pressing down and out on the hook allowing the lever to clear the Retention Tab and rotate to the fully open position.
- b. Rotate Load Plate to fully open position.
- c. Remove the Protective Cover as shown below

Caution: Touch the Socket Contacts may damage to the contacts.

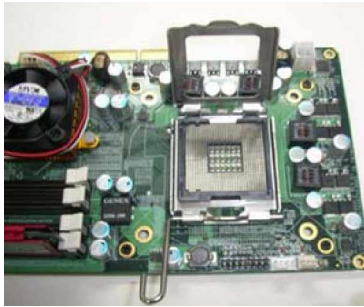

Step 2:

- a. Remove processor from shipping media by grasping substrate edges only.
- b. Grasp the processor with your thumb and forefinger on the edges with the orientation notches.
- c. Carefully place the CPU into the socket.



Step 3:

- a. Verify that the CPU is properly mated to the orientation keys.
- b. Close the upper plate, place the load lever back to the original position.



Step 4:

- a. Place the Heat Sink with Fan Set onto the four holes around the CPU socket making sure that the four screws are aligned with the holes on the 3301520.
- b. Pressing down the metal pads on the four Stand-Offs. c. Fasten the four screws.
- d. Connect the 4-pins CPU fan cable to the power connector as shown below.



Any advice or comments about our products and service, or anything we can help you with please don't hesitate to contact with us. We will do our best to support you for your products, projects and business

Global American Inc.

Address: 17 Hampshire Drive
Hudson, NH 03051

TEL: Toll Free (U.S. Only) 800-833-8999
(603) 886-3900

FAX: (603) 886-4545

Website: <http://www.globalamericaninc.com>

E-Mail: salesinfo@globalamericaninc.com

