



User's Manual

3301610

Acknowledgments

Award is a registered trademark of Award Software International, Inc.

PS/2 is a trademark of International Business Machines Corporation.

Intel and Pentium 4 are registered trademarks of Intel Corporation.

Microsoft Windows is a registered trademark of Microsoft Corporation.

Winbond is a registered trademark of Winbond Electronics Corporation.

All other product names or trademarks are properties of their respective owners.

Table of Contents

Introduction	1
Checklist.....	1
Product Description.....	2
Specifications	3
Board Dimensions	4
Installations	5
Installing the CPU	6
ATX Power Installation	7
Installing the Memory	7
Setting the Jumpers	8
Connectors on 3301610.....	12
Watchdog Timer Configuration	23
Digital I/O Sample Code	27
BIOS Setup.....	30
Drivers Installation	55
Intel i915G Chipset Software Installation Utility.....	56
VGA Drivers Installation	58
Realtek AC97 Codec Audio Driver Installation.....	59
Intel PRO LAN Drivers Installation.....	60
Marvell LAN Controller Drivers Installation.....	61

ATTENTION:

It is strongly recommended that only heatsinks that have corresponding (metal) backplates are used on the CPU card. This is to avoid the CPU card being bent/distorted, causing the CPU card to become damaged. A reference picture of a backplate and heatsink that has backplate are shown below.

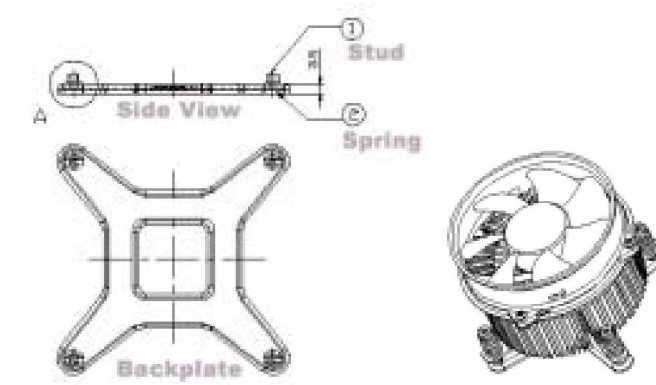

Introduction

Checklist

Your 3301610 Pentium 4 CPU card package should include the items listed below:

- The 3301610 CPU Card
- This User's Manual
- 1 IDE Ribbon Cable
- SATA Cable
- 2 Serial Port Ribbon Cable and 1 Parallel Port Attached to a Mounting Bracket
- 1 Y-Cable supporting a PS/2 Keyboard and a PS/2 Mouse
- 1 CD containing the following:
 - Chipset Drivers
 - Flash Memory Utility
- Optional audio cable with bracket
- Optional USB cable with bracket
- Optional SATA Power Cord

Product Description

The 3301610 Pentium 4 CPU card incorporates the Intel 915GV chipset that can utilize a LGA775 processor of up to 3.8GHz or higher and supports FSB frequency of 533/800Mhz (133Mhz, and 200Mhz HCLK respectively).

The 915GV chipset comes with a Graphics Memory Controller Hub (GMCH) designed for use with the Pentium 4 processor with 1MB L2 cache on 0.09 micron process. The GMCH component provides the CPU interface, DDR interface, Hub Interface, and integrated graphics with display interfaces.

Aside from CRT support, the VGA function feature a Chrontel CH7308 controller that supports dual channel LVDS

The board also has one Marvell 88E8053 PCI Express Gigabit LAN and an Intel 82551 10/100MB fast Ethernet LAN.

Other advanced features include four Serial ATA ports, four USB 2.0 ports, IrDA interface and audio function.

Specifications

Product Name	3301610
Form Factor	PICMG-1.0 (Full size CPU Card)
CPU Type	Intel Pentium 4/Celeron D, LGA775
CPU Voltage	0.8375V~1.6V (VRD 10.1)
System Speed	Up to 3.8GHz
CPU FSB	533/800MHz
Green /APM	APM1.2
CPU Socket	LGA775
Chipset	INTEL 915GV Chipset GMCH 1210-pin FCBGA ICH6 609-pin mBGA FWH
BIOS	Award BIOS, support ACPI Function
Cache	256K (Celeron D) / 1M /2MB(P4) Level 2 (CPU integrated)
VGA	915GV built-in, supports CRT
LVDS LCD Panel	Chrontel CH7308 support 18/24 bit Single or Dual channel LVDS
LAN x2	1. Intel 82551QM 10/100 LAN (upgradeable to 82541PI GbE) 2. Marvell 88E8053 PCI Express Gigabit LAN x1 (optional)
Memory type	2x DDR333/400 SDRAM DIMM module (without ECC function), Max. 2GB (Dual Channel)
USB	ICH6 built-in USB 2.0, support 4 ports
Serial ATA Ports	Supports 4 ports
Parallel IDE	ICH6 built-in; One channel Ultra DMA 33/66/100
Audio	ICH6 Built-in Sound controller + AC97 Codec ALC655 6 Channel (Line-out, Line-in, Mic.), on board header
LPC I/O	W83627HF; Parallelx1, COM1 (RS232), COM2 (RS232/422/485), Slim FDC 1.44MB, IrDA x1, Hardware monitor (3 thermal inputs, 4 voltage monitor inputs, VID0-4, 1 chassis open detection, 3 Fan Header)
PCI to ISA Bridge	Winbond 82628, 82629
IrDA (Infrared Ray)	Pin header, allows infrared wireless communication
Digital I/O	4 in/4 out, pin header
Expansion Slots	1 x Mini PCI
Edge Connector	DB15 for VGA Mini DIN for Keyboard/Mouse RJ45 x2 for Gigabit and 10/100 LAN
On Board Header/Connector	40 pins box-header x1 for IDE1 26 pins box-header x1 for Slim Floppy 26 pins box-header x1 for Printer 10 pins box-header x2 for COM1 and COM2 10 pins pin-header x1 for digital I/O 8 pins pin-header x 2 for 4 USB ports SATA connector x4 for 4 SATA ports
Watchdog Timer	Yes (256 segments, 0, 1, 2...255 sec/min)
System Voltage	+5V, +3.3V, +12V, -12V, 5VSB (2A)
Other	Modem Wakeup, LAN Wakeup, Disk On Chip
Board Size	338x122mm

Installations

This section provides information on how to use the jumpers and connectors on the 3301610 in order to set up a workable system. The topics covered are:

Installing the CPU	6
ATX Power Installation	7
Installing the Memory	7
Setting the Jumpers	8
Connectors on 3301610	12
Watchdog Timer Configuration	23
Digital I/O Sample Code	27

Installing the CPU

The 3301610 CPU card supports a LGA 775 processor socket for Intel® Pentium® 4 processors.

The LGA 775 processor socket comes with a lever to secure the processor. Refer to the pictures below, from left to right, on how to place the processor into the CPU socket. ***Please note that the cover of the LGA775 socket must always be installed during transport to avoid damage to the socket.***

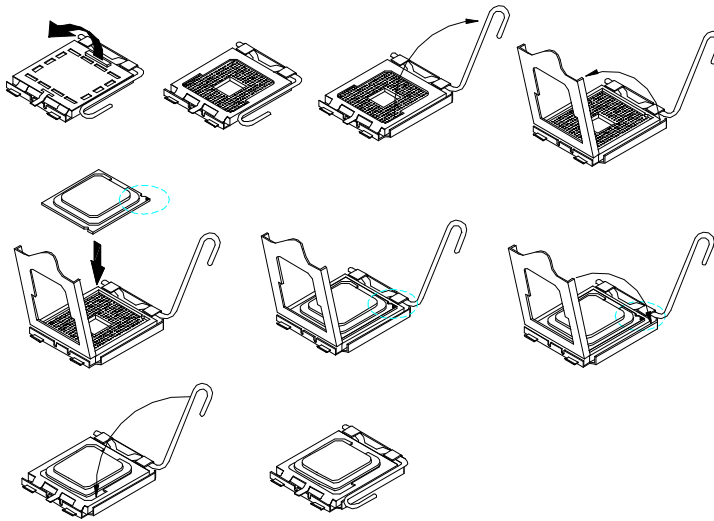

ATX Power Installation

The system power is provided to the CPU card with the CN1 and J3 ATX power connectors. Please note that the J3 external ATX power connector should be connected to the backplane for 3301610 to function. J3 is a 3-pin power connector. CN1 is a 4-pin 12V power connector. CN1 is to be connected to the ATX power supply.

Installing the Memory

The 3301610 CPU card supports two DDR memory sockets for a maximum total memory of 2GB in DDR memory type. You can install unbuffered & non-ECC DDR DIMMs. It supports DDR333 when installed with CPUs that have clock speeds of 533MHz. It supports DDR333/400 when installed with CPUs that have clock speeds of 800MHz. The board provides dual channel functionality for its DIMM slots. DDR1 is for one channel and DDR2 is for the other channel. Enabling dual channels can increase data access rates.

Basically, the system memory interface has the following features:

- Supports two 64-bit wide DDR data channels
- Available bandwidth up to 3.2GB/s (DDR400) for single-channel mode and 6.4GB/s (DDR400) in dual-channel mode.
- Supports non ECC DIMMs.
- Supports 128Mb, 256Mb, 512Mb DDR technologies.
- Supports only x8, x16, DDR devices with four banks
- Registered DIMMs not supported
- Supports opportunistic refresh
- Up to 16 simultaneously open pages (four per row, four rows maximum)

Setting the Jumpers

Jumpers are used on 3301610 to select various settings and features according to your needs and applications. Contact your supplier if you have doubts about the best configuration for your needs. The following lists the connectors on 3301610 and their respective functions.

Jumper Locations on 3301610.....	9
JP1: LVDS Panel Power Select	10
JP3: RS232/422/485 (COM2) Selection.....	10
JP4, JP5: COM1 / COM2 RS232 +5V/+12V Power Setting.....	10
JP8: Intel PCI LAN Enable/Disable	11
JP9: DiskOnChip Address Select	11
JP10: Clear CMOS Contents	11

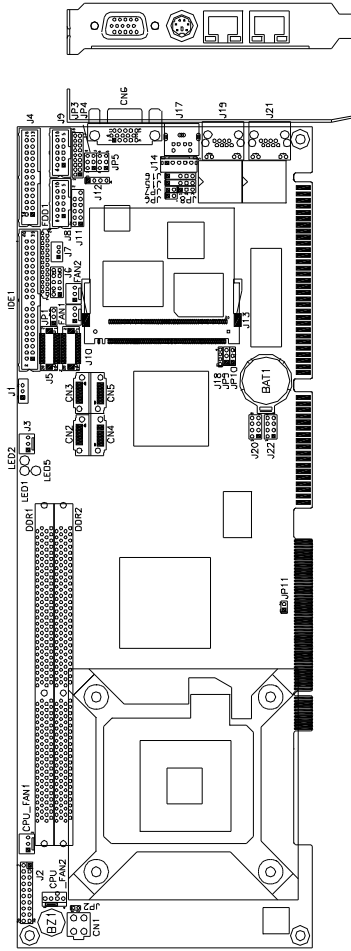

Jumper Locations on 3301610



- Jumper Locations on 3301610
- JP1: LVDS Panel Power Select
 - JP3: RS232/422/485 (COM2) Selection
 - JP4, JP5: COM1 / COM2 RS232 +5V/+12V Power Setting
 - JP8: Intel PCI LAN Enable/Disable
 - JP9: DiskOnChip Address Select ...
 - JP10: Clear CMOS Contents

Jumper Locations on 3301610

JP1: LVDS Panel Power Select

JP1	Setting	Panel Voltage
	Pin 1-2 Short/Closed	3.3V (default)
	Pin 2-3 Short/Closed	5V

JP3: RS232/422/485 (COM2) Selection

COM1 is fixed for RS-232 use only.

JP3, COM2 is selectable for RS232, RS-422 and RS-485.

The following table describes the jumper settings for COM2 selection.



COM2 Function	RS-232	RS-422	RS-485
	Jumper Setting (pin closed)	Short: 1-2 9-11 10-12 15-17 16-18	Short: 3-4 7-9 8-10 13-15 14-16





JP4, JP5: COM1 / COM2 RS232 +5V/+12V Power Setting

JP4 / JP5	Setting	Function
	Pin 1-2 Short/Closed	+12V
	Pin 3-4 Short/Closed	Normal
	Pin 5-6 Short/Closed	+5V

JP8: Intel PCI LAN Enable/Disable



JP8	Function
	Enable LAN
	Disable LAN

JP9: DiskOnChip Address Select

JP9	Address
	D0000-D7FFF
	D8000-DFFFF (default)

JP10: Clear CMOS Contents

Use JP10, a 3-pin header, to clear the CMOS contents. *Note that the ATX-power connector should be disconnected from the CPU card before clearing CMOS.*

JP1	Setting	Function
	Pin 1-2 Short/Closed	Normal
	Pin 2-3 Short/Closed	Clear CMOS

Connectors on 3301610

The connectors on 3301610 allows you to connect external devices such as keyboard, floppy disk drives, hard disk drives, printers, etc. The following table lists the connectors on 3301610 and their respective functions.

Connector Locations on 3301610.....	13
IDE1: EIDE Connectors	14
FDD1: Floppy Drive Connector.....	14
CPU_FAN2: CPU Fan Power Connector.....	15
FAN1, FAN2: System Fan Power Connector.....	15
CN1: ATX 12V/+12V Power Connector	15
J1: Panel Inverter Power Connector	15
J2: System Function Connector.....	16
CN2, CN3, CN4, CN5: Serial ATA (SATA) Connectors	18
J3: External ATX Power Connector	18
J4: Parallel Port Connector	18
J5, J10: LVDS Connectors (1st channel, 2nd channel)	19
CN6: VGA CRT Connector.....	19
J6: Digital I/O Connector (4 in, 4 out).....	19
J7: Wake On LAN Connector.....	20
J8, J9: COM1 and COM2 Serial Ports Connector	20
J11: External Audio Connector	20
J12: CD-In Audio Connector.....	21
J14, J16: External PS/2 Keyboard and Mouse Connector	21
J15: IrDA Connector	21
J17: PS/2 Keyboard and Mouse Connector	21
J19: Intel PCI LAN RJ45 Connector	22
J20, J22: USB Connectors	22
J21: Marvell PCI Express GbE RJ45 Connector	22

Connector Locations on 3301610

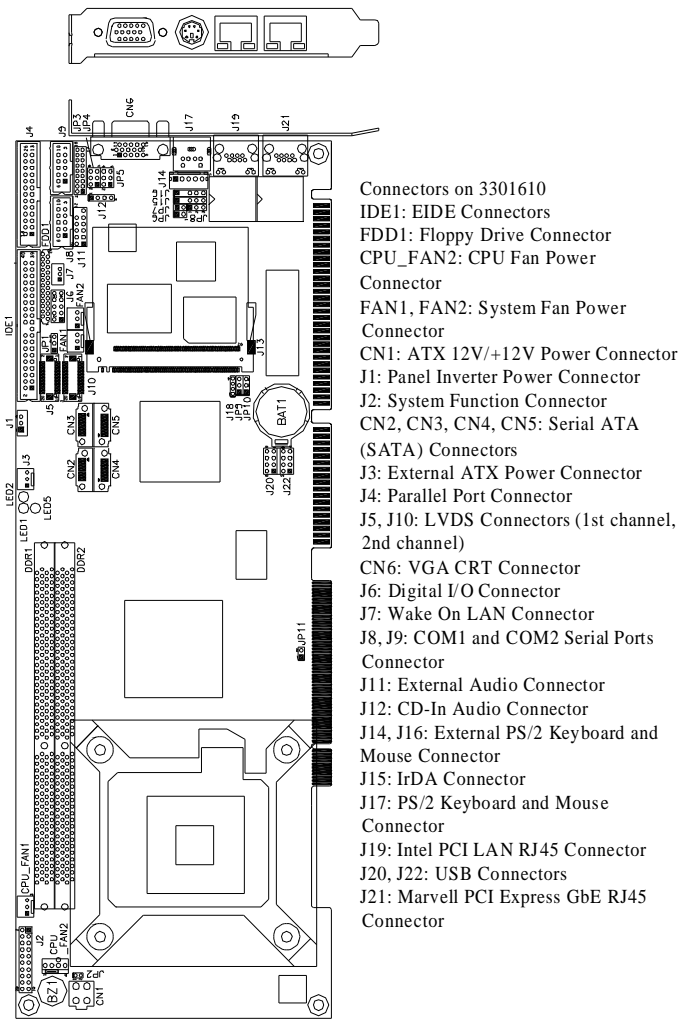

IDE1: EIDE Connectors

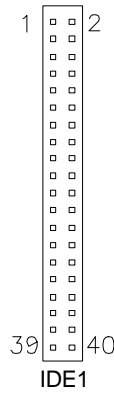

Signal Name	Pin #	Pin #	Signal Name
Reset IDE	1	2	Ground
Host data 7	3	4	Host data 8
Host data 6	5	6	Host data 9
Host data 5	7	8	Host data 10
Host data 4	9	10	Host data 11
Host data 3	11	12	Host data 12
Host data 2	13	14	Host data 13
Host data 1	15	16	Host data 14
Host data 0	17	18	Host data 15
Ground	19	20	Protect pin
DRQ0	21	22	Ground
Host IOW	23	24	Ground
Host IOR	25	26	Ground
IOCHRDY	27	28	Host ALE
DACK0	29	30	Ground
IRQ14	31	32	No connect
Address 1	33	34	No connect
Address 0	35	36	Address 2
Chip select 0	37	38	Chip select 1
Activity	39	40	Ground

FDD1: Floppy Drive Connector

FDD1 is a slim 26-pin connector and will support up to 2.88MB FDD.

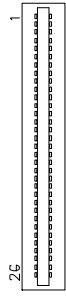

Signal Name	Pin #	Pin #	Signal Name
VCC	1	2	INDEX
VCC	3	4	DRV_SEL
VCC	5	6	DSK_CH
NC	7	8	NC
NC	9	10	MOTOR
DINST	11	12	DIR
NC	13	14	STEP
GND	15	16	WDATA
GND	17	18	WGATE
GND	19	20	TRACK
NC	21	22	WPROT
GND	23	24	RDATA
GND	25	26	SIDE

CPU_FAN2: CPU Fan Power Connector

This is a 3-pin header for the CPU fan. The fan must be a 12V fan.



Pin #	Signal Name
1	Ground
2	+12V
3	Rotation detection
4	Control

FAN1, FAN2: System Fan Power Connector

These are 3-pin headers for system fans. The fan must be a 12V fan.

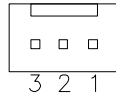

Pin #	Signal Name
1	Ground
2	+12V
3	Rotation detection

CN1: ATX 12V/+12V Power Connector

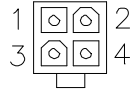

Pin #	Signal Name
1	Ground
2	Ground
3	+12V
4	+12V

J1: Panel Inverter Power Connector

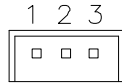

Pin #	Signal Name
1	+12V
2	ENABKL
3	Ground

Remarks: Maximum current is 1A.

J2: System Function Connector

J2 provides connectors for system indicators that provide light indication of the computer activities and switches to change the computer status. J1 is a 20-pin header that provides interfaces for the following functions.

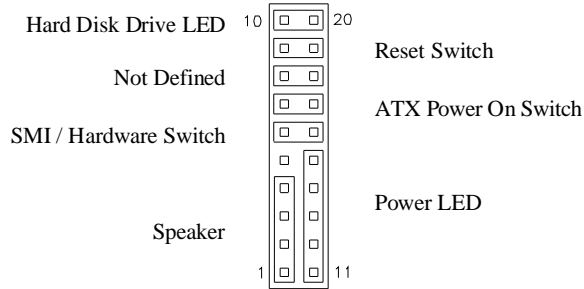

Speaker: Pins 1 - 4

This connector provides an interface to a speaker for audio tone generation. An 8-ohm speaker is recommended.

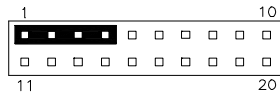

Pin #	Signal Name
1	Speaker out
2	No connect
3	Ground
4	+5V

Power LED: Pins 11 - 15

The power LED indicates the status of the main power switch.

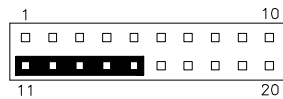

Pin #	Signal Name
11	Power LED
12	No connect
13	Ground
14	No connect
15	Ground

SMI/Hardware Switch: Pins 6 and 16

This connector supports the "Green Switch" on the control panel, which, when pressed, will force the system into the power-saving mode immediately.

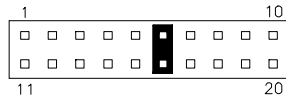

Pin #	Signal Name
6	SMI
16	Ground

ATX Power ON Switch: Pins 7 and 17

This 2-pin connector is an "ATX Power Supply On/Off Switch" on the system that connects to the power switch on the case. When pressed, the power switch will force the system to power on. When pressed again, it will force the system to power off.

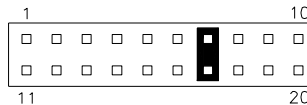

Reset Switch: Pins 9 and 19

The reset switch allows the user to reset the system without turning the main power switch off and then on again. Orientation is not required when making a connection to this header.

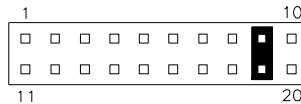

Hard Disk Drive LED Connector: Pins 10 and 20

This connector connects to the hard drive activity LED on control panel. This LED will flash when the HDD is being accessed.

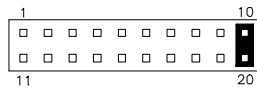

Pin #	Signal Name
10	HDD Active
20	5V

CN2, CN3, CN4, CN5: Serial ATA (SATA) Connectors

The SATA connectors support serial ATA 150. Each connector can only use one serial ATA hard disk. Port1 is CN3, Port 2 is CN5, Port 3 is CN2 and Port 4 is CN4.

J3: External ATX Power Connector

Pin #	Signal Name
1	Ground
2	PS-ON (soft on/off)
3	5VSB (Standby +5V)



J4: Parallel Port Connector

The following table describes the pin out assignments of this connector.

Signal Name	Pin #	Pin #	Signal Name
Line printer strobe	1	14	AutoFeed
PD0, parallel data 0	2	15	Error
PD1, parallel data 1	3	16	Initialize
PD2, parallel data 2	4	17	Select
PD3, parallel data 3	5	18	Ground
PD4, parallel data 4	6	19	Ground
PD5, parallel data 5	7	20	Ground
PD6, parallel data 6	8	21	Ground
PD7, parallel data 7	9	22	Ground
ACK, acknowledge	10	23	Ground
Busy	11	24	Ground
Paper empty	12	25	Ground
Select	13	N/A	N/A

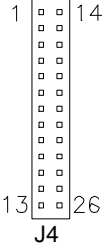

J5, J10: LVDS Connectors (1st channel, 2nd channel)

The LVDS connectors, DF13 20-pin mating connectors, are composed of the first channel (J5) and second channel (J10) to support 24-bit or 48-bit.

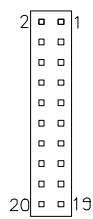

Signal Name	Pin #	Pin #	Signal Name
TX0-	2	1	TX0+
Ground	4	3	Ground
TX1-	6	5	TX1+
5V/3.3V	8	7	Ground
TX3-	10	9	TX3+
TX2-	12	11	TX2+
Ground	14	13	Ground
TXC-	16	15	TXC+
5V/3.3V	18	17	ENABKL
+12V	20	19	+12V

Remarks: Maximum current for +12V is 1A.

CN6: VGA CRT Connector

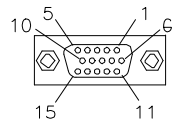

Signal Name	Pin #	Pin #	Signal Name
Red	1	2	Green
Blue	3	4	N.C.
GND	5	6	GND
GND	7	8	GND
N.C.	9	10	GND
N.C.	11	12	N.C.
HSYNC	13	14	VSYNC
NC	15		

J6: Digital I/O Connector (4 in, 4 out)

This connector supports TTL levels and is used to control external devices requiring on/off circuitry.

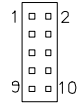

Signal Name	Pin #	Pin #	Signal Name
GND	1	2	+5V
OUT3	3	4	OUT1
Out2	5	6	Out0
In3	7	8	In1
In2	9	10	In0

J7: Wake On LAN Connector

J7 is a 3-pin header for the Wake On LAN function on the motherboard. The following table shows the pin out assignments of this connector. Wake On LAN will function properly only with an ATX power supply with 5VSB that has 1A.

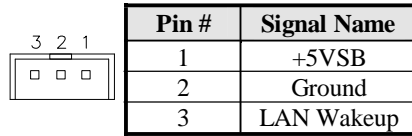

J8, J9: COM1 and COM2 Serial Ports Connector

J8 and J9 both 10-pin headers, are the onboard serial port connectors.

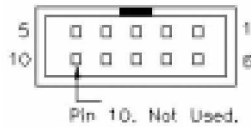

J8
Fixed as
RS-232

J9
Configurable
as RS-232/
RS-422/485
with jumpers
JP2/JP3/JP4

Pin #	Signal Name		
	RS-232	RS-422	RS-485
1	DCD	TX-	DATA-
2	RX	TX+	DATA+
3	TX	RX+	NC
4	DTR	RX-	NC
5	GND	GND	GND
6	DSR	RTS-	NC
7	RTS	RTS+	NC
8	CTS	CTS+	NC
9	RI	CTS-	NC
10	NC	NC	NC

J11: External Audio Connector

J11 is a 12-pin header that is used to connect to the optional audio cable that integrates jacks for Line In, Line Out and Mic.

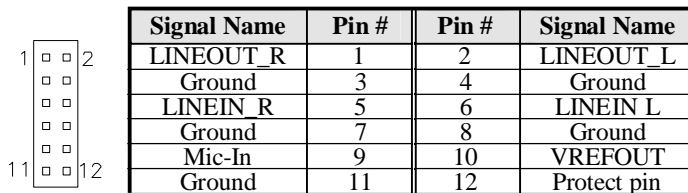

J12: CD-In Audio Connector

	Pin #	Signal Name
	1	CD Audio R
	2	Ground
	3	Ground
	4	CD Audio L

J14, J16: External PS/2 Keyboard and Mouse Connector

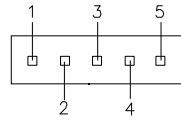
	Pin #	J14	J16
	1	KB clock	Mouse data
	2	KB data	N.C.
	3	N.C.	Ground
	4	Ground	Vcc
	5	Vcc	Mouse clock

J15: IrDA Connector

J15 is used for an optional IrDA connector for wireless communication.

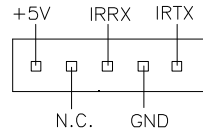
	Pin #	Signal Name
	1	+5V
	2	No connect
	3	Ir RX
	4	Ground
	5	Ir TX

J17: PS/2 Keyboard and Mouse Connector

J17 uses a Y-cable with dual D-connectors for a PS/2 keyboard and a PS/2 mouse.

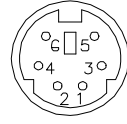
	Pin #	Signal Name
	1	Mouse data
	2	Keyboard data
	3	Ground
	4	Vcc
	5	Mouse Clock
	6	Keyboard Clock

J19: Intel PCI LAN RJ45 Connector

J19 is the RJ-45 connector based on the Intel PCI LAN controller. The figure below shows the pin out assignments of the connector and its corresponding input jack.

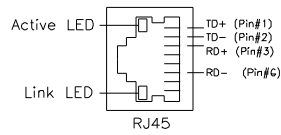

J20, J22: USB Connectors

The following table shows the pin outs of the USB pin headers connectors. Overall, the two pin headers support four USB ports.

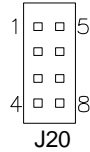

Signal Name	Pin	Pin	Signal Name
Vcc	1	5	Ground
USB0-	2	6	USB1+
USB0+	3	7	USB1-
Ground	4	8	Vcc

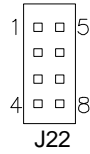

Signal Name	Pin	Pin	Signal Name
Vcc	1	5	Ground
USB2-	2	6	USB3+
USB2+	3	7	USB3-
Ground	4	8	Vcc

J21: Marvell PCI Express GbE RJ45 Connector

J21 is the Gigabit LAN RJ45 connector based on the Marvell PCI Express GbE controller.

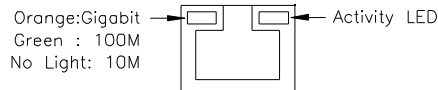

Watchdog Timer Configuration

The WDT is used to generate a variety of output signals after a user programmable count. The WDT is suitable for use in the prevention of system lock-up, such as when software becomes trapped in a deadlock. Under these sort of circumstances, the timer will count to zero and the selected outputs will be driven. Under normal circumstance, the user will restart the WDT at regular intervals before the timer counts to zero.

SAMPLE CODE:

This code and information is provided "as is" without warranty of any kind, either expressed or implied, including but not limited to the implied warranties of merchantability and/or fitness for a particular purpose.

```

;[]=====
; Name  : Enable_And_Set_Watchdog
; IN    : AL - 1sec ~ 255sec
; OUT   : None
;[]=====
Enable_And_Set_Watchdog Proc Near
    push    ax                ;save time interval
    call   Unlock_Chip

    mov    cl, 2Bh
    call  Read_Reg
    and   al, NOT 10h
    call  Write_Reg          ;set GP24 as WDTO

    mov    cl, 07h
    mov    al, 08h
    call  Write_Reg          ;switch to LD8

```

```

        mov cl, 0F5h
        call Read_Reg
        and al, NOT 08h
        call Write_Reg      ;set count mode as second

        pop ax
        mov cl, 0F6h
        call Write_Reg      ;set watchdog timer

        mov al, 01h
        mov cl, 30h
        call Write_Reg      ;watchdog enabled

        call Lock_Chip
        ret
Enable_And_Set_Watchdog Endp
;[]=====
; Name : Disable_Watchdog
; IN   : None
; OUT  : None
;[]=====
Disable_Watchdog Proc Near
        call Unlock_Chip

        mov cl, 07h
        mov al, 08h
        call Write_Reg      ;switch to LD8

        xor al, al
        mov cl, 0F6h
        call Write_Reg      ;clear watchdog timer

        xor al, al
        mov cl, 30h
        call Write_Reg      ;watchdog disabled

        call Lock_Chip
        ret
Disable_Watchdog Endp
;[]=====

```

```
; Name : Unlock_Chip
; IN : None
; OUT : None
;[]=====
Unlock_Chip Proc Near
    Mov dx, 4Eh
    mov al, 87h
    out dx, al
    out dx, al
    ret
Unlock_Chip Endp
;[]=====
; Name : Lock_Chip
; IN : None
; OUT : None
;[]=====
Unlock_Chip Proc Near
    mov dx, 4Eh
    mov al, 0AAh
    out dx, al
    ret
Unlock_Chip Endp
;[]=====
; Name : Write_Reg
; IN : CL - register index
; AL - Value to write
; OUT : None
;[]=====
Write_Reg Proc Near
    push ax
    mov dx, 4Eh
    mov al, cl
    out dx, al
    pop ax
    inc dx
    out dx, al
    ret
Write_Reg Endp
;[]=====
```

```

; Name : Read_Reg
; IN : CL - register index
; OUT : AL - Value to read
;[]=====
==
Read_Reg Proc Near
    Mov al, cl
    mov dx, 4Eh
    out dx, al
    inc dx
    in al, dx
    ret
Read_Reg Endp
;[]=====

```

Digital I/O Sample Code

```
Filename: W627hf.h
//=====
//
// THIS CODE AND INFORMATION IS PROVIDED "AS IS" WITHOUT WARRANTY OF ANY
// KIND, EITHER EXPRESSED OR IMPLIED, INCLUDING BUT NOT LIMITED TO THE
// IMPLIED WARRANTIES OF MERCHANTABILITY AND/OR FITNESS FOR A PARTICULAR
// PURPOSE.
//
//=====
#ifndef __W627HF_H
#define __W627HF_H          1
//=====
#define W627_IOWBASE      0x4E
//=====
#define W627HF_INDEX_PORT (W627_IOWBASE+0)
#define W627HF_DATA_PORT  (W627_IOWBASE+1)
//=====
#define W627HF_REG_LD     0x07
//=====
#define W627HF_UNLOCK    0x87
#define W627HF_LOCK      0xAA
//=====
void Set_W627HF_LD(unsigned char);
void Set_W627HF_Reg(unsigned char, unsigned char);
unsigned char Get_W627HF_Reg(unsigned char);
//=====
#endif  //__W627HF_H
```

```

Filename: W627hf.cpp
//=====
//
// THIS CODE AND INFORMATION IS PROVIDED "AS IS" WITHOUT WARRANTY OF ANY
// KIND, EITHER EXPRESSED OR IMPLIED, INCLUDING BUT NOT LIMITED TO THE
// IMPLIED WARRANTIES OF MERCHANTABILITY AND/OR FITNESS FOR A PARTICULAR
// PURPOSE.
//
//=====
#include "W627HF.H"
#include <dos.h>
//=====
void Unlock_W627HF (void);
void Lock_W627HF (void);
//=====
void Unlock_W627HF (void)
{
    outportb(W627HF_INDEX_PORT, W627HF_UNLOCK);
    outportb(W627HF_INDEX_PORT, W627HF_UNLOCK);
}
//=====
void Lock_W627HF (void)
{
    outportb(W627HF_INDEX_PORT, W627HF_LOCK);
}
//=====
void Set_W627HF_LD( unsigned char LD)
{
    Unlock_W627HF();
    outportb(W627HF_INDEX_PORT, W627HF_REG_LD);
    outportb(W627HF_DATA_PORT, LD);
    Lock_W627HF();
}
//=====
void Set_W627HF_Reg( unsigned char REG, unsigned char DATA)
{
    Unlock_W627HF();
    outportb(W627HF_INDEX_PORT, REG);
    outportb(W627HF_DATA_PORT, DATA);
    Lock_W627HF();
}
//=====
unsigned char Get_W627HF_Reg( unsigned char REG)
{
    unsigned char Result;
    Unlock_W627HF();
    outportb(W627HF_INDEX_PORT, REG);
    Result = inportb(W627HF_DATA_PORT);
    Lock_W627HF();
    return Result;
}
//=====

```



```

File of the Main.cpp
=====
//
// THIS CODE AND INFORMATION IS PROVIDED "AS IS" WITHOUT WARRANTY OF ANY
// KIND, EITHER EXPRESSED OR IMPLIED, INCLUDING BUT NOT LIMITED TO THE
// IMPLIED WARRANTIES OF MERCHANTABILITY AND/OR FITNESS FOR A PARTICULAR
// PURPOSE.
//
=====
#include <dos.h>
#include <conio.h>
#include <stdio.h>
#include <stdlib.h>
#include "W627HF.H"
=====
void ClrKbBuf(void);
int main (int argc, char *argv[]);
=====
int main (int argc, char *argv[])
{
    unsigned char ucDO = 0;           //data for digital output
    unsigned char ucDI;              //data for digital input
    unsigned char ucBuf;

    Set_W627HF_LD( 0x07);            //switch to logic device 7

    Set_W627HF_Reg(0xF1, 0x00);      //clear
    ucDI = Get_W627HF_Reg(0xF1) & 0x0F;

    ClrKbBuf();
    while(1)
    {
        ucDO++;
        Set_W627HF_Reg(0xF1, ((ucDO & 0x0F) << 4));
        ucBuf = Get_W627HF_Reg(0xF1) & 0x0F;
        if (ucBuf != ucDI)
        {
            ucDI = ucBuf;
            printf("Digital I/O Input Changed. Current Data is 0x%X\n",ucDI);
        }

        if (kbhit())
        {
            getch();
            break;
        }
        delay(500);
    }
    return 0;
}
=====
void ClrKbBuf(void)
{
    while(kbhit())
    {   getch();   }
}
=====

```

BIOS Setup

This chapter describes the different settings available in the Award BIOS that comes with the motherboard. The topics covered in this chapter are as follows:

BIOS Introduction	31
BIOS Setup.....	31
Standard CMOS Features	33
Advanced BIOS Features	36
Advanced Chipset Features	40
Integrated Peripherals	42
Power Management Setup	47
PNP/PCI Configurations	50
PC Health Status	52
Frequency/Voltage Control.....	53
Load Fail-Safe Defaults.....	54
Load Optimized Defaults	54
Set Supervisor/User Password.....	54
Save & Exit Setup	54
Exit Without Saving.....	54

BIOS Introduction

The Award BIOS (Basic Input/Output System) installed in your computer system's ROM supports Intel® Pentium® 4 processors. The BIOS provides critical low-level support for a standard device such as disk drives, serial ports and parallel ports. It also adds virus and password protection as well as special support for detailed fine-tuning of the chipset controlling the entire system.

BIOS Setup

The Award BIOS provides a Setup utility program for specifying the system configurations and settings. The BIOS ROM of the system stores the Setup utility. When you turn on the computer, the Award BIOS is immediately activated. Pressing the key immediately allows you to enter the Setup utility. If you are a little bit late pressing the key, POST (Power On Self Test) will continue with its test routines, thus preventing you from invoking the Setup. If you still wish to enter Setup, restart the system by pressing the "Reset" button or simultaneously pressing the <Ctrl>, <Alt> and <Delete> keys. You can also restart by turning the system Off and back On again. The following message will appear on the screen:

Press to Enter Setup

In general, you press the arrow keys to highlight items, <Enter> to select, the <PgUp> and <PgDn> keys to change entries, <F1> for help and <Esc> to quit.

When you enter the Setup utility, the Main Menu screen will appear on the screen. The Main Menu allows you to select from various setup functions and exit choices.

Phoenix - AwardBIOS CMOS Setup Utility

Standard CMOS Features	Frequency/Voltage Control
Advanced BIOS Features	Load Fail-Safe Defaults
Advanced Chipset Features	Load Optimized Defaults
Integrated Peripherals	Set Supervisor Password
Power Management Setup	Set User Password
PnP/PCI Configurations	Save & Exit Setup
PC Health Status	Exit Without Saving
ESC : Quit	Ç È Æ Å : Select Item
F10 : Save & Exit Setup	
Time, Date, Hard Disk Type...	

The section below the setup items of the Main Menu displays the control keys for this menu. At the bottom of the Main Menu just below the control keys section, there is another section, which displays information on the currently highlighted item in the list.

Note: *If the system cannot boot after making and saving system changes with Setup, the Award BIOS supports an override to the CMOS settings that resets your system to its default.*

Warning: *It is strongly recommended that you avoid making any changes to the chipset defaults. These defaults have been carefully chosen by both Award and your system manufacturer to provide the absolute maximum performance and reliability. Changing the defaults could cause the system to become unstable and crash in some cases.*

Standard CMOS Features

“Standard CMOS Features” choice allows you to record some basic hardware configurations in your computer system and set the system clock and error handling. If the motherboard is already installed in a working system, you will not need to select this option. You will need to run the Standard CMOS option, however, if you change your system hardware configurations, the onboard battery fails, or the configuration stored in the CMOS memory was lost or damaged.

Phoenix - AwardBIOS CMOS Setup Utility
Standard CMOS Features

Date (mm:dd:yy)	Mon, Jul 11, 2005	Item Help
Time (hh:mm:ss)	16 : 46 : 00	Menu Level
IDE Channel 0 Master	None	Change the day, month, Year and century
IDE Channel 0 Slave	None	
IDE Channel 1 Master	None	
IDE Channel 1 Slave	None	
Drive A	None	
Drive B	None	
Video	EGA/VGA	
Halt On	All , But Keyboard	
Base Memory	640K	
Extended Memory	252928K	
Total Memory	253952K	

At the bottom of the menu are the control keys for use on this menu. If you need any help in each item field, you can press the <F1> key. It will display the relevant information to help you. The memory display at the lower right-hand side of the menu is read-only. It will adjust automatically according to the memory changed. The following describes each item of this menu.

Date

The date format is:

- Day :** Sun to Sat
- Month :** 1 to 12
- Date :** 1 to 31
- Year :** 1999 to 2099

To set the date, highlight the “Date” field and use the PageUp/ PageDown or +/- keys to set the current time.

Time

The time format is: **Hour** : 00 to 23
Minute : 00 to 59
Second : 00 to 59

To set the time, highlight the "Time" field and use the <PgUp>/ <PgDn> or +/- keys to set the current time.

IDE Primary HDDs / IDE Secondary HDDs

The onboard PCI IDE connectors provide Primary and Secondary channels for connecting up to four IDE hard disks or other IDE devices. Each channel can support up to two hard disks; the first is the "Master" and the second is the "Slave".

Press <Enter> to configure the hard disk. The selections include Auto, Manual, and None. Select 'Manual' to define the drive information manually. You will be asked to enter the following items.

Capacity : Capacity/size of the hard disk drive
Cylinder : Number of cylinders
Head : Number of read/write heads
Precomp : Write precompensation
Landing Zone : Landing zone
Sector : Number of sectors

The Access Mode selections are as follows:

CHS (HD < 528MB)
LBA (HD > 528MB and supports Logical Block Addressing)
Large (for MS-DOS only)
Auto

Remarks: The main board supports two serial ATA ports and are represented in this setting as IDE Channel 2 / 3 Master.

Drive A / Drive B

These fields identify the types of floppy disk drive A or drive B that has been installed in the computer. The available specifications are:

360KB	1.2MB	720KB	1.44MB	2.88MB
5.25 in.	5.25 in.	3.5 in.	3.5 in.	3.5 in.

Video

This field selects the type of video display card installed in your system.

You can choose the following video display cards:

EGA/VGA	For EGA, VGA, SEGA, SVGA or PGA monitor adapters. (default)
CGA 40	Power up in 40 column mode.
CGA 80	Power up in 80 column mode.
MONO	For Hercules or MDA adapters.

Halt On

This field determines whether or not the system will halt if an error is detected during power up.

No errors	The system boot will not be halted for any error that may be detected.
All errors	Whenever the BIOS detects a non-fatal error, the system will stop and you will be prompted.
All, But Keyboard	The system boot will not be halted for a keyboard error; it will stop for all other errors
All, But Diskette	The system boot will not be halted for a disk error; it will stop for all other errors.
All, But Disk/Key	The system boot will not be halted for a keyboard or disk error; it will stop for all others.

Advanced BIOS Features

This section allows you to configure and improve your system and allows you to set up some system features according to your preference.

Phoenix - AwardBIOS CMOS Setup Utility
Advanced BIOS Features

CPU Feature	Press Enter	ITEM HELP
Hard Disk Boot Priority	Press Enter	
Virus Warning	Disabled	Menu Level
CPU L1 and L2 Cache	Enabled	
Hyper-threading Technology	Enabled	
Quick Power On Self Test	Enabled	
First Boot Device	Floppy	
Second Boot Device	Hard Disk	
Third Boot Device	CD-ROM	
Boot Other Device	Enabled	
Swap Floppy Drive	Disabled	
Boot Up Floppy Seek	Disabled	
Boot Up Numlock Status	On	
Gate A20 Option	Fast	
Typematic Rate Setting	Disabled	
Typematic Rate (chars/Sec)	6	
Typematic Delay (Msec)	250	
Security Option	Setup	
APIC Mode	Enabled	
MPS Version Control for OS	1.4	
Report No FDD For WIN 95	Yes	
Small Logo (EPA) Show	Disabled	

CPU Feature

Press Enter to configure the settings relevant to CPU Feature.

Hard Disk Boot Priority

This item allows you to set the priority for hard disk boot. When you press enter, the selections shows the current hard disks used in your system as well as the “Bootable Add-in Card” that is relevant to other boot sources media such as SCSI cards and LAN cards.

Virus Warning

If this option is enabled, an alarm message will be displayed when trying to write on the boot sector or on the partition table on the disk, which is typical of the virus.

CPU L1 and L2 Cache

Cache memory is additional memory that is much faster than conventional DRAM (system memory). CPUs from 486-type on up contain internal cache memory, and most, but not all, modern PCs have additional (external) cache memory. When the CPU requests data, the system transfers the requested data from the main DRAM into cache memory, for even faster access by the CPU. These items allow you to enable (speed up memory access) or disable the cache function. By default, these items are Enabled.

Hyper-Threading Technology

This feature is enabled when your processor supports Hyper-Threading Technology. Otherwise, this field will be hidden.

Quick Power On Self Test

When enabled, this field speeds up the Power On Self Test (POST) after the system is turned on. If it is set to *Enabled*, BIOS will skip some items.

First/Second/Third Boot Device

These fields determine the drive that the system searches first for an operating system. The options available include *Floppy,LS120,Hard Disk,CDROM,ZIP100,USB-FDD,USB-ZIP,USB-CDROM,LAN* and *Disable*.

Boot Other Device

These fields allow the system to search for an operating system from other devices other than the ones selected in the First/Second/Third Boot Device.

Swap Floppy Drive

This item allows you to determine whether or not to enable Swap Floppy Drive. When enabled, the BIOS swaps floppy drive assignments so that Drive A becomes Drive B, and Drive B becomes Drive A. By default, this field is set to *Disabled*.

Boot Up Floppy Seek

This feature controls whether the BIOS checks for a floppy drive while booting up. If it cannot detect one (either due to improper configuration or its absence), it will flash an error message.

Boot Up NumLock Status

This allows you to activate the NumLock function after you power up the system.

Gate A20 Option

This field allows you to select how Gate A20 is worked. Gate A20 is a device used to address memory above 1 MB.

Typematic Rate Setting

When disabled, continually holding down a key on your keyboard will generate only one instance. When enabled, you can set the two typematic controls listed next. By default, this field is set to *Disabled*.

Typematic Rate (Chars/Sec)

When the typematic rate is enabled, the system registers repeated keystrokes speeds. Settings are from 6 to 30 characters per second.

Typematic Delay (Msec)

When the typematic rate is enabled, this item allows you to set the time interval for displaying the first and second characters. By default, this item is set to *250msec*.

Security Option

This field allows you to limit access to the System and Setup. The default value is *Setup*. When you select *System*, the system prompts for the User Password every time you boot up. When you select *Setup*, the system always boots up and prompts for the Supervisor Password only when the Setup utility is called up.

APIC Mode

APIC stands for Advanced Programmable Interrupt Controller. The default setting is *Enabled*.

MPS Version Control for OS

This option is specifies the MPS (Multiprocessor Specification) version for your operating system. MPS version 1.4 added extended configuration tables to improve support for multiple PCI bus configurations and improve future expandability. The default setting is *1.4*.

OS Select for DRAM > 64MB

This option allows the system to access greater than 64MB of DRAM memory when used with OS/2 that depends on certain BIOS calls to access memory. The default setting is *Non-OS/2*.

Report No FDD For WIN 95

If you are using Windows 95/98 without a floppy disk drive, select Enabled to release IRQ6. This is required to pass Windows 95/98's SCT test. You should also disable the Onboard FDC Controller in the Integrated Peripherals screen when there's no floppy drive in the system. If you set this feature to Disabled, the BIOS will not report the missing floppy drive to Win95/98.

Small Logo (EPA) Show

The EPA logo appears at the right side of the monitor screen when the system is boot up. The default setting is *Disabled*.

Advanced Chipset Features

This Setup menu controls the configuration of the chipset.

Phoenix - AwardBIOS CMOS Setup Utility
Advanced Chipset Features

		ITEM HELP
DRAM Timing Selectable	By SPD	Menu Level
CAS Latency Time	4	
DRAM RAS# to CAS# Delay	4	
DRAM RAS# Precharge	4	
Precharge dealy (tRAS)	12	
System Memory Frequency	Auto	
SLP_S4# Assertion Width	1 to 2 Sec.	
System BIOS Cacheable	Enabled	
Video BIOS Cacheable	Enabled	
Memory Hole at 15M-16M	Disabled	
PCI Express Root Port Func	Press Enter	
** VGA Setting **		
On-Chip Video Memory Size	Press Enter	
On-Chip Frame Buffer Size	8MB	
FIXED Memory Size	64MB	
DVMT Memory Size	64MB	
SDVO Device Setting	LVDS	
SDVO LVDS Protocol	1 Ch SPGW 18bit	
SDVO Panel Number	1024 x 768	
Boot Display	CRT	
Panel Scaling	Auto	

DRAM Timing Selectable

This option refers to the method by which the DRAM timing is selected. The default is *By SPD*.

CAS Latency Time

You can configure CAS latency time in HCLKs as 2 or 2.5 or 3. The system board designer should set the values in this field, depending on the DRAM installed. Do not change the values in this field unless you change specifications of the installed DRAM or the installed CPU.

DRAM RAS# to CAS# Delay

This option allows you to insert a delay between the RAS (Row Address Strobe) and CAS (Column Address Strobe) signals. This delay occurs when the SDRAM is written to, read from or refreshed. Reducing the delay improves the performance of the SDRAM.

DRAM RAS# Precharge

This option sets the number of cycles required for the RAS to accumulate its charge before the SDRAM refreshes. The default setting for the Active to Precharge Delay is **4**.

Precharge Delay (tRAS)

The default setting for the Precharge Delay is *12*.

System Memory Frequency

This field sets the frequency of the DRAM memory installed. The default setting is *Auto*. The other settings are *DDR333*, *DDR400*, and *DDR533*.

SLP_S4# Assertion Width

Pushing the power button for 1 to 2 seconds will power off the system. This will prevent the system from powering off in case you accidentally hit or pushed the power button.

System BIOS Cacheable

The setting of *Enabled* allows caching of the system BIOS ROM at F000h-FFFFh, resulting in better system performance. However, if any program writes to this memory area, a system error may result.

Video BIOS Cacheable

The Setting *Enabled* allows caching of the video BIOS ROM at C0000h-F7FFFh, resulting in better video performance. However, if any program writes to this memory area, a system error may result.

Memory Hole At 15M-16M

In order to improve performance, certain space in memory can be reserved for ISA cards. This memory must be mapped into the memory space below 16 MB. The choices are *Enabled* and *Disabled*.

PCI Express Root Port Func

Press <Enter> to set the items of PCI Express root port function.

On-Chip Video Memory Size

Select On-Chip Frame Buffer Size, FIXED Memory Size and DVMT Memory Size, Total Graphics Memory can be set 64MB, 128MB or 224MB.

On-Chip Frame Buffer Size

The On-Chip Frame Buffer Size can be set us 1MB, 8MB. This memory is shared with the system memory.

DVMT/FIXED Memory Size

Select On-Chip Frame Buffer Size, FIXED Memory Size and DVMT Memory Size, Total Graphics Memory can be set 64MB or 128MB. Specify the size of DVMT memory to allocate for video memory, Specify the size of system memory to allocate for video memory.

SDVO Device Setting

These fields allow you to select the LVDS Panel. The options available include *None* and *LVDS*.

SDVO LVDS Protocol

The default setting is *1 Ch SPGW 18bit*. The options available include *1 Ch SPGW 18bit*, *2 Ch SPGW 18bit*, *1 Ch OpenLDI 18bit*, *2 Ch OpenLDI 18bit*, *1 Ch SPGW 24bit*, *2 Ch SPGW 24bit*, *1 Ch OpenLDI 24bit* and *2 Ch OpenLDI 24bit*.

SDVO Panel Number

The default setting is *1024x768*. The options available include *1024x768*, *1280x1024*, *1366x768*, *1400x1050* and *1600x1200*.

Boot Display

The default setting is *CRT*. The options available include *CRT+LVDS* and *LVDS*.

Panel Scaling

The default setting is *Auto*. The options available include *On* and *Off*.

Integrated Peripherals

This section sets configurations for your hard disk and other integrated peripherals. The first screen shows three main items for user to select. Once an item selected, a submenu appears. Details follow.

Phoenix - AwardBIOS CMOS Setup Utility
Integrated Peripherals

On-Chip IDE Device	Press Enter	ITEM HELP
Onboard Device	Press Enter	Menu Level
Super IO Device	Press Enter	
Onboard GigaLan BootROM	Disabled	

Phoenix - AwardBIOS CMOS Setup Utility
OnChip IDE Device

IDE Block Mode	Enabled	ITEM HELP
DE DMA transfer access	Enabled	
On-Chip Primary PCI IDE	Enabled	
IDE Primary Master PIO	Auto	If your IDE hard drive supports block mode select Enabled for automatic detection of the optimal number of block read/writes per sector the drive can support
IDE Primary Slave PIO	Auto	
IDE Primary Master UDMA	Auto	
IDE Primary Slave UDMA	Auto	
On-Chip Secondary PCI IDE	Enabled	
IDE Secondary Master PIO	Auto IDE	
Secondary Slave PIO	Auto IDE	
Secondary Master UDMA	Auto IDE	
Secondary Slave UDMA	Auto	
*** On-Chip Serial ATA Setting ***		
On-Chip Serial ATA	Auto	
PATA IDE Mode	Primary	
SATA Port	P1,P3 is Secondary	

Phoenix - AwardBIOS CMOS Setup Utility
Onboard Device

USB Controller	Enabled	ITEM HELP
USB 2.0 Controller	Enabled	Menu Level
USB Keyboard Support	Disabled	
USB Mouse Support	Disabled	
Azalia/AC97 Audio Select	Auto	
Onboard PCI-E Giga LAN	Enabled	

Phoenix - AwardBIOS CMOS Setup Utility
SuperIO Device

		ITEM HELP
POWER ON Function	BUTTON ONLY	
KB Power ON Password	Enter	Menu Level
Hot Key Power ON	Ctrl-F1	
Onboard FDC Controller	Enabled	
Onboard Serial Port 1	3F8/IRQ4	
Onboard Serial Port 2	2F8/IRQ3	
UART Mode Select	Normal Hi,	
RxD , TxD Active	Lo	
IR Transmission Delay	Enabled	
UR2 Duplex Mode	Half	
Use IR Pins	IR-Rx2Tx2	
Onboard Parallel Port	378/IRQ7	
Parallel Port Mode	SPP	
EPP Mode Select	EPP1.7	
ECP Mode Use DMA	3	
Power After PWR-Fail	Off	

IDE HDD Block Mode

This field allows your hard disk controller to use the fast block mode to transfer data to and from your hard disk drive.

IDE DMA Transfer Access

This field, by default, is Enabled.

OnChip Primary/Secondary PCI IDE

The integrated peripheral controller contains an IDE interface with support for two IDE channels. Select *Enabled* to activate each channel separately.

IDE Primary/Secondary Master/Slave PIO

These fields allow your system hard disk controller to work faster. Rather than have the BIOS issue a series of commands that transfer to or from the disk drive, PIO (Programmed Input/Output) allows the BIOS to communicate with the controller and CPU directly.

The system supports five modes, numbered from 0 (default) to 4, which primarily differ in timing. When Auto is selected, the BIOS will select the best available mode.

IDE Primary/Secondary Master/Slave UDMA

These fields allow your system to improve disk I/O throughput to 33Mb/sec with the Ultra DMA/33 feature. The options are *Auto* and *Disabled*.

On-Chip Serial ATA

The default setting of *Auto* allows the Serial ATA drive to be enabled, when the system detects one.

USB Controller

The options for this field are *Enabled* and *Disabled*. By default, this field is set to *Enabled*.

USB 2.0 Controller

The options for this field are *Enabled* and *Disabled*. By default, this field is set to *Enabled*. In order to use USB 2.0, necessary OS drivers must be installed first.

USB Keyboard Support

The options for this field are *Enabled* and *Disabled*. By default, this field is set to *Disabled*.

USB Mouse Support

The options for this field are *Enabled* and *Disabled*. By default, this field is set to *Disabled*.

Azalia/AC97 Audio Select

The default setting of the Azalia/AC97 Audio Select is *Auto*.

Onboard PCI-E Giga LAN

The default setting of the PCI-E Giga LAN controller is *Enabled*.

Power ON Function

This field is related to how the system is powered on – such as with the use of conventional power button, keyboard or hot keys. The default is *BUTTON ONLY*.

KB Power ON Password

This field allows users to set the password when keyboard power on is the mode of the Power ON function.

Hot Key Power ON

This field sets certain keys, also known as hot keys, on the keyboard that can be used as a ‘switch’ to power on the system.

Onboard FDC Controller

Select *Enabled* if your system has a floppy disk controller (FDC) installed on the motherboard and you wish to use it. If you install an add-in FDC or the system has no floppy drive, select *Disabled* in this field. This option allows you to select the onboard FDD port.

Onboard Serial/Parallel Port

These fields allow you to select the onboard serial and parallel ports and their addresses. The default values for these ports are:

Serial Port 1	3F8/IRQ4
Serial Port 2	2F8/IRQ3
Parallel Port	378/IRQ7

UART Mode Select

This field determines the UART 2 mode in your computer. The default value is *Normal*. Other options include *IrDA* and *ASKIR*.

Parallel Port Mode

This field allows you to determine parallel port mode function.

SPP	Standard Printer Port
EPP	Enhanced Parallel Port
ECP	Extended Capabilities Port
ECP+EPP	Combination of ECP and EPP capabilities
Normal	Normal function

PWRON After PWR-Fail

This field sets the system power status whether *on* or *off* when power returns to the system from a power failure situation.

Power Management Setup

The Power Management Setup allows you to save energy of your system effectively.

Phoenix - AwardBIOS CMOS Setup Utility		ITEM HELP
Power Management Setup		Menu Level
PCI Express PM Function	Press Enter	
ACPI Function	Enabled	
Power Management	User Define	
Video Off Method	V/H SYNC+Blank	
Video Off In Suspend	Yes	
Suspend Type	Stop Grant	
Modem Use IRQ	3	
Suspend Mode	Disabled	
HDD Power Down	Disabled	
Soft-Off by PWR-BTTN	Instant-Off	
CPU THRM-Throttling	50%	
Wake-Up by PCI Card	Disabled	
Power On by Ring Wake	Disabled	
Up On LAN	Disabled	
Resume by Alarm	Disabled	
Date (of Month) Alarm	0	
Time (hh:mm:ss) Alarm	0 : 0 : 0	
** Reload Global Timer Events **		
Primary IDE 0	Enabled	
Primary IDE 1	Enabled	
Secondary IDE 0	Enabled	
Secondary IDE 1	Enabled	
FDD, COM, LPT Port	Enabled	
PCI PIRQ[A-D] #	Enabled	

ACPI Function

Enable this function to support ACPI (Advance Configuration and Power Interface).

Power Management

This field allows you to select the type of power saving management modes. There are four selections for Power Management.

- Min. Power Saving Minimum power management
- Max. Power Saving Maximum power management.
- User Define Each of the ranges is from 1 min. to 1hr. Except for HDD Power Down which ranges from 1 min. to 15 min.

Video Off Method

This field defines the Video Off features. There are three options.

V/H SYNC + Blank	Default setting, blank the screen and turn off vertical and horizontal scanning.
DPMS	Allows BIOS to control the video display.
Blank Screen	Writes blanks to the video buffer.

Video Off In Suspend

When enabled, the video is off in suspend mode. The default setting is *Yes*.

Suspend Type

The default setting for the Suspend Type field is *Stop Grant*.

Modem Use IRQ

This field sets the IRQ used by the Modem. By default, the setting is **3**.

Suspend Mode

When enabled, and after the set time of system inactivity, all devices except the CPU will be shut off.

HDD Power Down

When enabled, and after the set time of system inactivity, the hard disk drive will be powered down while all other devices remain active.

Soft-Off by PWRBTN

This field defines the power-off mode when using an ATX power supply. The *Instant Off* mode allows powering off immediately upon pressing the power button. In the *Delay 4 Sec* mode, the system powers off when the power button is pressed for more than four seconds or enters the suspend mode when pressed for less than 4 seconds.

CPU THRM-Throttling

When the system enters Doze mode, the CPU clock runs only part of the time. You may select the percent of time that the clock runs.

Wake-Up by PCI Card

Enable this field to allow wake up function through a PCI card.

Power On by Ring

This field enables or disables the power on of the system through the modem connected to the serial port or LAN.

Wake Up On LAN

Enable this field to allow wake up function through Onboard Giga Ethernet.

Resume by Alarm

This field enables or disables the resumption of the system operation. When enabled, the user is allowed to set the *Date* and *Time*.

Reload Global Timer Events

The HDD, FDD, COM, LPT Ports, and PCI PIRQ are I/O events that can prevent the system from entering a power saving mode or can awaken the system from such a mode. When an I/O device wants to gain the attention of the operating system, it signals this by causing an IRQ to occur. When the operating system is ready to respond to the request, it interrupts itself and performs the service.

PNP/PCI Configurations

This option configures the PCI bus system. All PCI bus systems on the system use INT#, thus all installed PCI cards must be set to this value.

Phoenix - AwardBIOS CMOS Setup Utility
PnP/PCI Configurations

PNP OS Installed	No	ITEM HELP
Init Display First	PCI Slot	Menu Level
Reset Configuration Data	Disabled	
Resources Controlled By	Auto (ESCD)	Default is Disabled.
IRQ Resources	Press Enter	Select Enabled to reset
DMA Resources	Press Enter	Extended System
PCI/VGA Palette Snoop	Disabled	Configuration Data
INT Pin 1 Assignment	Auto	(ESCD) when you exit
INT Pin 2 Assignment	Auto	Setup if you have
INT Pin 3 Assignment	Auto	installed a new add-on
INT Pin 4 Assignment	Auto	and the system
INT Pin 5 Assignment	Auto	reconfiguration has
INT Pin 6 Assignment	Auto	caused such a serious
INT Pin 7 Assignment	Auto	conflict that the OS
INT Pin 8 Assignment	Auto	cannot boot
** PCI Express relative items **		
Maximum Payload Size	4096	

PNP OS Install

Enable the PNP OS Install option if it is supported by the operating system installed. The default value is *No*.

Init Display First

This field allows the system to initialize first the VGA on chip or the display card on the PCI Slot.

Reset Configuration Data

This field allows you to determine whether to reset the configuration data or not. The default value is *Disabled*.

Resources Controlled by

This PnP BIOS can configure all of the boot and compatible devices automatically with the use of a use a PnP operating system such as Windows 95.

PCI/VGA Palette Snoop

Some non-standard VGA display cards may not show colors properly. This field allows you to set whether or not MPEG ISA/VESA VGA cards can work with PCI/VGA. When this field is enabled, a PCI/VGA can work with an MPEG ISA/VESA VGA card. When this field is disabled, a PCI/VGA cannot work with an MPEG ISA/VESA card.

Maximum Payload Size

This option is used to set maximum TLP payload size for PCI Express devices. The unit is byte. The available setting values are: 128, 256, 512, 1024, 2048 and 4096.

PC Health Status

This section shows the parameters in determining the PC Health Status. These parameters include temperatures, fan speeds and voltages.

Phoenix - AwardBIOS CMOS Setup Utility
PC Health Status

CPU Warning Temperature	Disabled	ITEM HELP
System Temp	43°C/109°F	
CPU Temp	43°C/109°F	
CPU FAN Speed(CPU_FAN2)	4236 RPM	
System FAN Speed(FAN1)	0 RPM	
System FAN Speed(FAN2)	0 RPM	
Vcore (V)	1.34V	
VGMCH(V)	2.54V	
+ 5 V	5.10V	
+12 V	11.97V	
- 12 V	-12.34V	
- 5 V	-5.14V	
VBAT (V)	3.26V	
5VSB(V)	4.96V	
Shutdown Temperature	Disabled	
CPU Fan Failure Warning	Disabled	
Sys. Fan Failure Warning	Disabled	
Aux. Fan Failure Warning	Disabled	

CPU Warning Temperature

This field allows the user to set the temperature so that when the temperature is reached, the system sounds a warning. This function can help prevent damage to the system that is caused by overheating.

Temperatures/Fan Speeds/Voltages

These fields are the parameters of the hardware monitoring function feature of the motherboard. The values are read-only values as monitored by the system and show the PC health status.

Shutdown Temperature

This field allows the user to set the temperature by which the system automatically shuts down once the threshold temperature is reached. This function can help prevent damage to the system that is caused by overheating.

CPU/System/Aux Fan Failure Warning

When enabled, this field lets the system sounds an audible warning to the user that the CPU fan or chassis fan has malfunctioned.

Frequency/Voltage Control

This section shows the user how to configure the processor frequency.

Phoenix - AwardBIOS CMOS Setup Utility
Frequency/Voltage Control

Auto Detect DIMM/PCI Clk	Disabled	ITEM HELP
Spread Spectrum	Disabled	Menu Level

Auto Detect DIMM/PCI Clk

This field enables or disables the auto detection of the PCI clock.

Spread Spectrum

This field sets the value of the spread spectrum. The default setting is *Disabled*. This field is for CE testing use only.

Load Fail-Safe Defaults

This option allows you to load the troubleshooting default values permanently stored in the BIOS ROM. These default settings are non-optimal and disable all high-performance features.

Load Optimized Defaults

This option allows you to load the default values to your system configuration. These default settings are optimal and enable all high performance features.

Set Supervisor/User Password

These two options set the system password. Supervisor Password sets a password that will be used to protect the system and Setup utility. User Password sets a password that will be used exclusively on the system. To specify a password, highlight the type you want and press <Enter>. The Enter Password: message prompts on the screen. Type the password, up to eight characters in length, and press <Enter>. The system confirms your password by asking you to type it again. After setting a password, the screen automatically returns to the main screen.

To disable a password, just press the <Enter> key when you are prompted to enter the password. A message will confirm the password to be disabled. Once the password is disabled, the system will boot and you can enter Setup freely.

Save & Exit Setup

This option allows you to determine whether or not to accept the modifications. If you type “Y”, you will quit the setup utility and save all changes into the CMOS memory. If you type “N”, you will return to Setup utility.

Exit Without Saving

Select this option to exit the Setup utility without saving the changes you have made in this session. Typing “Y” will quit the Setup utility without saving the modifications. Typing “N” will return you to Setup utility.

Drivers Installation

This section describes the installation procedures for software and drivers under the Windows 2000 and Windows XP. The software and drivers are included with the CPU card. The contents of this section include the following:

Intel i915G Chipset Software Installation Utility	56
VGA Drivers Installation	58
Realtek AC97 Codec Audio Driver Installation	59
Intel PRO LAN Drivers Installation	60
Marvell LAN Controller Drivers Installation	61

IMPORTANT NOTE:

After installing your Windows operating system (Windows 2000/XP), you must install first the Intel® Chipset Software Installation Utility before proceeding with the drivers installation.

Intel i915G Chipset Software Installation Utility

The Intel® i915G Chipset Drivers should be installed first before the software drivers to enable Plug & Play INF support for Intel® chipset components. Follow the instructions below to complete the installation under Windows 2000/XP. (Before installing the Intel Chipset Software Installation Utility, update your system with Windows 2000 SP4 or Windows XP SP1A).

1. Insert the CD that comes with the motherboard and the screen below would appear. Click Intel Chipsets, click Intel I915G Chipset Drivers, click Intel(R) Chipset Software Installation Utility.



2. When the Welcome screen appears, click *Next* to continue.

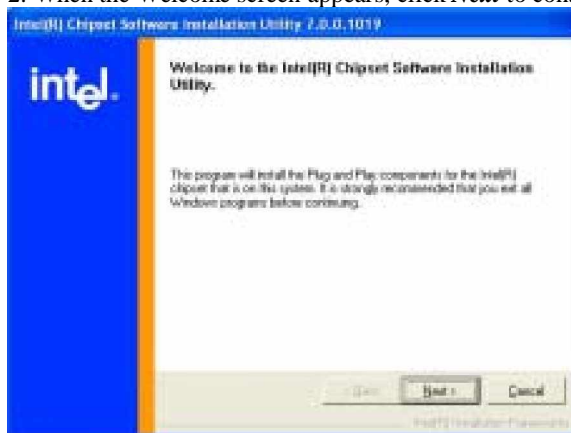

3. Click *Yes* to accept the software license agreement and proceed with the installation process.

4. In the Readme Information screen, click *Next* to continue the installation.

5. The Setup process is now complete. Click *Finish* to restart the computer and for changes to take effect.



VGA Drivers Installation

To install the Intel(R) 915G Chipset Family Graphics drivers, follow the steps below to proceed with the installation.

1. Insert the CD that comes with the motherboard and the screen below would appear. Click Intel Chipsets, click Intel I915G Chipset Drivers, click Intel(R) 915G Chipset Family Graphics drivers.



2. When the Welcome screen appears, click *Next* to continue.
3. Click *Yes* to agree with the license agreement and continue the installation.
4. Click *Finish* to restart the computer and for changes to take effect.

Realtek AC97 Codec Audio Driver Installation

Follow the steps below to install the Realtek AC97 Codec Audio Drivers.

1. Insert the CD that comes with the CPU card and the screen below would appear. Click Intel Chipsets, click Intel I915G Chipset Drivers, click Realtek AC97 Codec Audio Drivers to start the installation.



2. When the Welcome screen appears, click *Next* to continue.

3. Click *Continue Anyway* to continue.



4. Click *Finish* to restart the computer and for changes to take effect.

Intel PRO LAN Drivers Installation

Follow the steps below to complete the installation.

1. Insert the CD that comes with the CPU card and the screen below would appear. Click on LAN Card on the left side to make the LAN drivers selection. Click on Intel(R) PRO LAN Drivers.

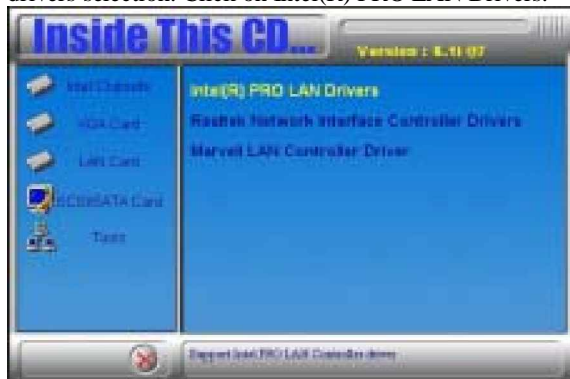

2. When prompted, click *Exit* for new settings to take effect.



Marvell LAN Controller Drivers Installation

Follow the steps below to complete the installation.

1. Insert the CD that comes with the CPU card and the screen below would appear. Click on LAN Card on the left side to make the LAN drivers selection. Click on Marvell LAN Controller Drivers.



2. When the Welcome screen appears, click *Next* to continue.
3. Click *Next* to agree with the license agreement and continue the installation.



4. On Readme Information screen, click *Next* to continue the installation.

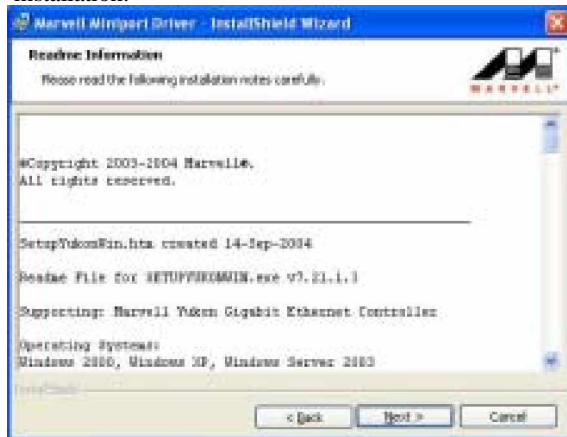

5. On Ready to Install the Program screen, click *Install* to continue the installation.

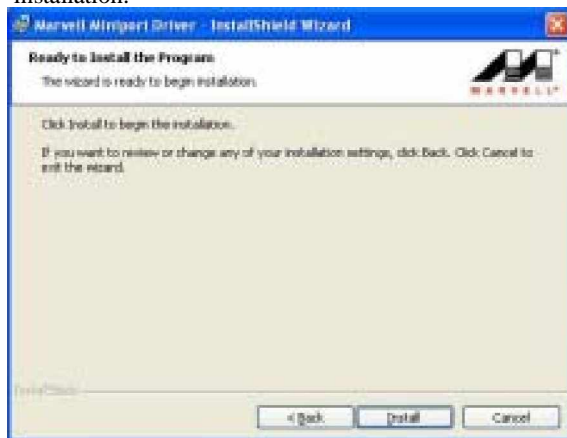

6. When prompted, click *Finish* for new settings to take effect.

Any advice or comments about our products and service, or anything we can help you with please don't hesitate to contact with us. We will do our best to support you for your products, projects and business

Global American Inc.

Address: 17 Hampshire Drive
Hudson, NH 03051

TEL: Toll Free (U.S. Only) 800-833-8999
(603) 886-3900

FAX: (603) 886-4545

Website: <http://www.globalamericaninc.com>

E-Mail: salesinfo@globalamericaninc.com

