



**User's Manual**

3301650

## REVISION HISTORY

Title	52 Intel Pentium M Socket 479 CPU card	
Revision Number	Description	Date of Issue
1.0	Initial release	March 2006

## COPYRIGHT NOTICE

The information in this document is subject to change without prior notice in order to improve reliability, design and function and does not represent a commitment on the part of the manufacturer.

In no event will the manufacturer be liable for direct, indirect, special, incidental, or consequential damages arising out of the use or inability to use the product or documentation, even if advised of the possibility of such damages.

This document contains proprietary information protected by copyright. All rights are reserved. No part of this manual may be reproduced by any mechanical, electronic, or other means in any form without prior written permission of the manufacturer.

## TRADEMARKS

IBM PC is a registered trademark of International Business Machines Corporation. INTEL is a registered trademark of INTEL Corporation. AMI is registered trademarks of American Megatrends Inc. Other product names mentioned herein are used for identification purposes only and may be trademarks and/or registered trademarks of their respective owners.

# Table of Contents

---

<b>1</b>	<b>INTRODUCTION.....</b>	<b>15</b>
1.1	3301650 CPU CARD OVERVIEW .....	16
1.1.1	<i>3301650 Model Variations.....</i>	<i>16</i>
1.1.2	<i>3301650 CPU Card Applications .....</i>	<i>16</i>
1.1.3	<i>3301650 CPU Card Benefits .....</i>	<i>16</i>
1.1.4	<i>3301650 CPU Card Features .....</i>	<i>17</i>
1.2	3301650 CPU CARD OVERVIEW .....	18
1.2.1	<i>3301650 CPU card Connectors.....</i>	<i>18</i>
1.2.2	<i>Technical Specifications.....</i>	<i>19</i>
<b>2</b>	<b>DETAILED SPECIFICATIONS .....</b>	<b>21</b>
2.1	COMPATIBLE GAI BACKPLANES .....	22
2.2	CPU SUPPORT.....	22
2.2.1	<i>Supported Pentium® M CPUs.....</i>	<i>22</i>
2.2.2	<i>Supported Celeron® M CPUs .....</i>	<i>23</i>
2.3	ONBOARD CHIPSETS .....	24
2.3.1	<i>Northbridge and Southbridge Chipsets .....</i>	<i>24</i>
2.3.2	<i>Intel® 915GM Northbridge Chipset.....</i>	<i>24</i>
2.3.3	<i>Intel® ICH6-M Southbridge Chipset.....</i>	<i>24</i>
2.4	DATA FLOW .....	25
2.5	GRAPHICS SUPPORT .....	26
2.5.1	<i>Intel® GMA 900.....</i>	<i>26</i>
2.5.2	<i>Analog VGA .....</i>	<i>26</i>
2.5.3	<i>Digital LVDS.....</i>	<i>26</i>
2.5.4	<i>Optional Digital Visual Interface (DVI) .....</i>	<i>26</i>
2.6	MEMORY SUPPORT .....	27
2.7	PCI BUS INTERFACE SUPPORT .....	27
2.8	ETHERNET CONNECTION.....	27
2.8.1	<i>PCI Express (PCI-E) Ethernet.....</i>	<i>27</i>
2.8.2	<i>GbE Ethernet .....</i>	<i>28</i>
2.9	DRIVE INTERFACES .....	28
2.9.1	<i>SATA Drives .....</i>	<i>28</i>

2.9.2	<i>HDD Interfaces</i> .....	29
2.9.3	<i>Floppy Disk Drive (FDD)</i> .....	29
2.10	SATA-II AND RAID FUNCTIONALITY (SATA3 AND SATA4 ONLY) .....	29
2.11	SERIAL PORTS .....	30
2.12	REAL TIME CLOCK.....	30
2.13	SYSTEM MONITORING.....	30
2.14	INFRARED DATA ASSOCIATION (IRDA) INTERFACE.....	30
2.15	USB INTERFACES.....	30
2.16	BIOS .....	31
2.17	OPERATING TEMPERATURE AND TEMPERATURE CONTROL.....	31
2.18	OPTIONAL AUDIO INTERFACE.....	31
2.19	POWER CONSUMPTION .....	31
2.20	PACKAGED CONTENTS AND OPTIONAL ACCESSORY ITEMS.....	32
2.20.1	<i>Package Contents</i> .....	32
2.20.2	<i>Special Items</i> .....	32
2.20.3	<i>Optional Accessory Items</i> .....	32
<b>3</b>	<b>CONNECTORS AND JUMPERS .....</b>	<b>35</b>
3.1	PERIPHERAL INTERFACE CONNECTORS .....	36
3.1.1	<i>3301650 CPU card Layout</i> .....	36
3.1.2	<i>Peripheral Interface Connectors</i> .....	37
3.1.3	<i>Rear Panel Connectors</i> .....	38
3.1.4	<i>Onboard Jumpers</i> .....	38
3.2	INTERNAL PERIPHERAL CONNECTORS.....	39
3.2.1	<i>FDD Connector</i> .....	39
3.2.2	<i>IDE Connectors</i> .....	41
3.2.3	<i>COM Ports</i> .....	42
3.2.4	<i>Parallel Port</i> .....	44
3.2.5	<i>Internal USB Connectors</i> .....	45
3.2.6	<i>Cooling Fan Connectors</i> .....	47
3.2.7	<i>Backplane to Mainboard ATX Connector</i> .....	48
3.2.8	<i>System Front Panel Connector</i> .....	50
3.2.9	<i>IrDA Connector</i> .....	51
3.2.10	<i>SATA Drive Connectors</i> .....	53
3.2.11	<i>DVI (Digital Visual Interface) Connector</i> .....	55
3.2.12	<i>LVDS Connector</i> .....	56

3.2.13	<i>Inverter Control</i> .....	58
3.2.14	<i>LAN State LED Connector</i> .....	59
3.2.15	<i>AC'97 Connector</i> .....	61
3.2.16	<i>Keyboard Connector</i> .....	62
3.2.17	<i>ATX-12V Power Source Connector</i> .....	64
3.3	EXTERNAL (REAR PANEL) CONNECTORS .....	65
3.3.1	<i>PS/2 Connector</i> .....	65
3.3.2	<i>USB Connector</i> .....	66
3.3.3	<i>Ethernet Connectors</i> .....	66
3.3.4	<i>VGA Connector</i> .....	67
3.4	ONBOARD JUMPERS .....	68
3.4.1	<i>LVDS Panel Voltage Selection Jumper</i> .....	70
3.4.2	<i>Reset CMOS Jumper</i> .....	70
3.4.3	<i>FSB Selection Jumper</i> .....	71
<b>4</b>	<b>INSTALLATION AND CONFIGURATION</b> .....	<b>73</b>
4.1	INSTALLATION CONSIDERATIONS .....	74
4.1.1	<i>Installation Notices</i> .....	74
4.2	UNPACKING .....	75
4.2.1	<i>Unpacking Precautions</i> .....	75
4.2.2	<i>Checklist</i> .....	75
4.3	3301650 CPU CARD INSTALLATION .....	76
4.3.1	<i>CPU Installation</i> .....	77
4.3.2	<i>Cooling Kit Installation</i> .....	79
4.3.3	<i>DIMM Module Installation</i> .....	81
4.3.3.1	<i>Purchasing the Memory Module</i> .....	81
4.3.3.2	<i>DIMM Module Installation</i> .....	82
4.3.4	<i>Peripheral Device Connection</i> .....	82
4.3.4.1	<i>IDE Disk Drive Connector (IDE1)</i> .....	82
4.3.4.2	<i>Floppy Drive Connector (FDD1)</i> .....	83
4.4	JUMPER CONFIGURATION .....	83
4.5	CHASSIS INSTALLATION .....	84
4.6	REAR PANEL CONNECTORS .....	84
4.6.1	<i>LCD Panel Connection</i> .....	84
4.6.2	<i>Ethernet Connection</i> .....	84
4.6.3	<i>USB Connection</i> .....	84

<b>5</b>	<b>AWARD BIOS SETUP .....</b>	<b>85</b>
5.1	INTRODUCTION .....	86
5.1.1	<i>Starting Setup</i> .....	86
5.1.2	<i>Using Setup</i> .....	86
5.1.3	<i>Getting Help</i> .....	87
5.1.4	<i>Unable to Reboot After Configuration Changes</i> .....	87
5.1.5	<i>Main BIOS Menu</i> .....	87
5.2	STANDARD CMOS FEATURES.....	90
5.2.1	<i>IDE Channel Master</i> .....	93
5.3	ADVANCED BIOS FEATURES.....	95
5.3.1	<i>CPU Feature</i> .....	103
5.3.2	<i>Hard Disk Boot Priority</i> .....	106
5.4	ADVANCED CHIPSET FEATURES.....	107
5.5	INTEGRATED PERIPHERALS .....	114
5.5.1	<i>OnChip IDE Device</i> .....	114
5.5.2	<i>OnBoard Device</i> .....	118
5.5.3	<i>SuperIO Device</i> .....	120
5.6	POWER MANAGEMENT SETUP.....	127
5.7	PNP/PCI CONFIGURATIONS .....	135
5.8	PC HEALTH STATUS .....	140
<b>6</b>	<b>SOFTWARE DRIVERS .....</b>	<b>143</b>
6.1	AVAILABLE SOFTWARE DRIVERS.....	144
6.2	CHIPSET DRIVER INSTALLATION.....	144
6.3	INTEL GRAPHICS MEDIA ACCELERATOR DRIVER .....	148
6.4	REALTEK AUDIO DRIVER INSTALLATION .....	151
6.5	MARVELL GIGABIT ETHERNET CONTROLLER DRIVER INSTALLATION .....	156
<b>A</b>	<b>BIOS CONFIGURATION OPTIONS .....</b>	<b>163</b>
A.1	BIOS CONFIGURATION OPTIONS .....	164
<b>B</b>	<b>WATCHDOG TIMER .....</b>	<b>169</b>
<b>C</b>	<b>ADDRESS MAPPING .....</b>	<b>173</b>
C.1	IO ADDRESS MAP .....	174
C.2	1ST MB MEMORY ADDRESS MAP .....	174
C.3	IRQ MAPPING TABLE.....	175

C.4	DMA CHANNEL ASSIGNMENTS .....	175
<b>D</b>	<b>EXTERNAL AC'97 AUDIO CODEC .....</b>	<b>177</b>
D.1	INTRODUCTION .....	178
D.2	PHYSICAL CONNECTION .....	179
D.3	DRIVER INSTALLATION.....	180
D.4	SOUND EFFECT CONFIGURATION .....	181
D.5	SOUND EFFECT .....	182
D.6	ENVIRONMENT SIMULATION .....	182
D.7	KARAOKE MODE.....	183
D.8	EQUALIZER SELECTION.....	184
D.9	SPEAKER CONFIGURATION .....	185
D.10	SPEAKER TEST .....	186
D.11	S/PDIF-IN & S/PDIF-OUT .....	187
D.12	CONNECTOR SENSING .....	188
D.13	HRTF DEMO.....	191
D.14	MICROPHONE EFFECT .....	191
D.15	GENERAL .....	192
<b>E</b>	<b>INDEX.....</b>	<b>193</b>

# List of Figures

---

Figure 1-1: 3301650 CPU card Overview.....	18
Figure 2-1: Data Flow Block Diagram.....	25
Figure 3-1: Connector and Jumper Locations .....	36
Figure 3-2: FDD Connector Location .....	40
Figure 3-3: IDE Connector Location.....	42
Figure 3-4: COM Port Locations .....	43
Figure 3-5: LPT Connector Location .....	45
Figure 3-6: USB Port Connector Location.....	46
Figure 3-7: Cooling Fan Connector Locations.....	48
Figure 3-8: ATXCTL1 Connector Locations .....	49
Figure 3-9: System Panel Connector Location .....	51
Figure 3-10: IrDA Connector Location .....	52
Figure 3-11: SATA Connector Locations.....	54
Figure 3-12: DVI1 Connector Location.....	56
Figure 3-13: LVDS LCD Panel Connection Port.....	58
Figure 3-14: J1 Inverter Control.....	59
Figure 3-15: J_LANLED Connector Locations .....	60
Figure 3-16: CN9 Connector Location.....	62
Figure 3-17: KB1 Connector Location.....	64
Figure 3-18: ATX Connector Location.....	64
Figure 3-19: 3301650 CPU card Rear Panel .....	65
Figure 3-20: PS/2 Pinout locations.....	66
Figure 3-21: RJ-45 Ethernet Connector .....	67
Figure 3-23: Jumper Locations.....	69
Figure 4-1: Make sure the CPU socket retention screw is unlocked.....	78
Figure 4-2: Lock the CPU Socket Retention Screw .....	79
Figure 4-3: Cooling Kit .....	79
Figure 4-4: Securing the Cooling Kit.....	80



Figure 4-5: Connect the cooling fan cable .....	81
Figure 6-1: Chipset Driver Installation Welcome Screen .....	145
Figure 6-2: Chipset Driver Installation License Agreement.....	146
Figure 6-3: Chipset Driver Readme File Information .....	147
Figure 6-4: Chipset Driver Installation Complete.....	148
Figure 6-5: GMA Driver Installation Welcome Screen.....	149
Figure 6-6: GMA Driver License Agreement.....	150
Figure 6-7: GMA Driver Installing Notice .....	150
Figure 6-8: GMA Driver Installation Complete .....	151
Figure 6-9: Audio Driver Install Shield Wizard Starting .....	152
Figure 6-10: Audio Driver Setup Preparation.....	152
Figure 6-11: Audio Driver Welcome Screen .....	153
Figure 6-12: Audio Driver Software Configuration .....	153
Figure 6-13: Audio Driver Digital Signal .....	154
Figure 6-14: Audio Driver Installation Begins .....	155
Figure 6-15: Audio Driver Installation Complete.....	156
Figure 6-16: Ethernet Controller Driver Install Shield Wizard Starting.....	157
Figure 6-17: Ethernet Controller Driver Installation Welcome Screen .....	157
Figure 6-18: Ethernet Driver License Agreement .....	158
Figure 6-19: GMA Driver Installing Notice .....	159
Figure 6-20: Ethernet Driver is Installed .....	160
Figure 6-21: Ethernet Driver Installation Confirmation .....	161

# List of Tables

---

Table 1-1: 3301650 Model Variations.....	16
Table 1-2: Technical Specifications .....	20
Table 2-1: Supported Pentium® M CPUs.....	23
Table 2-2: Supported Celeron® M CPUs.....	24
Table 2-3: Power Consumption .....	32
Table 3-1: Peripheral Interface Connectors.....	38
Table 3-2: Peripheral Interface Connectors.....	38
Table 3-3: Onboard Jumpers .....	39
Table 3-4: FDD Connector Pinouts.....	40
Table 3-5: IDE Connector Pinouts .....	41
Table 3-6: Internal COM Port Connector Pinouts .....	43
Table 3-7: LPT Connector Pinouts .....	44
Table 3-8: USB Port Connector Pinouts .....	46
Table 3-9: Cooling Fan Connector Pinouts .....	47
Table 3-10: CN7 Connector Pin Outs .....	49
Table 3-11: System Panel Connector Pinouts.....	50
Table 3-12: IrDA Connector Pinouts.....	52
Table 3-13: SATA Connector Pinouts .....	53
Table 3-14: DVI Connector Pinouts .....	55
Table 3-15: LVDS Connector Pinouts.....	57
Table 3-16: Inverter Connector Pinouts.....	59
Table 3-17: J_LANLED Connector Pinouts .....	60
Table 3-18: CN9 Connector Pinouts.....	61
Table 3-19: KB1 Connector Pinouts.....	63
Table 3-20: CN100 Connector Pinouts.....	64
Table 3-21: PS/2 Pinouts .....	66
Table 3-22: USB Connectors.....	66
Table 3-23: RJ-45 Ethernet Connector Pinouts.....	67
Table 3-24: RJ-45 Ethernet Connector LEDs.....	67

Table 3-25: VGA Connector Pinouts .....	68
Table 3-26: Jumpers.....	69
Table 3-27: JP1 Jumper Settings.....	70
Table 3-28: JP2 Jumper Settings.....	71
Table 3-29: JP3 Jumper Settings.....	72
Table 4-1: GAI Provided Cables.....	82
Table 5-1: BIOS Navigation Keys.....	87

# List of BIOS Menus

---

BIOS Menu 1: Award BIOS CMOS Setup Utility .....	88
BIOS Menu 2: Standard CMOS Features .....	90
BIOS Menu 3: IDE Channel Master .....	93
BIOS Menu 4: Advanced BIOS Features.....	96
BIOS Menu 5: CPU Feature .....	103
BIOS Menu 6: Hard Disk Boot Priority .....	106
BIOS Menu 7: Advanced Chipset Features .....	107
BIOS Menu 8: PCI Express Port Functions .....	111
BIOS Menu 9: Integrated Peripherals.....	114
BIOS Menu 10: Integrated Peripherals.....	115
BIOS Menu 11: OnBoard Device [Integrated Peripherals] .....	118
BIOS Menu 12: SuperIO Device [Integrated Peripherals].....	121
BIOS Menu 13: Power Management Setup.....	127
BIOS Menu 14: PnP/PCI Configurations .....	135
BIOS Menu 15: IRQ Resources .....	137
BIOS Menu 16: PC Health Status.....	140

# Glossary

---

AC '97	Audio Codec 97	HDD	Hard Disk Drive
ACPI	Advanced Configuration and Power Interface	IDE	Integrated Data Electronics
APM	Advanced Power Management	I/O	Input/Output
ARMD	ATAPI Removable Media Device	ICH4	I/O Controller Hub 4
ASKIR	Shift Keyed Infrared	L1	Cache Level 1 Cache
ATA	Advanced Technology Attachments	L2	Cache Level 2 Cache
BIOS	Basic Input/Output System	LCD	Liquid Crystal Display
CFII	Compact Flash Type 2	LPT	Parallel Port Connector
CMOS	Complementary Metal Oxide Semiconductor	LVDS	Low Voltage Differential Signaling
CPU	Central Processing Unit	MAC	Media Access Controller
Codec	Compressor/Decompressor	OS	Operating System
COM	Serial Port	PCI	Peripheral Connect Interface
DAC	Digital to Analog Converter	PIO	Programmed Input Output
DDR	Double Data Rate	PnP	Plug and Play
DIMM	Dual Inline Memory Module	POST	Power On Self Test
DIO	Digital Input/Output	RAM	Random Access Memory
DMA	Direct Memory Access	RAMDAC	RAM Digital to Analog Converter
EIDE	Enhanced IDE	SATA	Serial ATA
EIST	Enhanced Intel SpeedStep Technology	S.M.A.R.T	Self Monitoring Analysis and Reporting Technology
FDD	Floppy Disk Drive	SPD	Serial Presence Detect
FDC	Floppy Disk Connector	S/PDI	Sony/Philips Digital Interface
FFIO	Flexible File Input/Output	SDRAM	Synchronous Dynamic Random Access Memory
FIFO	First In/First Out	SIR	Serial Infrared
FSB	Front Side Bus	UART	Universal Asynchronous Receiver-transmitter
IrDA	Infrared Data Association	USB	Universal Serial Bus
		VGA	Video Graphics Adapter

**THIS PAGE IS INTENTIONALLY LEFT BLANK**

Chapter

1

# 1 Introduction

---

## 1.1 3301650 CPU card Overview

The PICMG 1.0 form factor 3301650 socket 479 Pentium M CPU card is fully equipped with a high performance processor and advanced multi-mode I/Os. The 3301650 is designed for system manufacturers, integrators, and VARs that want performance, reliability, and quality at a reasonable price.

### 1.1.1 3301650 Model Variations

The 3301650 has four model variations shown in **Table 1-1**.

Model Name	SATA-I		Interface (DVI)
3301650A	Two	None	None
3301650B	Two	Two	None
3301650C	Two	None	One
3301650D	Two	Two	One

**Table 1-1: 3301650 Model Variations**

### 1.1.2 3301650 CPU Card Applications

The 3301650 CPU card has been designed for use in industrial applications where board expansion is critical and operational reliability is essential.

### 1.1.3 3301650 CPU Card Benefits

Some of the 3301650 CPU card benefits include,

- „ providing access to multiple PCI and ISA expansion slots for easy system expansion
- „ operating reliably in harsh industrial environments with ambient temperatures as high as 60°C
- „ rebooting automatically if the BIOS watchdog timer detects that the system is no longer operating



### 1.1.4 3301650 CPU Card Features

Some of the 3301650 CPU card features are listed below:

- „ PICMG 1.0 compliant
- „ RoHS compliant
- „ Socket 479 Intel® Pentium M and Intel® Celeron M CPUs supported
- „ Maximum front side bus (FSB) speed of 533MHz supported
- „ Up to 2GB of 400MHz or 533MHz dual channel DDR2 memory supported
- „ Analog display with a maximum resolution of 2048x1536 pixels supported
- „ One dual channel LVDS port with maximum UXGA/WUXGA panel size supported
- „ One DVI interface with resolution from VGA to UXGA supported by two models (see **Table 1-1**)
- „ Two dual high performance PCI Express (PCI-E) Gigabit Ethernet (GbE) controllers supported
- „ SATA-I channels (SATA1 and SATA2) with transfer rates up to 150MB/s are supported
- „ Two SATA-II channels (SATA3 and SATA4) with transfer rates up to 300MB/s supported by two models (see **Table 1-1**)
- „ Seven USB 2.0 connectors supported
- „ RAID 0 and RAID 1 functionalities (SATA3 and SATA4 only) supported

## 1.2 3301650 CPU Card Overview

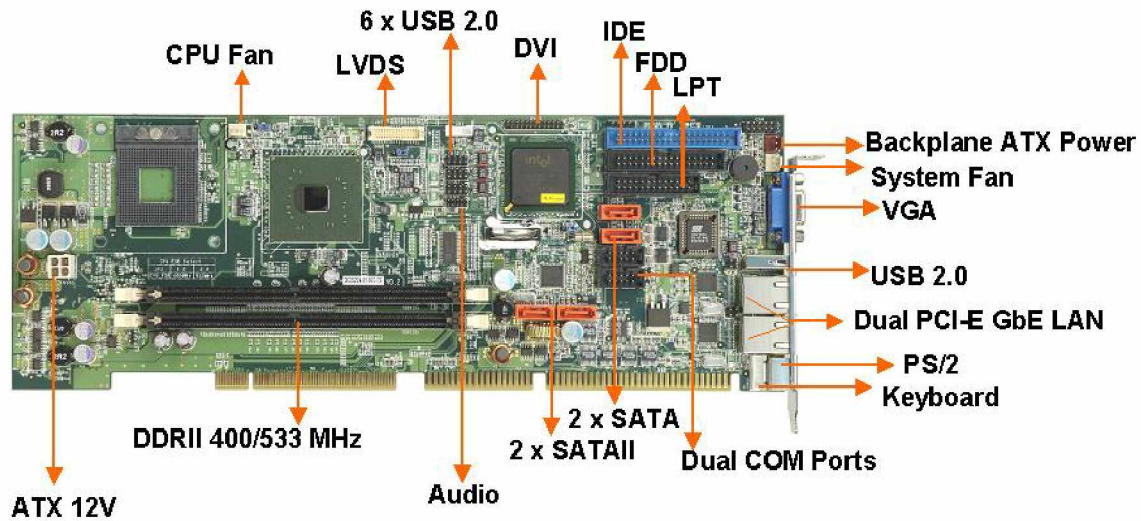

Figure 1-1: 3301650 CPU card Overview

### 1.2.1 3301650 CPU card Connectors

The 3301650 CPU card has the following connectors onboard:

- „ 1 x ATX 12V connector
- „ 1 x CPU cooling fan connector
- „ 1 x System cooling fan connector
- „ 1 x LVDS connector
- „ 1 x Inverter connector
- „ 1 x DVI connector (3301650C and 3301650D models only)
- „ 1 x IrDA connector
- „ 1 x HDD connector
- „ 1 x FDD connector
- „ 2 x RS-232 connectors
- „ 1 x Parallel port connector
- „ 1 x Front panel connector
- „ 1 x ATX backplane power connector
- „ 2 x LAN LED connectors
- „ 2 x SATA-I connectors
- „ 2 x SATA-II connectors (3301650B and 3301650D models only)

- „ 6 x USB connectors
- „ 1 x AC'97 connector
- „ 1 x Keyboard connector

The location of these connectors on the CPU card can be seen in **Figure 1-1**. These connectors are fully described in **Chapter 3**.

## 1.2.2 Technical Specifications

3301650 CPU card technical specifications are listed in **Table 1-2**. Detailed descriptions of each specification can be found in **Chapter 2 Detailed Specifications**.

SPECIFICATION	
<b>Supported CPUs</b>	<b>Intel® Pentium® M</b> <b>Intel® Celeron M</b>
<b>Chipsets</b>	<b>Northbridge: Intel® Alviso 915GM</b> <b>Southbridge: Intel® ICH6-M</b>
<b>I/O Controller</b>	<b>Intel® I/O Controller Hub 6-M (ICH6-M)</b>
<b>Graphics Support</b>	<b>Intel® Graphics Media Accelerator 900 (GMA 900)</b> <ul style="list-style-type: none"> <li>○ One VGA</li> <li>○ One DVI (see Table 1-1)</li> <li>○ One LVDS</li> </ul>
<b>Memory</b>	<b>Two DDR2 memory modules (Max. 2GB)</b>
<b>PCI Bus Interface</b>	<b>33MHz, Revision 2.3</b>
<b>ISA Bus Interface</b>	<b>Supports three fully compatible ISA slots without buffering</b> <b>ISA DMA and ISA Bus Master function are not supported</b>
<b>Serial ATA (SATA)</b>	<b>Two SATA-I channels (see Table 1-1) with 150MB/s transfer rates (SATA1 and SATA2)</b> <b>Two SATAII channels (see Table 1-1) with 300MB/s</b>

	transfer rates and RAID 0 and RAID 1 functions (SATA3 and SATA4)
<b>HDD Interface</b>	One IDE channel supports two Ultra ATA 100/66/33 devices
<b>Floppy Disk Drive (FDD)</b>	Supports FDD
<b>USB Interfaces</b>	Seven USB 2.0 connectors supported (Real X1, Front x6)
<b>Serial Ports</b>	Two serial port connectors (COM1 and COM2)
<b>Real Time Clock</b>	256-byte battery backed CMOS RAM
<b>Hardware Monitoring</b>	Cooling fans, temperature and system voltages
<b>Power Management</b>	Supports Advanced Configuration and Power Interface (ACPI) Specifications Revision 2.0
<b>Infrared Support</b>	One Infrared Data Association (IrDA) interface
<b>Ethernet</b>	Two PCI Express Gigabit Ethernet (PCI-E GbE) channels
<b>BIOS</b>	Phoenix Award BIOS
<b>Physical Dimensions</b>	12.2cm x 34.1cm (width x length)
<b>Operating Temperature</b>	Minimum: 0°C (32°F) Maximum: 60°C (140°F)
<b>Optional Audio Interfaces</b>	One Audio Codec '97 (AC'97) version 2.3 connector

Table 1-2: Technical Specifications

Chapter

2

# 2 Detailed Specifications

---

## 2.1 Compatible GAI Backplanes

The 3301650 CPU card is compatible with the all GAI PICMG1.0 backplanes. For more information on these backplanes, please visit the GAI website or contact your CPU card reseller or vendor.

## 2.2 CPU Support

---



### NOTE:

3301650 CPU cards are only compatible with Low Voltage (LV) and Ultra Low Voltage (ULV) CPUs in special customizations. If you wish to use either an LV or an ULV CPU, please speak to your GAI to discuss these customizations.

---

The 3301650 supports normal voltage, low voltage (LV) and ultra low voltage (ULV) mobile (M) Intel® Pentium® M processors and Intel® Celeron® M processors

### 2.2.1 Supported Pentium® M CPUs

**Table 2-1** lists the Intel® Pentium® M processors supported by the 3301650 CPU card. All the Intel® Pentium® M processors support Enhanced Intel SpeedStep® Technology.

Processor Number	Power	Architecture	L2 Cache	Speed	FSB	Execute Disable Bit
780	Normal	90nm	2MB	2.26GHz	533MHz	Yes
778	LV	90nm	2MB	1.60GHz	400MHz	Yes
770	Normal	90nm	2MB	2.13GHz	533MHz	Yes
765	Normal	90nm	2MB	2.10GHz	400MHz	No
758	LV	90nm	2MB	1.50GHz	400MHz	Yes
755	Normal	90nm	2MB	2GHz	400MHz	No
753	ULV	90nm	2MB	1.20GHz	400MHz	Yes

750	Normal	90nm	2MB	1.86GHz	533Mhz	Yes
745	Normal	90nm	2MB	1.80GHz	400MHz	No
740	Normal	90nm	2MB	1.73GHz	533MHz	Yes
738	LV	90nm	2MB	1.40GHz	400MHz	No
735	Normal	90nm	2MB	1.70GHz	400MHz	No
733J	ULV	90nm	2MB	1.10GHz	400MHz	Yes
733	ULV	90nm	2MB	1.10GHz	400MHz	No
730	Normal	90nm	2MB	1.60GHz	533MHz	Yes
725	ULV	90nm	2MB	1.60GHz	400MHz	No
723	ULV	90nm	2MB	1GHz	400MHz	No
718	LV	130nm	1MB	1.30GHz	400MHz	No

**Table 2-1: Supported Pentium® M CPUs**

### 2.2.2 Supported Celeron® M CPUs

**Table 2-2** lists the Intel® Celeron® M processors supported by the 3301650 CPU card.

Processor Number	Power	Architecture	L2 Cache	Speed	FSB	Execute Disable Bit
390	Normal	90nm	1MB	1.70GHz	400MHz	Yes
383	ULV	90nm	1MB	1GHz	400MHz	Yes
380	Normal	90nm	1MB	1.60GHz	400MHz	Yes
373	ULV	90nm	512KB	1GHz	400MHz	Yes
370	Normal	90nm	1MB	1.50GHz	400MHz	Yes
360J	Normal	90nm	1MB	1.40GHz	400MHz	Yes
360	Normal	90nm	1MB	1.40GHz	400MHz	No
353	ULV	90nm	512KB	900MHz	400MHz	No
350J	Normal	90nm	1MB	1.30GHz	400MHz	Yes
350	Normal	90nm	1MB	1.30GHz	400MHz	No

340	Normal	130nm	512KB	1.50GHz	400MHz	No
333	ULV	130nm	512KB	900MHz	400MHz	No
330	Normal	130nm	512KB	1.40GHz	400MHz	No
320	Normal	130nm	512KB	1.30GHz	400MHz	No
310	Normal	130nm	512KB	1.20GHz	400MHz	No

Table 2-2: Supported Celeron® M CPUs

## 2.3 Onboard Chipsets

### 2.3.1 Northbridge and Southbridge Chipsets

The following chipsets are preinstalled on the board:

- „ **Northbridge:** Intel® 915GM
- „ **Southbridge:** Intel® ICH6-M

The following two sections (**Section 2.3.2** and **Section 2.3.3**) list some of the features of the Intel® 915GM and the Intel® ICH6-M chipsets. For more information on these two chipsets please refer to the Intel website.

### 2.3.2 Intel® 915GM Northbridge Chipset

The Intel® 915GM northbridge chipset comes with the following features:

- „ Supports 533MHz or 400MHz System Bus
- „ Implements Intel® Graphics Media Accelerator 900 (GMA 900)
- „ Implements PCI Express (PCI-E) technology
- „ Supports DDR2 DIMM memory modules

### 2.3.3 Intel® ICH6-M Southbridge Chipset

The Intel® ICH6-M southbridge chipset comes with the following features:

- „ Complies with PCI Express Base Specification Revision 1.0a
- „ Complies with PCI Local Bus Specification Revision 2.3 and supports 33MHz PCI operation



- „ Supports ACPI power management
- „ Integrates a SATA controller that controls two SATA-I channels (SATA1 and SATA2) with transfer rates up to 150MB/s and independent DMA operation
- „ Supports Ultra ATA 100/66/33 with an integrated IDE controller
- „ Supports eight USB 2.0 ports but only seven are implemented on the 3301650 CPU card.
- „ Supports AC'97 Revision 2.3 Specifications
- „ Complies with System Management Bus Interface (SMBus) Specification Version 2.0

## 2.4 Data Flow

Figure 2-1 shows the data flow between the user-installed socket 479 CPU, the two onboard chipsets and other components installed on the CPU card are described in the following sections of this chapter.

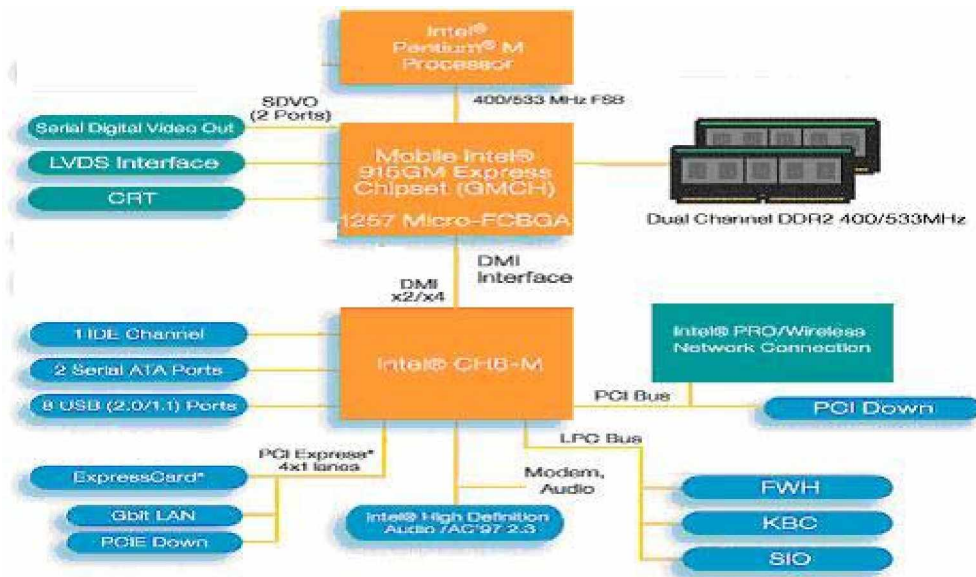

Figure 2-1: Data Flow Block Diagram

## 2.5 Graphics Support

### 2.5.1 Intel® GMA 900

The Intel® GMA 900 integrated on the Intel® 915GM chipset has the following features.

- „ 333MHz 2D display core:
- „ 1.05V VCC: 133/190/200MHz
- „ 333MHz 3D Render core:
- „ 1.05V VCC: 166/190/200MHz
- „ Supports Intel® Smart 2D Display Technology
- „ Support Intel® Dual Display Technology
- „ Supports 3D Graphics Engine with Direct X 9.0/OpenGL 2.0
- „ Supports Dynamic Video Memory Technology 3.0

### 2.5.2 Analog VGA

The onboard analog VGA has the following features.

- „ Supports 400MHz, 24-bit RAMDAC (RAM digital to analog converter)
- „ Supports displays with resolutions up to 2048x1536 pixels

### 2.5.3 Digital LVDS

The onboard digital LVDS has the following features.

- „ Supports dual channel LVDS 2x18 bpp for TFT Panels up to UXGA/WUXGA
- „ Compliant with ANSI/TIA/EIA-644-2001 SPEC.

### 2.5.4 Optional Digital Visual Interface (DVI)

The optional DVI has the following features.

- „ Supports DVI 1.0 up to UXGA with Silicon Image PanelLink® Technology

## 2.6 Memory Support

The 3301650 CPU has two 240-pin dual inline memory module (DIMM) sockets and supports up to two unbuffered DDR2 DIMMs with the following specifications:

- „ **Maximum RAM:** 2GB (1GB module in each slot)
- „ **DIMM Transfer Rates:** 533MHz, 400MHz
- „ Up to 8.5 GB/sec memory bandwidth

## 2.7 PCI Bus Interface Support

The PCI bus on the 3301650 CPU card has the following features:



### NOTE:

The 3301650 does not support ISA DMA and ISA Bus Master function. Before purchasing your ISA device, please confirm with your vendor that your ISA card is supported by the CPU board.

- 
- „ 33MHz Revision 2.3 is implemented
  - „ Up to four external bus masters are supported
  - „ 2.X ISA bus interface supported
  - „ Three fully compatible ISA slots without buffering supported

## 2.8 Ethernet Connection

### 2.8.1 PCI Express (PCI-E) Ethernet

The PCI-E implemented on the Intel® ICH6-M southbridge chipset connects directly to two GbE controllers (Marvell Yukon 88E8053) with a concurrent bandwidth of 5Gb/s (2.5Gb/s in each direction).

### 2.8.2 GbE Ethernet

The two GbE controllers (Marvell Yukon 88E8053) on the 3301650 CPU card connect to two 10/100/1000Mb/s Ethernet RJ-45 LAN ports on the rear panel. The GbE controllers come with the following features:

- „ Dual 1Gb/s external LAN connectivity
- „ Marvell Virtual Cable Tester (VCT) technology
- „ Wake-on-LAN support

## 2.9 Drive Interfaces

The 3301650A and 3301650C models support the following drive interfaces:

- „ 2 x SATA-I drives
- „ 2 x IDE devices
- „ 1 x FDD

The 3301650B and 3301650D models support the following drive interfaces:

- „ 2 x SATA-I drives
- „ 2 x SATA-II drives (Silicon Image Sil3132 chipset supports SATA3/SATA4)
- „ 2 x IDE devices
- „ 1 x FDD

### 2.9.1 SATA Drives

The 3301650A and 3301650C models support the following SATA drive interfaces:

- „ 2 x first generation SATA-I drives with transfer rates up to 150MB/s with the ICH6-M southbridge chipset

The 3301650B and 3301650D models support the following SATA drive interfaces:

- „ 2 x first generation SATA-I drives with transfer rates up to 150MB/s with the

- ICH6-M southbridge chipset
- „ 2 x second generation SATA-II drives with transfer rates up to 300MB/s with the Silicon Image Sil3132 chipset

### 2.9.2 HDD Interfaces

The IDE controller on the ICH6-M southbridge chipset integrated on the 3301650CPU card supports up to two HDDs with the following specifications:

- „ Supports PIO IDE transfers up to 16MB/s
- „ Supports the following Ultra ATA devices:
  - „ **Ultra ATA/33**, with data transfer rates up to 33MB/s
  - „ **Ultra ATA/66**, with data transfer rates up to 66MB/s
  - „ **Ultra ATA/100**, with data transfer rates up to 100MB/s

### 2.9.3 Floppy Disk Drive (FDD)

The 3301650 CPU card supports a single FDD. The following FDD formats are compatible with the board.

- „ 5.25": 360KB and 1.2MB
- „ 3.5": 720KB, 1.44MB and 2.88MB

## 2.10 SATA-II and RAID Functionality (SATA3 and SATA4 only) Two

SATA-II channels and their associated RAID functionality are only available on the 3301650B and 3301650D models. These models come with a single onboard Sil 3132 PCI-E to 2-ports SATA-II host controller. The Sil3132 supports the following SATA-II features:

- „ SATA-II transfer speeds up to 3.0Gb/s
- „ Native Command Queuing,
- „ Port multipliers with FIS-based switching
- „ Programmable output signal swing strengths for longer external cables or extended backplanes,
- „ Hot plugging,
- „ Enclosure management
- „ ATAPI device support

The SATAII host controller also allows users to store their data in RAID 0 (disk striping) and RAID 1 (disk mirroring) configurations.

### 2.11 Serial Ports

The 3301650 CPU card has two high-speed UART serial ports, configured as COM1 and COM2. The serial ports have the following specifications.

- „ 16C550 UART with 16-byte FIFO buffer
- „ 115.2Kbps transmission rate

### 2.12 Real Time Clock

256-byte battery backed CMOS RAM

### 2.13 System Monitoring

The 3301650 CPU card is capable of self-monitoring various aspects of its operating status including:

- „ CPU, chipset, and battery voltage, +3.3V, +5V, and +12V
- „ RPM of cooling fans
- „ CPU and board temperatures (by the corresponding embedded sensors)

### 2.14 Infrared Data Association (IrDA) Interface

The 3301650 CPU card IrDA supports the following interfaces.

- „ Serial Infrared (SIR)
- „ Shift Keyed Infrared (ASKIR)

If you want to use the IrDA port, you have to configure SIR or ASKIR mode in the BIOS under **Super IO devices**. The normal RS-232 COM 2 will be disabled.

### 2.15 USB Interfaces

The 3301650 CPU card has seven USB interfaces, six internal and one external. The USB interfaces support USB2.0.

## 2.16 BIOS

The 3301650 CPU card uses a licensed copy of Phoenix Award BIOS. The features of the flash BIOS used are listed below:

- „ SMIBIOS (DMI) compliant
- „ Console redirection function support
- „ PXE (Pre-Boot Execution Environment ) support
- „ USB booting support

## 2.17 Operating Temperature and Temperature Control

The maximum and minimum operating temperatures for the 3301650 CPU card are listed below.

- „ Minimum Operating Temperature: 0°C (32°F)
- „ Maximum Operating Temperature: 60°C (140°F)

A cooling fan and heat sink must be installed on the CPU. Thermal paste must be smeared on the lower side of the heat sink before it is mounted on the CPU. Heat sinks are also mounted on the northbridge and southbridge chipsets to ensure the operating temperature of these chips remain low.

## 2.18 Optional Audio Interface

The 3301650 CPU card does not come with an onboard Codec but the Intel ICH6 chipset has an Audio Codec (AC'97) controller. A connector on the CPU card can be used to connect the ICH6 audio controllers to an external Codec.

## 2.19 Power Consumption

**Table 2-3** shows the power consumption parameters for the 3301650 CPU card when a 2GHz Pentium® M processor with a 533MHz FSB is running with 512MB, DDR400 SDRAM memory modules.

## 3301650 CPU Card

Voltage	Current
+5Vsb	0.93A
+5V	3.6A
+12V	2.08A

**Table 2-3: Power Consumption**

## 2.20 Packaged Contents and Optional Accessory Items

### 2.20.1 Package Contents

When you unpack the 3301650 CPU card you should find the following components.

- „ 1 x 3301650 single board computer
- „ 1 x mini jumper pack
- „ 1 x ATA 66/100 flat cable
- „ 2 x SATA cables
- „ 1 x SATA power cable
- „ 1 x Keyboard/ PS2 mouse Y cable
- „ 1 X RS-232 cable
- „ 1 x ATX-12V cable
- „ 1 x USB cable
- „ 1 x Utility CD
- „ 1 x QIG (quick installation guide)

### 2.20.2 Special Items

The following additional items are shipped with the 3301650B and 3301650D CPU card models.

- „ 2 x SATA cables
- „ 1 x SATA power cables

### 2.20.3 Optional Accessory Items

The items shown in the list below are separately purchased optional accessory items.

- „ DVI cable



- „ Audio Kit
- „ CPU Cooler
- „ FDD cable
- „ LPT cable

**THIS PAGE IS INTENTIONALLY LEFT BLANK**

Chapter

**3**

# **3 Connectors and Jumpers**

---

### 3.1 Peripheral Interface Connectors

The locations of the peripheral interface connectors are shown in **Section 3.1.1**. A complete list of all the peripheral interface connectors can be seen in **Section 3.1.2**.

#### 3.1.1 3301650 CPU card Layout

**Figure 3-1** shows the onboard peripheral connectors, backplane peripheral connectors and onboard jumpers.

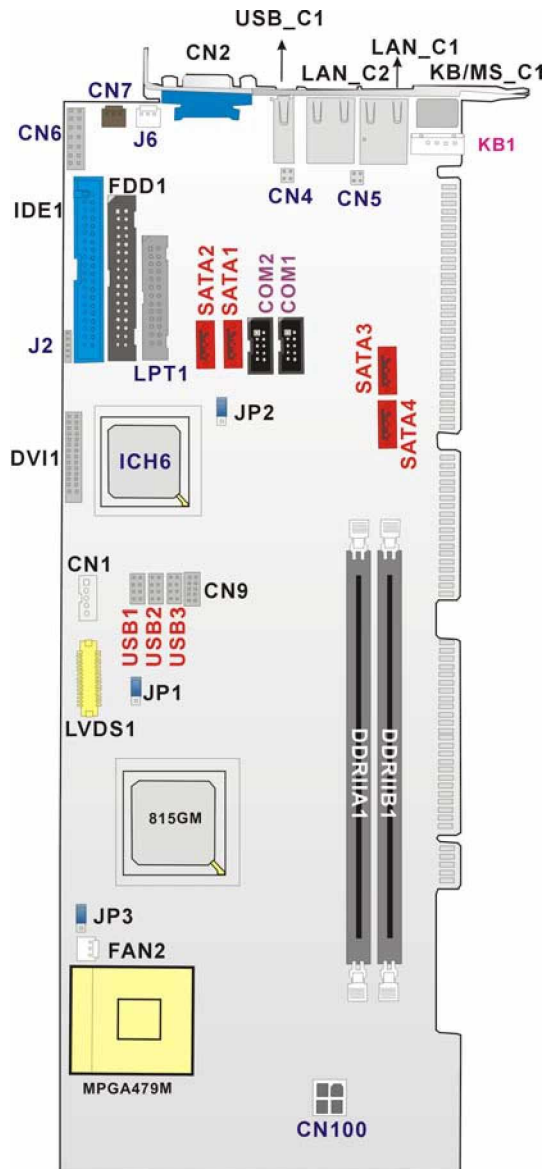

**Figure 3-1: Connector and Jumper Locations**

### 3.1.2 Peripheral Interface Connectors

**Table 3-1** lists the peripheral interface connectors on the 3301650 CPU card. Detailed descriptions of these connectors can be found in **Section 3.2** on **page 39**.

Label	Connector	pe
FDD1	FDD connector	34-pin header
IDE1	HDD connector	40-pin header
COM1	Serial communications connector	5-pin header
COM2	Serial communications connector	5-pin header
LPT1	Parallel port connector	26-pin header
SATA 1	SATA-I drive port (150MB/s) (see Table 1-1)	SATA-I disk drive port
SATA 2	SATA-I drive port (150MB/s) (see Table 1-1)	SATA-I disk drive port
SATA 3	SATA-II drive port (300MB/s) (see Table 1-1)	SATA-II disk drive port
SATA 4	SATA-II drive port (300MB/s) (see Table 1-1)	SATA-II disk drive port
LVDS1	Low Voltage Differential Signaling (LVDS) connector	30-pin header
CN1	LCD Backlight Inverter connector	5-pin header
CN100	ATX 12V connector	4-pin header
FAN2	CPU cooling fan connector	3-pin header
USB1	USB connector for 2 USB devices	8-pin header
USB2	USB connector for 2 USB devices	8-pin header
USB3	USB connector for 2 USB devices	8-pin header
CN9	Optional AC'97 Audio CODEC connector	10-pin header
DVI1	DVI connector (see Table 1-1)	26-pin header
J2	Infrared	5-pin header

CN6	Front Panel connector connects to chassis front panel power and reset buttons as status LEDs	12-pin header
CN7	ATX_PS_ON connector connects the CPU card to the backplane	3-pin header
J6	System fan connector	3-pin header
CN4	RJ-45 LED Connector	4-pin header
CN5	RJ-45 LED Connector	4-pin header
KB1	Keyboard connector	5-pin header

Table 3-1: Peripheral Interface Connectors

### 3.1.3 Rear Panel Connectors

Table 3-2 lists the rear panel connectors on the 3301650 CPU card. Detailed descriptions of these connectors can be found in **Section 3.3** on page 65.

Label	Connector	Type
KB/MS_C1	Keyboard or Mouse connector	PS/2
LAN_C1	Ethernet connector	RJ-45
LAN_C2	Ethernet connector	RJ-45
USB_C1	USB Connector	USB Port
CN2	VGA Connector	15-pin VGA connector

Table 3-2: Peripheral Interface Connectors

### 3.1.4 Onboard Jumpers

Table 3-3 lists the onboard jumpers. Detailed descriptions of these jumpers can be found in **Section 3.4** on page 68.

Label	Connector	pe
JP1	LVDS Panel Voltage Select	3-pin header
JP2	Clear CMOS	3-pin header
JP3	FSB Select	3-pin header

Table 3-3: Onboard Jumpers

## 3.2 Internal Peripheral Connectors

Internal peripheral connectors are found on the CPU card and are only accessible when the CPU card is outside of the chassis. This section has complete descriptions of all the internal, peripheral connectors on the 3301650 CPU card.

### 3.2.1 FDD Connector

<b>CN Label:</b>	<b>FDD1</b>
<b>CN Type:</b>	<b>2x17 pin header</b>
<b>CN Location:</b>	<b>See Figure 3-2</b>
<b>CN Pinouts:</b>	<b>See Table 3-4</b>

The 3301650 is shipped with a 34-pin daisy-chain drive connector cable. This cable can be connected to the FDD connector.

PIN	DESCRIPTION	PIN	
1	GND	2	REDUCE WRITE
3	GND	4	N/C
5	N/C	6	N/C
7	GND	8	INDEX#
9	GND	10	MOTOR ENABLE A#
11	GND	12	DRIVE SELECT B#
13	GND	14	DRIVE SELECT A#
15	GND	16	MOTOR ENABLE B#
17	GND	18	DIRECTION#

19	GND	20	STEP#
21	GND	22	WRITE DATA#
23	GND	24	WRITE GATE#
25	GND	26	TRACK 0#
27	GND	28	WRITE PROTECT#
29	GND	30	READ DATA#
31	GND	32	SIDE 1 SELECT#
33	GND	34	DISK CHANGE#

Table 3-4: FDD Connector Pinouts

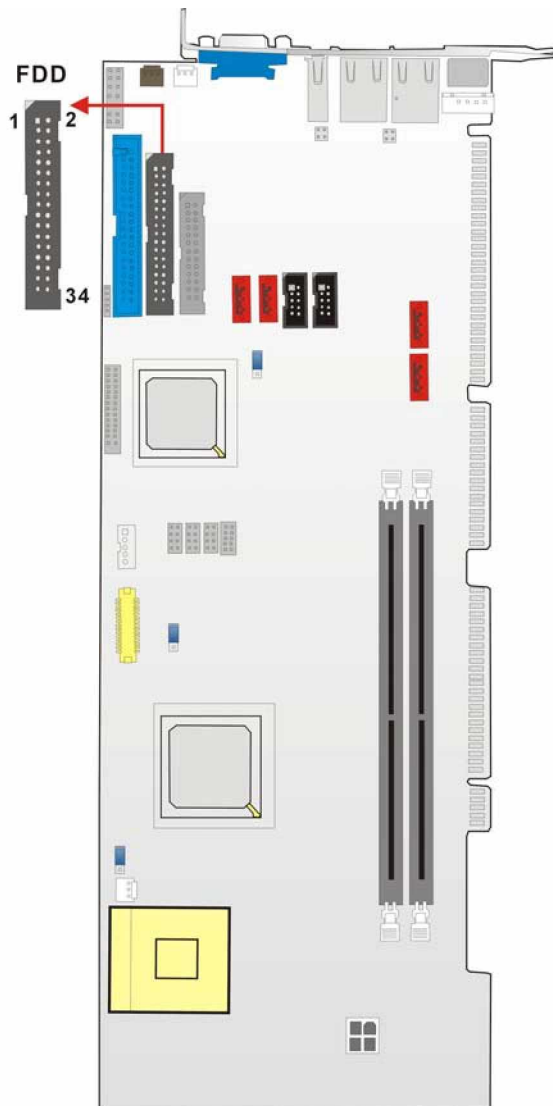

Figure 3-2: FDD Connector Location



### 3.2.2 IDE Connectors

- CN Label:** IDE1
- CN Type:** 2x20 pin header
- CN Location:** See Figure 3-3
- CN Pinouts:** See Table 3-5

One IDE connector provides connectivity for two IDE devices.

<b>PIN</b>	<b>DESCRIPTION</b>		<b>DESCRIPTION</b>
<b>1</b>	RESET#	<b>2</b>	GND
<b>3</b>	DATA 7	<b>4</b>	DATA 8
<b>5</b>	DATA 6	<b>6</b>	DATA 9
<b>7</b>	DATA 5	<b>8</b>	DATA 10
<b>9</b>	DATA 4	<b>10</b>	DATA 11
<b>11</b>	DATA 3	<b>12</b>	DATA 12
<b>13</b>	DATA 2	<b>14</b>	DATA 13
<b>15</b>	DATA 1	<b>16</b>	DATA 14
<b>17</b>	DATA 0	<b>18</b>	DATA 15
<b>19</b>	GND	<b>20</b>	N/C
<b>21</b>	IDE DRQ	<b>22</b>	GND
<b>23</b>	IOW#	<b>24</b>	GND
<b>25</b>	IOR#	<b>26</b>	GND
<b>27</b>	IDE CHRDY	<b>28</b>	BALE – DEFAULT
<b>29</b>	IDE DACK	<b>30</b>	GND
<b>31</b>	INTERRUPT	<b>32</b>	N/C
<b>33</b>	SA1	<b>34</b>	PDIAG#
<b>35</b>	SA0	<b>36</b>	SA2
<b>37</b>	HDC CS0#	<b>38</b>	HDC CS1#
<b>39</b>	HDD ACTIVE#	<b>40</b>	GND

**Table 3-5: IDE Connector Pinouts**

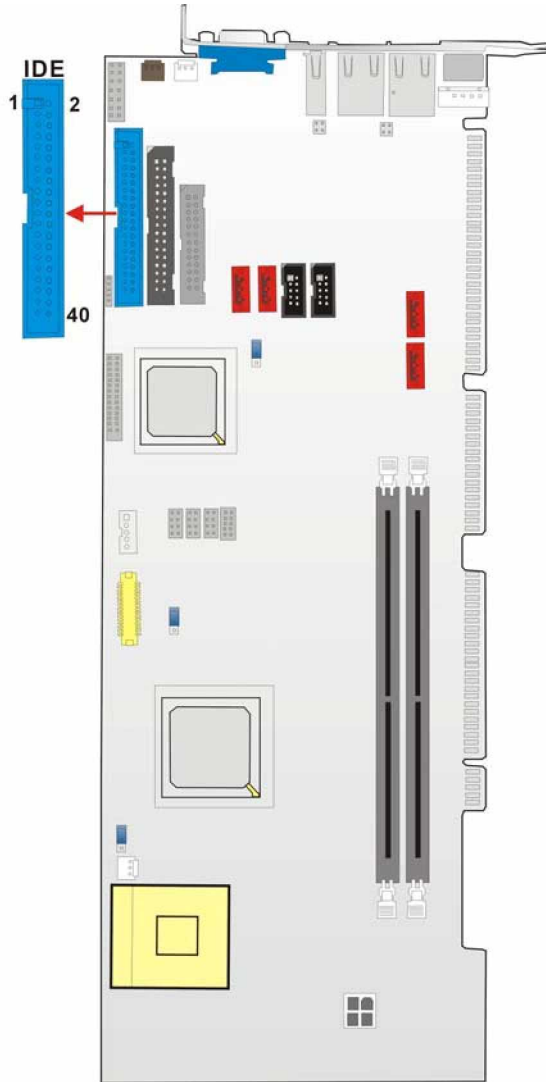

Figure 3-3: IDE Connector Location

### 3.2.3 COM Ports

- CN Label:** COM1, COM2
- CN Type:** 2x5 pin headers
- CN Location:** See Figure 3-4
- CN Pinouts:** See Table 3-6

The WSB-9150 CPU card has two internal high-speed UART connectors accessed through a 10-pin cable connector.

PIN	DESCRIPTION		
1	DATA CARRIER DETECT (DCD)	6	DATA SET READY (DSR)
2	RECEIVE DATA (RXD)	7	REQUEST TO SEND (RTS)
3	TRANSMIT DATA (TXD)	8	CLEAR TO SEND (CTS)
4	DATA TERMINAL READY (DTR)	9	RING INDICATOR (RI)
5	GND (GND)	10	GND (GND)

Table 3-6: Internal COM Port Connector Pinouts

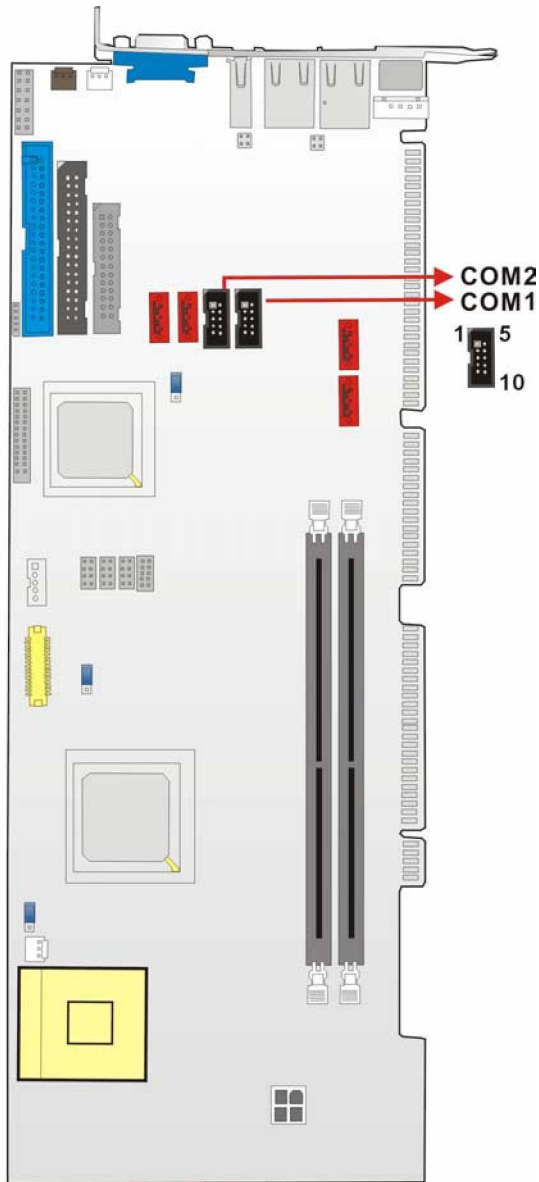

Figure 3-4: COM Port Locations

### 3.2.4 Parallel Port

- CN Label:** LPT1
- CN Type:** 2x13 pin header
- CN Location:** See Figure 3-5
- CN Pinouts:** See Table 3-7

The parallel port connector is usually connected to a printer or other parallel device with a 26-pin flat-cable connector.

PIN	DESCRIPTION		
1	STROBE#	14	AUTO FORM FEED #
2	DATA0	15	ERROR#
3	DATA1	16	INITIALIZE#
4	DATA2	17	PRINTER SELECT LN#
5	DATA3	18	GND
6	DATA4	19	GND
7	DATA5	20	GND
8	DATA6	21	GND
9	DATA7	22	GND
10	ACKNOWLEDGE#	23	GND
11	BUSY	24	GND
12	PAPER EMPTY	25	GND
13	PRINTER SELECT		

**Table 3-7: LPT Connector Pinouts**

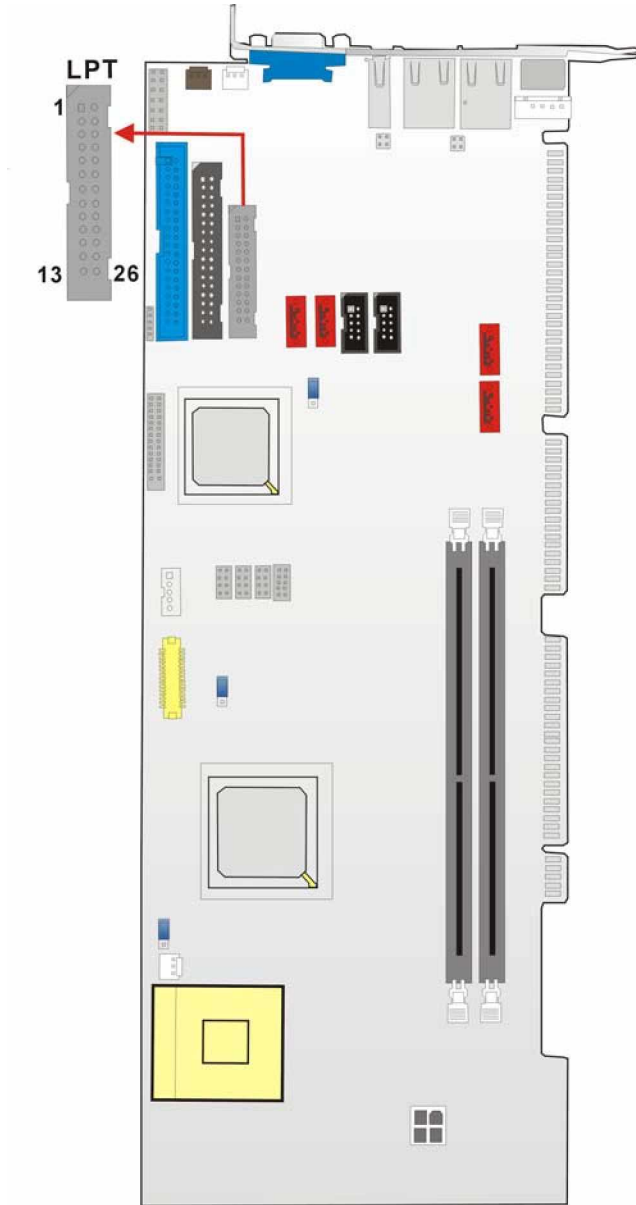

Figure 3-5: LPT Connector Location

### 3.2.5 Internal USB Connectors

CN Label:	USB1, USB2, USB3
CN Type:	2x4 pin header
CN Location:	See Figure 3-6
CN Pinouts:	See Table 3-8

Three 2x4 pin connectors provide connectivity to six USB 2.0 ports. An additional USB port is found on the rear panel. The USB ports are used for I/O bus expansion.

PIN	DESCRIPTION		
1	USB Power	2	GND
3	USBPX-	4	USBPX-
5	USBPX+	6	USBPX+
7	GND	8	USB Power

Table 3-8: USB Port Connector Pinouts

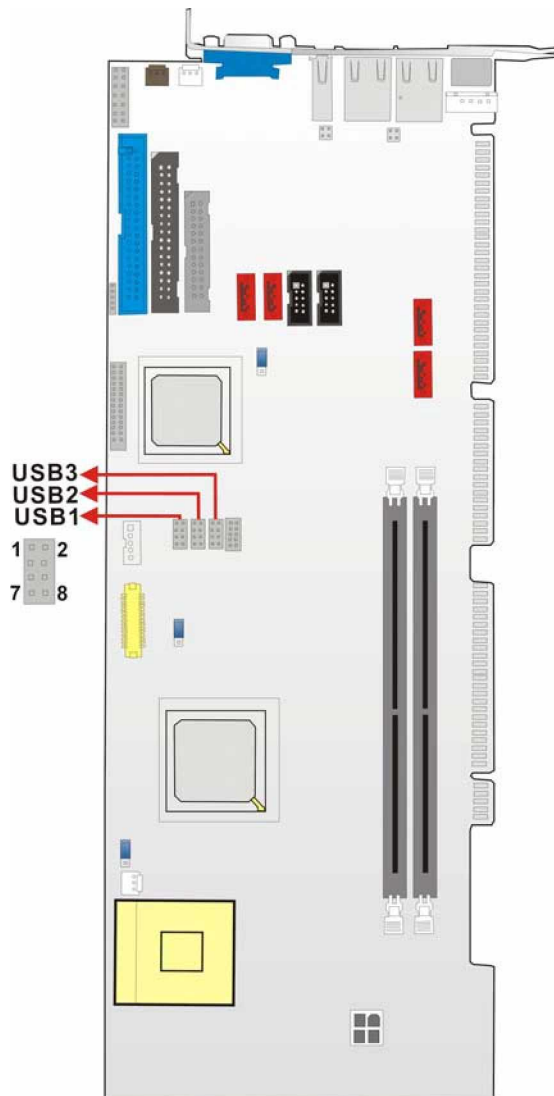

Figure 3-6: USB Port Connector Location

### 3.2.6 Cooling Fan Connectors

- CN Label:** FAN2, J6
- CN Type:** 1x3 pin header
- CN Location:** See Figure 3-7
- CN Pinouts:** See Table 3-9

The FAN2 CPU cooling fan connector and the J6 system cooling fan connector provide a 12V, 500mA current to the cooling fan. The connector has a "rotation" pin to get rotation signals from fans and notify the system so the system BIOS can recognize the fan speed. Please note that only certain fans can issue the rotation signals.

<b>PIN</b>	<b>DESCRIPTION</b>
1	Sense Pulse
2	+12V
3	GND

**Table 3-9: Cooling Fan Connector Pinouts**

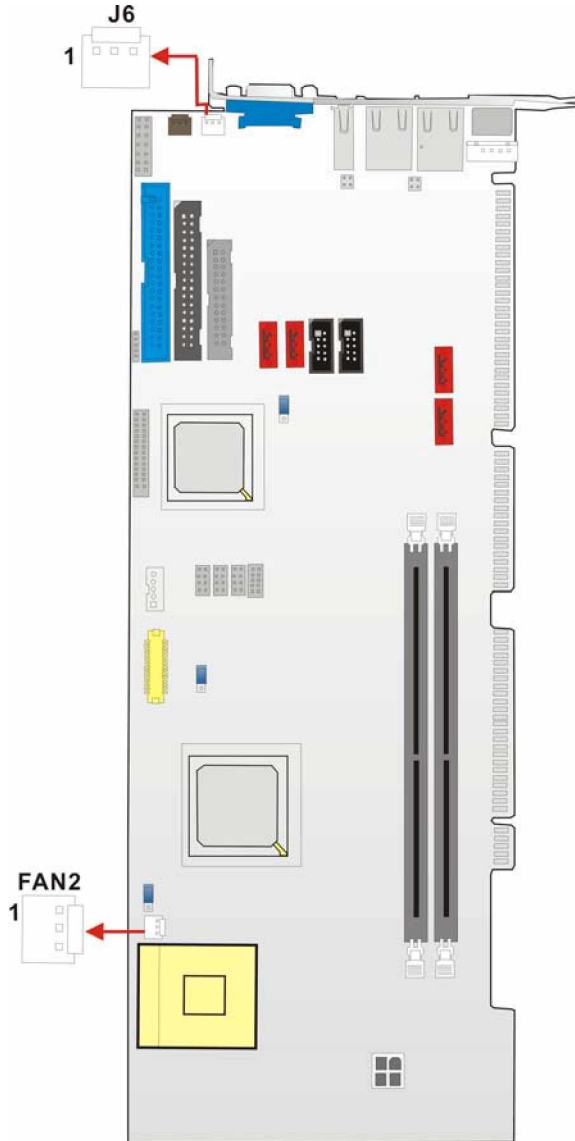

Figure 3-7: Cooling Fan Connector Locations

### 3.2.7 Backplane to Mainboard ATX Connector

<b>CN Label:</b>	<b>CN7</b>
<b>CN Type:</b>	<b>1x3 pin header</b>
<b>CN Location:</b>	<b>See Figure 3-8</b>
<b>CN Pinouts:</b>	<b>See Table 3-10</b>

Connects a power source from a backplane with an ATX Connector.



PIN NO.	DESCRIPTION
1	ATX_5VSB
2	ATX_PS_ON
3	GND

Table 3-10: CN7 Connector Pin Outs

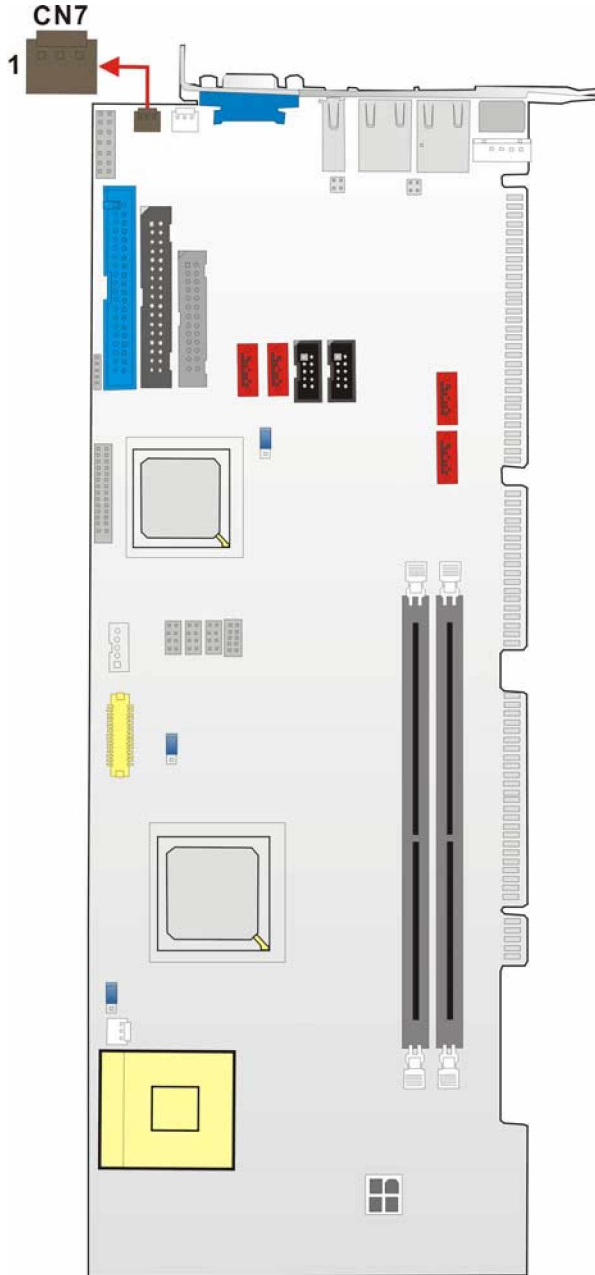

Figure 3-8: ATXCTL1 Connector Locations

### 3.2.8 System Front Panel Connector

- CN Label:** CN6
- CN Type:** 2x6 pin header
- CN Location:** See Figure 3-9
- CN Pinouts:** See Table 3-11

The system panel connector connects to:

- „ the system chassis front panel LEDs
- „ the chassis speaker
- „ the power switch
- „ the reset button.

PIN	DESCRIPTION		
1	POWER LED (-)	2	SPEAKER+
3	POWER LED (+)	4	N/C
5	Power Button (+)	6	N/C
7	Power Button (-)	8	SPEAKER-
9	HDD LED (-)	10	Reset Button (+)
11	HDD LED(+)	12	Reset Button (-)

**Table 3-11: System Panel Connector Pinouts**

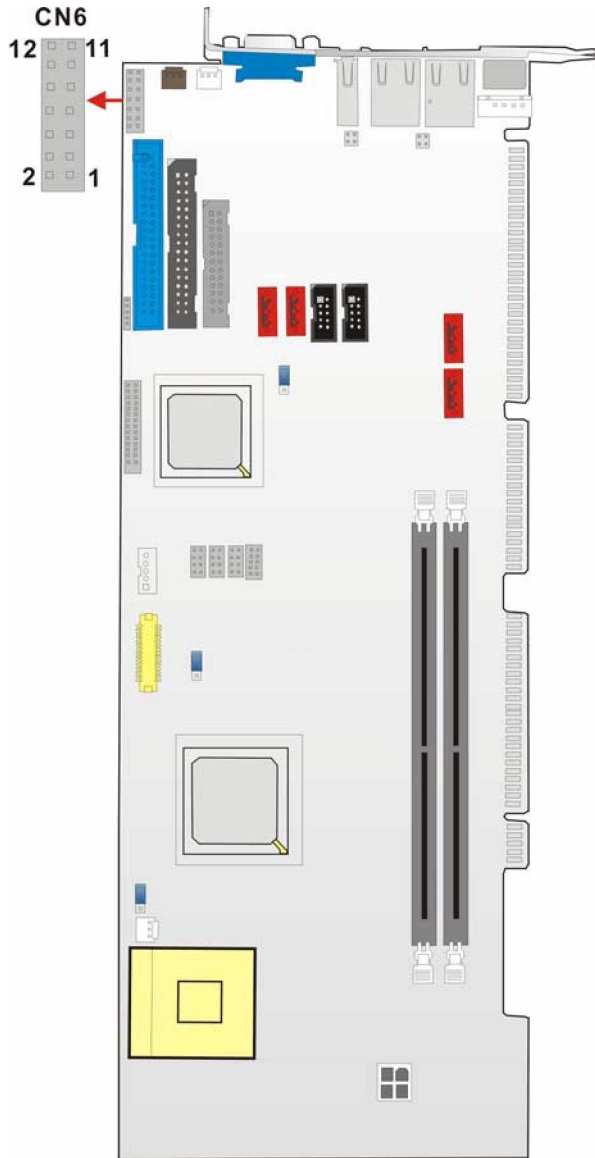

Figure 3-9: System Panel Connector Location

### 3.2.9 IrDA Connector

<b>CN Label:</b>	<b>J2</b>
<b>CN Type:</b>	<b>1x5 pin header</b>
<b>CN Location:</b>	<b>See Figure 3-10</b>
<b>CN Pinouts:</b>	<b>See Table 3-12</b>

The integrated IrDA connector supports both the SIR and ASKIR infrared protocols.

PIN	DESCRIPTION
1	VCC
2	NC
3	IR-RX
4	GND
5	IR-TX

Table 3-12: IrDA Connector Pinouts

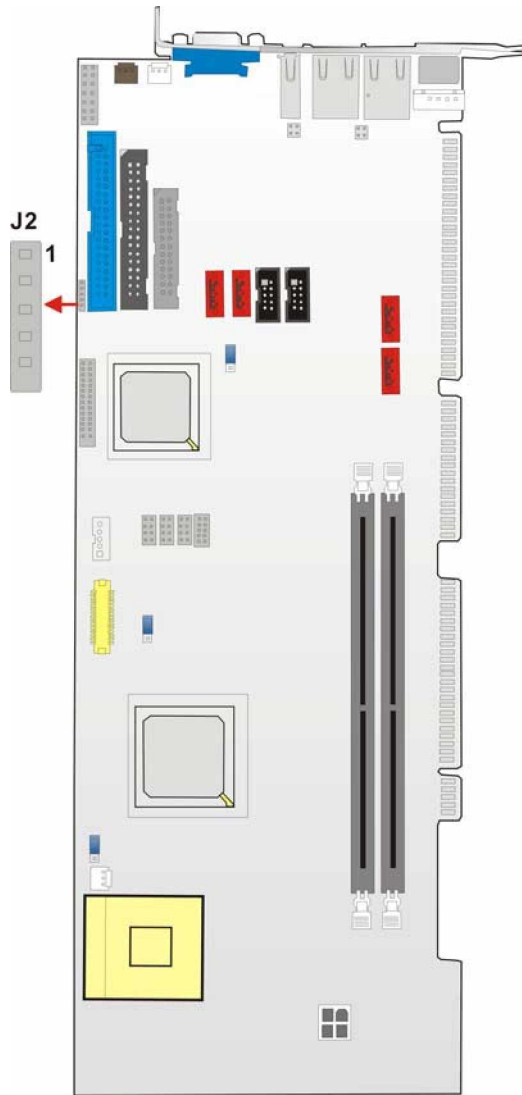

Figure 3-10: IrDA Connector Location

### 3.2.10 SATA Drive Connectors

**CN Label:** SATA1, SATA2, SATA3, SATA4

**CN Type:** 1x7 pin port

**CN Location:** See Figure 3-11

**CN Pinouts:** See Table 3-13

The SATA drive ports are connect to SATA HDDs with SATA signal cables.

- „ The SATA1 and SATA2 connectors provide connectivity with a maximum data transfer rate of 150MB/s and must be connected to first generation SATA-I drives.
- „ The SATA3 and SATA4 connectors provide connectivity with a maximum data transfer rate of 300MB/s and must be connected to second generation SATA-II drives. The SATA3 and SATA4 connectors are only found on the 3301650B and 3301650D.

PIN	DESCRIPTION	PIN	DESCRIPTION
1	GND	5	RX-
2	TX+	6	RX+
3	TX-	7	GND
4	GND		

**Table 3-13: SATA Connector Pinouts**



#### **CAUTION!**

Your SATA hard drives may come with both a 4P power connector and a SATA power interface. Attach either the 4P connector or the included SATA power cable to your SATA hard drives. **DO NOT** attach both the power connectors to your SATA hard drives at the same time! Doing so will cause damage.

---

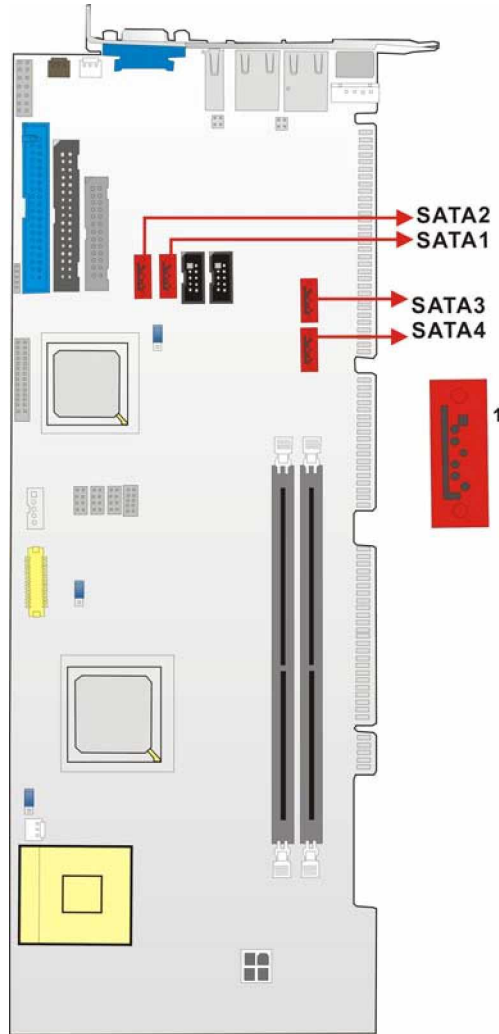

Figure 3-11: SATA Connector Locations



**NOTE:**

1. SATA is supported by:
    - Windows 2000 SP4
    - Windows XP SP1
    - Windows 2003, or later versions.
  2. Older OSes, such as Windows 98SE or ME, do not support the SATA interface.
-

### 3.2.11 DVI (Digital Visual Interface) Connector

- CN Label:** DVI1
- CN Type:** 2x13 pin header
- CN Location:** See Figure 3-12
- CN Pinouts:** See Table 3-14

The 3301650 CPU card provides a digital visual interface for digital display. Optional accessory IO-KIT-001 modules can be selected to connect to external DVI devices.

PIN NO.	DESCRIPTION	PIN NO.	DESCRIPTION
1	Data 2-	14	+5V Power
2	Data 2+	15	GND
3	GND	16	Hot Plug Detect.
4	N/C	17	Data 0-
5	N/C	18	Data 0+
6	DDC Clock	19	GND
7	DDC Data	20	N/C
8	N/C	21	N/C
9	Data 1-	22	GND
10	Data 1+	23	Clock +
11	GND	24	Clock -
12	N/C	25	GND
13	N/C		

**Table 3-14: DVI Connector Pinouts**

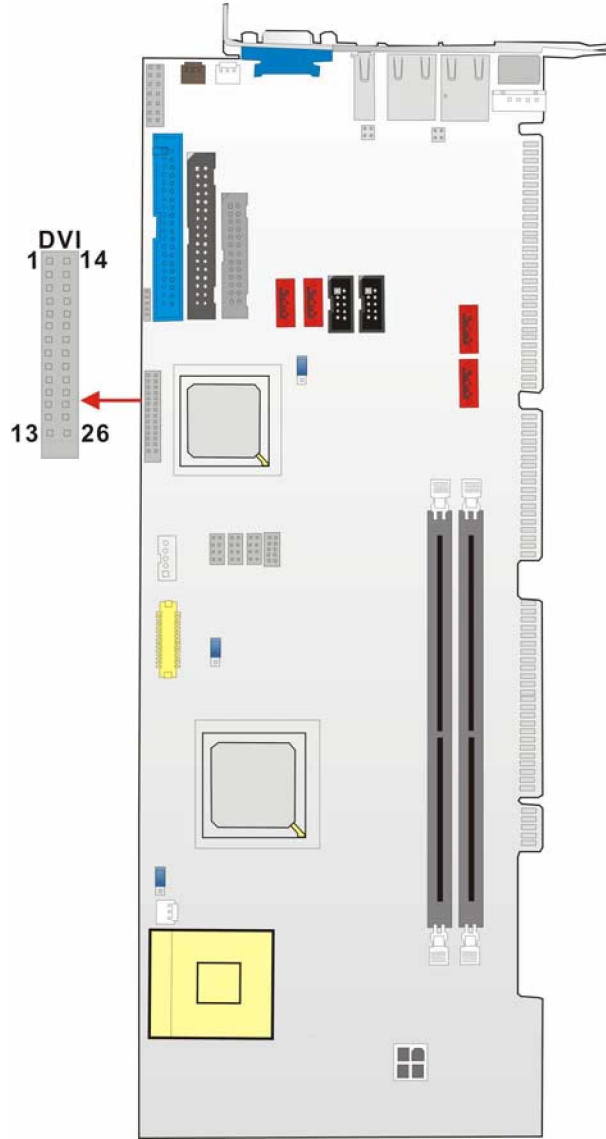

Figure 3-12: DVI1 Connector Location

### 3.2.12 LVDS Connector

<b>CN Label:</b>	<b>LVDS1</b>
<b>CN Type:</b>	<b>2x15 pin header</b>
<b>CN Location:</b>	<b>See Figure 3-13</b>
<b>CN Pinouts:</b>	<b>See Table 3-15</b>



The LVDS connector allows for an 18-bit, dual-channel, low noise, low power, and low amplitude high-speed data connection between the CPU card and LCD panel.

PIN	DESCRIPTION	PIN	DESCRIPTION
1	GND	2	GND
3	LVDS_Y0+	4	LVDS_Y0-
5	LVDS_Y1+	6	LVDS_Y1-
7	LVDS_Y2+	8	LVDS_Y2-
9	LVDS_CLK+	10	LVDS_CLK-
11	LVDS_Y3+	12	LVDS_Y3-
13	GND	14	GND
15	LVDSB_Y0+	16	LVDSB_Y0-
17	LVDSB_Y1+	18	LVDSB_Y1-
19	LVDSB_Y2+	20	LVDSB_Y2-
21	LVDSB_CLK+	22	LVDSB_CLK-
23	LVDSB_Y3+	24	LVDSB_Y3-
25	GND	26	GND
27	PVDD	28	PVDD
29	PVDD	30	PVDD

**Table 3-15: LVDS Connector Pinouts**

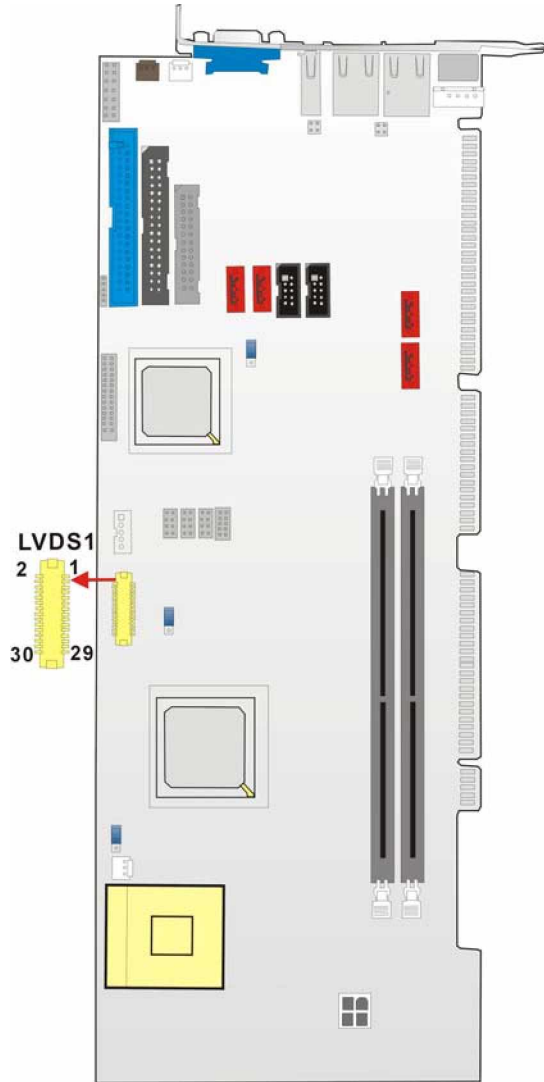

Figure 3-13: LVDS LCD Panel Connection Port

### 3.2.13 Inverter Control

<b>CN Label:</b>	<b>CN1</b>
<b>CN Type:</b>	<b>1x5 pin header</b>
<b>CN Location:</b>	<b>See Figure 3-14</b>
<b>CN Pinouts:</b>	<b>See Table 3-16</b>

The inverter control connector enables power on/off backlight during the power saving mode.

PIN	DESCRIPTION	PIN	DESCRIPTION
1	VCC+5V	2	GND
3	VCC+12V	4	GND
5	LCD_BKLEN		

**Table 3-16: Inverter Connector Pinouts**

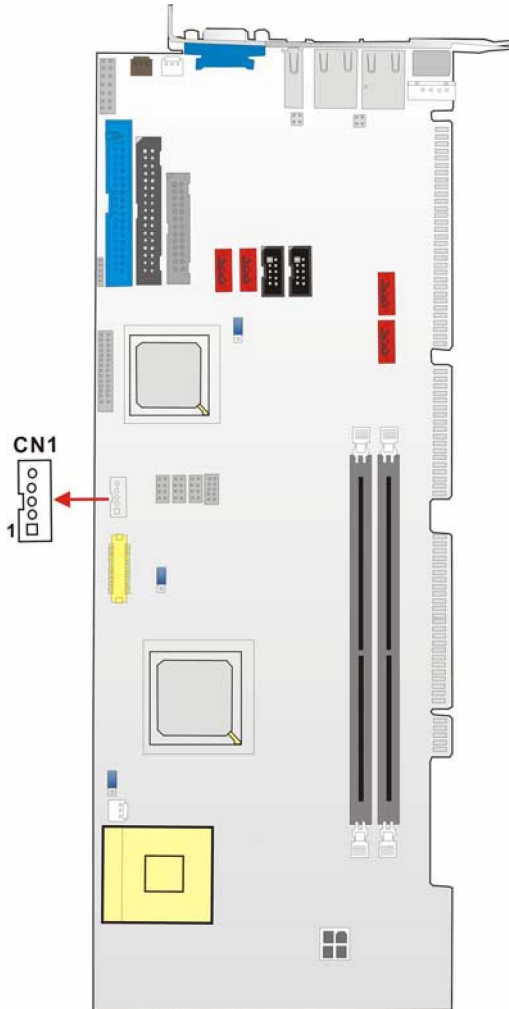

**Figure 3-14: J1 Inverter Control**

### 3.2.14 LAN State LED Connector

- CN Label:** CN4 and CN5
- CN Type:** 2x13 pin header
- CN Location:** See Figure 3-15

CN Pinouts: See Table 3-17

PIN NO.	DESCRIPTION
1	LED LINK 1000
2	LED LINK 10/100
3	LAN_LINK
4	ACT/LINK LED-Green

Table 3-17: J\_LANLED Connector Pinouts

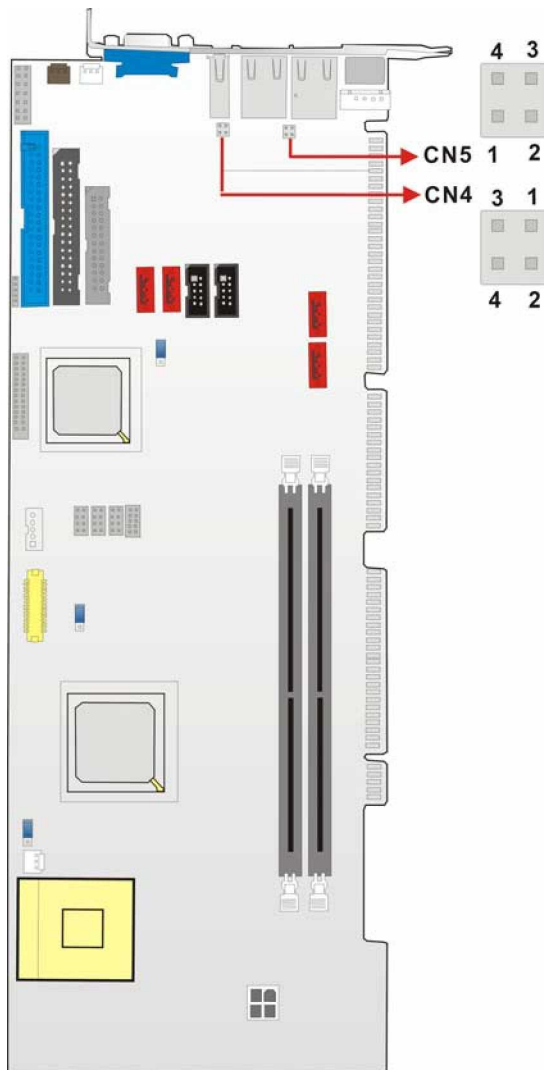

Figure 3-15: J\_LANLED Connector Locations

### 3.2.15 AC'97 Connector

- CN Label:** CN9
- CN Type:** 2x5 pin header
- CN Location:** See Figure 3-16
- CN Pinouts:** See Table 3-18

The 3301650 CPU card does not have a built-in AC'97 audio codec. If your system needs audio then this connector must be connected to an external audio codec module.

<b>PIN</b>	<b>DESCRIPTION</b>	<b>PIN</b>	<b>DESCRIPTION</b>
1	AC_SYNC	2	AC_BIT_CLK
3	AC_SDOUT	4	AC_PCBEEP
5	AC_SDIN2	6	AC_RST
7	+5V	8	GND
9	+12V	10	GND

**Table 3-18: CN9 Connector Pinouts**

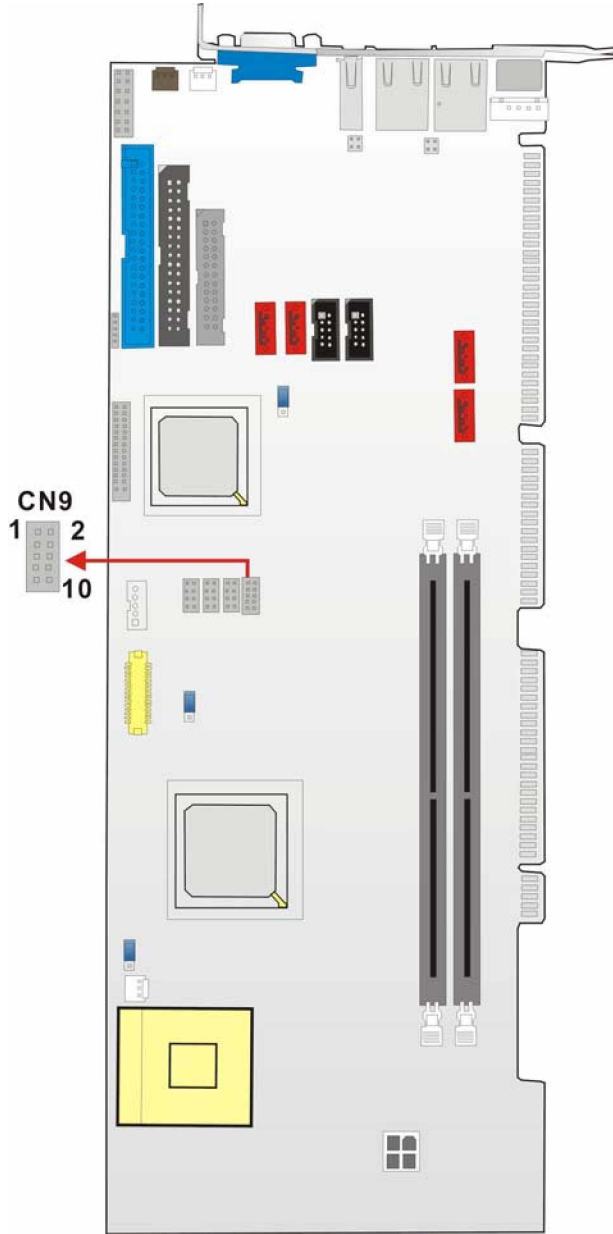

Figure 3-16: CN9 Connector Location

### 3.2.16 Keyboard Connector

- CN Label: KB1
- CN Type: 1x5 pin header
- CN Location: See Figure 3-17

**CN Pinouts:** See Table 3-19

For alternative application, a keyboard pin header connector is also available on board. This connector requires a special adapter cable.

PIN	DESCRIPTION
1	KEYBOARD CLOCK
2	KEYBOARD DATA
3	N/C
4	GND
5	VCC

**Table 3-19: KB1 Connector Pinouts**

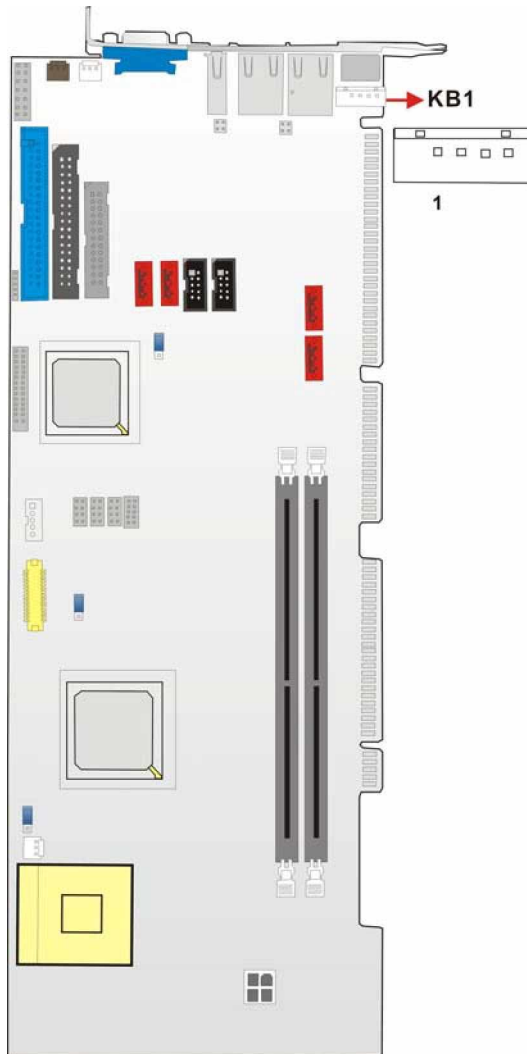

Figure 3-17: KB1 Connector Location

### 3.2.17 ATX-12V Power Source Connector

- CN Label:** CN100
- CN Type:** 2x2 pin header
- CN Location:** See Figure 3-18
- CN Pinouts:** See Table 3-20

This connector supports the ATX-12V power supply.

PIN NO.	DESCRIPTION	PIN NO.	DESCRIPTION
1	GND	3	+12V
2	GND	4	+12V

Table 3-20: CN100 Connector Pinouts

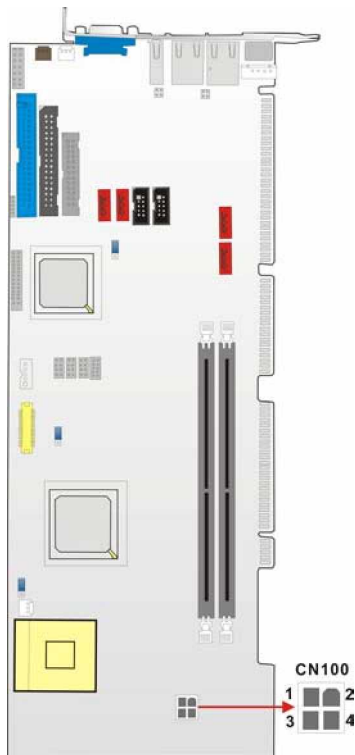

Figure 3-18: ATX Connector Location



### 3.3 External (Rear Panel) Connectors

**Figure 3-19** shows the 3301650 CPU card rear panel. The peripheral connectors on the back panel can be connected to devices externally when the CPU card is installed in a chassis. The peripheral connectors on the rear panel are:

- „ 1 x PS/2 keyboard connector
- „ 1 x USB connectors
- „ 2 x RJ-45 GbE connectors
- „ 1 x VGA connector

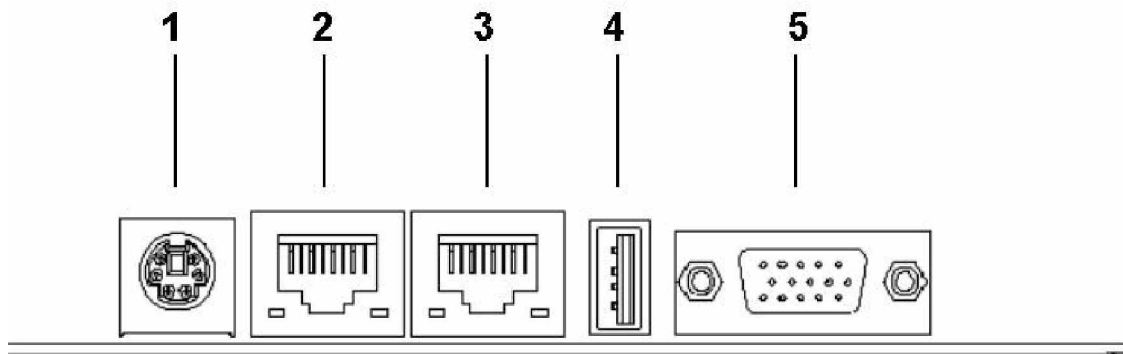

**Figure 3-19: 3301650 CPU card Rear Panel**

#### 3.3.1 PS/2 Connector

**CN Label:** KB/MS\_C1

**CN Type:** PS/2

**CN Location:** See Figure 3-19 (labeled number 1)

**CN Pinouts:** See Table 3-21

**Figure 3-20 shows PS/2 Pinout locations**

The PS/2 mouse and keyboard connectors are connected to a mouse and keyboard.

PIN	DESCRIPTION	PIN	
1	KB Data	2	N/C
3	GND	4	+5V
5	Clock	6	N/C

Table 3-21: PS/2 Pinouts

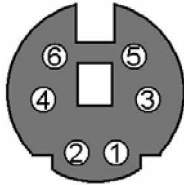

Figure 3-20: PS/2 Pinout locations

### 3.3.2 USB Connector

- CN Label:** USB\_C1
- CN Type:** USB port
- CN Location:** See Figure 3-19 (labeled number 4)
- CN Pinouts:** See Table 3-22

USB devices can be connected directly to the USB connectors on the rear panel.

PIN	DESCRIPTION	PIN	DESCRIPTION
1	+5V	2	DATA-
3	DATA+	4	GND

Table 3-22: USB Connectors

### 3.3.3 Ethernet Connectors

- CN Label:** LAN\_C1, LAN\_C2
- CN Type:** RJ-45
- CN Location:** See Figure 3-19 (labeled number 2 and number 3)
- CN Pinouts:** See Table 3-23

Two 1Gb connections can be made between the Ethernet connectors and a Local Area Network (LAN) through a network hub. An RJ-45 Ethernet connector is shown in **Figure 3-21**.

PIN	DESCRIPTION	PIN	DESCRIPTION
1	TXD+	8	GND
2	TXD-	9	GRN+
3	RXD+	10	GRN-
4	CT_TXD	11	YEL-
5	CT_RXD	12	YEL+
6	RXD-	13	S GND
7	N/C	14	S GND

**Table 3-23: RJ-45 Ethernet Connector Pinouts**

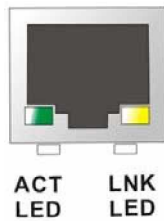

**Figure 3-21: RJ-45 Ethernet Connector**

The RJ-45 Ethernet connector has two status LEDs, one green and one yellow. The green LED indicates activity on the port and the yellow LED indicates the port is linked. See **Table 3-24**.

STATUS	DESCRIPTION	STATUS	
GREEN	Activity	YELLOW	Linked

**Table 3-24: RJ-45 Ethernet Connector LEDs**

### 3.3.4 VGA Connector

**CN Label:** CN2

**CN Type:** 15-pin

**CN Location:** See **Figure 3-19** (labeled number 7)

The standard 15-pin VGA connector connects to a CRT or LCD display monitor.

PIN	DESCRIPTION	PIN	DESCRIPTION
1	Red	9	No Connect
2	Green	10	Ground
3	Blue	11	No Connect
4	No Connect	12	DDC DAT
5	Ground	13	Horizontal Synchronization
6	Ground	14	Vertical Synchronization
7	Ground	15	DDC Clock
8	Ground		

Table 3-25: VGA Connector Pinouts

### 3.4 Onboard Jumpers



**NOTE:**

A jumper is a metal bridge that is used to close an electrical circuit. It consists of two metal pins and a small metal clip (often protected by a plastic cover) that slides over the pins to connect them. To CLOSE/SHORT a jumper means connecting the pins of the jumper with the plastic clip and to OPEN a jumper means removing the plastic clip from a jumper.

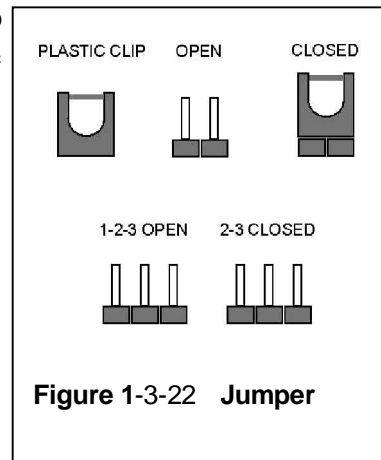

Figure 1-3-22 Jumper

The 3301650 CPU card has three onboard jumpers. The jumpers are described in Table 3-26.

Label	Purpose		pe
JP1	Panel Voltage Selection	Allows a user to select the front panel voltage	3-pin
JP2	Reset CMOS	Resets the CMOS	3-pin
JP3	FSB Speed	Allows users to specify the FSB speed	3-pin

Table 3-26: Jumpers

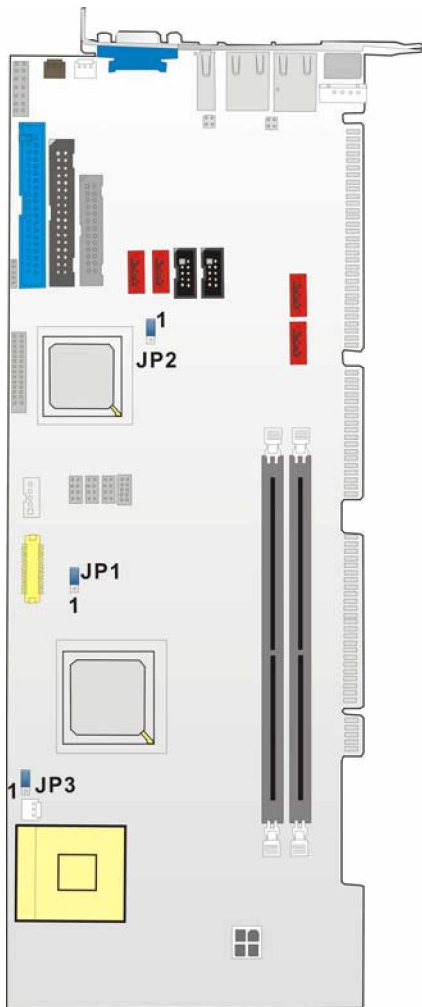

Figure 3-23: Jumper Locations

### 3.4.1 LVDS Panel Voltage Selection Jumper

<b>Jumper Label:</b>	<b>JP1</b>
<b>Jumper Type:</b>	<b>3 pin header</b>
<b>Jumper Settings:</b>	<b>See Table 3-27</b>
<b>Jumper Location:</b>	<b>See Figure 3-23</b>

This jumper allows the user to set the voltage for the LVDS panel. Before setting this jumper please refer to your LCD panel user guide to determine the required voltage. After you have determined the required voltage, make the necessary jumper setting in accordance with the settings shown in **Table 3-27**.



#### **WARNING:**

Selecting the wrong voltage will burn the LCD. Please check LCD technical documents provided by the vendor for the correct voltage.

---

<b>JP1</b>	<b>LVDS Voltage Select</b>
1-2 closed	3.3V (default)
2-3 closed	5V

**Table 3-27: JP1 Jumper Settings**

### 3.4.2 Reset CMOS Jumper

<b>Jumper Label:</b>	<b>JP2</b>
<b>Jumper Type:</b>	<b>3 pin header</b>
<b>Jumper Settings:</b>	<b>See Table 3-28</b>
<b>Jumper Location:</b>	<b>See Figure 3-23</b>

If the CPU Card fails to boot due to improper BIOS settings, use this jumper to clear the CMOS data and reset the system BIOS information. To do this, use the jumper cap to close pins 2 and 3 for a few seconds then reinstall the jumper clip back to pins 1 and 2.

If the “CMOS Settings Wrong” message displays during the boot up process, you may then try to correct the fault by pressing the F1 to enter the CMOS Setup menu. You may then do one of the following:

- „ Enter the correct CMOS setting
- „ Load Optimal Defaults
- „ Load Failsafe Defaults.

After you have done one of the above, save your changes and exit the CMOS Setup menu.

<b>JP2</b>	<b>CLEAR CMOS</b>
1-2 closed	Normal (default)
2-3 closed	Clear CMOS

**Table 3-28: JP2 Jumper Settings**

### 3.4.3 FSB Selection Jumper

- Jumper Label:** JP3
- Jumper Type:** 3 pin header
- Jumper Settings:** See Table 3-29
- Jumper Location:** See Figure 3-23

This jumper allows the user to set the FSB speed. Refer to the CPU technical documents that came with the CPU you wish to install on the 3301650. After determining the FSB of the CPU, change the jumper settings in accordance with the settings shown in **Table 3-29**.

## 3301650 CPU Card

<b>JP1</b>	<b>CPU FSB Select</b>
1-2 closed	400MHz
2-3 closed	533MHz (default)

**Table 3-29: JP3 Jumper Settings**



Chapter

4

# 4 Installation and Configuration

---

## 4.1 Installation Considerations

---



### NOTE:

The following installation notices and installation considerations should be read and understood before the CPU card is installed. All installation notices pertaining to the installation of the CPU card should be strictly adhered to. Failing to adhere to these precautions may lead to severe damage of the CPU card and injury to the person installing the CPU card.

---

### 4.1.1 Installation Notices

Before and during the installation of the 3301650 CPU card, please **do** the following:

- „ Read the user manual  
The user manual provides a complete description of the 3301650 CPU card, installation instructions and configuration options.
- „ Wear an electrostatic discharge cuff (ESD)  
Electronic components are easily damaged by ESD. Wearing an ESD cuff will remove ESD from your body and help to prevent ESD damage to the CPU card.
- „ Place the CPU Card on an antistatic pad  
When you are installing or configuring the CPU Card, place it on an antistatic pad. This will help to prevent potential ESD damage.
- „ Turn off all power to the 3301650 CPU card  
When working with the CPU card, make sure that it is disconnected from all power supplies and that no electricity is being fed into the system.

Before and during the installation of the 3301650 CPU card **DO NOT:**

- „ remove any of the stickers on the PCB board. These stickers are required for warranty validation.

- „ use the product before you have verified that all cables and power connectors are properly connected.
- „ allow screws to come in contact with the PCB circuit, connector pins, or its components.

## 4.2 Unpacking

---



### NOTE:

If any of the items listed below are missing when you unpack the 3301650 CPU card, do not proceed with the installation and contact the reseller or vendor you purchased the CPU card from.

---

### 4.2.1 Unpacking Precautions

Before you install the 3301650 CPU card, you must unpack the CPU card. Some components on 3301650 are very sensitive to static electricity and can be damaged by a sudden rush of power. To protect it from being damage, follow these precautions:

- „ Ground yourself to remove any static charge before touching your 3301650 . You can do so by wearing a grounded wrist strap at all times or by frequently touching any conducting materials that is connected to the ground.
- „ Handle your 3301650 by its edges. Do not touch the IC chips, leads or circuitry if not necessary.

Do not place a PCB on top of an anti-static bag. Only the inside of the bag is safe from static discharge.

### 4.2.2 Checklist

When you unpack the 3301650 , please make sure that your package contains the following items.

- „ 1 x 3301650 single board computer
- „ 1 x mini jumper pack
- „ 1 x ATA 66/100 flat cable

## 3301650 CPU Card

- „ 2 x SATA cables
- „ 1 x SATA power cable
- „ 4 x SATA-II cables
- „ 2 x SATA-II power cables
- „ 1 x Keyboard/ PS2 mouse Y cable
- „ 1 X RS-232 cable
- „ 1 x ATX-12V cable
- „ 1 x USB cable
- „ 1 x Utility CD
- „ 1 x QIG

If one or more of these items are missing, please contact the reseller or vendor you purchased the 3301650 CPU card from and do not proceed any further with the installation.

### 4.3 3301650 CPU Card Installation

---



#### **WARNING!**

1. Never run the CPU card without an appropriate heatsink and cooler that can be ordered from GAI or purchased separately.
  2. Be sure to use the CPU 12V power connector (CN10007) for the CPU power.
- 



#### **WARNING!**

Please note that the installation instructions described in this manual must be carefully followed in order to avoid damage to the CPU card components and injury to you.

---



### **WARNING!**

When installing electronic components onto the CPU card always follow the previously outlined anti-static precautions in order to prevent ESD damage to your board and other electronic components like the CPU and DIMM modules

---

The following components must be installed onto the CPU card or connected to the CPU Card during the installation process.

- „ CPU
- „ CPU cooling kit
- „ DIMM modules
- „ Peripheral device connection

### **4.3.1 CPU Installation**



### **WARNING!**

CPUs are expensive and sensitive components. When you install the CPU please be careful not to damage it in anyway. Make sure you install it properly and ensure that a heatsink and CPU cooling fan is properly installed before you run the CPU card or else both the CPU and the board will be damaged.

---

To install an Intel 479-pin CPU onto your motherboard, follow the steps below:

**Step 1: Is the CPU retention screw in an unlocked position?** When shipped, the retention screw of the CPU socket should be in the unlocked position. If it is not in the unlocked position, use a screwdriver to position it in an unlocked position.

(See **Figure 4-1**)

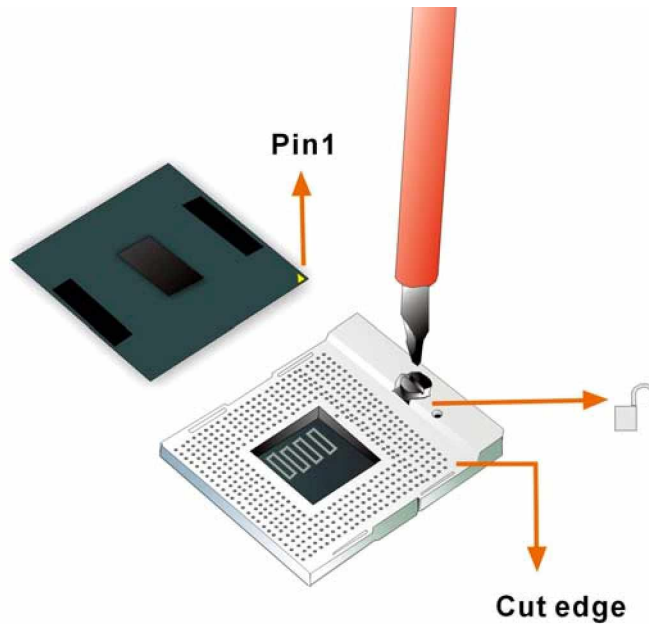

**Figure 4-1: Make sure the CPU socket retention screw is unlocked**

**Step 2: Inspect the CPU socket.** Make sure there are no bent pins and make sure the socket contacts are free of foreign material. If any debris is found, remove it with compressed air.

**Step 3: Correctly position the CPU.** Make sure the pin 1 mark matches the cut edge on the CPU socket. Carefully place the CPU on top of the socket. When properly placed, the CPU should be easily inserted into the socket.

**Step 4: Insert the CPU.** To insert the CPU into the socket, hold the CPU by its edges and follow the instructions below:

- a. Correctly orientate the CPU with the IHS (Integrated Heat Sink) side facing upward.
- b. Locate the pin 1 mark on the CPU.
- c. Gently insert the CPU into the socket.
- d. Rotate the retention screw into the locked position. (See **Figure 4-2**) Step 0:

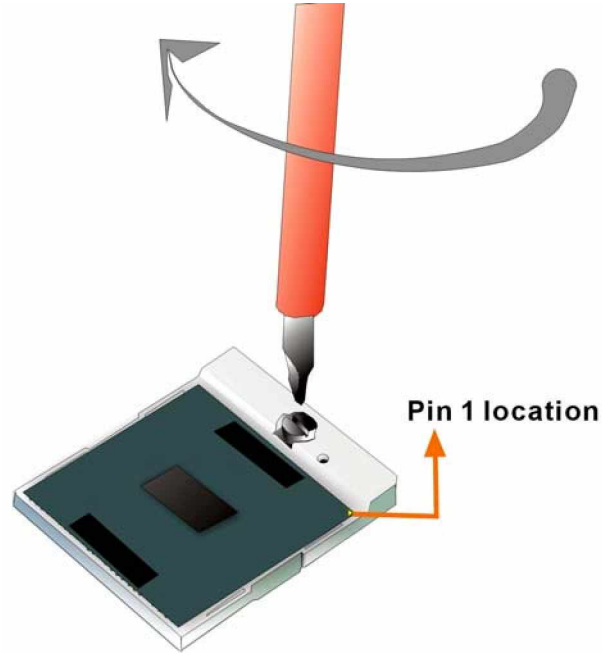

Figure 4-2: Lock the CPU Socket Retention Screw

#### 4.3.2 Cooling Kit (CF-518-RS) Installation



Figure 4-3: Cooling Kit

GAI provides a cooling kit designed for socket 479 CPUs. (See **Figure 4-3**)  
The cooling kit is comprised of a CPU heatsink and a cooling fan.

**NOTE:**

The CF-518-RS heatsink comes with a sprayed layer of thermal paste. Make sure you do not accidentally wipe away the thermal paste while unpacking or installing the heatsink. Thermal paste between the CPU and the heatsink is important for optimum heat dissipation.

To install the CF-518 cooling kit, please follow the steps below.

- Step 1: Place the cooling kit onto the CPU.** Make sure that the CPU cable can be properly routed when the cooling kit is installed.
- Step 2: Properly align the cooling kit.** Make sure its four threaded screw fasteners can pass through the pre-drilled holes on PCB.
- Step 3: Secure the cooling kit.** From the solder side of the PCB, align the provided nut caps to the heatsink screw threads that protrude through the PCB holes. Without over tightening the nut caps, insert them onto the protruding screw threads to secure the cooling kit to the PCB board. (See **Figure 4-4**)

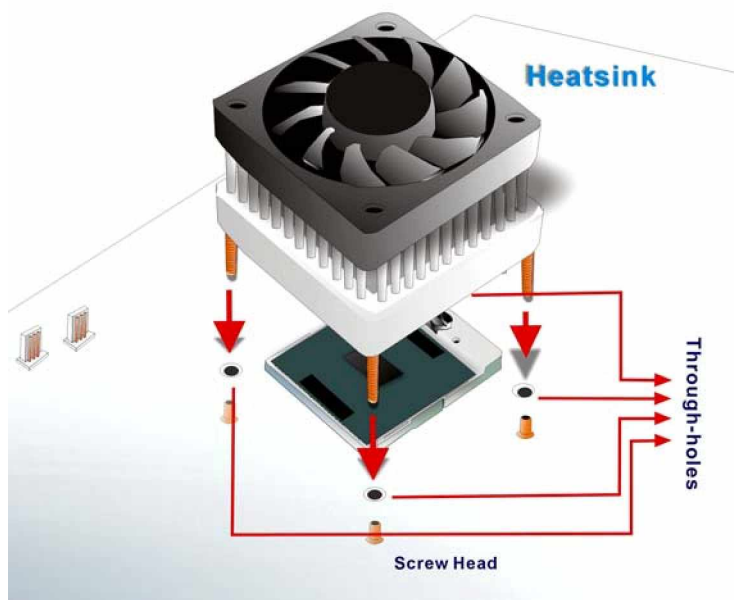
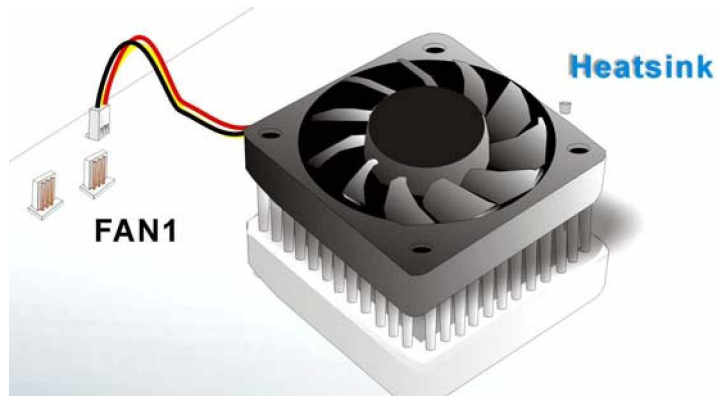

**Figure 4-4: Securing the Cooling Kit**

- Step 4: Connect the fan cable.** Connect the cooling kit fan cable to the FAN2 connector



on the CPU card. Carefully route the cable and avoid heat generating chips and fan blades. (See **Figure 4-5**) Step 0:



**Figure 4-5: Connect the cooling fan cable**

### 4.3.3 DIMM Module Installation

#### 4.3.3.1 Purchasing the Memory Module



#### **WARNING!**

The DDR2 architecture is not compatible with DDR1 modules. If your system is installed with DDR1 modules, damage might occur and you will not be able to boot up your system.

When you purchase your DIMM modules, the following considerations should be taken into account:

- „ Each DIMM socket can support DIMM modules with a maximum size of 1GB
- „ Only use DDR2 memory chips in the DIMM slots
- „ It is recommended that you use memory modules of identical brand, size, chips, and speed.
- „ DIMMs must use the same density memory chips
- „ Both DIMMs must use the same DRAM bus width
- „ Both DIMMs must be either single-sided or dual-sided.

### 4.3.3.2 DIMM Module Installation

The 3301650 CPU card has two DDR SDRAM DIMM sockets. To install the DIMM modules, follow the instructions below.

**Step 1:** Pull the two white handles on either side of the DIMM socket down.

**Step 2:** Align the DIMM module with the DIMM socket making sure the matching pins are correctly aligned.

**Step 3:** Insert the DIMM module slowly. Once you are sure it is correctly inserted, push down firmly. The white handles on either side of the socket will move back up and lock the module into the socket. Step 0:

### 4.3.4 Peripheral Device Connection

Cables provided by GAI that connect peripheral devices to the CPU Card are listed in

**Table 4-1.** Cables not included in the kit must be separately purchased.

Quantity	pe
1	ATA 66/100 flat cable
2/4	SATA cables (SATA-II channel models have 4)
1/2	SATA power cable (SATA-II channel models have 2)
1	Keyboard/ PS2 mouse Y cable
1	ATX-12V cable
1	RS-232 cable
1	USB cable
1	LPT cable (optional)
1	FDD cable (optional)
1	DVI cable (optional)

**Table 4-1: GAI Provided Cables**

#### 4.3.4.1 IDE Disk Drive Connector (IDE1)

The cable used to connect the CPU card to the IDE HDD is a standard 44-pin ATA 66/100 flat cable. To connect an IDE HDD to the CPU Card, follow the instructions below.

- Step 1:** Find the ATA 66/100 flat cable in the kit that came with the CPU Card.
- Step 2:** Connect one end of the cable to the IDE1 connector on the CPU card. A keyed pin on the IDE connector prevents it from being connected incorrectly.
- Step 3:** Locate the red wire on the other side of the cable that corresponds to the pin 1 connector.
- Step 4:** Connect the other side of the cable to the HDD making sure that the pin 1 cable corresponds to pin 1 on the connector.



### NOTE:

When two EIDE disk drives are connected together, back-end jumpers on the drives must be used to configure one drive as a master and the other as a slave.

---

#### 4.3.4.2 Floppy Drive Connector (FDD1)

This connector provides access to two externally mounted 3.5" floppy drives. To connect the CPU Card to a FDD, follow the instructions below.

- Step 1:** Insert one side of the cable into the FDC making sure that the red wire on the cable corresponds to pin 1 on the connector.
- Step 2:** Attach the connector on the other side of the cable to the floppy drive(s). You can only use one connector in the set. The connection sequence determines which of the two connected floppy drives is drive A: and which is drive B. Step 0:

### 4.4 Jumper Configuration

The 3301650 CPU card has three onboard jumpers. They are,

- „ Panel Voltage Selection
- „ Reset CMOS

„ FSB Speed

Before the 3301650 CPU card is installed into a chassis, make sure the jumper settings are properly configured. For more information about jumper settings and configurations, please refer to **Section 3.4: Onboard Jumpers** above.

### 4.5 Chassis Installation

After the CPU, the cooling kit, and the DIMM modules have been installed and after the internal peripheral connectors have been connected to the peripheral devices and the jumpers have been configured, the CPU Card can be mounted into a chassis.

To mount the CPU Card into a chassis please refer to the chassis user guide that came with the product.

### 4.6 Rear Panel Connectors

#### 4.6.1 LCD Panel Connection

The conventional CRT monitor connector, VGA1, is a 15-pin, female D-SUB connector. Pin assignments can be seen in that can be connected to external monitors.

#### 4.6.2 Ethernet Connection

The rear panel RJ-45 connectors can be connected to an external LAN and communicate with data transfer rates up to 1Gb/s.

#### 4.6.3 USB Connection

The rear panel USB connector provides easier and quicker access to external USB devices. The rear panel USB connector is a standard connector and can easily be connected to other USB devices.

Chapter

5

# 5 Award BIOS Setup

---

## 5.1 Introduction

A licensed copy of Phoenix Award BIOS is preprogrammed into the ROM BIOS. The BIOS setup program allows users to modify the basic system configuration. This chapter describes how to access the BIOS setup program and the configuration options you may change.

### 5.1.1 Starting Setup

The Phoenix Award BIOS is activated when you turn on the computer. The setup program can be activated in one of two ways.

1. Press the **DELETE** key as soon as the system is turned on or
2. Press the **DELETE** key when the “**Press Del to enter SETUP**” message appears on the screen.

If the message disappears before you respond, you must restart your computer and try again.

### 5.1.2 Using Setup

Use the arrow keys to highlight items, press **ENTER** to select, use the PageUp and PageDown keys to change entries, press **F1** for help and press **Esc** to quit. Navigation keys are shown in.

Key	Function
Up arrow	Move to the item above
Down arrow	Move to the item below
Left arrow	Move to the item on the left hand side
Right arrow	Move to the item on the right hand side
+ / Page up	Increase the numeric value or make changes
- / Page down	Decrease the numeric value or make changes
Esc	Main Menu – Quit and not save changes into CMOS Status Page Setup Menu and Option Page Setup Menu -- Exit current page and return to Main Menu

F1	General help, only for Status Page Setup Menu and Option Page Setup Menu
F2	Item help
F5	Previous values for the page menu items
F6	Fail-safe defaults for the current page menu items
F7	Optimized defaults for the current page menu items
F9	Menu in BIOS
F10	Save changes and Exit BIOS

**Table 5-1: BIOS Navigation Keys**

### 5.1.3 Getting Help

When you press **F1** a small help window describing the appropriate keys to use and the possible selections for the highlighted item appears. To exit the Help Window press **Esc** or the **F1** key again.

### 5.1.4 Unable to Reboot After Configuration Changes

If you are unable to boot your computer after you have made changes to the system configuration, you must restore the CMOS defaults. Use the jumper described in **Chapter 3, Section 3.4.1**.

### 5.1.5 Main BIOS Menu

Once the BIOS opens, the main menu in **BIOS Menu 1** appears.

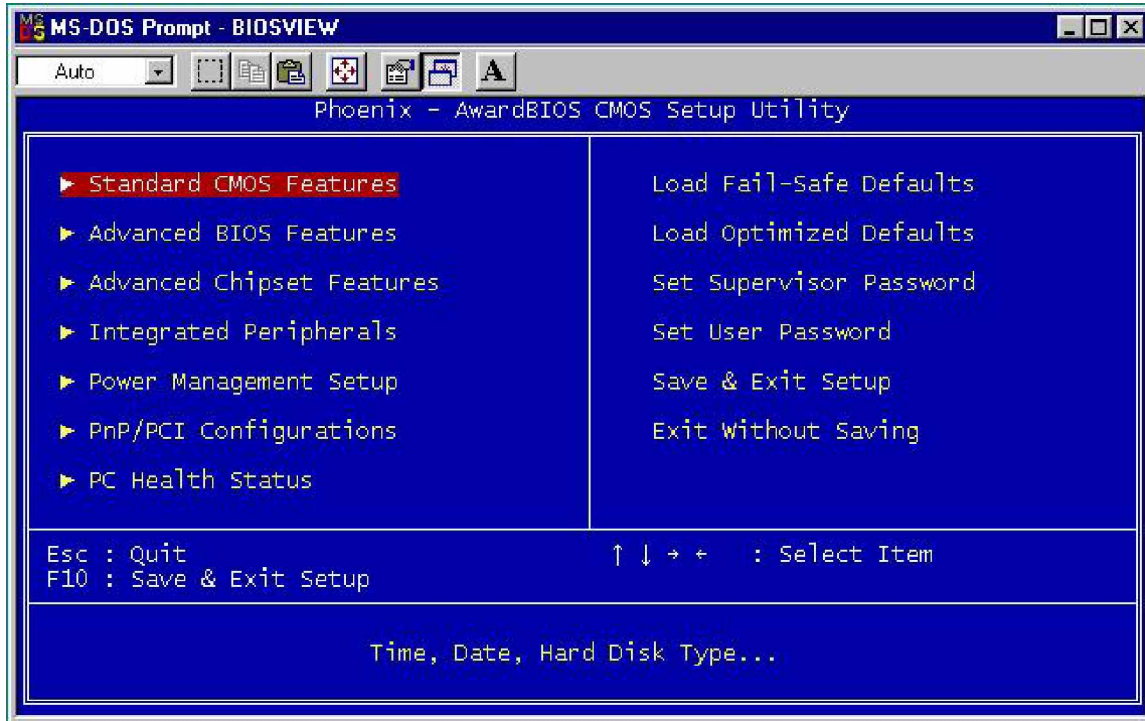

**BIOS Menu 1: Award BIOS CMOS Setup Utility**



**NOTE:**

The following sections will completely describe the menus listed below and the configuration options available to users.

The following menu options are seen in **BIOS Menu 1**.

- „ **Standard CMOS Features:** Changes the basic system configuration.
- „ **Advanced BIOS Features:** Changes the advanced system settings.
- „ **Advanced Chipset Features:** Changes the chipset configuration features
- „ **Integrated Peripherals:** Changes the settings for integrated peripherals
- „ **Power Management Setup:** Allows you to configure power saving options
- „ **PCIPnP:** Changes the advanced PCI/PnP Settings
- „ **PC Health Status:** Menu that monitors essential system parameters



The following user configurable options are also available in the BIOS Main Menu

### **Load Fail-Safe Defaults**

This option allows you to load failsafe default values for each of the parameters on the Setup menus. **F6 key can be used for this operation on any page.**

### **Load Optimized Defaults**

This option allows you to load optimal default values for each of the parameters on the Setup menus. **F7 key can be used for this operation on any page.**

### **Set Supervisor Password**

By default no **Supervisor Password** is set. If you wish to install a supervisor password, select this field and enter the password. After this option has been selected, a red dialogue box with “**Enter Password:** ” will appear. You will be asked to confirm your password. Retype the original password into the “**Confirm Password:** ” dialogue box and press enter.

### **Change User Password**

By default no **User Password** is set. If you wish to install a user password, select this field and enter the password. After this option has been selected, A red dialogue box with “**Enter Password:** ” will appear. You will be asked to confirm your password. Retype the original password into the “**Confirm Password:** ” dialogue box and press enter.

### **Save & Exit Setup**

If you have finished making the configuration changes and wish to save them and exit the BIOS menus, select this option.

### **Exit Without Saving**

If you have finished making configuration changes but do not want to save them and you want to exit the BIOS menus, select this option.

## 5.2 Standard CMOS Features

When you enter the **Standard CMOS Features** BIOS menu **BIOS Menu 2** appears. The **Standard CMOS Features** menu allows you to set basic BIOS configuration options.

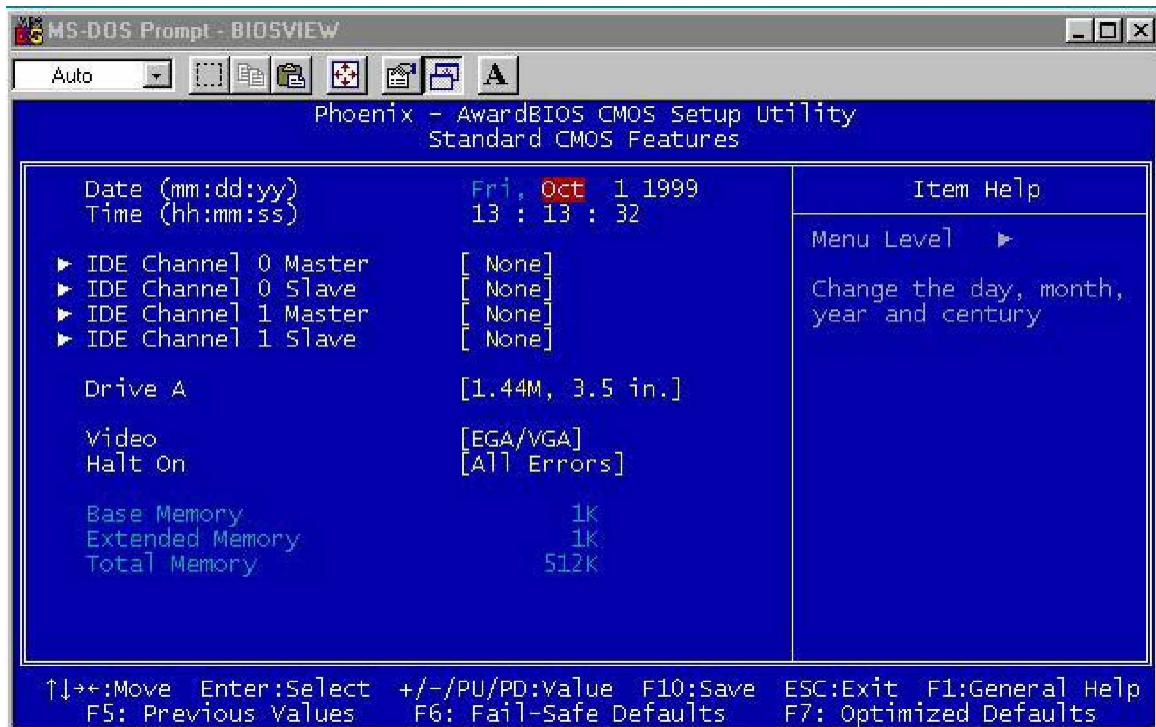

### BIOS Menu 2: Standard CMOS Features

The **Standard CMOS Features** menu allows you to set both the date and the time field:

- „ **Date [mm:dd:yy]**: Allows you to set the system date.
- „ **Time [Day hh/mm/ss]**: Allows you to set the system time.

#### IDE Master and IDE Slave

When entering setup, BIOS auto detects the presence of IDE devices. This displays the status of the auto detected IDE devices. The following IDE devices will be detected and are shown in the **Standard CMOS Features** menu:

- „ Primary IDE Master
- „ Primary IDE Slave
- „ Secondary IDE Master

„ Secondary IDE Slave

The IDE Configuration menu (**BIOS Menu 3**) allows you to set or change the configurations for the IDE devices installed in the system. If an IDE device is detected, and one of the above listed four BIOS configuration options are selected, the IDE configuration options shown in **Section 5.2.1** appear.

### **Drive A [1.44M, 3.5in]**

The **Drive A** configuration option determines the type of floppy drive installed in the system. The floppy drive configuration options are listed below.

„ None  
 „ 360K, 5.25 in  
 „ 1.2M, 5.25 in  
 „ 720K, 3.5 in  
 „ 1.44M, 3.5 in (DEFAULT)  
 „ 2.88M, 3.5in

### **Video [EGA/VGA]**

The **Video** configuration option allows users to select the adapter for the primary system monitor. Although secondary monitors are supported, you do not have to select the type in the BIOS setup. Video configuration options are listed below.

 **EGA/VGA** (DEFAULT) Selected when the adapter for the primary system monitor is one of the following:



 **EGA**

 **VGA**

 **SEGA**





 **SVGA**

 **PGA**

-  **CGA 40**                      The system will power up in 40 column mode
-  **CGA 80**                      The system will power up in 80 column mode
-  **MONO**                         A monochrome monitor is used. High-resolution monochrome monitors are also supported.

### **Halt On**

The **Halt On** category allows users to determine whether the computer will stop if an error is detected during power up.

-  **All Errors**                      (DEFAULT) Whenever BIOS detects a non-fatal error the system will be stopped and you will be prompted.
-  **No Errors**                      The system boot will not be stopped for any errors that may be detected
-  **All, But Keyboard**                      The system boot will not stop for a keyboard error; it will stop for all other errors.
-  **All, But Diskette**                      The system boot will not stop for a disk error; it will stop for all other errors.
-  **All, But Disk/Key**                      The system boot will not stop for a keyboard or a disk error; it will stop for all other errors.

### **Base Memory:**

The **Base Memory** is NOT user configurable. The POST will determine the amount of base (or conventional) memory is installed in the system. The value of the base memory is typically 512K for systems with 512K memory installed on the CPU card or 640K for systems with 640K or more memory installed on the motherboard.

## ↑ Extended Memory

The **Extended Memory** is NOT user configurable. The BIOS determines how much extended memory is present during the POST. This is the amount of memory above 1MB located in the memory address map of the CPU.

## ↑ Total Memory

The **Total Memory** is NOT user configurable.

### 5.2.1 IDE Channel Master

The **IDE Channel Master** menu (**BIOS Menu 3**) allows you to set or change the configurations for the master and slave IDE devices for both channel 0 and channel 1.

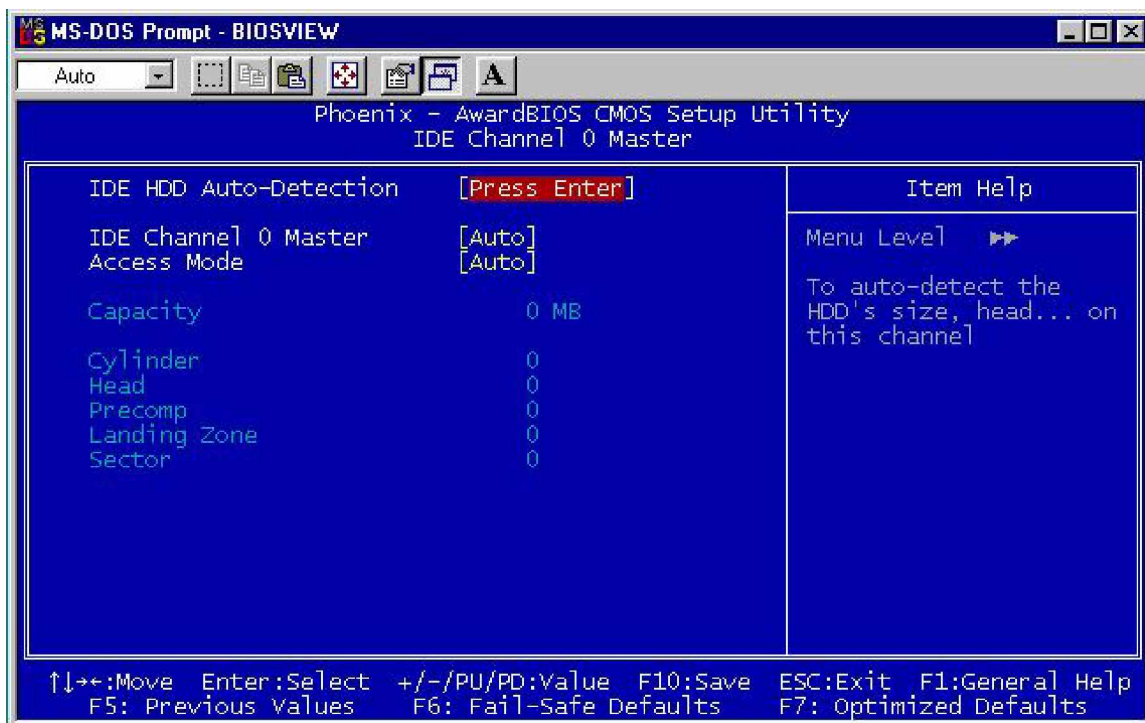

#### BIOS Menu 3: IDE Channel Master

## ↑ IDE HDD Auto-Detection [Press Enter]

Selecting **IDE HDD Auto-Detection** option and pressing the “**ENTER**” key will enable the BIOS to automatically detect the HDD type. Do not set this option manually.

### ↑ IDE Channel 0/1 Master/Slave [Auto]

The **IDE Channel** option allows you to activate or deactivate the following drive channels:

- „ Channel 0 Master
- „ Channel 0 Slave
- „ Channel 1 Master
- „ Channel 0 Slave

↑ **None** If you have no drives connected to the IDE channel select this option. Once set, this IDE channel will become inaccessible and any drives attached to it undetected.

↑ **Auto** (DEFAULT) Setting this option allows the device to be automatically detected by the BIOS

↑ **Manual** Selecting this option allows you to manually configure the device on the IDE channel in BIOS.

### ↑ Access Mode [Auto]

The **Access Mode** option allows you to determine the hard disk BIOS translation modes. Most systems now use hard drives with large capacities and therefore either the LBA translation mode or auto should be selected.

↑ **CHS** Select this mode if the HDD capacity is less than 504MB.

↑ **LBA** Select this mode if the HDD capacity is more than 8.4GB.

↑ **Large** This mode is an extended ECHS mode and while it supports HDDs larger than 504MB, it is not recommended.

↑ **Auto** (DEFAULT) If you are unsure of what access mode to set, select this

option

## **Capacity**

The **Capacity** specification tells the user the storage capacity of the HDD installed in the system.

## **Cylinder**

The **Cylinder** specification tells the user how many cylinders (tracks) are on the HDD installed in the system.

## **Head**

The **Head** specification tells the user how many logical heads are on the HDD installed in the system.

## **Precomp**

The **Precomp** specification tells the user on what track the write precompensation begins.

## **Landing Zone**

The **Landing Zone** specification tells the user where the disk head will park itself after the system powers off.

## **Sector**

The **Sector** specification tells the user how many logical sectors the HDD has been divided into.

## **5.3 Advanced BIOS Features**

The **Advanced BIOS Features** menu (**BIOS Menu 4**) allows you to access CPU and peripheral device configuration options.

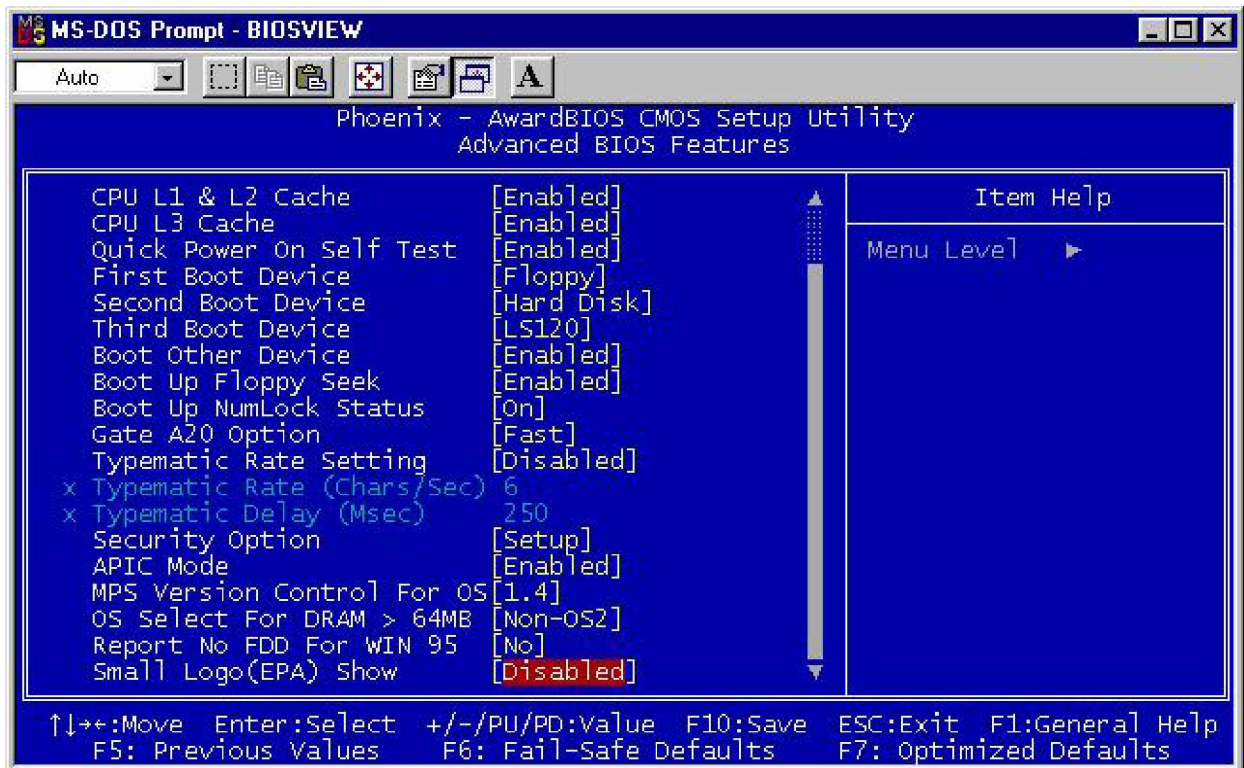
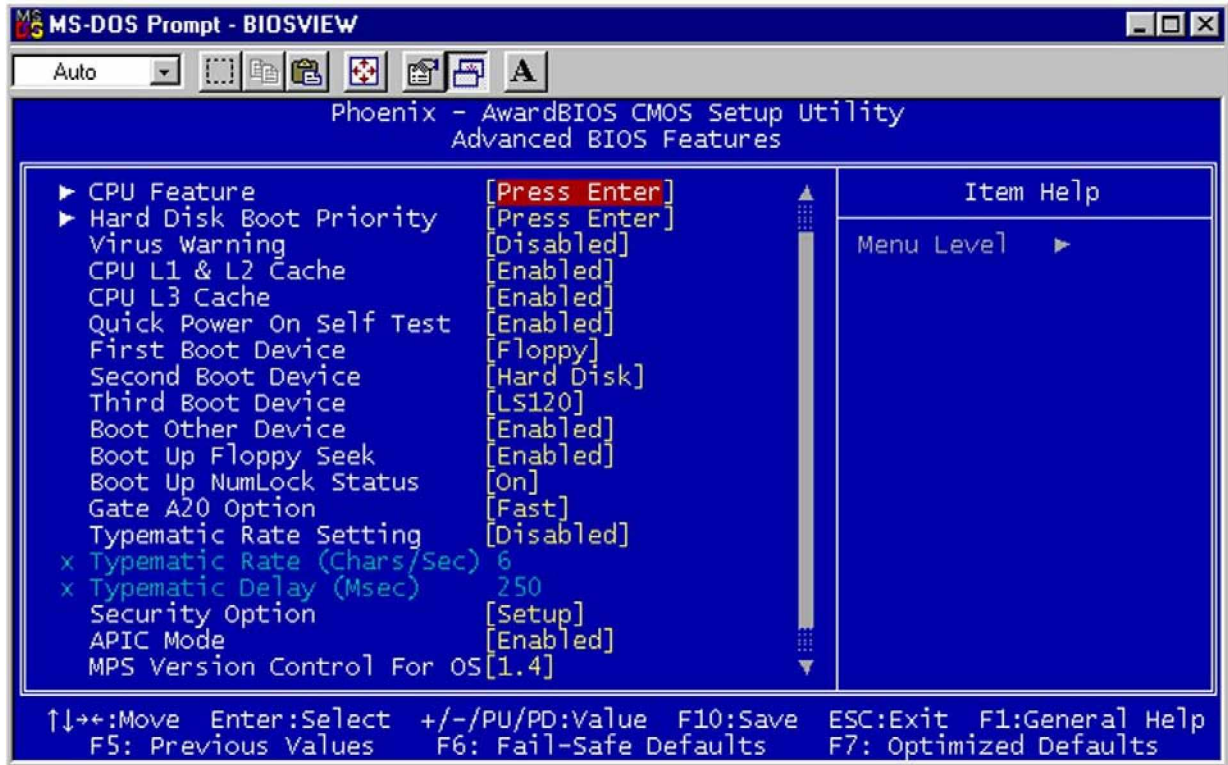

BIOS Menu 4: Advanced BIOS Features





Once the **Advanced BIOS Features** menu is selected, two menu options and a host of configuration options are available. The two menu options are:

- „ CPU Feature
- „ Hard Disk Boot Priority

To access these menus, use the arrow keys to select the menu option and press the “**ENTER**” button. The menu will appear. The menus are discussed fully in **Section 5.3.1: CPU Feature** and **Section 5.3.2: Hard Disk Boot Priority** below.

### **Virus Warning [Disabled]**

When this item is enabled, the BIOS will monitor the boot sector and partition table of the HDD for any attempt at modification. If an attempt is made, the BIOS will halt the system and an error message will appear. Afterwards, if necessary, you will be able to run an anti-virus program to locate and remove the problem before any damage is done.

-  **Enabled**                      Activates automatically when the system boots up causing a warning message to appear when anything attempts to access the boot sector or HDD partition table.
-  **Disabled** (Default)      No warning message will appear when anything attempts to access the boot sector or HDD partition table.



#### **NOTE:**

Many disk diagnostic programs can cause the above warning message to appear when the program attempts to access the boot sector table. If you will be running such a program, it is recommended that you first disable the virus protection function before hand.

---

### ↑ CPU L1 & L2 Cache [Enabled]

The **CPU L1 & L2 Cache** option allows users to select whether the CPU primary cache (L1) and secondary cache (L2) will be turned on or off.

↑ **Enabled** (DEFAULT) The L1 and L2 CPU caches are both turned on

↑ **Disabled** The L1 and L2 CPU caches are both turned off

### ↑ Quick Power On Self Test [Enabled]

The **Quick Power On Self Test** configuration option speeds up the POST after you turn on the computer. If it is set to Enable, BIOS will shorten or skip some check items during POST.

↑ **Enabled** (DEFAULT) Quick POST will occur after the computer is turned on

↑ **Disabled** Normal POST will occur after the computer is turned on

### ↑ Boot Device

There are three **Boot Device** configuration options. They are:

- „ First Boot Device [DEFAULT: Floppy]
- „ **Second Boot Device** [DEFAULT: Hard Disk]
- „ Third Boot Device [DEFAULT: LS120]

The **Boot Device** configuration options allow you to select the order of devices the computer will boot from. Using the default values, the system will first look for a FDD to boot from. If it cannot find an FDD it will use an HDD to boot from. If both a FDD and a HDD are unavailable then the system will boot from a LS120 drive.

**Boot Device** configuration options are:

- „ Floppy
- „ LS120
- „ Hard Disk
- „ CDROM
- „ ZIP100

- „ USB-FDD
- „ USB-ZIP
- „ USB-CDROM
- „ LAN
- „ Disabled

#### **Boot Other Device [Enabled]**

The **Boot Other Device** option determines whether the CPU card will use a second or third boot device if the first boot device is not found.

 **Enabled** (DEFAULT) The system will look for second and third boot devices if the first one is not found.

 **Disabled** The system will not look for second and third boot device if the first one is not found.

#### **Boot Up Floppy Seek [Enabled]**

During the POST, BIOS will determine if the floppy disk drive installed has 40 or 80 tracks. 360K FDDs have 40 tracks while 760K, 1.2M and 1.44M FDDs all have 80 tracks

 **Enabled** BIOS searches for a FDD to determine if it has 40 or 80 tracks. Note that BIOS cannot tell the difference between 720K, 1.2M or 1.44M drives as they all have 80 tracks.

 **Disabled** (DEFAULT) BIOS will not search for the type of FDD drive by track number. Note that there will not be any warning message if the drive installed is 360K.

#### **Boot Up Numlock Status [On]**

The **Boot Up Numlock Status** option allows you to determine the default state of the numeric keypad.

 **Off** The keys on the keypad will be arrow keys

 **On** (DEFAULT) The keys on the keypad will be number keys

 **Typematic Rate Setting [Disabled]**

Disabling the **Typematic Rate Setting** configuration option only allows one character to appear onto the screen if a key is continuously held down. In other words, the BIOS will only report the key is down. When this option is enabled, the BIOS will report as before, but it will then wait a moment, and, if the key is still down, it will begin to report that the key has been depressed repeatedly. Such a feature would be used to accelerate cursor movements with the arrow keys.

 **Disabled** (DEFAULT) Disables the typematic rate

 **Enabled** Enables the typematic rate

 **x Typematic Rate (Chars/sec) [6]**

The **Typematic Rate** can only be configured if the **Typematic Rate Setting** is Enabled. The **Typematic Rate** configuration field determines the rate keys are accelerated.

 **6** (DEFAULT) 6 characters per second

 **8** 8 characters per second

 **10** 10 characters per second

 **12** 12 characters per second

 **15** 15 characters per second





 **20** 20 characters per second

 **24** 24 characters per second

 **30** 30 characters per second



### x **Typematic Delay (Msec) [250]**

The **Typematic Delay** can only be configured if the **Typematic Rate Setting** is enabled. The **Typematic Delay** configuration field allows you to select the delay between when the key was first depressed and when the acceleration begins.

	<b>250</b>	(DEFAULT)	250	milliseconds
	<b>500</b>		500	milliseconds
	<b>750</b>		750	milliseconds
	<b>1000</b>		1000	milliseconds

### **Security Option [Setup]**

The **Security Option** configuration option allows you to limit access to the system and Setup or just to the Setup.

	<b>Setup</b>	(DEFAULT)	The system will not boot and access to Setup will be denied if the correct password is not entered at the prompt.
	<b>System</b>		The system will boot, but access to Setup will be denied if the correct password is not entered at the prompt.



#### **NOTE:**

To disable security, select the password setting in the **Main Menu**. When asked to enter a password, do not type anything, press, “**ENTER**” and the security is disabled. Once the security is disabled, the system will boot and you can enter Setup freely.

---

## **APIC Mode [Enabled]**

The **APIC Mode** (Advanced Programmable Interrupt Controller mode) option is a BIOS setting made available to Windows 2000 and Windows XP systems that increases the number of IRQ (Interrupt Request) lines available to the processor from 16 to 23.

 **Enabled** IRQ lines increased from 16 to 23

 **Disabled** (DEFAULT) Only 16 IRQ lines are available to the CPU

## **MPS Version Control for OS [1.4]**

The **Multiprocessor Specification (MPS) for OS** specifies the MPS version to be used.

 **1.1** MPS version 1.1 is used

 **1.4** (DEFAULT) MPS version 1.4 is used

## **OS Select For DRAM > 64MB [Non-OS2]**

The **OS Select For DRAM > 64MB** option allows you to specify the operating system you are using.

 **Enabled** Only select this if you are using the OS/2 operating system

 **Disabled** (DEFAULT) If you are not using the OS/2 operating system then disable this function.

## **Report No FDD For WIN 95 [No]**

The **Report No FDD For WIN 95** option allows you to release IRQ6 if you are using Windows 95 or Windows 98 without a floppy disk.

 **No** (DEFAULT) Will not report that an FDD is not being used.

 **Yes** Will report that an FDD is not being used.

### ↑ Small Logo (EPA) Show [Disabled]

The **Small Logo (EPA) Show** option determines if the Environmental Protection Agency (EPA) logo will appear during the system boot-up process. If it is enabled then the boot up process may be delayed.

↑ **Enabled** EPA logo will appear during the boot up process.

↑ **Disabled** (DEFAULT) EPA logo will not appear during the boot up process.

## 5.3.1 CPU Feature

The **CPU Feature** menu (**BIOS Menu 5**) shows CPU configuration options.

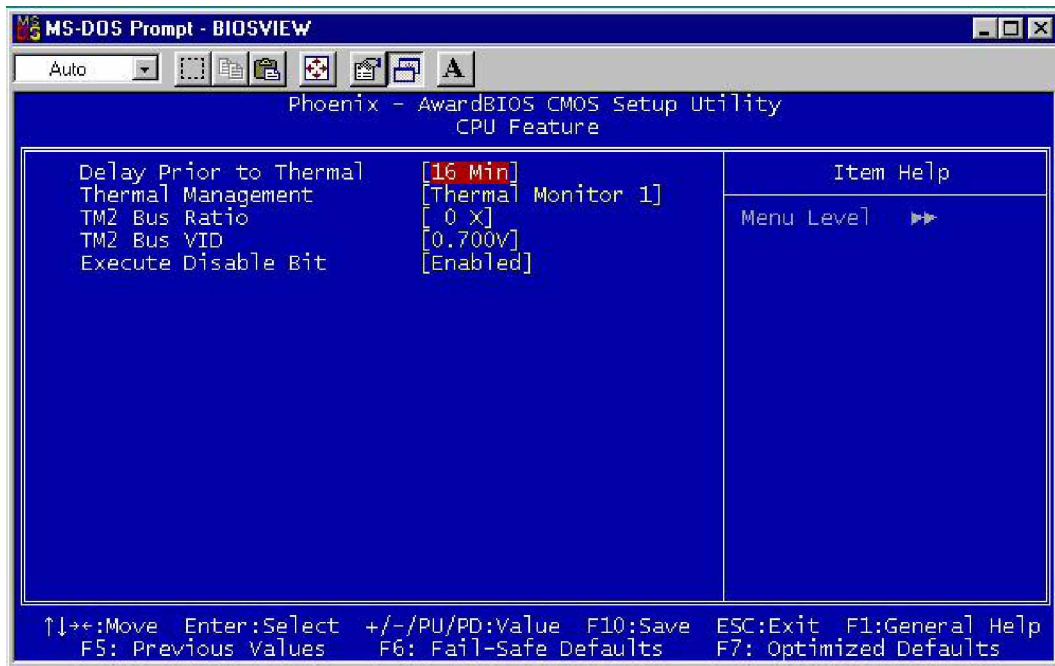



**BIOS Menu 5: CPU Feature**

### ↑ Delay Prior to Thermal [16min]

The **Delay Prior To Thermal** BIOS feature controls the activation of the thermal monitor's automatic mode. It allows you to determine when the thermal monitor for the CPU should be activated in automatic mode after the system boots.

↑ **4 Min** The thermal monitor is activated in automatic mode 4

-  **8 Min** minutes after the systems starts booting up  
The thermal monitor is activated in automatic mode 9 minutes after the systems starts booting up
-  **16 Min** (DEFAULT) The thermal monitor is activated in automatic mode 16 minutes after the systems starts booting up
-  **32 Min** The thermal monitor is activated in automatic mode 32 minutes after the systems starts booting up

### **Thermal Management [Thermal Monitor 1]**

The **Thermal Management** configuration option allows you to select the thermal monitor the CPU will use to monitor its own operating temperature. Once the thermal monitor detects that the CPU is reaching its maximum operating temperature, the thermal monitor will automatically throttle the CPU (reduce the number of CPU processing cycles) in order to cool the CPU down to a safe operating temperature. Once at a safe operating temperature, the CPU will continue to perform at its peak capacity.

 **Thermal Monitor 1** (DEFAULT) Thermal Monitor 1 uses an on-die temperature sensing circuit in the CPU that can act quickly in response to thermal issues. This circuit monitors the most active areas of the CPU-die at all times and will quickly lower the CPU temperature by throttling the internal CPU clock speed when the CPU approaches its maximum operating temperature.

 **Thermal Monitor 2** Thermal Monitor 2 decreases or increases the CPU clock and core voltage according to the CPU load. The CPU temperature is also automatically decreased, when the core voltage is decreased.



### ↑ x TM2 Bus Ratio [15 X]

The **TM2 Bus Ratio** configuration can only be configured if the **Thermal Monitor 2** is specified as the thermal management option in the **Thermal Management** configuration option above.

### ↑ x TM2 BUS VID [0.860V]

The **TM2 Bus VID** configuration can only be configured if the **Thermal Monitor 2** is specified as the thermal management option in the **Thermal Management** configuration option above.

### ↑ Execute Disable Bit [Enabled]

The **Execute Disable Bit** configuration option is a hardware configuration feature that protects the CPU from a buffer overflow attack. It is recommended that you enable this option.

- ↑ **Disabled** Forces the XD feature flag to always return to 0
- ↑ **Enabled** (DEFAULT) Does not force the XD feature flag to return to 0

### 5.3.2 Hard Disk Boot Priority

The **Hard Disk Boot Priority** menu (**BIOS Menu 6**) is shown below.

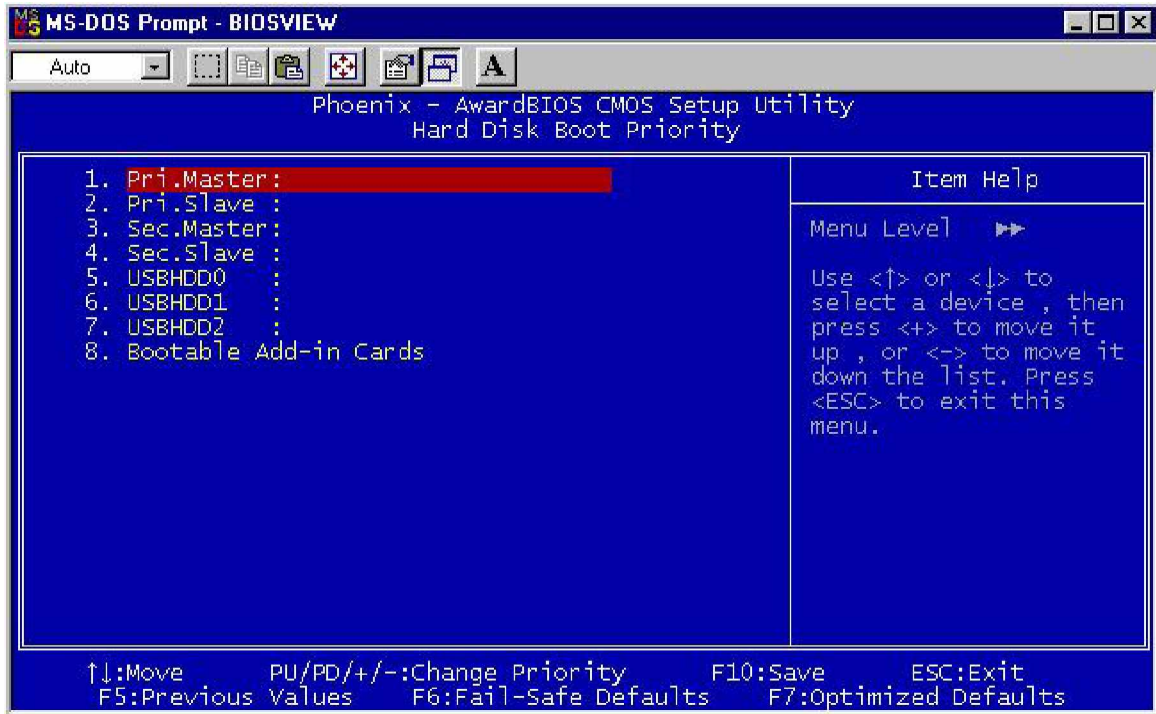

**BIOS Menu 6: Hard Disk Boot Priority**

## 5.4 Advanced Chipset Features

The **Advanced Chipset Features** menu (**BIOS Menu 7**) allows you to change the configuration for the chipset configuration options.

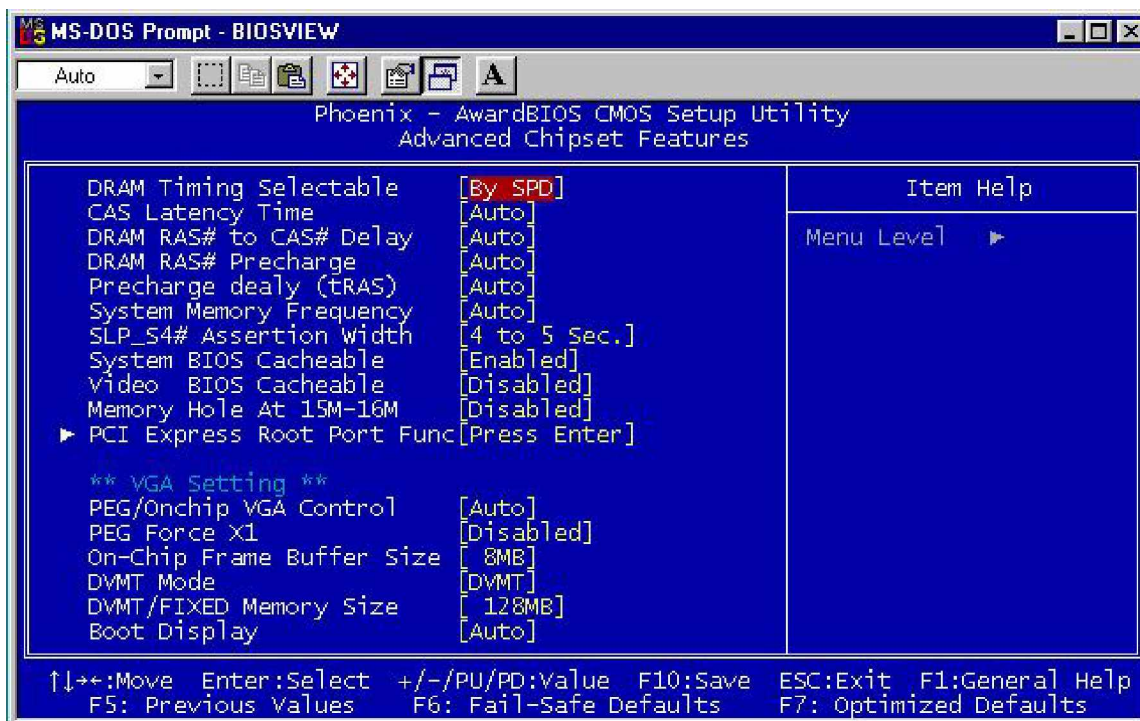

### BIOS Menu 7: Advanced Chipset Features

#### 📁 DRAM Latency Timing [By SPD]

The **DRAM Latency Timing** configuration option allows you to select whether the manufacturer recommended settings for the following DRAM configuration options are automatically detected by the BIOS or if you manually select the DRAM settings. The DRAM configuration options are:

- „ CAS Latency Time [4]
- „ DRAM RAS# to CAS# Delay [4]
- „ DRAM RAS# Precharge [4]
- „ Precharge Delay (tRAS) [12]
- „ System Memory Frequency [533MHz]

- ↑ **Manual** You set the above configuration options manually
- ↑ **By SPD** (DEFAULT) The BIOS automatically detects the settings recommended by the manufacturer

## ↑ **CAS Latency Time [4]**

The **CAS Latency Time** configuration option refers to the Column Address Strobe (CAS) delay time. (To be able to change this configuration option the **DRAM Latency Timing** configuration option must be set to “**Manual**”) The following configuration options are available

- „ 5 nanoseconds
- „ 4 nanoseconds (DEFAULT)
- „ 3 nanoseconds
- „ Auto

## ↑ **DRAM RAS# to CAS# Delay [4]**

The **DRAM RAS# to CAS# Delay** refers to the Row Address Strobe (RAS) to CAS delay time. (To be able to change this configuration option the **DRAM Latency Timing** configuration option must be set to “**Manual**”) The following configuration options are available

- „ 2 nanoseconds
- „ 3 nanoseconds
- „ 4 nanoseconds (DEFAULT)
- „ 5 nanoseconds
- „ Auto

## ↑ **DRAM RAS# Precharge [4]**

The **DRAM RAS# Precharge** option indicates how fast your RAM can terminate the access of one row and start accessing another. (To be able to change this configuration

option the **DRAM RAS# Precharge** configuration option must be set to “**Manual**”) The following configuration options are available

- ” 2 nanoseconds
- ” 3 nanoseconds
- ” 4 nanoseconds (DEFAULT)
- ” 5 nanoseconds
- ” Auto

#### **Precharge dealy (tRAS) [12]**

The **Precharge Dealy** option allows you to set the time it takes for the RAS to start retrieving the actual data after a request has been issued to the memory module. (To be able to change this configuration option the **DRAM RAS# Precharge** configuration option must be set to “**Manual**”) The following configuration options are available,

- ” Auto
- ” 2 nanoseconds
- ” 3 nanoseconds
- ” 4 nanoseconds
- ” 5 nanoseconds
- ” 6 nanoseconds
- ” 7 nanoseconds
- ” 8 nanoseconds
- ” 9 nanoseconds
- ” 10 nanoseconds
- ” 11 nanoseconds
- ” 12 nanoseconds (DEFAULT)
- ” 13 nanoseconds
- ” 14 nanoseconds
- ” 15 nanoseconds

#### **System Memory Frequency**

The **System Memory Frequency** configuration option allows you to manually select the speed of the installed memory module. The default value is 533MHz. If you are not certain of what value to select, select “**Auto**” and the BIOS will automatically detect the speed.

(To be able to change this configuration option the **DRAM RAS# Precharge** configuration option must be set to “**Manual**”) The following configuration options are available,

- „ Auto
- „ 333MHz
- „ 400MHz
- „ 533MHz (DEFAULT)

### **SLP\_S4# Assertion Width [4 to 5 sec]**

The following configuration options are available,

- „ 4 to 5 sec (DEFAULT)
- „ 3 to 4 sec
- „ 2 to 3 sec
- „ 1 to 2 sec

### **System BIOS Cacheable [Enabled]**

The **System BIOS Cacheable** option allows the system BIOS to be cached in the L2 cache.

 **Disabled** System BIOS is not cached in the L2 cache

 **Enabled** (DEFAULT) System BIOS is cached in the L2 cache

### **Video BIOS Cacheable [Disabled]**

The **Video BIOS Cacheable** option allows the video BIOS to be cached in the L2 cache.

 **Disabled** Video BIOS is not cached in the L2 cache

 **Enabled** (DEFAULT) Video BIOS is cached in the L2 cache

### **Memory Hole At 15M – 16M [Disabled]**

The **Memory Hole At 15M – 16M** reserves the memory space between 15MB and 16MB for ISA expansion cards that require a specified area of memory to work properly. If you

are using older ISA expansion cards, please refer to the documentation that came with the card to see if it is necessary to reserve the space.

↑ **Disabled** (DEFAULT) Memory is not reserved for ISA expansion cards

↑ **Enabled** Memory is reserved for ISA expansion cards

#### ↑ **PCI Express Root Port Func. [Press Enter]**

When you select this option the **PCI Express Port Functions** menu (**BIOS Menu 7**) appears:

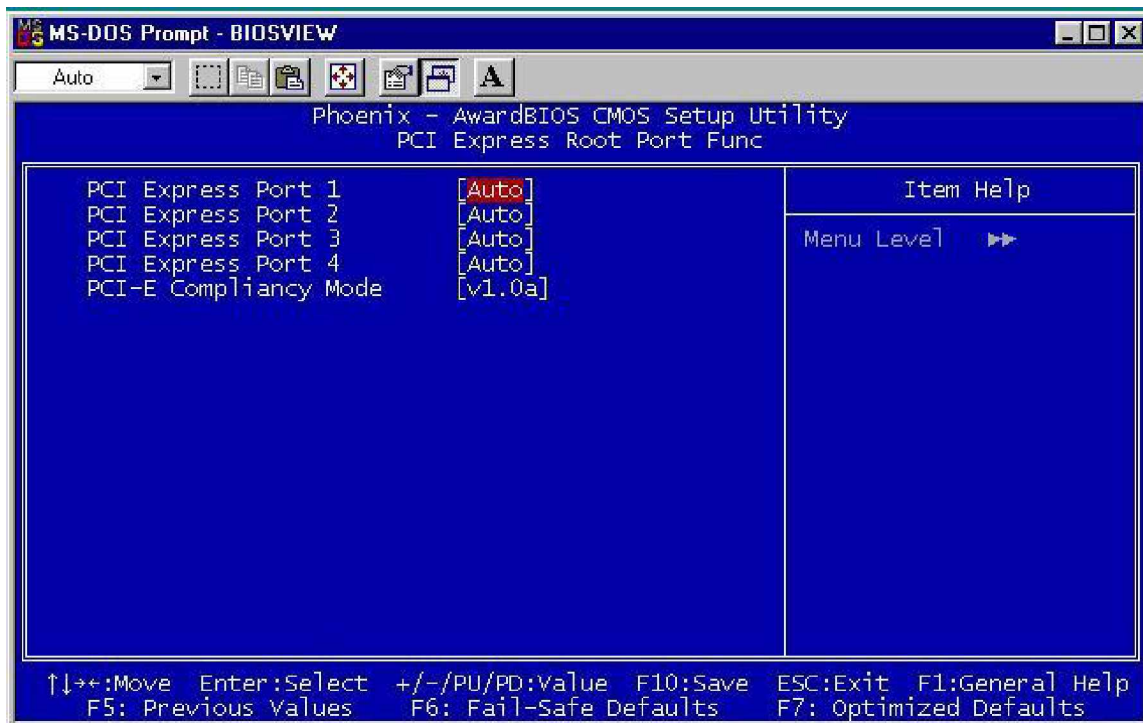

#### **BIOS Menu 8: PCI Express Port Functions**

##### ↑ **PEG/Onchip VGA Control [Auto]**

The **PEG/Onchip VGA Control** option is found on motherboards that have a built-in graphics processor as well as a PCI-E port. It allows you to select whether to use the onboard graphics processor or the PCI-E card.

 **On-Chip VGA**                      The system will boot up using the on-chip graphics processor regardless of whether or not a PCI graphics card is installed.

 **PEG Port**                              The system will boot up using the installed PCI graphics card.

**Auto**                      (DEFAULT)      During the boot process, the BIOS will automatically detect to see if there is a PCI graphics card installed. If no card is installed then the system will automatically boot using the on-chip graphics processor.

## **On-Chip Frame Buffer Size [8MB]**

The **On-Chip Frame Buffer Size** option allows you to allocate a predetermined amount of system memory to the graphics processor when the system boots up.

 **1MB**                              1MB of system memory is allocated to the graphics processor

 **8MB**                      (DEFAULT)      8MB of system memory is allocated to the graphics processor

## **DVMT Mode [DVMT]**

The **DVMT Mode** option allows you to control Intel's Dynamic Video Memory Technology (DVMT). The key idea in DVMT is to improve the efficiency of the memory allocated to either system or

 **Fixed**                              A fixed amount of memory is allocated as graphics memory to ensure that the graphics memory will always be sufficient. Once the memory has been allocated as graphics memory it cannot be accessed by the system.





 **DVMT** (DEFAULT) The graphics chip assesses the system and graphics memory requirement and dynamically allocates memory either as graphics memory or system memory according to the predetermined needs.

 **Both** A fixed amount of memory will be set as graphics memory but if more graphics memory is required, more memory will be allocated to meet the graphics memory needs.

### **DVMT/FIXED Memory Size [128MB]**

The **DVMT/FIXED Memory Size** option allows you to determine the maximum amount of memory that may be allocated as fixed graphics memory.

 **64MB** The maximum amount of fixed memory allocated to graphics memory is 64MB

 **128MB** (DEFAULT) The maximum amount of fixed memory allocated to graphics memory is 128MB

### **Boot Display [Auto]**

The **Boot Display** option allows you to select the display device the system will boot with.

 **Auto** (DEFAULT) The system will automatically determine the display device type.

 **CRT** The display device type will be set as CRT

 **TV** The display device type will be set as TV

 **EFP** The display device type will be set as EFP

## 5.5 Integrated Peripherals

The **Integrated Peripherals** menu (**BIOS Menu 9**) allows you to change the configuration option for peripheral devices.

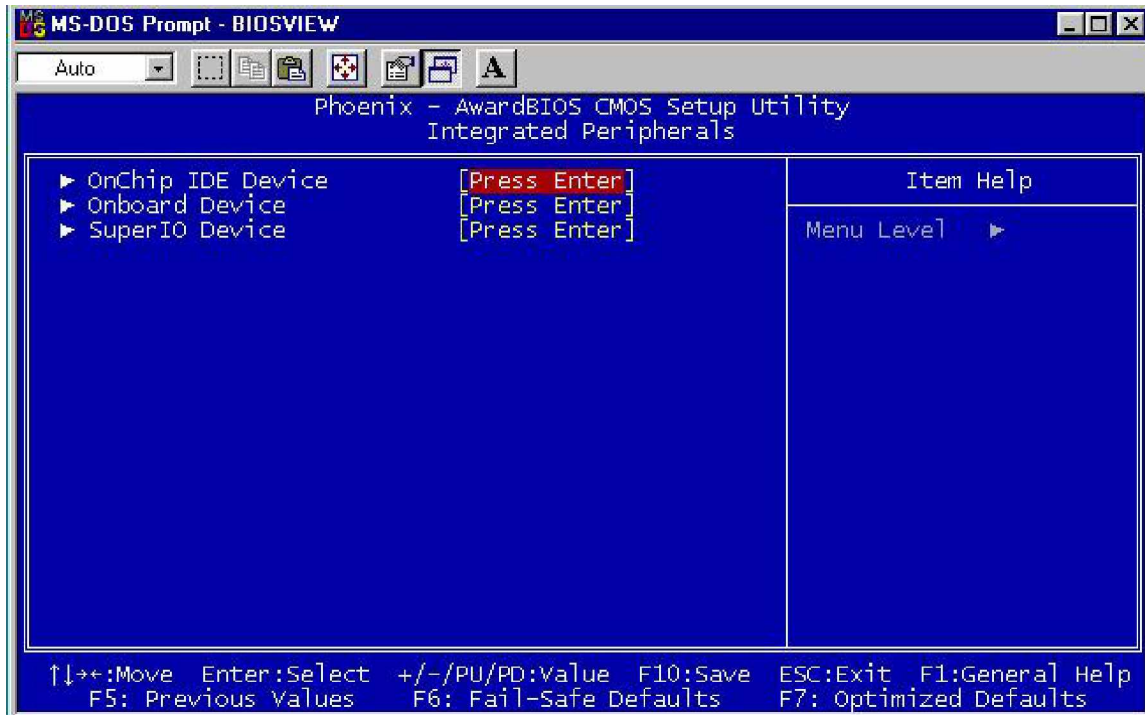

### BIOS Menu 9: Integrated Peripherals

The **Integrated Peripherals** menu (**BIOS Menu 9**) has three options listed below:

- „ OnChip IDE Device
- „ Onboard Device
- „ Super IO Device

All three options are menus. Select the menu you wish to configure.

#### 5.5.1 OnChip IDE Device

The **OnChip IDE Device** menu (**BIOS Menu 10**) allows you to change the IDE device configurations.

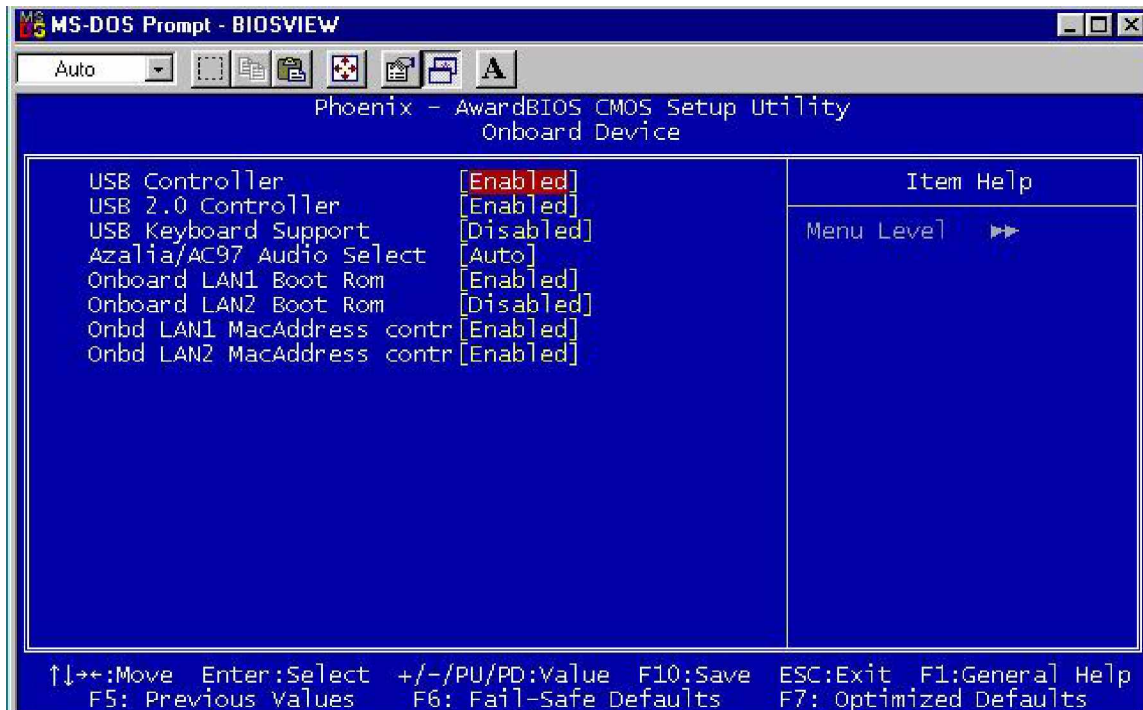

## BIOS Menu 10: Integrated Peripherals

### ↑ IDE HDD Block Mode [Enabled]

The **IDE HDD Block Mode** option should only be enabled if your IDE HDD device supports block mode. Please refer to the documentation that came with your IDE HDD device to check the compatibility.

↑ **Disabled** The BIOS will not detect block data transfers.

↑ **Enabled** (DEFAULT) The optimal number of block read/writes per sector the drive can support will be automatically detected.

### ↑ IDE DMA transfer access [Enabled]

The **IDE DMA transfer access** option allows you to determine whether or not the IDE device installed in the system will have a DMA device.

↑ **Disabled** The IDE HDD installed in the system will not have DMA transfer access

 **Enabled** (DEFAULT) The IDE HDD installed in the system will have DMA transfer access

### **On-Chip Primary PCI IDE [Enabled]**

The **On-Chip Primary PCI IDE** option allows you to determine whether or not the 3301650 will use the integrated primary IDE channel.

 **Disabled** The CPU card will not use the primary IDE channel

 **Enabled** (DEFAULT) The CPU card will use the primary IDE channel

### **IDE PIO [Auto]**

The Programmed Input/Output (PIO) mode for the following HDDs can all be selected.

- „ IDE Primary Master PIO
- „ IDE Primary Slave PIO
- „ IDE Secondary Master PIO
- „ IDE Secondary Slave PIO

 **Auto** (DEFAULT) Allows the computer to select the correct mode

 **0** PIO mode 0 selected with a maximum transfer rate of 3.3MBps

**1** PIO mode 1 selected with a maximum transfer rate of 5.2MBps

**2** PIO mode 2 selected with a maximum transfer rate of 8.3MBps

**3** PIO mode 3 selected with a maximum transfer rate of 11.1MBps

**4** PIO mode 4 selected with a maximum transfer rate of 16.6MBps

### **IDE UDMA [Auto]**

The Ultra DMA (UDMA) mode for the following HDDs can all be selected.

- „ IDE Primary Master UDMA
- „ IDE Primary Slave UDMA

„ IDE Secondary Master UDMA

„ IDE Secondary Slave UDMA

”

 **Auto** (DEFAULT) Allows the computer to select the correct UDMA

 **Disabled** Disables the UDMA for the HDD device

### **On-Chip Secondary PCI IDE [Auto]**

The **On-Chip Secondary PCI IDE** option allows you to determine if the motherboard should or should not use the integrated primary IDE channel. Disable this if you use an IDE adapter card for your IDE hard drives.

 **Disabled** The CPU card will not use the integrated primary IDE channel

 **Enabled** (DEFAULT) The CPU card will use the integrated primary IDE channel

### **On Chip Serial ATA [Disabled]**

The **On Chip Serial ATA (SATA)** option allows you to determine the operational status of the onboard SATA controller.

 **Disabled** (DEFAULT) The SATA controller is disabled

 **Auto** The SATA controller is automatically arranged by the BIOS

 **Combined Mode** PATA and SATA modes are combined together.

A maximum of 2 IDE drives in each channel

 **Enhanced Mode** Enable both PATA and SATA. A maximum of 6 IDE drives are supported.

 **SATA Only** SATA is operating in legacy mode.

### ↑ x PATA IDE Mode [Secondary]

When the **On Chip Serial ATA** option is in the combined mode, the PATA IDE Mode will be selected as **secondary**.

### ↑ SATA Port

The **SATA Port** parameter is automatically detected by the system BIOS and shown on the screen. This parameter is not user configurable.

## 5.5.2 OnBoard Device

The **OnBoard Device** menu (**BIOS Menu 11**) allows you to change the USB and LAN device configurations.

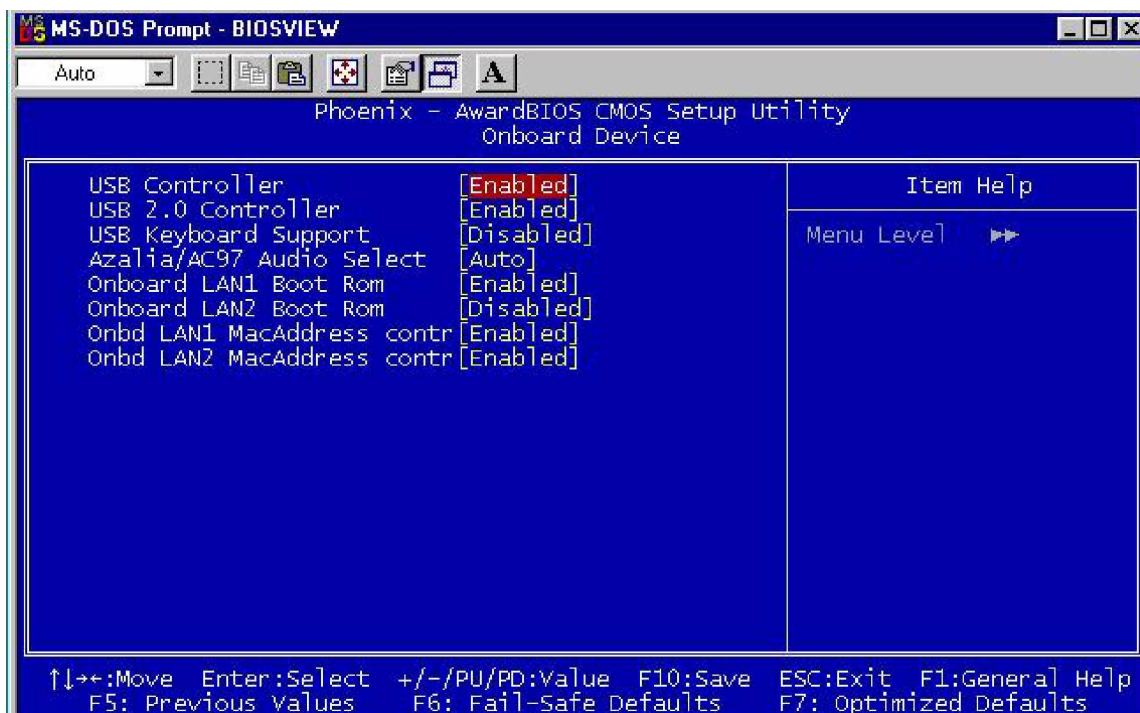

### BIOS Menu 11: OnBoard Device [Integrated Peripherals]

#### ↑ USB Controller [Enabled]

The **USB Controller** option allows you to activate or deactivate the onboard USB controller.

 **Enabled** (DEFAULT) The USB controller is activated

 **Disabled** The USB controller is deactivated

#### **USB 2.0 Controller [Enabled]**

The **USB 2.0 Controller** option allows you to activate or deactivate the onboard EHCI controller.

 **Enabled** (DEFAULT) The EHCI controller is activated

 **Disabled** The EHCI controller is deactivated

#### **USB Keyboard Support [Disabled]**

The **USB Keyboard Support** is only applicable if you are using a USB keyboard. Some OSes do not support USB keyboards. Enabling this option in BIOS will allow users using an OS that does not support USB keyboard to implement a USB keyboard.

 **Disabled** (DEFAULT) USB keyboard support no provided by BIOS

 **Enabled** USB keyboard support is provided by BIOS

#### **Azalia/AC97 Audio Select [Auto]**

The **Azalia/AC97 Audio Select** option allows the user to select the standard that will be used by the system.

 **Auto** (DEFAULT) The BIOS automatically detects the audio standard

 **Azalia** Azalia is selected as the audio standard

**AC'97 Audio and Modem** AC'97 is for both audio and modem is set as the audio standard

**AC'97 Audio only** AC'97 audio is set as the audio standard

**AC'97 Modem only**

AC'97 modem is set as the audio standard

**All Disabled**

No audio standard is set

## **Onboard LAN1/2 Boot Rom [Enabled]**

The **Onboard LAN Boot Rom** allows you to boot your system from a LAN server. For this to be possible the LAN card installed on your system must have boot ROM. If you choose to boot your system from a server using the LAN boot ROM functionality, you do not need a boot disk installed on the system.



**Disabled**

If disabled, you will not be able to boot your system from a server.



**Enabled**

(DEFAULT)

You will be able to boot your system from a server if the LAN card installed in the system has boot ROM

## **Onbd LAN1/2 MacAddress contr [Enabled]**



**Disabled**



**Enabled**

(DEFAULT)

### **5.5.3 SuperIO Device**

The **SuperIO Device** menu (**BIOS Menu 12**) allows you to change the super IO device configurations.



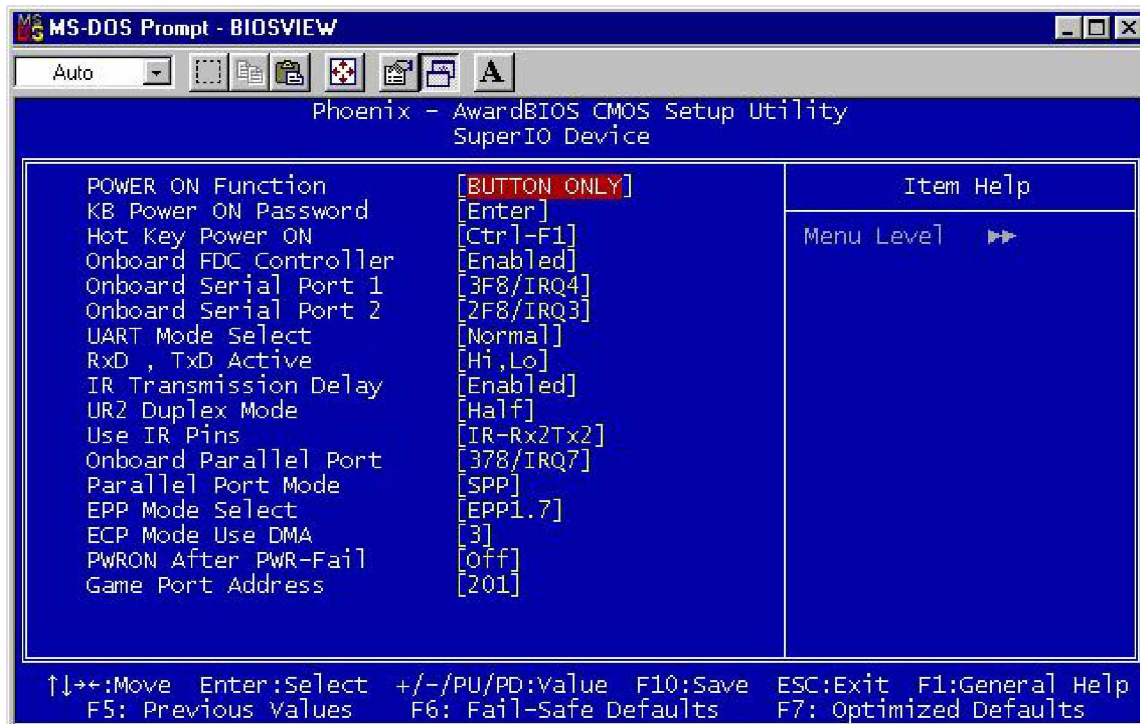

## BIOS Menu 12: SuperIO Device [Integrated Peripherals]

### ↑ POWER ON Function [BUTTON ONLY]

The **POWER ON Function** option allows you to select the method you use to turn on the system.

#### ↑ Password

When you turn on the computer you will be prompted for a password (see the **KB Power ON Password** option below)

#### ↑ Hot KEY

You can use a pre-specified hot key to turn on your computer (see the **Hot Key Power ON** option below)

#### ↑ Mouse Left

Click the left mouse button to turn the system on

#### ↑ Mouse Right

Click the right mouse button to turn the system on

#### ↑ Any KEY

Click any key to turn the system on

 **BUTTON ONLY** (DEFAULT) The computer can only be turned on with the power button

 **Keyboard 98** If you are using Windows 98 or better and have the appropriate keyboard, you can use the keyboard's wake-up or power-on button to start up the computer.

 **x KB Power ON Password [Enter]**

The **KB Power ON Password** option can only be specified if you have selected the **Password** as the **POWER ON Function** option. To set the password, place the cursor on the password option and click “**ENTER.**” You will be prompted to enter a password. Select your password and press “**ENTER.**” You will be asked to confirm the password. Confirm it and then press “**ENTER**” and the password will be set.

 **x Hot Key Power ON [Ctrl-F1]**

The **Hot Key Power ON** option can only be specified if you have selected the **Hot KEY** as the **POWER ON Function** option. The following key combinations can be selected as the hot keys that will turn your computer on.

- ” Ctrl-F1
- ” Ctrl-F2
- ” Ctrl-F3
- ” Ctrl-F4
- ” Ctrl-F5
- ” Ctrl-F6
- ” Ctrl-F7
- ” Ctrl-F8
- ” Ctrl-F9
- ” Ctrl-F10
- ” Ctrl-F11
- ” Ctrl-F12

### ↑ Onboard FDC Controller [Enabled]

The **Onboard FDC Controller** allows you to select whether the onboard floppy controller will or will not be used.

↑ **Disabled** Disable this option if you use an adapter for your FDDs or if you have no FDDs connected

↑ **Enabled** (DEFAULT) Select this option if FDDs are connected to the board and will use the onboard FDD controller.

### ↑ Onboard Serial Port 1 [3F8/IRQ4]

The **Onboard Serial Port 1** option allows you to select the I/O address and IRQ for the onboard serial port. The serial port can be disabled or the I/O address and the IRQ can be automatically selected by the BIOS. The options are listed below:

- „ Disabled
- „ 3F8/IRQ4 (DEFAULT)
- „ 2F8/IRQ3
- „ 3E8/IRQ4
- „ 2E8/IRQ3
- „ Auto

### ↑ Onboard Serial Port 2 [3F8/IRQ4]

The **Onboard Serial Port 2** option allows you to select the I/O address and IRQ for the onboard serial port. The serial port can be disabled or the I/O address and the IRQ can be automatically selected by the BIOS. The options are listed below:

- „ Disabled
- „ 3F8/IRQ4
- „ 2F8/IRQ3 (DEFAULT)
- „ 3E8/IRQ4
- „ 2E8/IRQ3
- „ Auto

**↑ UART Mode Select**

The **UART Mode Select** option allows you to select the UART mode for the system.

**↑ IrDA** IrDA is set as the IR serial mode. If this option is selected, COM2 will be disabled.

**↑ ASKIR** ASKIR is set as the IR serial mode. If this option is selected, COM2 will be disabled.

**↑ Normal** (DEFAULT) COM2 is enabled and the IR device disabled

**↑ x RxD, TxD Active [Hi,Lo]**

The **RxD, TxD Active** BIOS option allows you to set the infra-red reception (RxD) and transmission (TxD) polarity. (This option can only be selected if the UART is set in IrDA mode or ASKIR mode.) The following configuration options are available,

- „ Hi, Hi
- „ Hi, Lo (DEFAULT)
- „ Lo, Hi
- „ Lo, Lo

**↑ x IR Transmission Delay [Enabled]**

**↑ Disabled**

**↑ Enabled** (DEFAULT)

**↑ UR2 Duplex Mode [Half]**

**↑ Full**

**↑ Half** (DEFAULT)

**↑ Use IR Pins [IR-Rx2Tx2]**

**↑ RxD2, TxD2**

**↑ IR-Rx2Tx2** (DEFAULT)

## ↑ Parallel Port Mode [SPP]

The **Parallel Port Mode** selection allows you to select the mode the parallel port will operate in.

↑ **SPP** (DEFAULT) The parallel port will operate in the standard parallel port (SPP) mode. This parallel port mode will work with most parallel port devices but is slow.

↑ **EPP** The parallel port will operate in the enhanced parallel port mode (EPP). The EPP mode supports bi-directional communication between the system and the parallel port device and the transmission rates between the two are much faster than the SPP mode.

↑ **ECP** The parallel port will operate in the extended capabilities port (ECP) mode. The ECP mode supports bi-directional communication between the system and the parallel port device and the transmission rates between the two are much faster than the SPP mode.

↑ **ECP+EPP** The parallel port will be compatible with both ECP and EPP devices

↑ **Normal**

## ↑ x EPP Mode Select

If the **EPP mode** is selected in the **Parallel Port Mode** configuration option, you will be able to configure the **EPP Mode Select** option. The EPP parallel port mode has two standards, EPP 1.7 and EP 1.9. This selection allows you to choose the standard the parallel port will operate in. Please refer to the parallel device that your system will be connected to and select the EPP mode accordingly.

↑ **EPP1.9** EPP 1.9 is selected as the EPP standard

 **EPP1.7** (DEFAULT) EPP 1.7 is selected as the EPP standard

### x **ECP Mode Use DMA [3]**

If the **ECP mode** is selected in the **Parallel Port Mode** configuration option, you will be able to configure the **ECP Mode Use DMA** option. This option determines the DMA channel the parallel port uses when it is in the ECP mode.

 1 Parallel port uses DMA Channel 1 in the ECP mode

 3 (DEFAULT) Parallel port uses DMA Channel 3 in the ECP mode

### **PWRON After PWR-Fail [Off]**

This **PWRON After PWR-Fail** option allows you to select the state the system will return to if there is a power failure or power to the system is suddenly cut off.

 **Off** (DEFAULT) After the power returns the system will remain off.

 **On** After the power returns, the system will turn on

 **Former-Sts** After the power returns the system will return to its original state. If it was off, it will remain off. If it was on, it will turn on again.

### **Game Port Address [201]**

The Game Port Address configuration option allows you to specify the game port address.

 **Disabled** When disabled, the onboard game port will be unable to access any system resources and will in effect be inaccessible.

 **201** (DEFAULT) The game board address is set to 201

 **209** The game board address is set to 209

## 5.6 Power Management Setup

The **Power Management Setup** menu (**BIOS Menu 9**) allows you to set the power management and saving features in the BIOS.

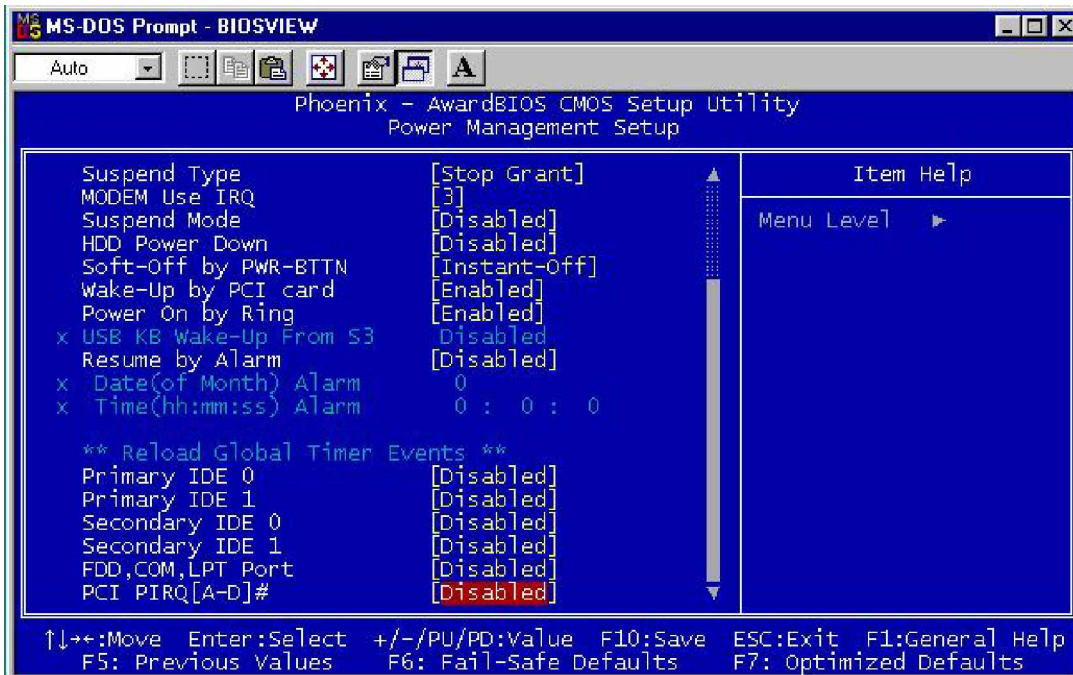
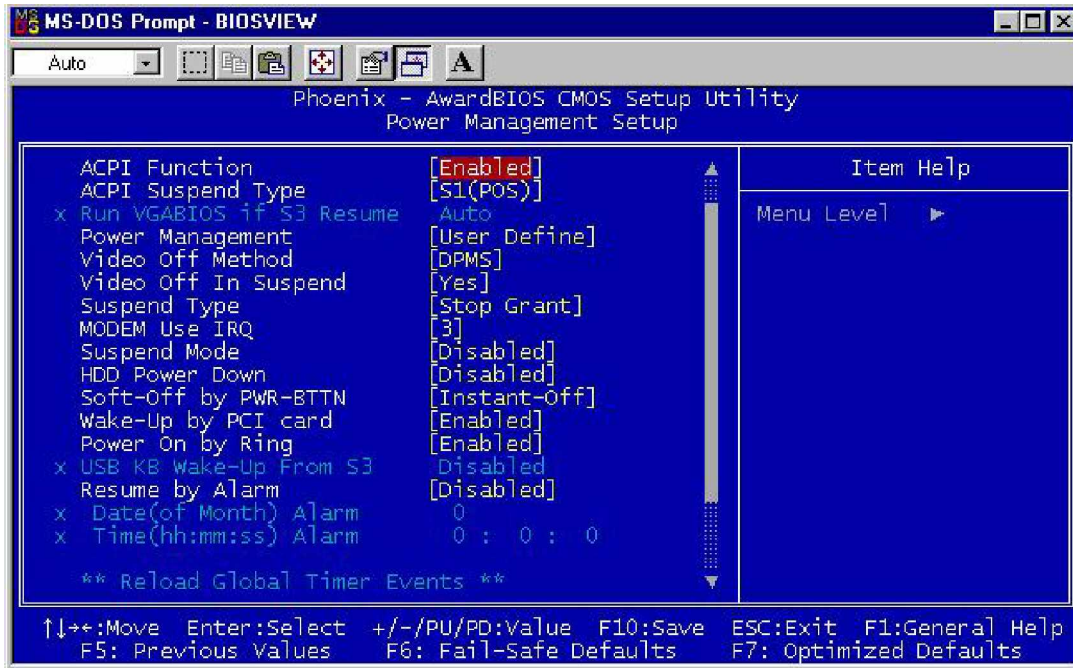

**BIOS Menu 13: Power Management Setup**

### ↑ **ACPI Function [Enabled]**

The **ACPI Function** option allows you to enable or disable the ACPI function.

↑ **Disabled** The ACPI function is enabled

↑ **Enabled** (DEFAULT) The ACPI function is disabled

### ↑ **ACPI Suspend Type [S1(POS)]**

The **ACPI Suspend Type** option allows you to select the suspend state your computer will go into during the power conservation mode.

↑ **S1(POS)** (DEFAULT) System appears off. The CPU is stopped; RAM is refreshed; the system is running in a low power mode.

↑ **S3(STR)** System appears off. The CPU has no power; RAM is in slow refresh; the power supply is in a reduced power mode.

↑ **S1&S3** The BIOS will be able to support both the S1 and the S3 suspend states described above.

### ↑ **Run VGABIOS if S3 Resume [Auto]**

If the **S3(STR)** or **S1&S3** option is selected in **ACPI Suspend Type** above, you will be able to configure the **Run VGABIOS if S3 Resume** option. This option allows you to select whether or not to run the VGA BIOS after the system wakes up from an S3 sleep state.

↑ **Auto** (DEFAULT) The system BIOS automatically decides whether or not to run the VGA BIOS after the system resumes from a S3 sleep state.

↑ **Yes** The VGA BIOS will be run after the system resumes from a S3 sleep state.





-  **No**                      The VGA BIOS will not be run after the system resumes from a S3 sleep state.

### **Power Management [User Define]**

The **Power Management** option allows you to manually define the **Suspend Mode** and the **HDD Power Down** options. BIOS has preset minimum and maximum values for the **Suspend Mode** and the **HDD Power Down** options.

-  **User Define**      (DEFAULT)      The user defines the **Suspend Mode** time and the **HDD Power Down** time.

-  **Min. Saving**                      BIOS automatically sets the **Suspend Mode** time and the **HDD Power Down** time for minimum power saving.

-  **Max. Saving**                      BIOS automatically sets the **Suspend Mode** time and the **HDD Power Down** time for maximum power saving.

The minimum and maximum power settings are shown below:

	<b>Suspend Mode</b>	<b>HDD Power Down</b>
<b>Min. Saving</b>	1 hour	15 minutes
<b>Max. Saving</b>	1 minute	1 minute

### **Video Off Method [DPMS]**

The **Video Off Method** option allows you to specify what happens to the monitor in a power down mode.

-  **Blank Screen**                      Writes blanks to the video buffer and the monitor is black, but still active (not powered down).

 **V/H SYNC + Blank** Writes blanks to the video buffer and the monitor is black, but still active (not powered down)

 **DPMS** (DEFAULT) If your monitor supports Display Power Management Signaling, the monitor uses this to enter a power down mode.

### **Video Off In Suspend [Yes]**

The **Video Off In Suspend** option allows you to specify whether the display monitor is turned off or remains on when the systems enters a suspend state.

 **No** The display monitor will remain on when the system is in suspend mode.

 **Yes** (DEFAULT) The display monitor will be turned off when the system is in suspend mode.

### **Suspend Type [Stop Grant]**

The **Suspend Type** option allows you to determine what suspend state the CPU will go into when the system is in the suspend state.

 **Stop Grant** (DEFAULT) When the CPU is in the stop grant state the bus clock (BCLK) continues to run. Snoops and interrupts are also allowed in the stop grant state. Thus, the CPU can operate in a lower power state yet can respond to snoops and interrupts.

 **PwrON Suspend**

### **MODEM Use IRQ [3]**

The **MODEM Use IRQ** option tells the power management which IRQ it should monitor for modem wakeup. The following options can be selected.

- „ N/A
- „ 3 (Default)
- „ 4
- „ 5
- „ 7
- „ 9
- „ 10
- „ 11

### **Suspend Mode [Disabled]**

The **Suspend Mode** option allows you to specify how long the computer must wait for no activity before it goes into a suspend mode. If you disable this option the system will not go into a suspend mode. Note that if you selected max. or min. as the setting for the **Power Management** option, you will not be able to configure this setting. The following settings can be made.

- „ Disable (Default)
- „ 1 Min
- „ 2 Min
- „ 3 Min
- „ 4 Min
- „ 8 Min
- „ 12 Min
- „ 20 Min
- „ 30 Min
- „ 40 Min
- „ 1 Hour

### **HDD Power Down [Disabled]**

The **HDD Power Down** option allows you to specify how long the computer must wait for no activity before the HDD powers down. If you disable this option the HDD will not power down. Note that if you selected max. or min. as the setting for the **Power Management** option, you will not be able to configure this setting. The following settings can be made.

- „ Disable (Default)

- „ 1 Min
- „ 2 Min
- „ 3 Min
- „ 4 Min
- „ 5 Min
- „ 6 Min
- „ 7 Min
- „ 8 Min
- „ 9 Min
- „ 10 Min
- „ 11 Min
- „ 12 Min
- „ 13 Min
- „ 14 Min
- „ 15 Min

### **Soft –Off by PWR-BTTN [Instant-Off]**

The **Soft –Off by PWR-BTTN** option allows you to define how the system responds when the power button is pushed. You may choose to allow the system to be either turned off completely or enter into a suspend mode.

 **Instant-Off** (DEFAULT) The system will be turned off as soon as the power button is pressed.

 **Delay 4 Sec** The power button must be pressed for more than four seconds before it is turned off. If it is pressed for less than four seconds the system will enter a suspend state.

### **Wake-Up by PCI Card [Enabled]**

The **Wake-Up by PCI Card** option allows users to wake a system in a suspended state through a network. A wakeup signal from a network can be routed directly through the PCI card.

	<b>Disabled</b>		The system cannot be woken from a suspend state through the network via a PCI card
---	-----------------	--	--

	<b>Enabled</b>	(DEFAULT)	The system can be woken from a suspend state through the network via a PCI card
---	----------------	-----------	---

### **Power On by Ring [Enabled]**

The **Power On by Ring** option allows users to determine whether or not the system can be roused from a suspend state when the modem rings.

	<b>Disabled</b>		The system will not be woken from a suspend state when the modem rings
---	-----------------	--	--

	<b>Enabled</b>	(DEFAULT)	The system will be woken from a suspend state when the modem rings
---	----------------	-----------	--

### **USB KB Wake-Up From S3 [Disabled]**

If you selected either the S3(STR) or the S1&S3 option in the **ACPI Suspend Type** option, you will be able to configure the **USB KB Wake-Up From S3**. This option allows you to wake the system from an S3 suspend state using the keyboard.

	<b>Disabled</b>	(DEFAULT)	Keyboard cannot be used to rouse the system from the S3 suspend state
---	-----------------	-----------	---

	<b>Enabled</b>		Keyboard can be used to rouse the system from the S3 suspend state
---	----------------	--	--

### **Resume by Alarm [Disabled]**

The **Resume by Alarm** option allows you tell the computer when it should be roused from a suspend state.

	<b>Disabled</b>	(DEFAULT)	No time is specified for when the computer should be roused from a suspend state
---	-----------------	-----------	--

 **Enabled**

The date and time the computer must be roused from a suspend state is specified

 **x Date(of Month) Alarm [0]**

The **Date(of Month) Alarm** option can only be configured if the **Resume by Alarm** option has been enabled. When you select this option you will be asked to enter a number between 0 and 31 to specify the date of the current month that you would like the system to be roused.

 **x Time(hh:mm:ss) Alarm [0 : 0 : 0]**

The **Time(hh:mm:ss) Alarm** option can only be configured if the **Resume by Alarm** option has been enabled. You will have to set the time you wish the computer to be roused. You will see three zeroes side by side. The first zero is for the hour, the second zero for the minutes and the third zero for the seconds.

- „ Hour (first zero): Select a number between 0 and 23
- „ Minute (second zero): Select a number from 0 to 59
- „ Second (third zero): Select a number from 0 to 59

 **Reload Global Timer Events**

The **Reload Global Timer Events** field has the following BIOS configuration options

- „ Primary IDE 0
- „ Primary IDE 1
- „ Secondary IDE 0
- „ Secondary IDE 1
- „ FDD, COM, LPT Port
- „ PCI PIRQ[A-D]

All the above options have “**Disabled**” as their default value. When disabled, if any activity occurs on these devices during a suspended state, the system will not be roused.

If “**Enabled**” is selected for any of the above devices, and if activity is recorded on an enabled device in the above list the system will be roused from its suspended state.

## 5.7 PnP/PCI Configurations

The **PnP/PCI Configurations** menu (**BIOS Menu 9**) allows you to set the plug and play, and PCI options.

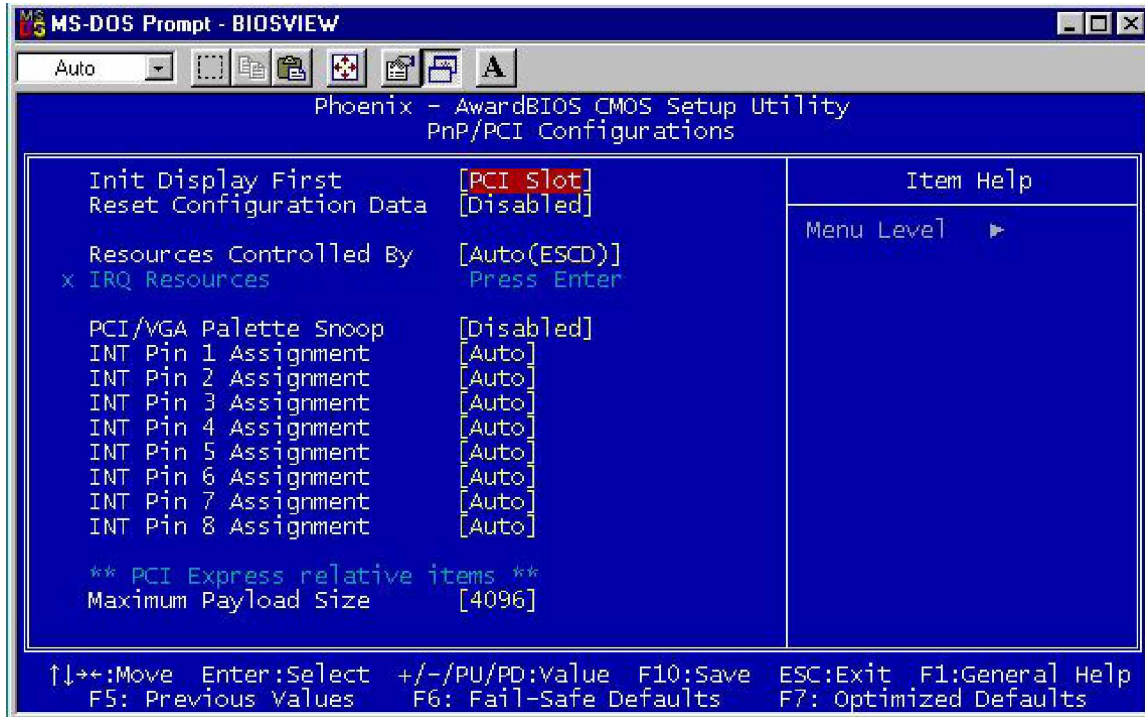

### BIOS Menu 14: PnP/PCI Configurations

#### ↑ Init Display First [PCI Slot]

The **Init Display First** option allows you to determine what display device to boot with.

- ↑ **PCI Slot** (DEFAULT) The system will boot using the PCI graphic card
- ↑ **Onboard** The system will boot using the preinstalled onboard graphics device

#### ↑ Reset Configuration Data [Disabled]

The **Reset Configuration Data** option allows you to reset the Extended System Configuration Data (ESCD) when you exit setup if you have problems booting the system up after you have installed a new add-on.

↑ **Disabled** (DEFAULT) ESCD will not be reconfigured

↑ **Enabled** ESCD will be reconfigured after you exit setup

### ↑ **Resources Controlled By [Auto (ESCD)]**

The **Resources Controlled By** option gives you the option of manually configuring all the boot and plug and play devices, or allowing BIOS to configure these devices automatically. If you allow BIOS to configure it automatically you will not be able to select the IRQs, DMA and memory base address fields because BIOS will automatically assign them.

↑ **Auto(ESCD)** (DEFAULT) BIOS automatically configures plug and play devices as well as boot devices.

↑ **Manual** You manually configure the plug and play devices and any other boot devices

### ↑ **x IRQ Resources [Press Enter]**

If you select manual in the **Resources Controlled By** option then you will be able to configure the **IRQ Resources**. To do this, select **IRQ Resources** and press **ENTER**. A new menu will appear. (See **BIOS Menu 15**)





### BIOS Menu 15: IRQ Resources

The menu will have the following 12 BIOS configuration options:

- „ IRQ-3 assigned to
- „ IRQ-4 assigned to
- „ IRQ-5 assigned to
- „ IRQ-6 assigned to
- „ IRQ-7 assigned to
- „ IRQ-8 assigned to
- „ IRQ-9 assigned to
- „ IRQ-10 assigned to
- „ IRQ-11 assigned to
- „ IRQ-12 assigned to
- „ IRQ-13 assigned to
- „ IRQ-14 assigned to
- „ IRQ-15 assigned to

The above options all have the same default and the same options. These are listed below.

 **PCI Device** (DEFAULT) The IRQ is assigned to legacy ISA for devices compliant with the original PC AT bus specification, PCI/ISA PNP for devices compliant with the Plug and Play standard whether designed for PCI or ISA bus architecture.

 **Reserved** The IRQ is reserved by BIOS

### **PCI/VGA Palette Snoop [Disabled]**

The **PCI/VGA Palette Snoop** option allows you determine whether or not some special VGA cards, high-end hardware MPEG decoders and other similar devices are allowed to look at the VGA palette on the video card so these devices can determine what colors are in use. This option is only very rarely needed. It should be left at "Disabled" unless a video device specifically requires the setting enabled upon installation.

 **Disabled** (DEFAULT) Does not allow the graphics devices to examine the VGA palette on the graphics card

 **Enabled** Does allow the graphics devices to examine the VGA palette on the graphics card

### **INT Pin # Assignment [Auto]**

The **INT Pin # Assignment** allows you to customize the IRQs for the specified devices assigned to the **INT Pin #**. IRQs for the following **INT Pin #** can be assigned.

- „ INT Pin 1 Assignment
- „ INT Pin 2 Assignment
- „ INT Pin 3 Assignment
- „ INT Pin 4 Assignment
- „ INT Pin 5 Assignment
- „ INT Pin 6 Assignment
- „ INT Pin 7 Assignment

„ INT Pin 8 Assignment

Each **INT Pin # Assignment** has the following configuration options:







„ Auto (Default)  
 „ 3  
 „ 4  
 „ 5  
 „ 6  
 „ 7  
 „ 10  
 „ 11  
 „ 12  
 „ 14  
 „ 15

When any **INT Pin # Assignment** is selected in the BIOS, the devices using that INT will be shown in the right side window along with the following parameters:

„ Bus  
 „ Dev  
 „ Func

#### **Maximum Payload Size [4096]**

The **Maximum Payload Size** option allows you to set the maximum transaction layout packet (TLP) payload sized for the PCI-E devices.

 <b>128</b>	The maximum TLP payload size is 128 bytes
 <b>256</b>	The maximum TLP payload size is 256 bytes
 <b>512</b>	The maximum TLP payload size is 512 bytes
 <b>1024</b>	The maximum TLP payload size is 1024 bytes
 <b>2048</b>	The maximum TLP payload size is 2048 bytes
 <b>4096</b> (DEFAULT)	The maximum TLP payload size is 4096 bytes

## 5.8 PC Health Status

The **PC Health Status** menu (**BIOS Menu 16**) is a passive menu where you cannot alter any BIOS configurations. This menu shows system operating parameters that are essential to the stable operation of your system.

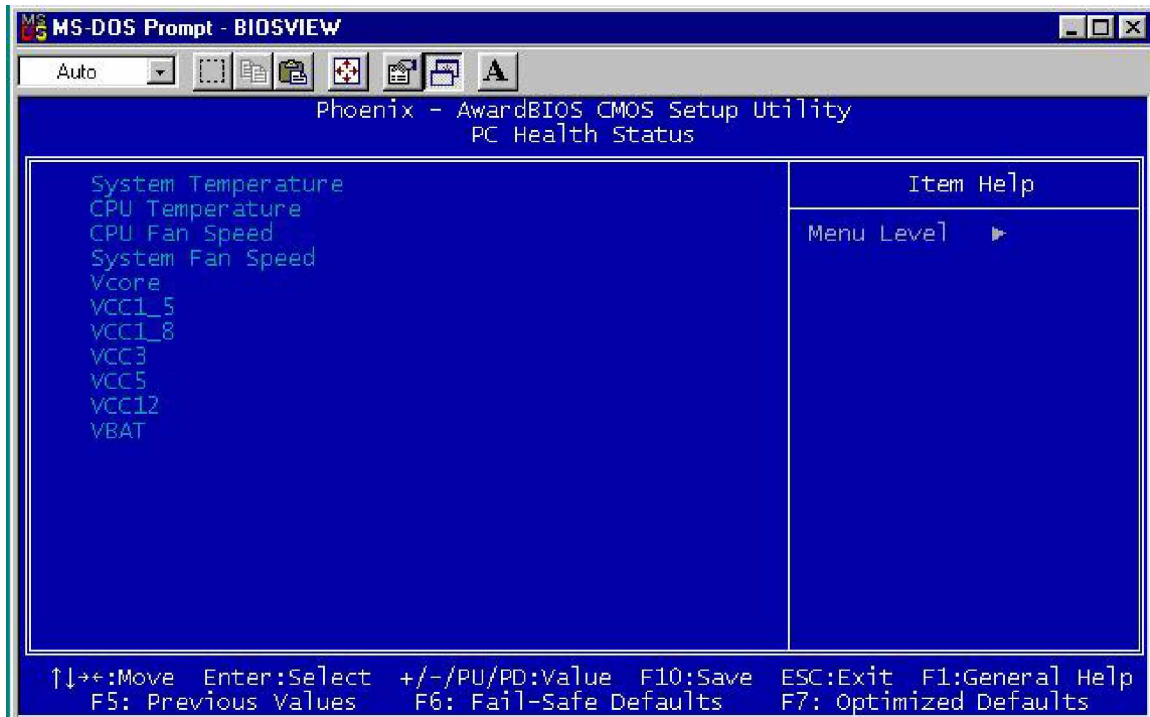

### BIOS Menu 16: PC Health Status

The following system parameters are monitored by the **PC Health Status** menu (**BIOS Menu 16**).

#### 📏 Temperature

The following temperatures are monitored:

- „ System Temperature
- „ CPU Temperature

#### 📏 Fan Speeds

The following fan speeds are monitored:

- „ CPU an Speed
- „ System Fan Speed

### Voltages

The following voltages are monitored

- „ Vcore
- „ VCC1\_5
- „ VCC1\_8
- „ VCC3
- „ VCC5
- „ VCC12
- „ VBAT

**THIS PAGE IS INTENTIONALLY LEFT BLANK**

Chapter

6

# 6 Software Drivers

---

## 6.1 Available Software Drivers

---



### NOTE:

The content of the CD may vary throughout the life cycle of the product and is subject to change without prior notice. You may visit the GAI website or contact technical support for the latest updates.

---

The 3301650 CPU card has six software drivers:

- „ Intel® Chipset Software Installation Utility
- „ Intel® Graphics Media Accelerator
- „ Realtek AC'97 Codec
- „ Marvell Yukon Ethernet Controller
- „ Sil3132 SATALink Controller Driver
- „ Intel® Matrix Storage Manager

All six drivers can be found on the CD that came with the CPU card. To install the first four of the above listed drivers please follow the instructions in the sections below

## 6.2 Chipset Driver Installation

To install the chipset driver, please follow the steps below:

**Step 1:** Insert the CD into the system that contains the 3301650 CPU card. Open the CD folder and locate the icon for the **setup** installation file. Once located, use the mouse to move the cursor over the icon and double click the mouse button.

**Step 2:** Once you double click the **setup** icon, a welcome screen shown in **Figure 6-1** appears.



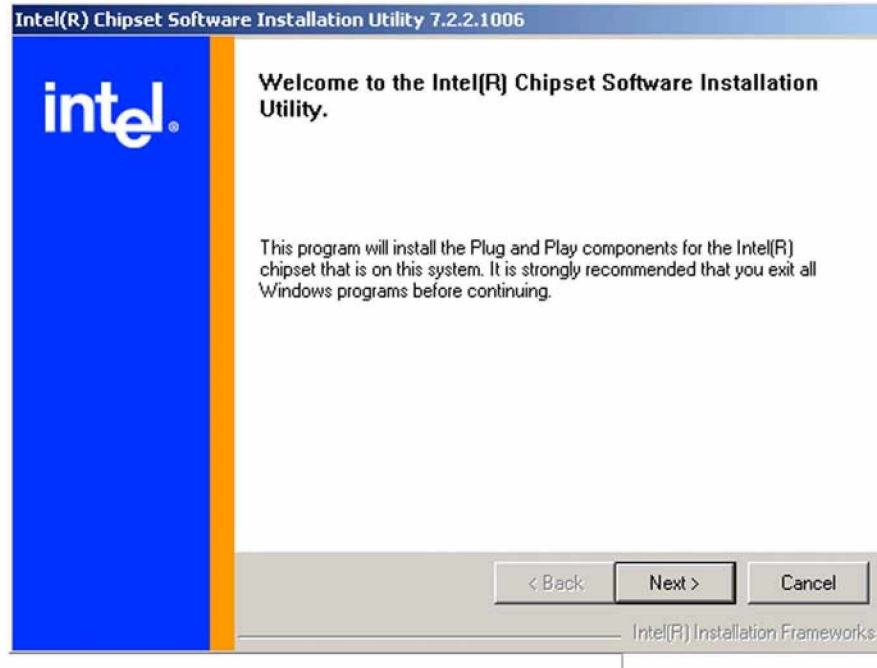

**Figure 6-1: Chipset Driver Installation Welcome Screen**

**Step 3:** After the welcome screen shown in **Figure 6-1** appears, to continue the installation process click the “**NEXT**” button. The license agreement shown in **Figure 6-2** will appear.



**Figure 6-2: Chipset Driver Installation License Agreement**

- Step 4:** Read through the license agreement in **Figure 6-2**. If you choose to accept the terms and conditions stipulated in the agreement then click the “**Yes**” button. The Readme file information shown in **Figure 6-3** will appear.

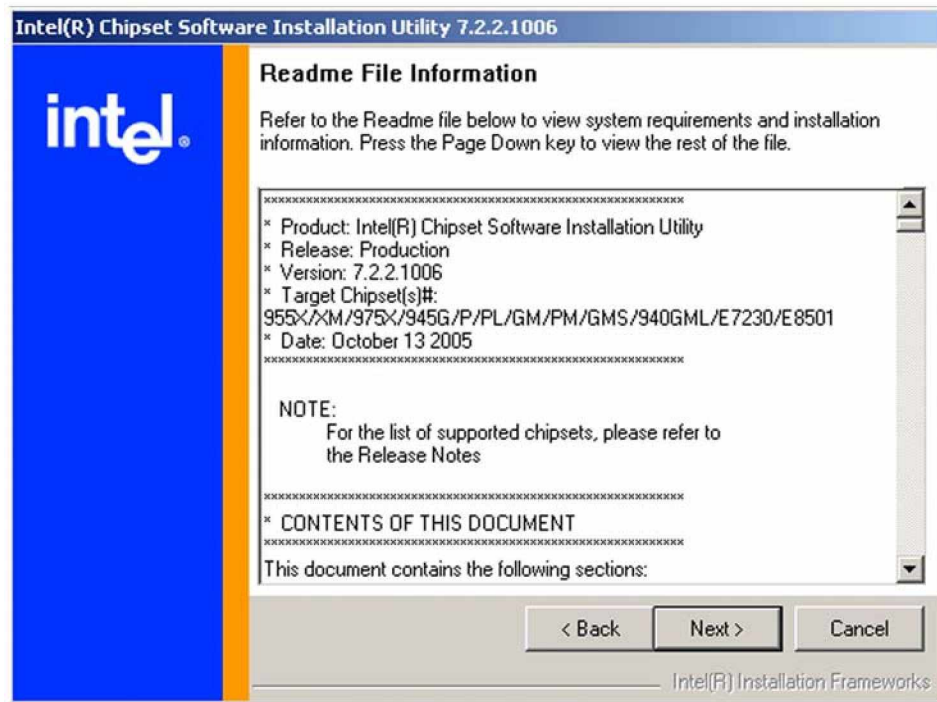

**Figure 6-3: Chipset Driver Readme File Information**

- Step 5:** After reading through the Readme file information shown in **Figure 6-3** click on the "NEXT" button and the chipset driver will be installed.
- Step 6:** After the driver installation process is complete, a confirmation screen shown in **Figure 6-4** will appear. Step 0:

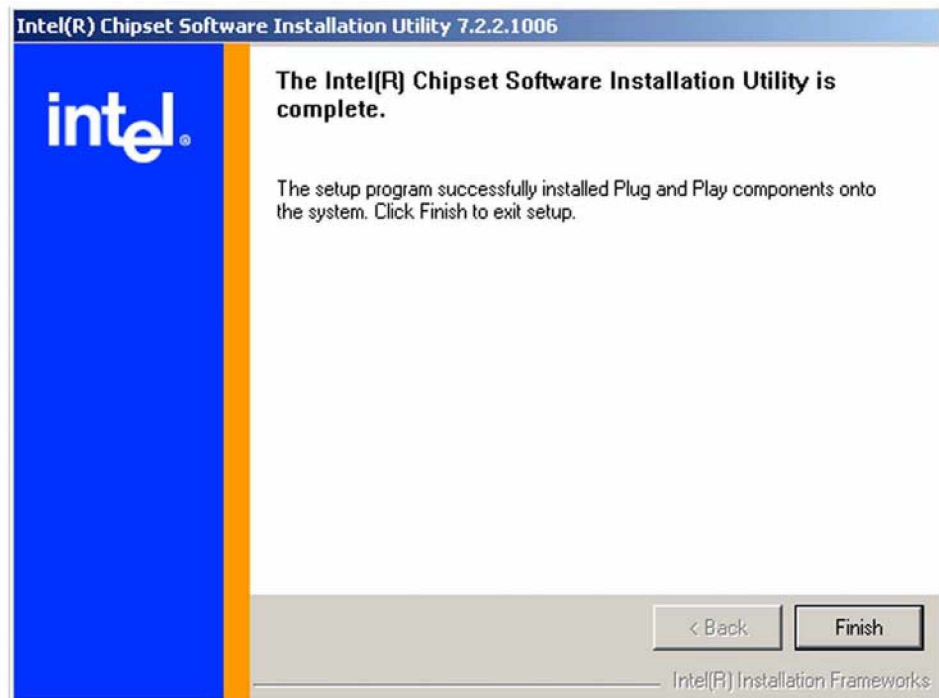
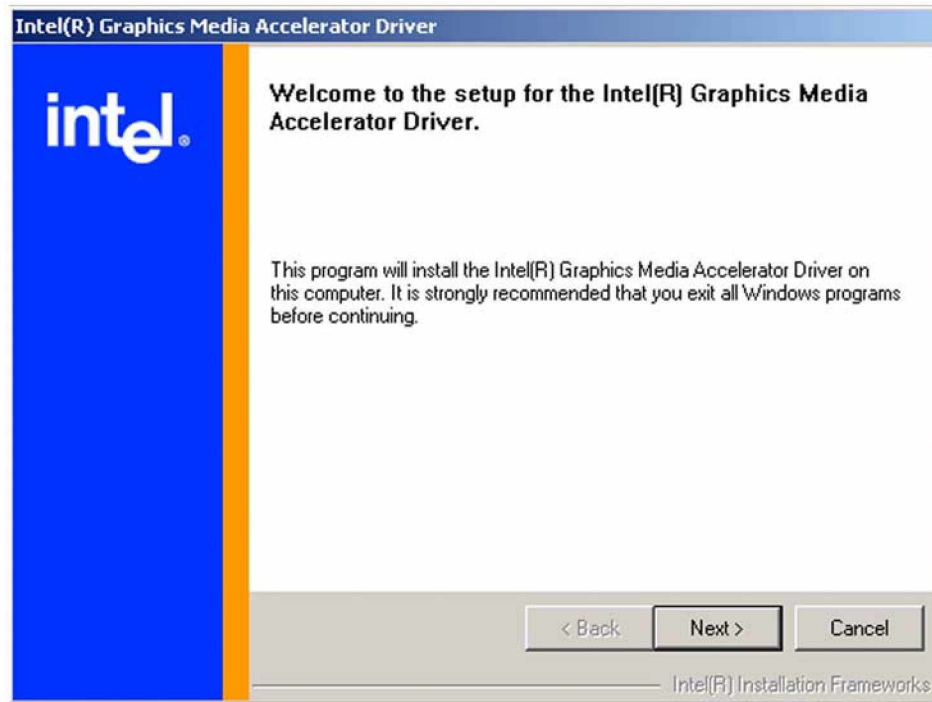

Figure 6-4: Chipset Driver Installation Complete

### 6.3 Intel Graphics Media Accelerator Driver

To install the GMA driver, please follow the steps below:

- Step 1:** Insert the CD into the system that contains the 3301650 CPU card. Open the CD folder and locate the icon for the **Setup** installation file. Once located, use the mouse to move the cursor over the icon and double click the mouse button.
- Step 2:** Once you double click the **Setup** icon, a **Welcome** screen shown in **Figure 6-6** will appear.



**Figure 6-5: GMA Driver Installation Welcome Screen**

**Step 3:** To continue installing click "**Next**" and a license agreement shown in **Figure 6-6** will appear. Read through the license agreement.

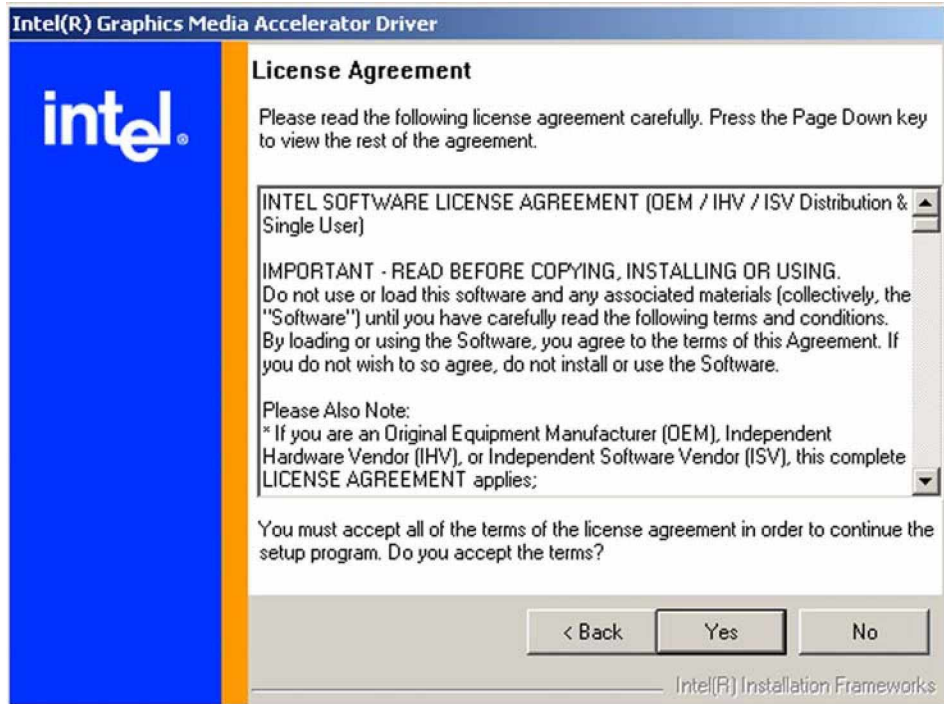

**Figure 6-6: GMA Driver License Agreement**

**Step 4:** If you choose to accept the terms and conditions stipulated in the license agreement shown **Figure 6-6**, click the “**Yes**” button. The installation notice shown in **Figure 6-7** will appear.



**Figure 6-7: GMA Driver Installing Notice**

**Step 5:** After the driver installation process is complete, a confirmation screen shown in **Figure 6-8** will appear.

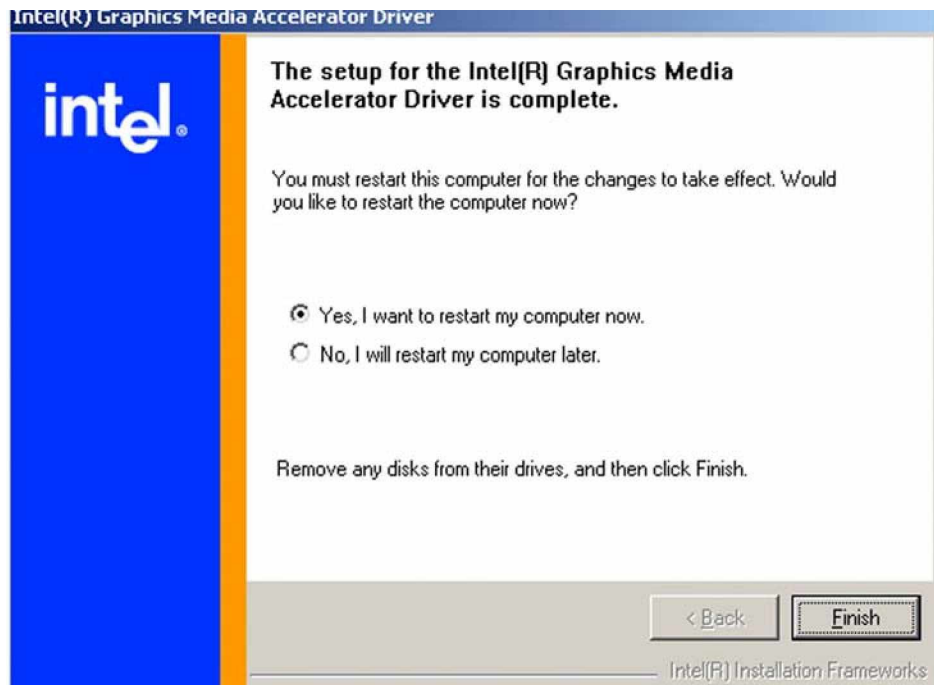

**Figure 6-8: GMA Driver Installation Complete**

**Step 6:** The confirmation screen shown in **Figure 6-8** allows you to restart the computer immediately after the installation is complete or to restart the computer later. For the settings to take effect the computer must be restarted. Once you have decided when to restart the computer, click the “**FINISH**” button. Step 0:

## 6.4 RealTek Audio Driver Installation

To install the RealTek AC'97 Audio driver, please follow the steps below:

**Step 1:** Insert the CD into the system that contains the 3301650 CPU card. Open the CD folder and locate the **AUDIO DRIVER A3.79** directory. Open the directory and look for icon for the **setup.exe** installation file. Once located, use the mouse to move the cursor over the icon and double click the mouse button.

**Step 2:** Once you double click the **Setup** icon, the install shield wizard for the audio driver starts. See **Figure 6-9**.



**Figure 6-9: Audio Driver Install Shield Wizard Starting**

**Step 3:** The RealTek Audio Setup prepares the install shield to guide you through the rest of the setup process. See **Figure 6-10**.

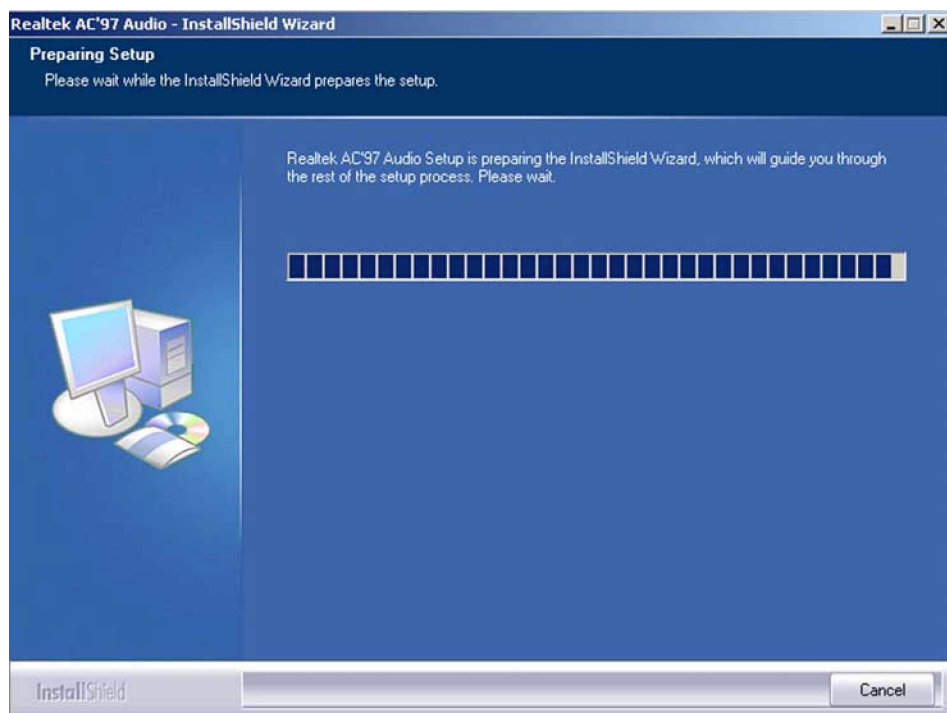

**Figure 6-10: Audio Driver Setup Preparation**

**Step 4:** After install shield is prepared, the welcome screen shown in **Figure 6-11** appears. To continue the installation process, click the **"NEXT"** button. The install shield starts to configure the new software as shown in **Figure 6-12**.



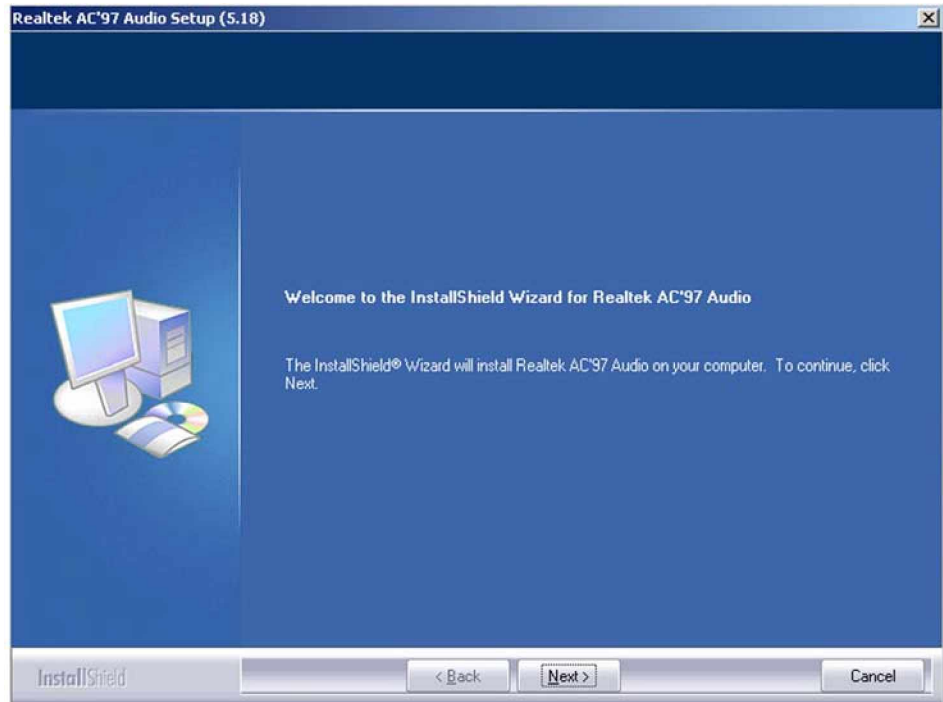

Figure 6-11: Audio Driver Welcome Screen

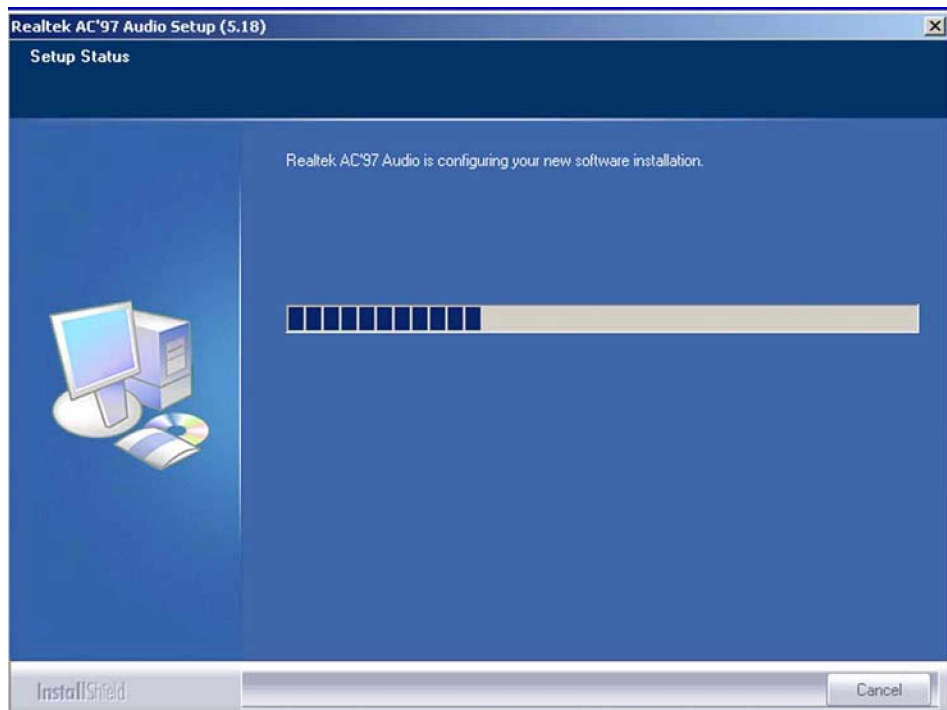

Figure 6-12: Audio Driver Software Configuration

**Step 5:** At this stage the “Digital Signal Not Found” screen shown in Figure 6-13

appears. To continue the installation process, click the “YES” button. The installation notice shown in **Figure 6-7** will appear.



**Figure 6-13: Audio Driver Digital Signal**

**Step 6:** At this stage the clicking the “YES” button in **Figure 6-13** appears, the installation of the driver begins. See **Figure 6-14**.

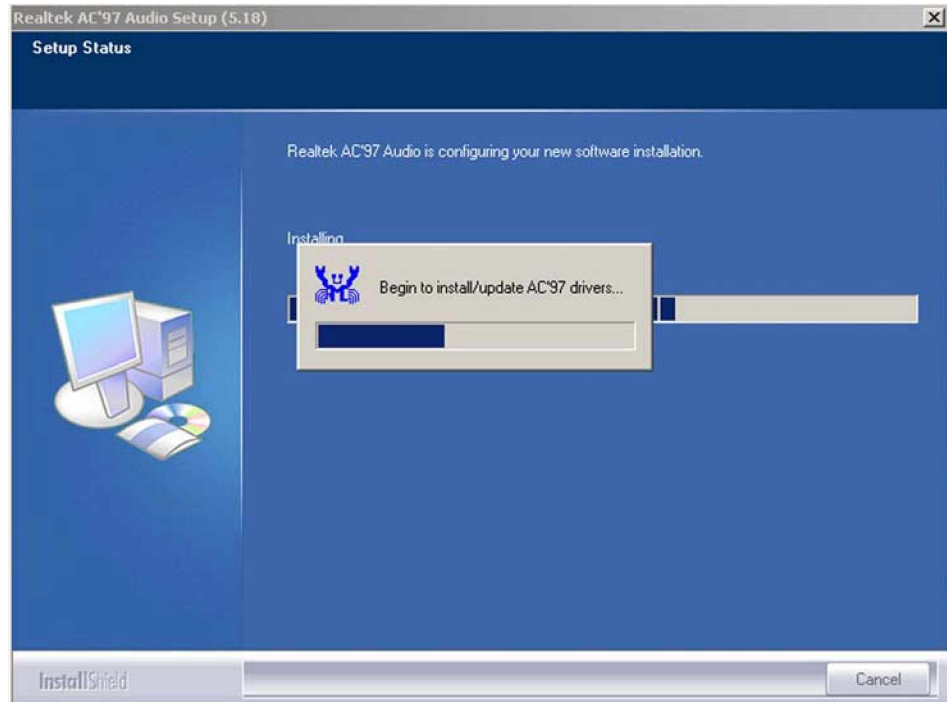

**Figure 6-14: Audio Driver Installation Begins**

**Step 7:** After the driver installation process is complete, a confirmation screen shown in **Figure 6-15** appears

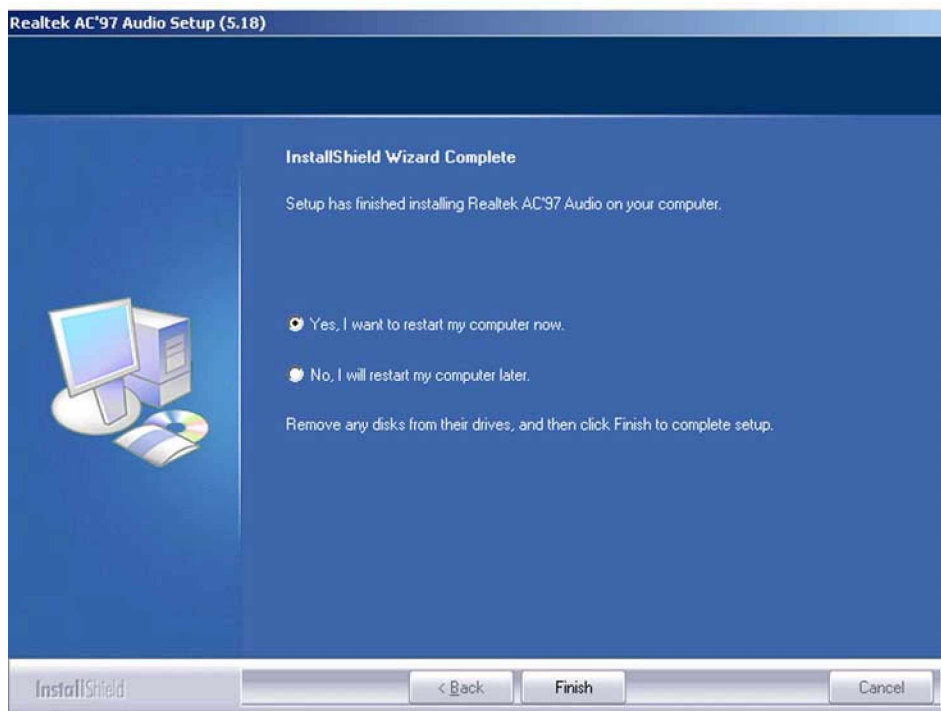

**Figure 6-15: Audio Driver Installation Complete**

**Step 8:** The confirmation screen shown in **Figure 6-15** allows you to restart the computer immediately after the installation is complete or to restart the computer later. For the settings to take effect the computer must be restarted. Once you have decided when to restart the computer, click the “**FINISH**” button. Step 0:

## 6.5 Marvell Gigabit Ethernet Controller Driver Installation

To install the Marvell Gigabit Ethernet controller driver, please follow the steps below:

**Step 1:** Insert the CD into the system that contains the 3301650 CPU card. Open the CD folder and locate the **Mavell 88E8053 Driver \_V84923** directory. Open the directory and look for icon for the **SetupYukonWin.exe** installation file. Once located, use the mouse to move the cursor over the icon and double click the mouse button.

**Step 2:** Once you double click the **SetupYukonWin.exe** icon, the install shield wizard

for the driver is prepared. See **Figure 6-16**.

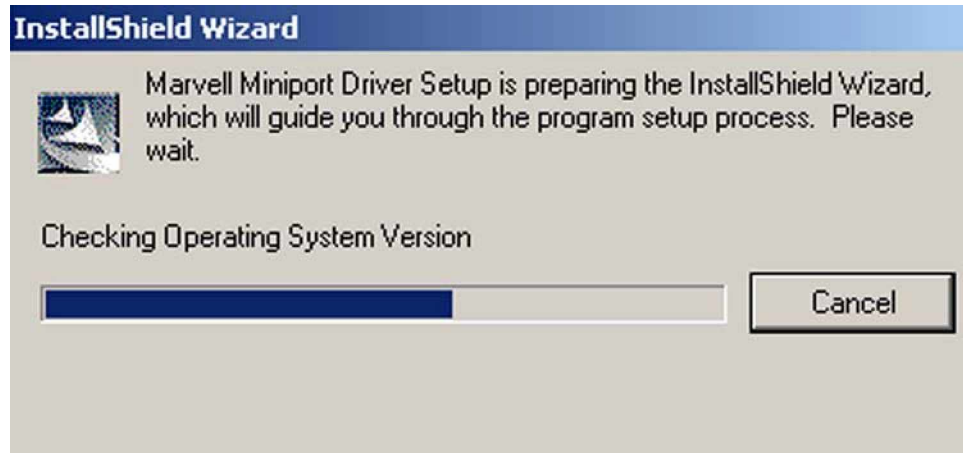

**Figure 6-16: Ethernet Controller Driver Install Shield Wizard Starting**

**Step 3:** After install shield is prepared, the welcome screen shown in **Figure 6-17** appears. To continue the installation process, click the “NEXT” button. The license agreement shown in **Figure 6-18** appears.



**Figure 6-17: Ethernet Controller Driver Installation Welcome Screen**

**Step 4:** To continue the installation process, read through the license agreement in **Figure 6-18**, select **“I accept the terms in the license agreement”** click the **“NEXT”** button.



**Figure 6-18: Ethernet Driver License Agreement**

**Step 5:** After clicking the **“NEXT”** button in **Figure 6-18**, the driver is ready to be installed. See **Figure 6-19**.

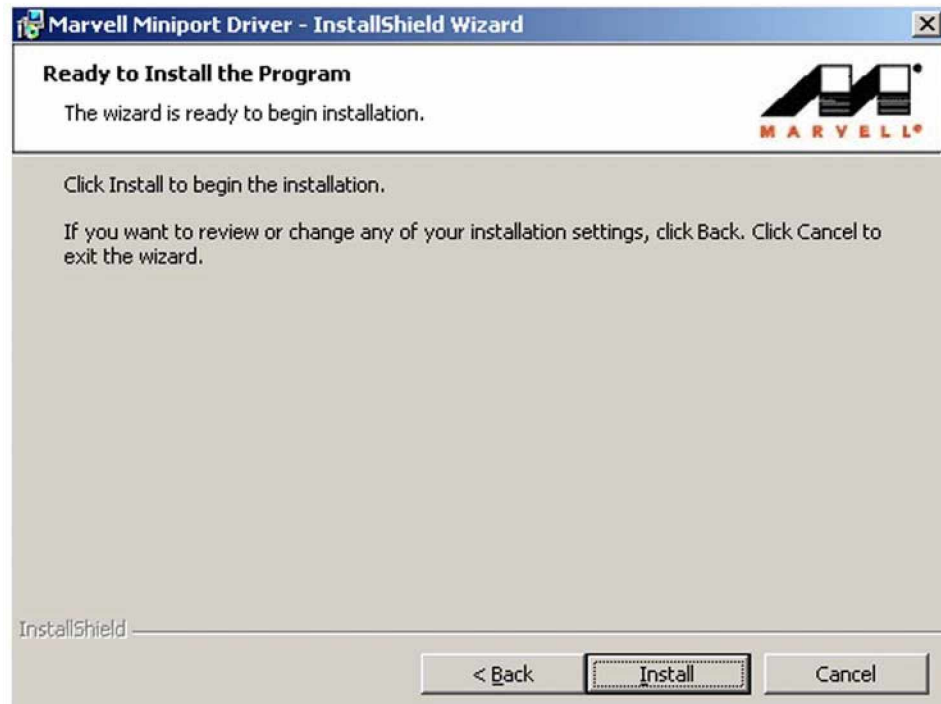

**Figure 6-19: GMA Driver Installing Notice**

**Step 6:** To continue the installation process, click “INSTALL” in **Figure 6-19** and the installation shield begins to install the Ethernet driver. See **Figure 6-20**.

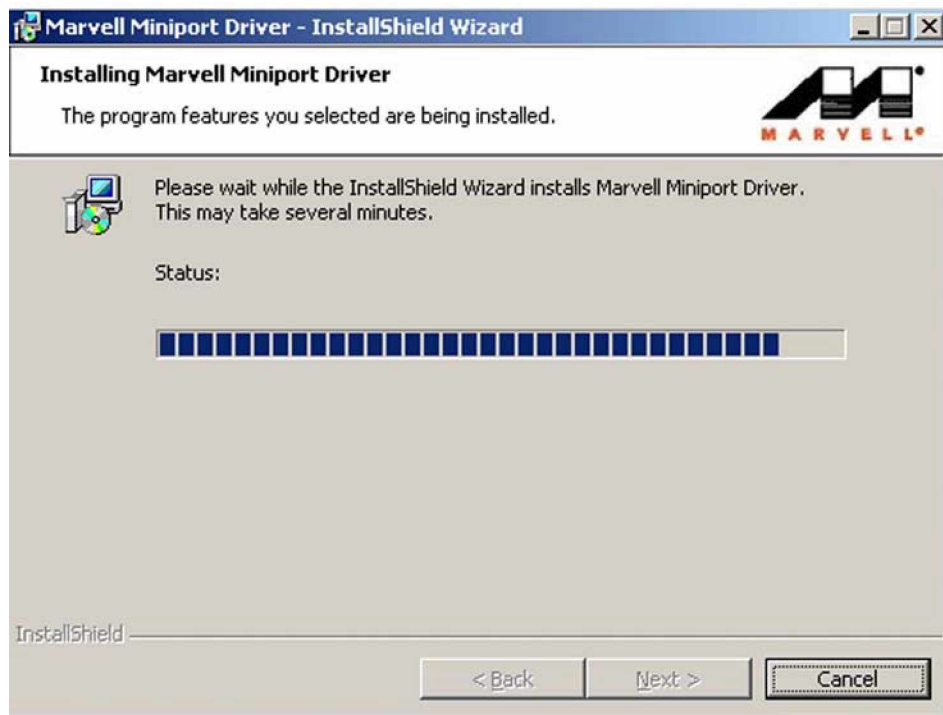

**Figure 6-20: Ethernet Driver is Installed**

**Step 7:** Once the installation is complete and the confirmation screen shown in **Figure 6-21** appears. To exit the shield click the “**FINISH**” button. Step 0:





Figure 6-21: Ethernet Driver Installation Confirmation

**THIS PAGE IS INTENTIONALLY LEFT BLANK**

Appendix

**A**

# **A BIOS Configuration Options**

---

## A.1 BIOS Configuration Options

Below is a list of BIOS configuration options described in **Chapter 5**.

⌈ Load Fail-Safe Defaults .....	89
⌈ Load Optimized Defaults.....	89
⌈ Set Supervisor Password .....	89
⌈ Change User Password.....	89
⌈ Save & Exit Setup .....	89
⌈ Exit Without Saving .....	89
⌈ IDE Master and IDE Slave .....	90
⌈ Drive A [1.44M, 3.5in].....	91
⌈ Video [EGA/VGA].....	91
⌈ EGA .....	91
⌈ VGA .....	91
⌈ SEGA .....	91
⌈ SVGA .....	91
⌈ PG .....	91
⌈ Halt On .....	92
⌈ Base Memory: .....	92
⌈ Extended Memory.....	93
⌈ Total Memory .....	93
⌈ IDE HDD Auto-Detection [Press Enter].....	93
⌈ IDE Channel 0/1 Master/Slave [Auto].....	94
⌈ Access Mode [Auto] .....	94
⌈ Capacity .....	95
⌈ Cylinder .....	95
⌈ Head .....	95
⌈ Precomp .....	95
⌈ Landing Zone .....	95
⌈ Sector .....	95
⌈ Virus Warning [Disabled] .....	97
⌈ CPU L1 & L2 Cache [Enabled].....	98

↑ Quick Power On Self Test [Enabled] .....	98
↑ Boot Device      98	
↑ Boot Other Device [Enabled] .....	99
↑ Boot Up Floppy Seek [Enabled] .....	99
↑ Boot Up Numlock Status [On] .....	99
↑ Typematic Rate Setting [Disabled].....	100
↑ x Typematic Rate (Chars/sec) [6] .....	100
↑ x Typematic Delay (Msec) [250].....	101
↑ Security Option [Setup].....	101
↑ APIC Mode [Enabled] .....	102
↑ MPS Version Control for OS [1.4].....	102
↑ OS Select For DRAM > 64MB [Non-OS2].....	102
↑ Report No FDD For WIN 95 [No] .....	102
↑ Small Logo (EPA) Show [Disabled].....	103
↑ Delay Prior to Thermal [16min].....	103
↑ Thermal Management [Thermal Monitor 1] .....	104
↑ x TM2 Bus Ratio [15 X] .....	105
↑ x TM2 BUS VID [0.860V] .....	105
↑ Execute Disable Bit [Enabled] .....	105
↑ DRAM Latency Timing [By SPD] .....	107
↑ CAS Latency Time [4].....	108
↑ DRAM RAS# to CAS# Delay [4].....	108
↑ DRAM RAS# Precharge [4] .....	108
↑ Precharge dealy (tRAS) [12] .....	109
↑ System Memory Frequency .....	109
↑ SLP_S4# Assertion Width [4 to 5 sec].....	110
↑ System BIOS Cacheable [Enabled].....	110
↑ Video BIOS Cacheable [Disabled].....	110
↑ Memory Hole At 15M – 16M [Disabled].....	110
↑ PCI Express Root Port Func. [Press Enter] .....	111
↑ PEG/Onchip VGA Control [Auto].....	111
↑ On-Chip Frame Buffer Size [8MB] .....	112

⌈ DVMT Mode [DVMT].....	112
⌈ DVMT/FIXED Memory Size [128MB].....	113
⌈ Boot Display [Auto] .....	113
⌈ IDE HDD Block Mode [Enabled] .....	115
⌈ IDE DMA transfer access [Enabled].....	115
⌈ On-Chip Primary PCI IDE [Enabled].....	116
⌈ IDE PIO [Auto] .....	116
⌈ IDE UDMA [Auto].....	116
⌈ On-Chip Secondary PCI IDE [Auto].....	117
⌈ On Chip Serial ATA [Disabled] .....	117
⌈ x PATA IDE Mode [Secondary].....	118
⌈ SATA Port .....	118
⌈ USB Controller [Enabled].....	118
⌈ USB 2.0 Controller [Enabled].....	119
⌈ USB Keyboard Support [Disabled] .....	119
⌈ Azalia/AC97 Audio Select [Auto].....	119
⌈ Onboard LAN1/2 Boot Rom [Enabled].....	120
⌈ Onbd LAN1/2 MacAddress contr [Enabled].....	120
⌈ POWER ON Function [BUTTON ONLY] .....	121
⌈ x KB Power ON Password [Enter].....	122
⌈ x Hot Key Power ON [Ctrl-F1].....	122
⌈ Onboard FDC Controller [Enabled].....	123
⌈ Onboard Serial Port 1 [3F8/IRQ4].....	123
⌈ Onboard Serial Port 2 [3F8/IRQ4].....	123
⌈ UART Mode Select.....	124
⌈ x RxD, TxD Active [Hi,Lo].....	124
⌈ x IR Transmission Delay [Enabled].....	124
⌈ UR2 Duplex Mode [Half] .....	124
⌈ Use IR Pins [IR-Rx2Tx2].....	124
⌈ Parallel Port Mode [SPP].....	125
⌈ x EPP Mode Select.....	125
⌈ x ECP Mode Use DMA [3].....	126

⌈ PWRON After PWR-Fail [Off] .....	126
⌈ Game Port Address [201].....	126
⌈ ACPI Function [Enabled].....	128
⌈ ACPI Suspend Type [S1(POS)].....	128
⌈ Run VGABIOS if S3 Resume [Auto].....	128
⌈ Power Management [User Define].....	129
⌈ Video Off Method [DPMS] .....	129
⌈ Video Off In Suspend [Yes].....	130
⌈ Suspend Type [Stop Grant] .....	130
⌈ MODEM Use IRQ [3].....	130
⌈ Suspend Mode [Disabled].....	131
⌈ HDD Power Down [Disabled] .....	131
⌈ Soft -Off by PWR-BTTN [Instant-Off].....	132
⌈ Wake-Up by PCI Card [Enabled].....	132
⌈ Power On by Ring [Enabled] .....	133
⌈ USB KB Wake-Up From S3 [Disabled].....	133
⌈ Resume by Alarm [Disabled].....	133
⌈ x Date(of Month) Alarm [0].....	134
⌈ x Time(hh:mm:ss) Alarm [0 : 0 : 0].....	134
⌈ Reload Global Timer Events .....	134
⌈ Init Display First [PCI Slot].....	135
⌈ Reset Configuration Data [Disabled] .....	135
⌈ Resources Controlled By [Auto (ESCD)].....	136
⌈ x IRQ Resources [Press Enter].....	136
⌈ PCI/VGA Palette Snoop [Disabled].....	138
⌈ INT Pin # Assignment [Auto] .....	138
⌈ Maximum Payload Size [4096].....	139
⌈ Temperature .....	140
⌈ Fan Speeds .....	140
⌈ Voltages .....	141
⌈ Spread Spectrum .....	Error! Bookmark not defined.

**THIS PAGE IS INTENTIONALLY LEFT BLANK**



Appendix

**B**

# **B Watchdog Timer**

---

**NOTE:**

The following discussion applies to DOS environment. It is recommended you visit our website for specific drivers for more sophisticated operating systems, e.g., Windows and Linux.

The Watchdog Timer is provided to ensure that standalone systems can always recover from catastrophic conditions that cause the CPU to crash. This condition may have occurred by external EMI or a software bug. When the CPU stops working correctly, Watchdog Timer will either perform a hardware reset (cold boot) or a Non-Maskable Interrupt (NMI) to bring the system back to a known state.

A BIOS function call (INT 15H) is used to control the Watchdog Timer:

**INT 15H:**

<b>AH – 6FH Sub-function:</b>	
AL – 2:	Sets the Watchdog Timer's period.
BL:	Time-out value (Its unit-second is dependent on the item "Watchdog Timer unit select" in CMOS setup).

**Table B-1: AH-6FH Sub-function**

You have to call sub-function 2 to set the time-out period of Watchdog Timer first. If the time-out value is not zero, the Watchdog Timer will start counting down. While the timer value reaches zero, the system will reset. To ensure that this reset condition does not occur, calling sub-function 2 must periodically refresh the Watchdog Timer. However, the Watchdog timer will be disabled if you set the time-out value to be zero.

A tolerance of at least 10% must be maintained to avoid unknown routines within the operating system (DOS), such as disk I/O that can be very time-consuming.

**NOTE:**

When exiting a program it is necessary to disable the Watchdog Timer, otherwise the system will reset.

Example program:

```

; INITIAL TIMER PERIOD COUNTER
;
W_LOOP:

    MOV     AX, 6F02H      ;setting the time-out value
    MOV     BL, 30        ;time-out value is 48 seconds
    INT     15H

;
; ADD YOUR APPLICATION PROGRAM HERE
;
    CMP     EXIT_AP, 1    ;is your application over?
    JNE     W_LOOP       ;No, restart your application

    MOV     AX, 6F02H    ;disable Watchdog Timer
    MOV     BL, 0        ;
    INT     15H

;
; EXIT ;

```

**THIS PAGE IS INTENTIONALLY LEFT BLANK**

Appendix

C

# C Address Mapping

---

## C.1 IO Address Map

I/O address Range	Description
000-01F	DMA Controller
020-021	Interrupt Controller
040-043	System time
060-06F	Keyboard Controller
070-07F	System CMOS/Real time Clock
080-09F	DMA Controller
0A0-0A1	Interrupt Controller
0C0-0DF	DMA Controller
0F0-0FF	Numeric data processor
1F0-1F7	Primary IDE Channel
2F8-2FF	Serial Port 2 (COM2)
378-37F	Parallel Printer Port 1 (LPT1)
3B0-3BB	Intel(R) 82915 Graphics Controller
3C0-3DF	Intel(R) 82915 Graphics Controller
3F6-3F6	Primary IDE Channel
3F7-3F7	Standard floppy disk controller
3F8-3FF	Serial Port 1 (COM1)

**Table C-1: IO Address Map**

## C.2 1st MB Memory Address Map

Memory address	Description
00000-9FFFF	System memory
A0000-BFFFF	VGA buffer
F0000-FFFFFF	System BIOS
1000000-	Extend BIOS

**Table C-2: 1<sup>st</sup> MB Memory Address Map**

### C.3 IRQ Mapping Table

IRQ0	System Timer	IRQ8	RTC clock
IRQ1	Keyboard	IRQ9	ACPI
IRQ2	Available	IRQ10	LAN
IRQ3	COM2	IRQ11	LAN/USB2.0/SATA
IRQ4	COM1	IRQ12	PS/2 mouse
IRQ5	SMBus Controller	IRQ13	FPU
IRQ6	FDC	IRQ14	Primary IDE
IRQ7	Available	IRQ15	Secondary IDE

Table C-3: IRQ Mapping Table

### C.4 DMA Channel Assignments

Channel	Function
0	Available
1	Available
2	Floppy disk (8-bit transfer)
3	Available
4	Cascade for DMA controller 1
5	Available
6	Available
7	Available

Table C-4: IRQ Mapping Table

**THIS PAGE IS INTENTIONALLY LEFT BLANK**



Appendix

**D**

# **D External AC'97 Audio CODEC**

---

### D.1 Introduction

The audio functionalities of the 3301650 CPU card can be implemented using a separately purchased audio module, the AC-KIT08R-R10. The audio kit is powered by a Realtek ALC655 is a 16-bit, full duplex AC'97 2.3 compatible audio CODEC with 48KHz sampling rate. The audio kit functionalities are interfaced through three (3) phone jack connectors and two (2) pin headers including:

1. A LINE input shared with surround output
2. A MIC input shared with Center and LFE output
3. A LINE output
4. Analog line-level stereo inputs with 5-bit volume control: CDIN1 and AUXIN1.

Both Front\_out and Surround\_out are equipped with a built-in 50mW/20ohm amplifier. The ALC655 supports host/soft audio from Intel ICHx chipsets as well as audio controller based VIA/SIS/Ali/ATI chipset with bundled Windows series drivers (XP/ME/2000/98/NT), EAX/Direct Sound 3D/I3DL2/A3D compatible sound effect utilities supporting Karaoke, 26 kinds of environment sound emulations with 10-band equalizer, and HRTF 3D positional audio. The audio kit provides an excellent entertainment package sufficient for today's multimedia systems.

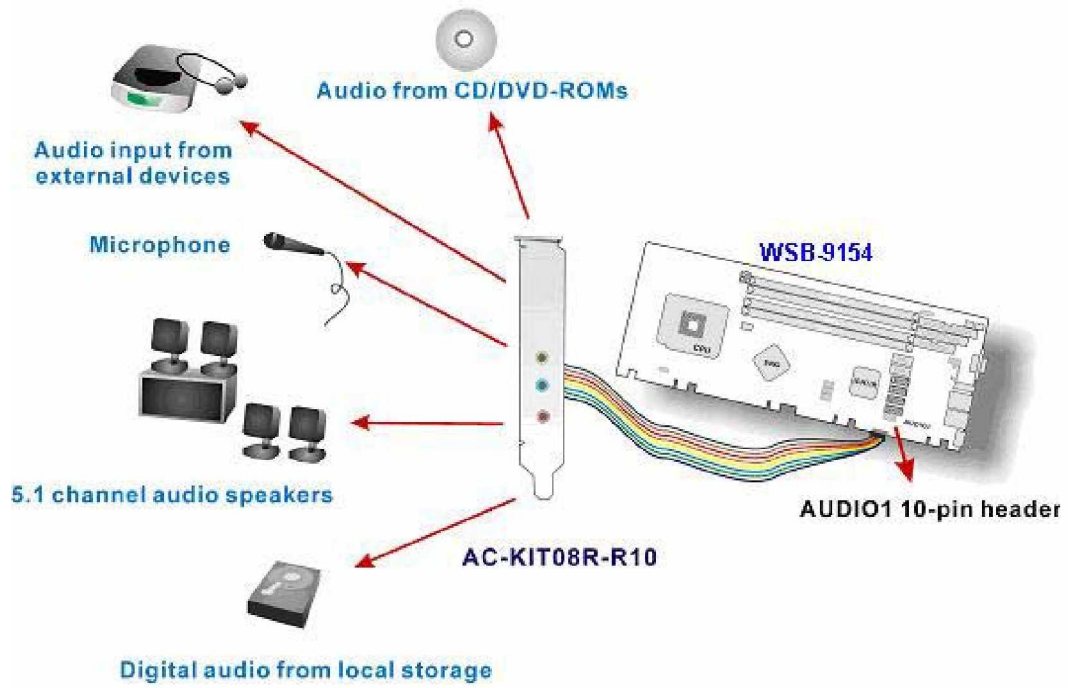

Figure D-1: Audio Functionalities via the Audio Kit

## D.2 Physical Connection

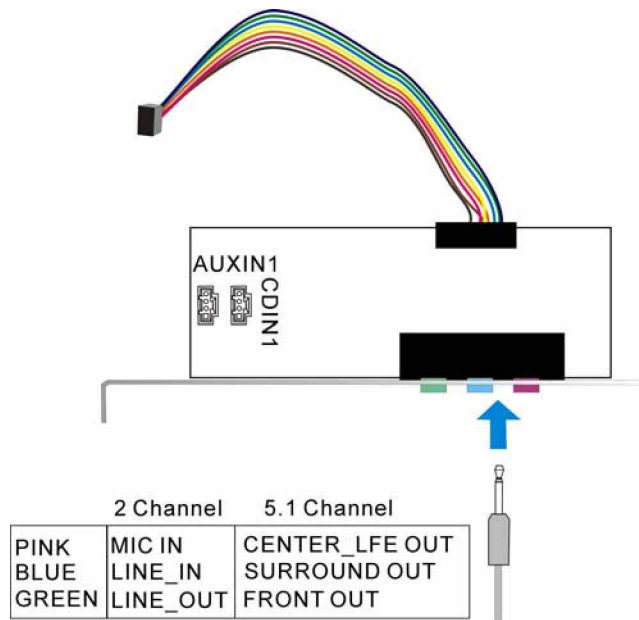

Figure D-2: Audio Kit Connectors

The audio kit comes with a PCI slot bracket for the installation into a PC case or rackmount chassis. Connect the 10-pin header to the PCIE-9450's AUDIO1 header as shown in Figure E-1, and if necessary, connect the CDIN1 and AUXIN1 to optical drives or other audio sources, e.g., an MPEG card, using a 4-pin cable. Note that depending on the devices you connect to, the phone jacks have different functions with different audio installation modes (2 channel or 5.1 channel modes).

## D.3 Driver Installation

The driver installation has been described in **Chapter 6, Section 6.4**.

After reboot, you should be able to find the sound effect configuration utility in Windows Control Panel (see **Figure D-3**); and if peripheral speakers have been properly connected, hear the sound effects.

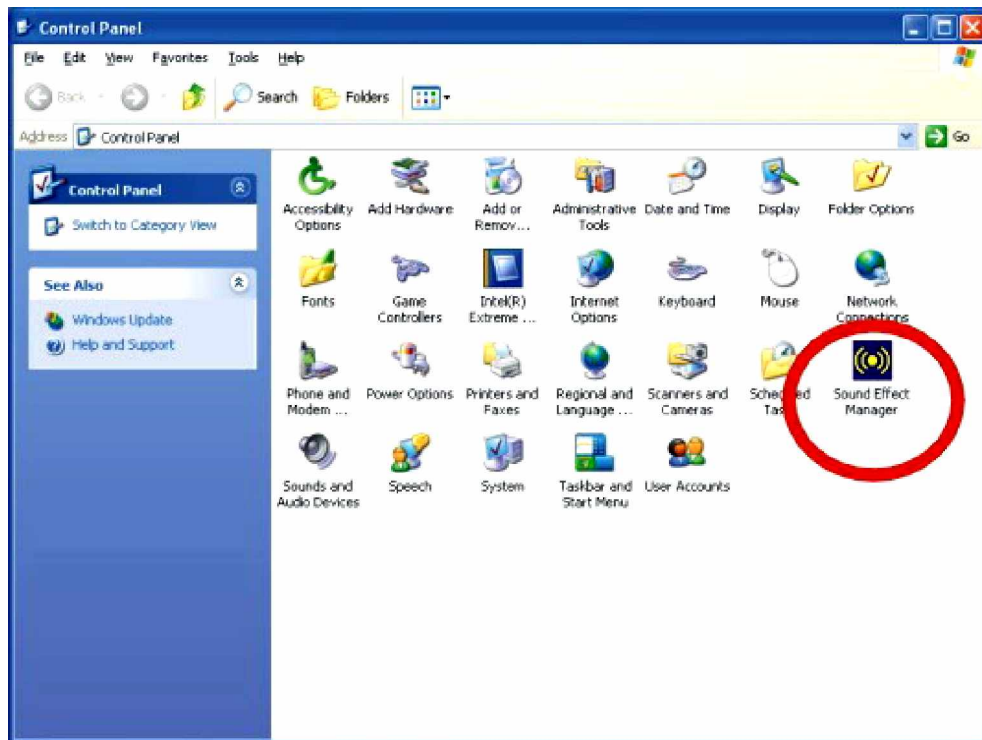

**Figure D-3: Sound Effect Manager Icon**

## D.4 Sound Effect Configuration

After installing the audio CODEC driver, you should be able to use the multi-channel audio features now. Click the audio icon from the Notification Area from system task bar (see **Figure D-5**). The shortcut to the configuration utility is also available through the **Sound Effect Manager** icon in the **Control Panel** (**Figure D-4**).

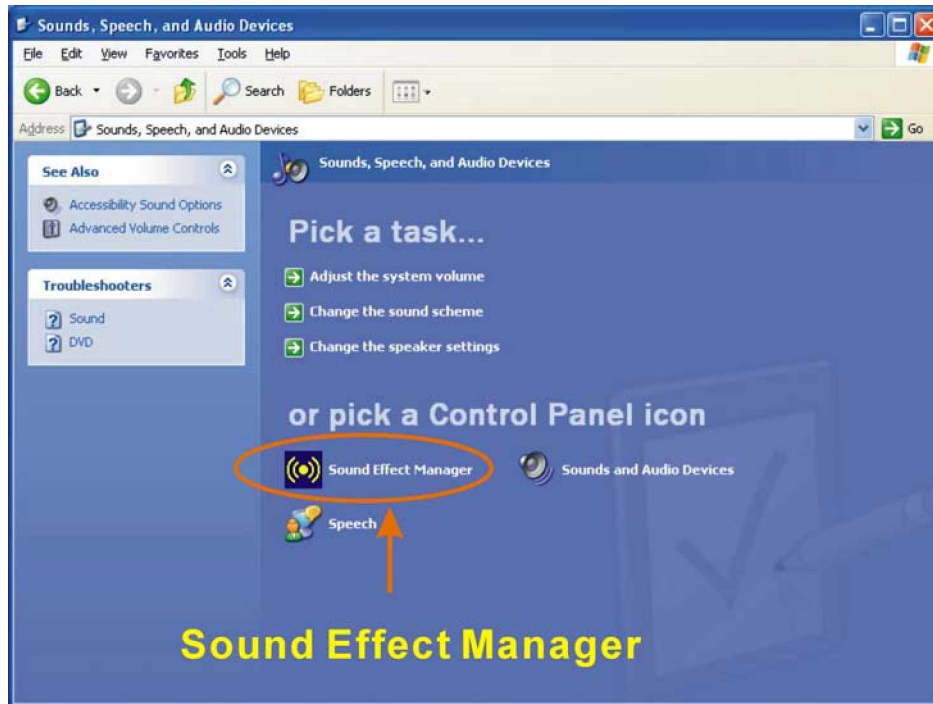

Figure D-4: Sound Effect Manager Icon [Control Panel]



Figure D-5: Sound Effect Manager Icon [Task Bar]

## D.5 Sound Effect

You may select a pre-configured sound environment setting with the preset equalizer settings. You may also load an equalizer setting or make a new equalizer setting using the “**Load EQ Setting**” and “**Save Preset**” button. (See **Figure D-7**)

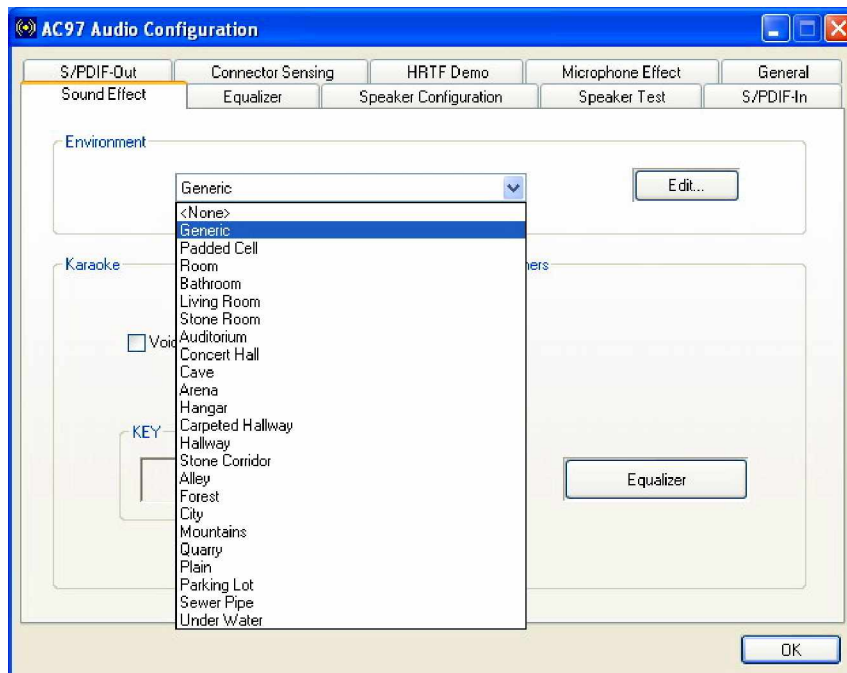

**Figure D-6: Setting Sound Effects**

## D.6 Environment Simulation

This is the default screen whenever the configuration utility is opened.

You may select different sound environment modes by a single click on the Environment pull-down list. There are a total of 23 preset environment modes (see **Figure D-7**). You may also fine-tune the environment setting by clicking the **Edit** button on the right, which displays an editor window. Select a preset mode you want to edit. Select a preset mode, and then select one the property value from the list below by a single click. Use the scroll bar below to adjust properties setting. When the adjustment is done, click the Save button to proceed.

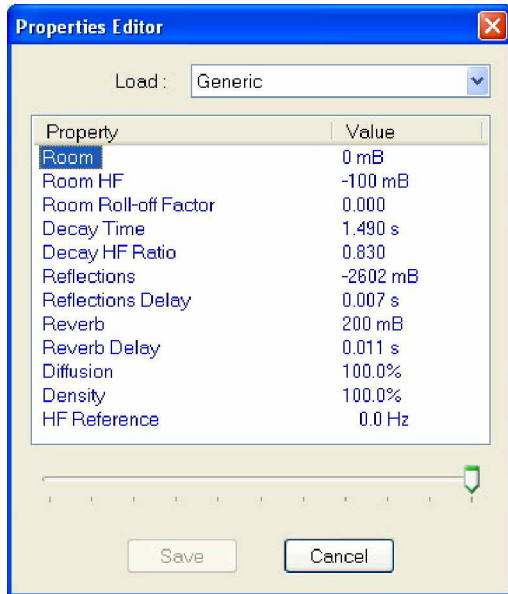

Figure D-7: Sound Effects Properties Editor

## D.7 Karaoke Mode

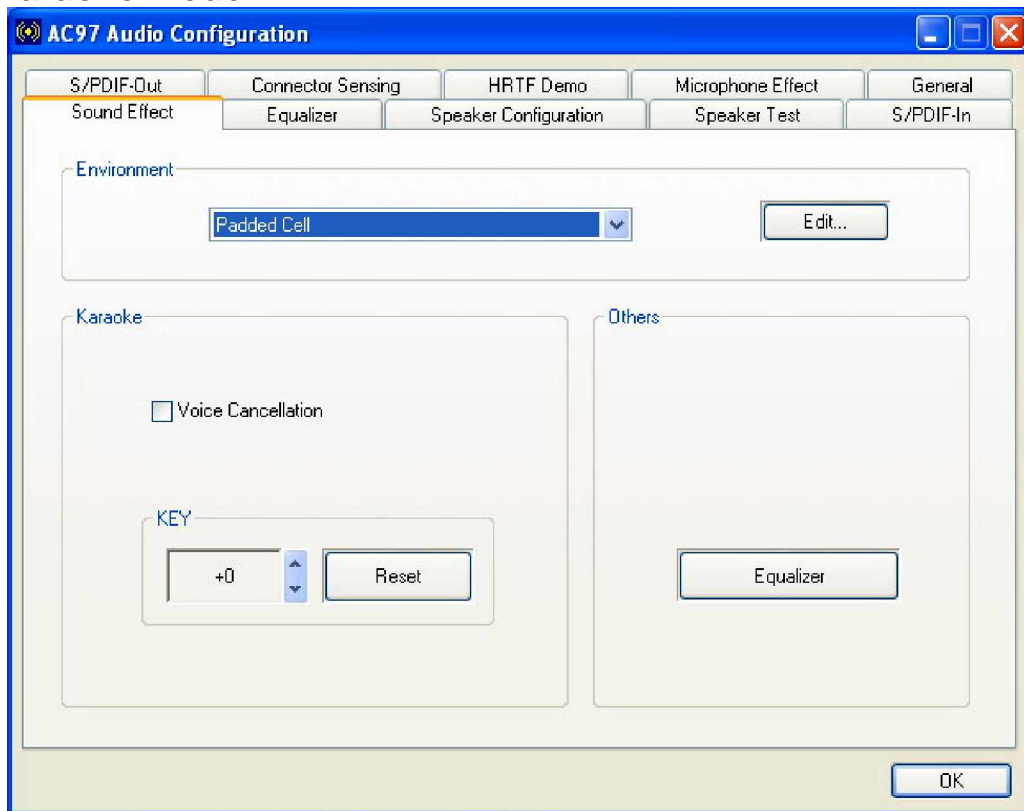

Figure D-8: Karaoke Mode

The Karaoke mode shown in **Figure D-8** allows you to eliminate the vocal of the music you play or adjust the key to accommodate your range.

The configuration options that come with the Karaoke function include:

1. **Voice Cancellation:** This checkbox, when selected, disables the vocal part of the music you play in your computer while the background music remains.
2. **Key adjustment:** Use the Up or Down arrow icons to find a key that fits your vocal range.



### NOTE:

The Equalizer button on the default display brings you to the same configuration window as the Equalizer function tab on top of the window.

## D.8 Equalizer Selection

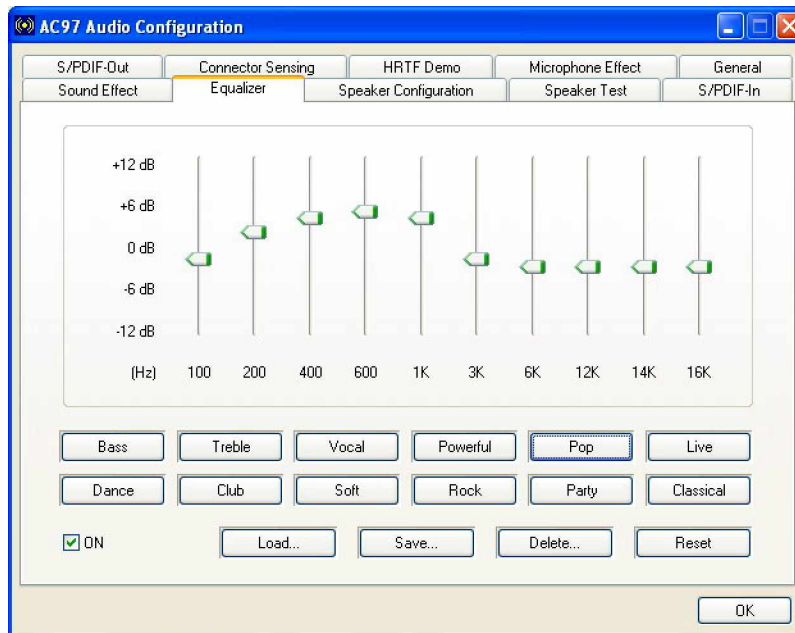
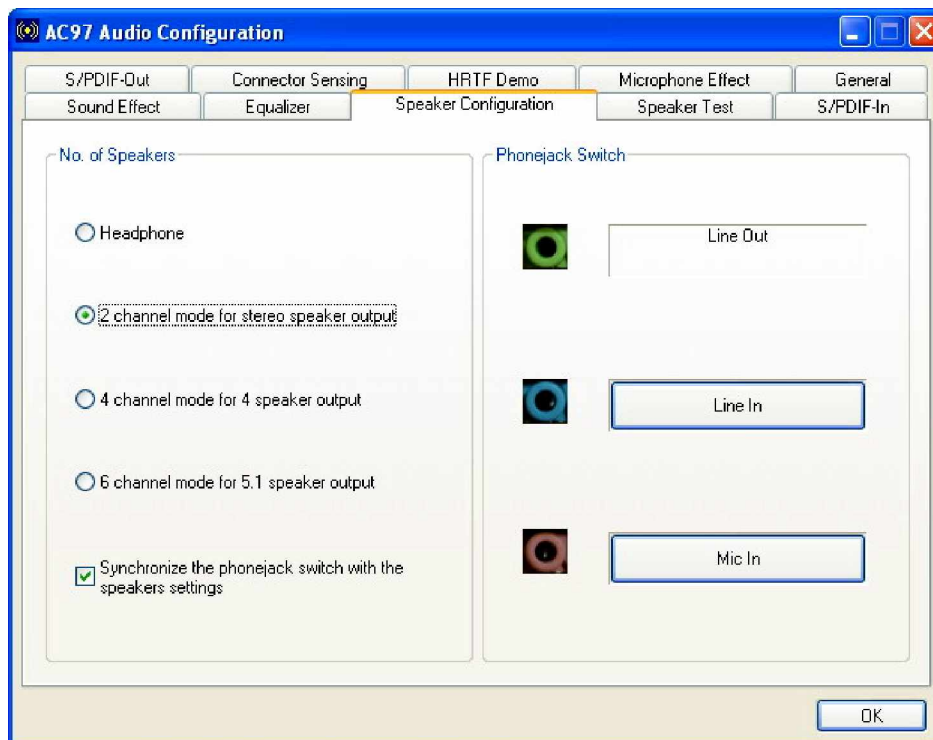

**Figure D-9: Equalizer Settings**



The equalizer in **Figure D-9** allows users to change sound effect parameters. The default screen shows equalized values. You may also select preset modes from the buttons below. The configurable values include 10 bands of equalizer ranging from 100Hz to 16KHz. Use the scroll bar to fine-tune, and use the **Load**, **Save**, **Delete**, and **Reset** buttons to edit your settings.

## D.9 Speaker Configuration



**Figure D-10: Speaker Configuration**

In this functional window, you can configure your multi-channel speaker settings.

Select the audio configuration from the **No. of Speakers** section on the left by clicking on one of the check circles.

The configurable options are:

1. Headphone

2. Channel mode for stereo speaker output
3. Channel mode for 4 speaker output
4. Channel mode for 5.1 speaker output
5. Synchronize the phonejack switch with speakers settings

Select a speaker configuration by selecting its check circle, and then click **OK** to apply the configuration change.

Connect your speakers to the corresponding phonejacks. It is recommended you write down your configuration, power off the system, and then complete the physical connections.

Select from the **Phonejack Switch** section if you want to re-define the phonejacks. Click the specific phonejack button for several times to change its input/output functionality.

### D.10 Speaker Test

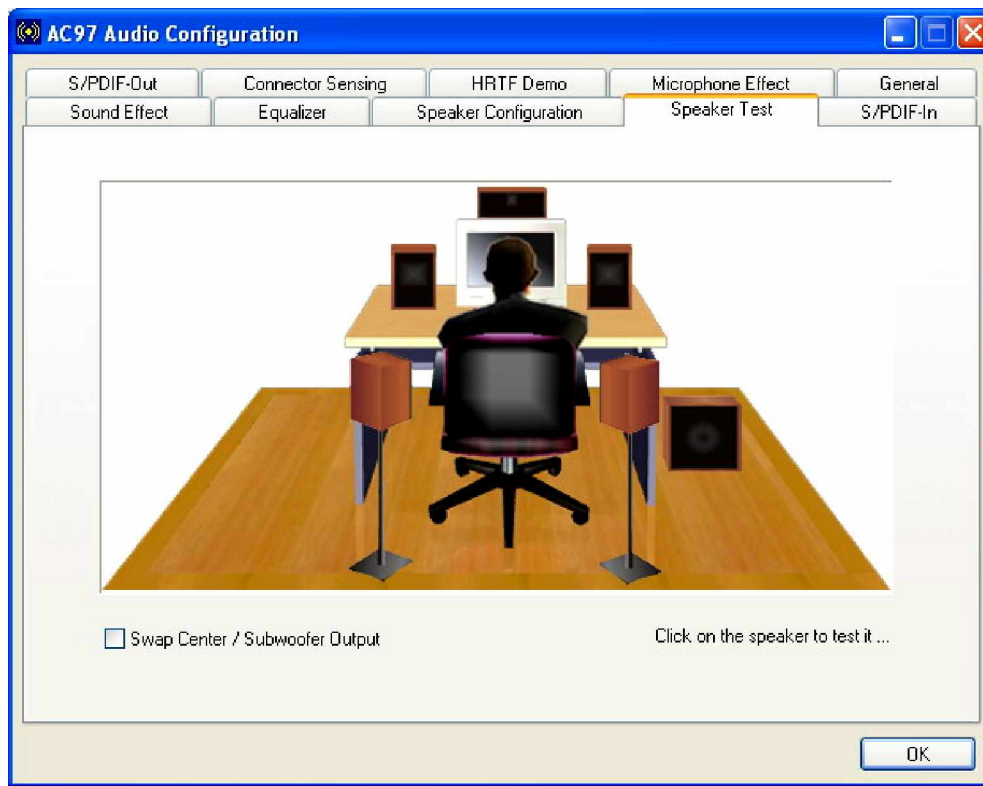

Figure D-11: Audio Configuration

The audio configuration window in **Figure D-11** allows you to test each connected speaker to see if your 4-channel or 6-channel audio operates properly. If any speaker malfunctions, you should then check the cabling or replace the malfunctioning parts.

Select each specific speaker to test its functionality. The speaker you select will be highlighted and sound should be generated.



**NOTE:**

1. The test scenario that appears in the **Speaker Test** window corresponds to the number of speakers you selected in the **Sound Effect** window.
  2. You should select and deselect the **Swap Center/Subwoofer Output** check box to see if these two devices properly work.
- 

### D.11 S/PDIF-In & S/PDIF-Out

**These functions are currently not supported.**

## D.12 Connector Sensing

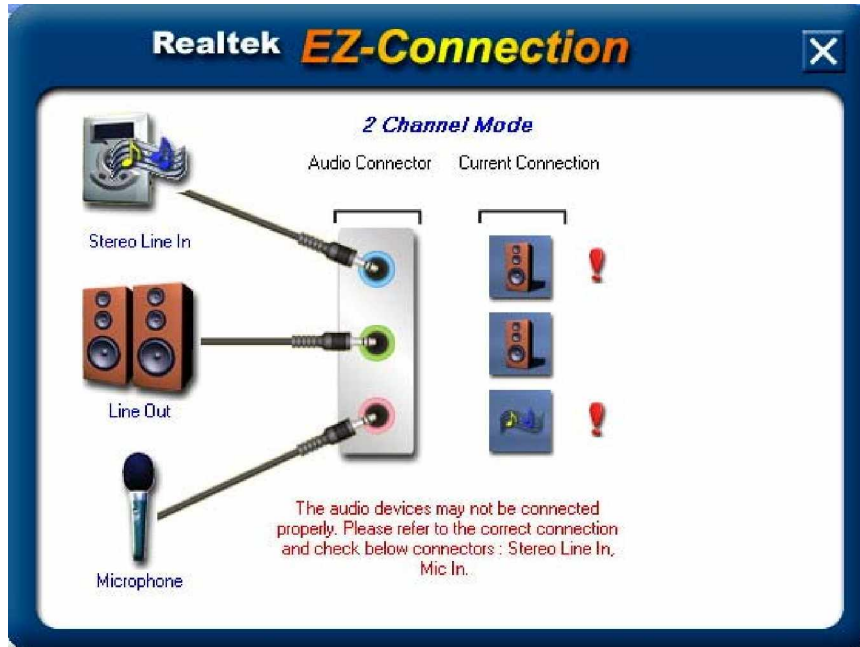

**Figure D-12: Connector Sensing**

Realtek ALC655 supports Jack Sensing functionality. If an audio device is plugged into the wrong connector, a warning message will display informing users to correct the physical connections.

Click the Start button in **Figure D-12** to start the sensing. Please remember to close all running audio-related programs before executing the sensing operation.

The EZ-Connection screen in **Figure D-13** shows the result of sensing test.



**Figure D-13: EX Connection**

The "Audio Connector" column shows the settings used in the "Speaker Configuration" window.

The "Current Connection" column shows the types of devices detected during test. If the result does not match the physical connection, an exclamation mark will appear. (See **Figure D-14**)

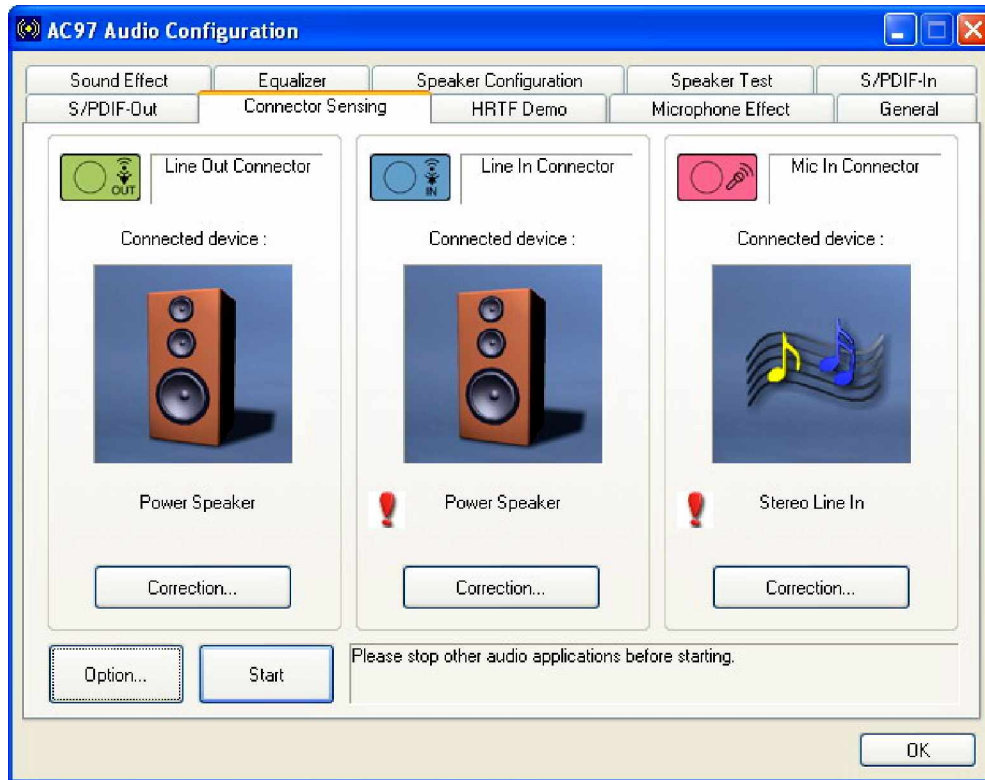

**Figure D-14: Connector Sensing Test Result**

After closing the EZ-Connector screen, the following window should appear showing the latest connection status.

## D.13 HRTF Demo

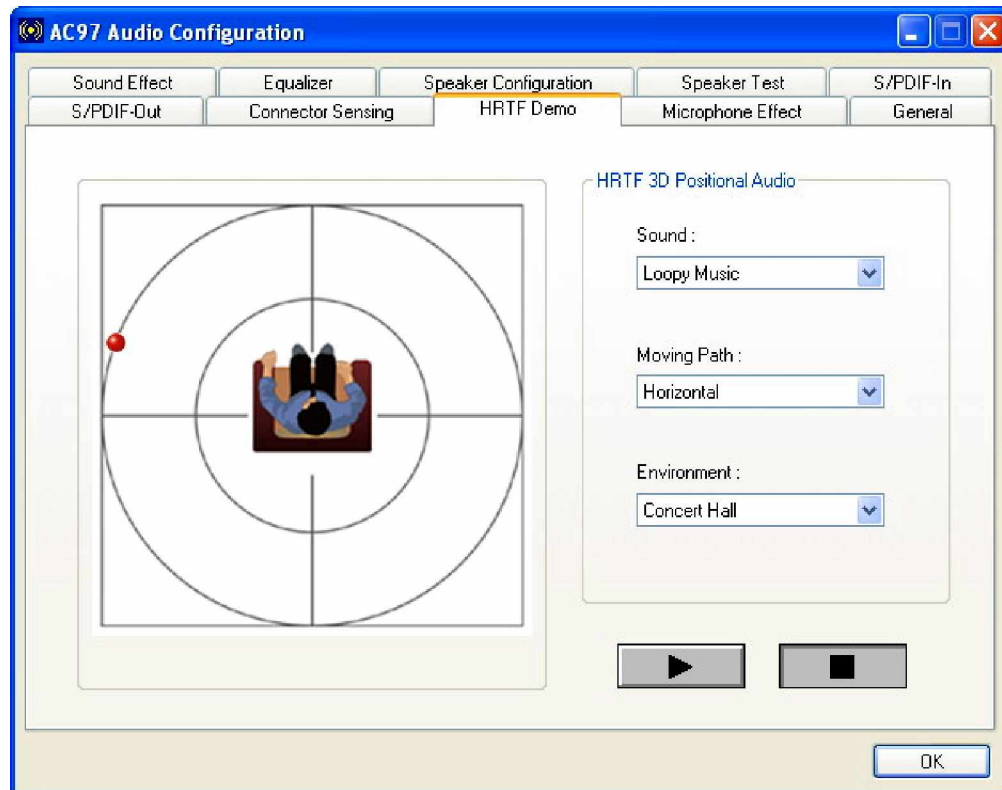

**Figure D-15: HRTF Demo**

The HRTF window in **Figure D-15** allows you to adjust your HRTF (Head Related Transfer Functions) 3D positional audio before playing 3D applications. Select a preferred **Environment** mode and/or different **Sound** and **Moving Path** settings.

## D.14 Microphone Effect

This window provides an option, Noise Suppression. Select its check box to enable this functionality.

## D.15 General

The general window in **Figure D-16** provides information about this AC'97 audio configuration utility including **Audio Driver** version, **DirectX** version, **Audio Controller**, and **AC'97 Codec**. You may also change the language of this utility through the **Language** pull-down menu.

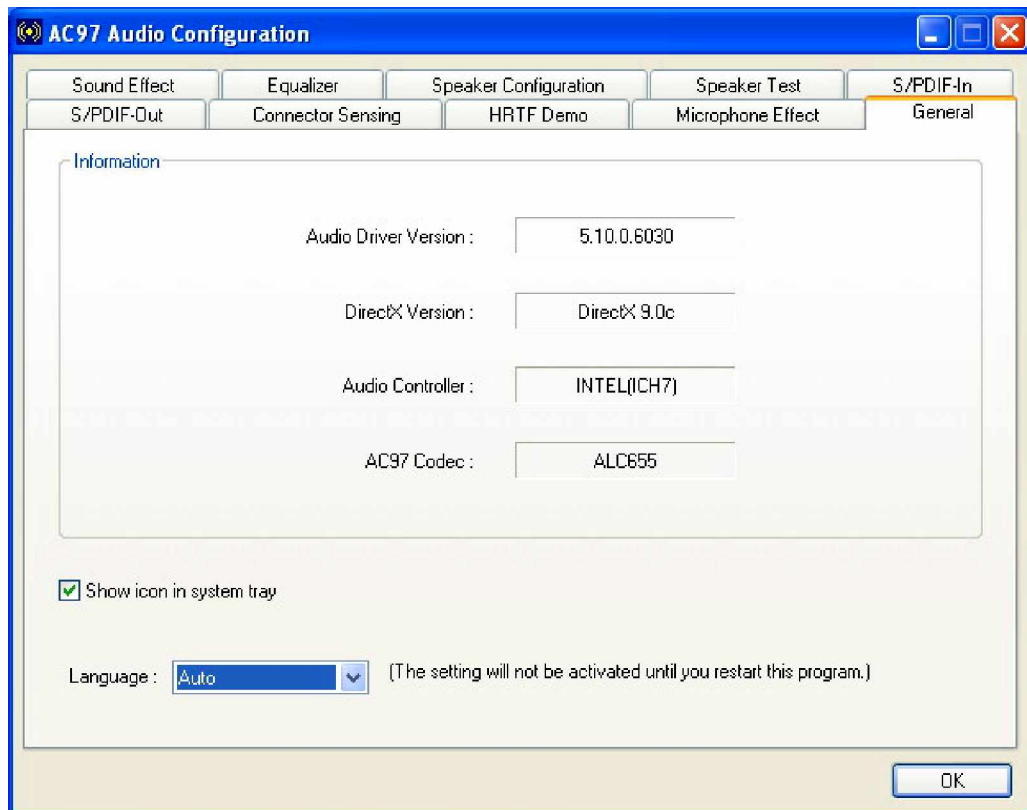

**Figure D-16: General**



# **E Index**

---

- 479-pin CPU, 77
- AC'97 connector, 19
- ACPI, 13, 20, 25, 175
- Address Mapping, 173, 193
- Advanced BIOS Features, 88, 95, 96, 97
- Advanced Chipset Features, 88, 107
- AMI flash BIOS, 20, 31
- ASKIR, 13, 30, 51
- ATA, 13, 19, 20, 25, 29, 32, 75, 82, 83
- ATX-12V power supply, 64
- backlight, 58
- backplanes, 22, 29
- battery voltage, 30
- BIOS, 12, 13, 16, 20, 30, 31, 47, 71, 85, 86, 87, 88, 89, 90, 91, 93, 95, 96, 103, 106, 107, 111, 114, 115, 118, 120, 121, 127, 135, 139, 163, 164, 170, 174
- bus masters, 27
- Celeron, 19
- chassis speaker, 50
- chipset driver, 144, 147
- Chipsets, 19, 24
- CMOS RAM, 20, 30
- CODEC, 31, 37, 61, 177, 178, 181
- cooling fan, 9, 31, 47, 77, 79, 81
- Cooling fans, 20
- cooling kit, 77, 84
- Cooling Kit, 79
- CPU board, 2, 16, 17, 19, 22, 23, 25, 28, 30, 31, 32, 39, 55, 61, 65, 76
- CPU card, 22, 31, 39, 65, 74, 75, 76, 82, 83, 144, 148, 151, 156, 178
- CPU cooling fan, 18, 37
- CPU socket, 78
- daisy-chain, 39
- data flow, 25
- DDR2, 17, 19, 24, 27, 81
- digital visual interface, 55
- DIMM module, 81, 82
- DIMM modules, 77, 81, 82, 84
- DIMM socket, 82
- DIO, 13
- DOS environment, 170
- dual channel, 17
- DVI connector, 18, 37
- Environment Simulation, 182
- Ethernet, 84
- Ethernet connectors, 67
- Example program, 171
- Execute Disable Bit, 105
- FDD, 8, 10, 13, 18, 20, 28, 29, 33, 37, 39, 40, 82, 83, 98, 99, 102, 123, 134, 165
- FDD connector, 18
- FDD1, 83
- Floppy, 83
- Floppy Disk Drive, 13, 20, 29
- front panel, 50
- front panel connector, 18
- FSB, 13, 17, 31
- FSB Speed, 69, 84
- Gigabit Ethernet, 17, 20, 156
- gigabit Ethernet controller driver, 144
- Graphics Media Accelerator, 19, 24, 148
- HDD, 13, 18, 20, 29, 37, 39, 41, 50, 82, 83, 93, 94, 95, 97, 98, 115, 116, 117, 129, 131, 164, 166, 167
- HDD connector, 18
- HDD Interface, 20
- Head Related Transfer Functions, 191
- heat dissipation, 80

- heat sink, 31
- IDE, 82
- IDE channel, 20
- IDE connector, 41, 83
- Integrated Peripherals, 88, 114, 115, 118, 121
- Intel® 915GV, 19, 24, 26
- Intel® ICH6, 19, 24, 27
- Inverter connector, 18, 37
- inverter control, 58
- IrDA, 13, 20, 30, 51, 52
- IrDA connector, 18
- Jack Sensing, 188
- jumpers, 38, 69, 83, 84
- Karaoke mode, 184
- keyboard connector, 19, 38
- LAN connectivity, 28
- LAN LED connectors, 18
- LAN ports, 28
- LCD Panel, 84
- LGA 775, 17
- LGA775, 2
- locked position, 78
- low voltage, 22
- LPT, 13, 33, 37, 44, 45
- LVDS connector, 18, 57
- Microphone Effect, 191
- mini jumper, 32, 75
- multi-mode, 16
- Northbridge, 19, 24
- onboard jumpers, 36, 38, 69, 83
- operating temperatures, 31
- Panel Voltage Selection, 69, 70, 83
- parallel port, 18, 37, 44, 126
- password, 89, 121, 122, 164, 166
- PC Health Status, 88, 139
- PCI Bus Interface, 19, 27
- PCI Express, 17, 20, 24, 27
- PCIPnP, 88
- Pentium, 10, 16, 19, 22, 23
- Pentium 4, 16
- peripheral connectors, 36, 39, 65, 84
- PICMG, Error! Not a valid bookmark in entry on page 16, Error! Not a valid bookmark in entry on page 17
- PIO IDE, 29
- Power Management Setup, 88, 127
- power source, 48
- power switch, 50
- Pre-Boot Execution Environment, 31
- Prescott, 19
- PS/2 mouse and keyboard connectors, 65
- PS2, 32, 76, 82
- Real Time Clock, 20, 30
- rear panel connectors, 38
- reset button, 50
- Reset CMOS, 69, 70, 83
- Reset CMOS Jumper, 70, 71
- RJ-45 Connector, 38
- RJ-45 Ethernet connector, 67
- RoHS, 17
- RPM, 30
- RS-232, 18, 30, 32, 76, 82
- RS-232 connectors, 18
- SATA, 8, 10, 13, 17, 18, 19, 25, 28, 29, 32, 37, 53, 54, 76, 82, 117, 118, 166, 175
- SATA cable, 32, 76
- SATA controller, 25
- SATA drive ports, 53
- SATA drives, 28
- SATA power cable, 32, 53, 76, 82
- SATAII, 17, 18, 28, 29, 30, 32, 37, 76

## 3301650 CPU Card

Serial Infrared, 13, 30  
Serial Ports, 20, 30  
Shift Keyed Infrared, 13, 30  
SIR, 13, 30, 51  
SMIBIOS, 31  
software drivers, 144  
Sound Effect Manager, 180, 181  
sound environment, 182  
Southbridge, 19, 24  
SpeedStep, 13  
Standard CMOS Features, 88, 90  
System Bus, 24  
system cooling fan, 18  
system voltages, 20, 107, 114, 127, 135, 139  
technical specifications, 19  
temperature, 20, 31  
temperatures, 16, 30, 139  
through holes, 80  
UART, 13, 30, 42  
ultra low voltage, 22  
Unpacking, 75  
USB, 8, 10, 13, 17, 19, 20, 25, 30, 31, 32, 37, 38, 45, 46, 65, 66, 76, 82, 84, 99, 118, 119, 133, 166, 167  
VGA connector, 38, 65, 68  
Virtual Cable Tester, 28  
Watchdog Timer, 169, 170, 171  
WSB-9154, 2, 16, 17, 18, 19, 22, 23, 27, 28, 29, 30, 31, 32, 36, 39, 55, 61, 65, 69, 74, 75, 76, 82, 83, 144, 148, 151, 156, 178  
x ATX 12V connector, 18  
x ATX backplane power connector, 18  
Y cable, 32, 76, 82

Any advice or comments about our products and service, or anything we can help you with please don't hesitate to contact with us. We will do our best to support you for your products, projects and business

### **Global American Inc.**

Address: 17 Hampshire Drive  
Hudson, NH 03051

TEL: Toll Free (U.S. Only) 800-833-8999  
(603)886-3900

FAX: (603)886-4545

Website: <http://www.globalamericaninc.com>

E-Mail: [salesinfo@globalamericaninc.com](mailto:salesinfo@globalamericaninc.com)

