



**User's Manual**

**3301690**

**REVISION HISTORY**

<b>Title</b>	Intel Pentium D/Pentium 4 LGA775 CPU board	
<b>Revision Number</b>	<b>Description</b>	<b>Date of Issue</b>
1.0	Initial release	March 2006

**COPYRIGHT NOTICE**

The information in this document is subject to change without prior notice in order to improve reliability, design and function and does not represent a commitment on the part of the manufacturer.

In no event will the manufacturer be liable for direct, indirect, special, incidental, or consequential damages arising out of the use or inability to use the product or documentation, even if advised of the possibility of such damages.

This document contains proprietary information protected by copyright. All rights are reserved. No part of this manual may be reproduced by any mechanical, electronic, or other means in any form without prior written permission of the manufacturer.

**TRADEMARKS**

IBM PC is a registered trademark of International Business Machines Corporation. INTEL is a registered trademark of INTEL Corporation. AMI is registered trademarks of American Megatrends Inc. Other product names mentioned herein are used for identification purposes only and may be trademarks and/or registered trademarks of their respective owners.

# Table of Contents

---

<b>1</b>	<b>INTRODUCTION.....</b>	<b>15</b>
1.1	3301690 CPU BOARD OVERVIEW .....	16
1.1.1	<i>3301690 CPU Board Applications</i> .....	16
1.1.2	<i>3301690 CPU Board Benefits</i> .....	16
1.1.3	<i>3301690 CPU Board Features</i> .....	16
1.2	3301690 CPU BOARD CPU CARD OVERVIEW .....	17
1.2.1	<i>3301690 CPU Board Connectors</i> .....	17
1.2.2	<i>Technical Specifications</i> .....	18
<b>2</b>	<b>DETAILED SPECIFICATIONS .....</b>	<b>20</b>
2.1	COMPATIBLE BACKPLANES .....	21
2.2	CPU SUPPORT.....	21
2.2.1	<i>P4 Prescott</i> .....	21
2.2.2	<i>Celeron D</i> .....	21
2.3	ONBOARD CHIPSETS .....	22
2.3.1	<i>Northbridge and Southbridge Chipsets</i> .....	22
2.3.2	<i>Intel® 915GV Northbridge Chipset</i> .....	22
2.3.3	<i>Intel® ICH6 Southbridge Chipset</i> .....	22
2.4	DATA FLOW .....	23
2.5	GRAPHICS SUPPORT .....	23
2.6	MEMORY SUPPORT .....	24
2.7	PCI BUS INTERFACE SUPPORT .....	24
2.8	ETHERNET CONNECTION .....	24
2.8.1	<i>PCI Express (PCI-E) Ethernet</i> .....	24
2.8.2	<i>GbE Ethernet</i> .....	24
2.9	DRIVE INTERFACES .....	25
2.9.1	<i>SATA Drives</i> .....	25
2.9.2	<i>HDD Interfaces</i> .....	25
2.9.3	<i>Floppy Disk Drive (FDD)</i> .....	25
2.10	SERIAL PORTS .....	26
2.11	REAL TIME CLOCK.....	26
2.12	SYSTEM MONITORING.....	26

2.13	INFRARED DATA ASSOCIATION (IRDA) INTERFACE .....	26
2.14	USB INTERFACES.....	26
2.15	BIOS .....	27
2.16	OPERATING TEMPERATURE AND TEMPERATURE CONTROL.....	27
2.17	OPTIONAL AUDIO INTERFACE.....	27
2.18	POWER CONSUMPTION .....	27
2.19	PACKAGED CONTENTS AND OPTIONAL ACCESSORY ITEMS.....	28
2.19.1	<i>Package Contents</i> .....	28
2.19.2	<i>Optional Accessory Items</i> .....	28
<b>3</b>	<b>CONNECTORS AND JUMPERS .....</b>	<b>29</b>
3.1	PERIPHERAL INTERFACE CONNECTORS .....	30
3.1.1	<i>3301690 CPU Board Overview</i> .....	30
3.1.2	<i>Peripheral Interface Connectors</i> .....	31
3.2	INTERNAL PERIPHERAL CONNECTORS .....	32
3.2.1	<i>FDD Connector</i> .....	32
3.2.2	<i>IDE Connectors</i> .....	34
3.2.3	<i>COM Ports</i> .....	35
3.2.4	<i>Parallel Port</i> .....	36
3.2.5	<i>DIO Connector</i> .....	38
3.2.6	<i>Internal USB Connectors</i> .....	39
3.2.7	<i>Cooling Fan</i> .....	40
3.2.8	<i>Backplane to Mainboard ATX Connector</i> .....	42
3.2.9	<i>System Front Panel Connector</i> .....	43
3.2.10	<i>IrDA Connector</i> .....	44
3.2.11	<i>SATA Drive Connectors (CN14 &amp; CN15)</i> .....	46
3.2.12	<i>DVI (Digital Visual Interface) Connector</i> .....	48
3.2.13	<i>LAN State LED Connector</i> .....	49
3.2.14	<i>AC'97 Connector</i> .....	51
3.2.15	<i>Keyboard Connector</i> .....	52
3.2.16	<i>ATX-12V Power Source Connector</i> .....	54
3.3	EXTERNAL (REAR PANEL) CONNECTORS .....	55
3.3.1	<i>PS/2 Connector</i> .....	55
3.3.2	<i>USB Connector</i> .....	56
3.3.3	<i>Ethernet Connector</i> .....	56
3.3.4	<i>VGA Connector</i> .....	57

3.4	ONBOARD JUMPERS .....	58
3.4.1	<i>Reset CMOS Jumper</i> .....	59
<b>4</b>	<b>INSTALLATION AND CONFIGURATION .....</b>	<b>61</b>
4.1	INSTALLATION CONSIDERATIONS .....	62
4.1.1	<i>Installation Notices</i> .....	62
4.2	UNPACKING.....	63
4.2.1	<i>Unpacking Precautions</i> .....	63
4.2.2	<i>Checklist</i> .....	63
4.3	3301690 CPU CARD INSTALLATION.....	64
4.3.1	<i>CPU Installation</i> .....	65
4.3.1.1	CPU Selection: HT Functionality Requirements .....	65
4.3.1.2	CPU Installation.....	65
4.3.2	<i>Cooling Kit (CF-520) Installation</i> .....	68
4.3.3	<i>DIMM Module Installation</i> .....	70
4.3.3.1	Purchasing the Memory Module.....	70
4.3.3.2	Memory Configuration Rules .....	70
4.3.3.3	DIMM Module Configurations.....	71
4.3.3.4	DIMM Module Installation.....	72
4.3.4	<i>Peripheral Device Connection</i> .....	72
4.3.4.1	IDE Disk Drive Connector (IDE1) .....	72
4.3.4.2	Floppy Drive Connector (FDD1).....	73
4.4	CHASSIS INSTALLATION .....	73
4.5	REAR PANEL CONNECTORS .....	74
4.5.1	<i>LCD Panel Connection (VGA1)</i> .....	74
4.5.2	<i>Ethernet Connection (LAN1 and LAN2)</i> .....	74
4.5.3	<i>USB Connection (USB_C6)</i> .....	74
<b>5</b>	<b>AMI BIOS SETUP .....</b>	<b>75</b>
5.1	INTRODUCTION .....	76
5.1.1	<i>Starting Setup</i> .....	76
5.1.2	<i>Using Setup</i> .....	76
5.1.3	<i>Getting Help</i> .....	77
5.1.4	<i>Unable to Reboot After Configuration Changes</i> .....	77
5.1.5	<i>BIOS Menu Bar</i> .....	77
5.2	MAIN .....	78

5.3	ADVANCED.....	79
5.3.1	<i>CPU Configuration</i> .....	80
5.3.2	<i>IDE Configuration</i> .....	83
5.3.2.1	IDE Master and IDE Slave .....	85
5.3.3	<i>Floppy Configuration</i> .....	88
5.3.4	<i>Super IO Configuration</i> .....	89
5.3.5	<i>Hardware Health Configuration</i> .....	91
5.3.6	<i>ACPI Configuration</i> .....	93
5.3.6.1	General ACPI Configuration.....	95
5.3.7	<i>MPS Configuration</i> .....	95
5.3.8	<i>Remote Access Configuration</i> .....	96
5.3.9	<i>USB Configuration</i> .....	99
5.4	PCI/PNP .....	101
5.5	BOOT .....	105
5.5.1	<i>Boot Settings Configuration</i> .....	106
5.5.2	<i>Boot Device Priority</i> .....	109
5.5.3	<i>Removable Drives</i> .....	109
5.6	SECURITY.....	110
5.7	CHIPSET .....	112
5.7.1	<i>North Bridge Configuration</i> .....	113
5.7.1.1	Video Function Configuration .....	115
5.7.2	<i>South Bridge Chipset Configuration</i> .....	117
5.8	POWER KEY .....	118
5.9	EXIT .....	122
<b>6</b>	<b>SOFTWARE DRIVERS .....</b>	<b>125</b>
6.1	AVAILABLE SOFTWARE DRIVERS .....	126
6.2	CHIPSET DRIVER INSTALLATION.....	126
6.3	INTEL GRAPHICS MEDIA ACCELERATOR DRIVER .....	130
6.4	REALTEK AUDIO DRIVER INSTALLATION .....	134
6.5	MARVELL GIGABIT ETHERNET CONTROLLER DRIVER INSTALLATION .....	139
<b>A</b>	<b>BIOS CONFIGURATION OPTIONS .....</b>	<b>145</b>
A.1	BIOS CONFIGURATION OPTIONS .....	146
<b>B</b>	<b>WATCHDOG TIMER .....</b>	<b>149</b>
<b>C</b>	<b>ADDRESS MAPPING.....</b>	<b>153</b>

C.1	IO ADDRESS MAP .....	154
C.2	1ST MB MEMORY ADDRESS MAP .....	154
C.3	IRQ MAPPING TABLE.....	155
C.4	DMA CHANNEL ASSIGNMENTS .....	155
<b>D</b>	<b>EXTERNAL AC'97 AUDIO CODEC .....</b>	<b>156</b>
D.1	INTRODUCTION .....	157
D.2	PHYSICAL CONNECTION.....	158
D.3	DRIVER INSTALLATION.....	159
D.4	SOUND EFFECT CONFIGURATION .....	160
D.5	SOUND EFFECT .....	161
D.6	ENVIRONMENT SIMULATION .....	161
D.7	KARAOKE MODE.....	162
D.8	EQUALIZER SELECTION.....	163
D.9	SPEAKER CONFIGURATION .....	164
D.10	SPEAKER TEST .....	165
D.11	S/PDIF-IN & S/PDIF-OUT .....	166
D.12	CONNECTOR SENSING .....	167
D.13	HRTF DEMO.....	170
D.14	MICROPHONE EFFECT .....	170
D.15	GENERAL .....	171
<b>INDEX</b> .....		<b>172</b>

# List of Figures

---

Figure 1-1: 3301690 CPU Board Board Overview .....	17
Figure 2-1: Data Flow Block Diagram.....	23
Figure 3-1: Peripheral Connector Locations .....	30
Figure 3-2: FDD Connector Location.....	33
Figure 3-3: IDE Connector Location .....	35
Figure 3-4: COM Port Locations.....	36
Figure 3-5: LPT Connector Location .....	38
Figure 3-6: DIO Connector Location.....	39
Figure 3-7: USB Port Connector Location .....	40
Figure 3-8: Cooling Fan Connector Locations .....	41
Figure 3-9: ATXCTL1 Connector Locations.....	42
Figure 3-10: System Panel Connector Location.....	44
Figure 3-11: IrDA Connector Location .....	45
Figure 3-12: SATA Connector Locations .....	47
Figure 3-13: DVI1 Connector Location .....	49
Figure 3-14: J_LANLED Connector Locations .....	50
Figure 3-15: J_AUDIO Connector Location .....	52
Figure 3-16: KB1 Connector Location.....	53
Figure 3-17: ATX Connector Location.....	54
Figure 3-18: 3301690 CPU Board Rear Panel.....	55
Figure 3-19: PS/2 Pin-out locations .....	56
Figure 3-20: RJ-45 Ethernet Connector.....	57
Figure 3-22: J_CMOS1 Jumper Location .....	60
Figure 4-1: Intel LGA775 Socket .....	66
Figure 4-2: Remove the CPU Socket Protective Shield.....	66
Figure 4-3: Open the CPU Socket Load Plate.....	67
Figure 4-4: Insert the CPU .....	67
Figure 4-5: Cooling Kit.....	68
Figure 4-6: Securing the heatsink to the PCB board .....	69



Figure 4-7: DIMM Sockets.....	71
Figure 6-1: Extracting Driver Installation Files.....	127
Figure 6-2: Chipset Driver Installation Welcome Screen .....	127
Figure 6-3: Chipset Driver Installation License Agreement.....	128
Figure 6-4: Chipset Driver Readme File Information .....	129
Figure 6-5: Chipset Driver Installation Complete.....	130
Figure 6-6: GMA Driver Readme File .....	131
Figure 6-7: GMA Driver File Extraction .....	131
Figure 6-8: GMA Driver Installation Welcome Screen .....	132
Figure 6-9: GMA Driver License Agreement .....	133
Figure 6-10: GMA Driver Installing Notice .....	133
Figure 6-11: GMA Driver Installation Complete.....	134
Figure 6-12: Audio Driver Install Shield Wizard Starting.....	135
Figure 6-13: Audio Driver Setup Preparation.....	135
Figure 6-14: Audio Driver Welcome Screen.....	136
Figure 6-15: Audio Driver Software Configuration.....	136
Figure 6-16: Audio Driver Digital Signal.....	137
Figure 6-17: Audio Driver Installation Begins .....	138
Figure 6-18: Audio Driver Installation Complete.....	139
Figure 6-19: Ethernet Controller Driver Install Shield Wizard Starting.....	140
Figure 6-20: Ethernet Controller Driver Installation Welcome Screen.....	140
Figure 6-21: Ethernet Driver License Agreement.....	141
Figure 6-22: GMA Driver Installing Notice .....	142
Figure 6-23: Ethernet Driver is Installed .....	143
Figure 6-24: Ethernet Driver Installation Confirmation.....	144
Figure D-1: Audio Functionalities via the Audio Kit .....	158
Figure D-2: Audio Kit Connectors.....	158
Figure D-3: Sound Effect Manager Icon .....	159
Figure D-4: Sound Effect Manager Icon [Control Panel] .....	160
Figure D-5: Sound Effect Manager Icon [Task Bar] .....	160
Figure D-6: Setting Sound Effects .....	161
Figure D-7: Sound Effects Properties Editor .....	162

Figure D-8: Karaoke Mode .....	162
Figure D-9: Equalizer Settings .....	163
Figure D-10: Speaker Configuration.....	164
Figure D-11: Audio Configuration.....	165
Figure D-12: Connector Sensing.....	167
Figure D-13: EX Connection .....	168
Figure D-14: Connector Sensing Test Result .....	169
Figure D-15: HRTF Demo.....	170
Figure D-16: General .....	171

# List of Tables

---

Table 1-1: Technical Specifications.....	19
Table 2-1: Supported CPUs .....	21
Table 2-2: Power Consumption.....	28
Table 3-1: FDD Connector Pinouts .....	33
Table 3-2: IDE Connector Pinouts.....	34
Table 3-3: Internal COM Port Connector Pinouts.....	36
Table 3-4: LPT Connector Pinouts.....	37
Table 3-5: DIO Connector Pinouts .....	39
Table 3-6: USB Port Connector Pinouts.....	40
Table 3-7: Cooling Fan Connector Pinouts.....	41
Table 3-8: ATXCTL1 Connector Pin Outs.....	42
Table 3-9: System Panel Connector Pinouts .....	43
Table 3-10: IrDA Connector Pinouts.....	45
Table 3-11: SATA Connector Pinouts.....	46
Table 3-12: DVI Connector Pinouts.....	48
Table 3-13: J_LANLED Connector Pinouts.....	50
Table 3-14: J_AUDIO1 Connector Pinouts.....	51
Table 3-15: KB1 Connector Pinouts .....	53
Table 3-16: ATX Connector Pinouts .....	54
Table 3-17: PS/2 Pinouts.....	56
Table 3-18: USB Connectors .....	56
Table 3-19: RJ-45 Ethernet Connector Pinouts.....	57
Table 3-20: RJ-45 Ethernet Connector LEDs.....	57
Table 3-21: VGA Connector Pinouts.....	58
Table 3-22: Jumpers.....	59
Table 3-23: J_CMOS1 Jumper Settings.....	59
Table 4-1: Dual Memory Channel Configuration Options .....	71
Table 4-2: Provided Cables .....	72

<b>Table 5-1: BIOS Navigation Keys.....</b>	<b>77</b>
<b>Table B-1: AH-6FH Sub-function.....</b>	<b>150</b>
<b>Table C-1: IO Address Map.....</b>	<b>154</b>
<b>Table C-2: 1<sup>st</sup> MB Memory Address Map.....</b>	<b>154</b>
<b>Table C-3: IRQ Mapping Table.....</b>	<b>155</b>
<b>Table C-4: IRQ Mapping Table.....</b>	<b>155</b>

# List of BIOS Menus

---

Menu 1: Main .....	78
Menu 2: Advanced.....	80
Menu 3: CPU Configuration [Advanced].....	81
Menu 4: IDE Configuration [Advanced].....	83
Menu 5: IDE Master and IDE Slave Configuration [Advanced/IDE Configuration] ...	86
Menu 5: Floppy Configuration [Advanced].....	88
Menu 6: Super IO Configuration [Advanced].....	89
Menu 7: Hardware Health Configuration [Advanced] .....	92
Menu 8: ACPI Configuration [Advanced] .....	94
Menu 9: General ACPI Configuration [Advanced\ ACPI Configuration] .....	95
Menu 10: MPS Configuration [Advanced].....	96
Menu 11: Remote Access Configuration [Advanced].....	97
Menu 13: USB Configuration [Advanced] .....	100
Menu 14: PCI/PnP Configuration [Part 1].....	102
Menu 14: PCI/PnP Configuration [Part 2].....	103
Menu 15: Boot .....	106
Menu 16: Boot Settings Configuration [Boot] .....	107
Menu 17: Boot Device Priority Settings [Boot].....	109
Menu 18: Removable Drives [Boot] .....	110
Menu 19: Security .....	111
Menu 20: Chipset.....	113
Menu 21:NorthBridge Chipset Configuration [Chipset] .....	114
Menu 22:Video Function Configuration [Chipset/Northbridge].....	116
Menu 23:SouthBridge Chipset Configuration [Chipset].....	117
Menu 24:Power .....	119
Menu 25:Exit .....	123

# Glossary

---

AC '97	Audio Codec 97	IDE	Integrated Data Electronics
ACPI	Advanced Configuration and Power Interface	I/O	Input/Output
APM	Advanced Power Management	ICH4	I/O Controller Hub 4
ARMD	ATAPI Removable Media Device	L1 Cache	Level 1 Cache
ASKIR	Shift Keyed Infrared	L2 Cache	Level 2 Cache
ATA	Advanced Technology Attachments	LCD	Liquid Crystal Display
BIOS	Basic Input/Output System	LPT	Parallel Port Connector
CFII	Compact Flash Type 2	LVDS	Low Voltage Differential Signaling
CMOS	Complementary Metal Oxide Semiconductor	MAC	Media Access Controller
CPU	Central Processing Unit	OS	Operating System
Codec	Compressor/Decompressor	PCI	Peripheral Connect Interface
COM	Serial Port	PIO	Programmed Input Output
DAC	Digital to Analog Converter	PnP	Plug and Play
DDR	Double Data Rate	POST	Power On Self Test
DIMM	Dual Inline Memory Module	RAM	Random Access Memory
DIO	Digital Input/Output	SATA	Serial ATA
DMA	Direct Memory Access	S.M.A.R.T	Self Monitoring Analysis and Reporting Technology
EIDE	Enhanced IDE	SPD	Serial Presence Detect S/PDI
EIST	Enhanced Intel SpeedStep Technology	Sony/Philips	Digital Interface
FDD	Floppy Disk Drive	SDRAM	Synchronous Dynamic Random Access Memory
FDC	Floppy Disk Connector	SIR	Serial Infrared
FIFO	First In/First Out	UART	Universal Asynchronous Receiver-transmitter
FSB	Front Side Bus	USB	Universal Serial Bus
IrDA	Infrared Data Association	VGA	Video Graphics Adapter
HDD	Hard Disk Drive		

Chapter

1

# 1 Introduction

---

### 1.1 3301690 CPU Board Overview

The PICMG form factor 3301690 LGA775 Pentium 4 CPU board is fully equipped with a high performance processor and advanced multi-mode I/Os. The 3301690 is designed for system manufacturers, integrators, and VARs that want performance, reliability, and quality at a reasonable price.

#### 1.1.1 3301690 CPU Board Applications

The 3301690 CPU board has been designed for use in industrial applications where board expansion is critical and operational reliability is essential.

#### 1.1.2 3301690 CPU Board Benefits

Some of the 3301690 CPU board benefits include,

- „ providing access to multiple PCI and ISA expansion slots for easy system expansion
- „ operating reliably in harsh industrial environments with ambient temperatures as high as 60°C
- „ rebooting automatically if the BIOS watchdog timer detects that the system is no longer operating

#### 1.1.3 3301690 CPU Board Features

Some of the 3301690 CPU board features are listed below:

- „ Complies with PICMG 1.0
- „ Complies with RoHS
- „ Supports Intel® LGA 775 P4 Prescott CPU or Intel® Celeron D CPU
- „ Supports a front side bus (FSB) speed up to 800MHz
- „ Supports up to 4GB of 400MHz or 533MHz dual channel DDR2 memory
- „ Comes with two dual high performance PCI Express Gigabit Ethernet controllers
- „ Supports four SATA-I, 150Gb/s channels
- „ Supports seven USB 2.0 connectors



## 1.2 3301690 CPU Board CPU Card Overview

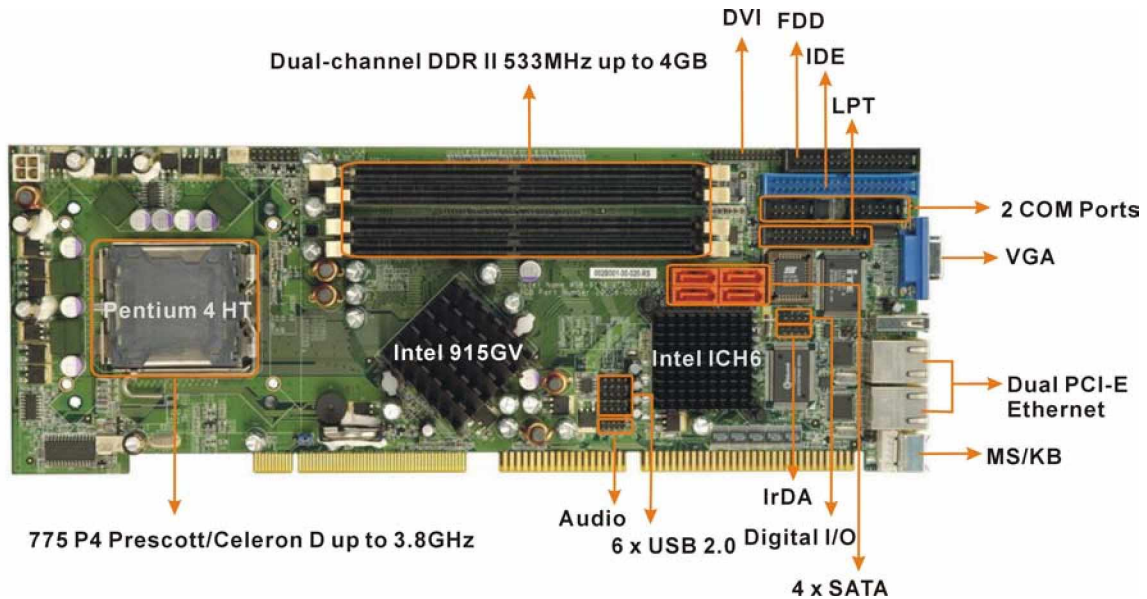

Figure 1-1: 3301690 CPU Board Board Overview

### 1.2.1 3301690 CPU Board Connectors

The 3301690 CPU Board has the following connectors onboard:

- „ 2 x RS-232
- „ 1 x LPT connector
- „ 1 x IrDA connector
- „ 7 x USB 2.0 connectors
- „ 4 x SATA connectors for 150Bb/s SATA transmission
- „ 1 x ATA channel
- „ 1 x FDD connector
- „ 1 x PS/2 keyboard/mouse connector
- „ 1 x GPI and GPO connector

The location of these connectors on the CPU Card can be seen in **Figure 1-1**. These connectors are fully described in **Chapter 3**.

## 1.2.2 Technical Specifications

3301690 CPU board technical specifications are listed in **Table 1-1**. Detailed descriptions of each specification can be found in **Chapter 2 Detailed Specifications**.

SPECIFICATION	
<b>CPUs Supported</b>	Intel® Pentium® 4 Prescott Intel® Celeron D
<b>Chipsets</b>	<b>Northbridge:</b> Intel® 915GV <b>Southbridge:</b> Intel® ICH6
<b>I/O Controller</b>	Intel® I/O Controller Hub 6 (ICH6)
<b>Graphics Support</b>	Intel® Graphics Media Accelerator 900 (Intel® GMA 900)
<b>Memory</b>	Four DDR2 memory modules (Max. 4GB)
<b>PCI Bus Interface</b>	33MHz, Revision 2.3
<b>Serial ATA (SATA)</b>	Four 150MB/s SATA channels
<b>HDD Interface</b>	One IDE channel supports two Ultra ATA 100/66/33 devices
<b>Floppy Disk Drive (FDD)</b>	Supports FDD
<b>USB Interfaces</b>	Seven USB 2.0 connectors supported
<b>Serial Ports</b>	Two RS-232
<b>Real Time Clock</b>	256-byte battery backed CMOS RAM
<b>Hardware Monitoring</b>	Cooling fans, temperature and system voltages
<b>Power Management</b>	Supports Advanced Configuration and Power Interface (ACPI) Specifications Revision 2.0
<b>Infrared Support</b>	One Infrared Data Association (IrDA) interface
<b>Ethernet</b>	PCI Express Gigabit Ethernet (PCI-E GbE)
<b>BIOS</b>	AMI flash BIOS

## 3301690 CPU Card

<b>Physical Dimensions</b>	12.2cm x 34.1cm (width x length)
<b>Operating Temperature</b>	Minimum: 0°C (32°F) Maximum: 60°C (140°F)
<b>Optional Audio Interfaces</b>	One Audio CODEC '97 (AC'97) version 2.3 connector connects to an external audio CODEC, an audio module

**Table 1-1: Technical Specifications**

Chapter

2

# 2 Detailed Specifications

---

## 2.1 Compatible GAI Backplanes

For more information on these backplanes, please visit the GAI website ([www.globalamericaninc.com](http://www.globalamericaninc.com)) or contact your CPU card reseller or vendor.

## 2.2 CPU Support

Table 2-1 lists the CPUs supported by the 3301690 CPU board.

Mfg.	Model	Max. Speed	L2 Cache	Max. FSB	Socket
Intel®	Pentium® 4 (P4) Prescott	3.80GHz	2MB	800MHz	LGA 775
Intel®	Celeron D	3.33GHz	256KB	533MHz	LGA 775

**Table 2-1: Supported CPUs**

### 2.2.1 P4 Prescott

The P4 Prescott CPU comes with the following features:

- „ Hyper-Threading Technology (HT Technology) ensures greater performance
- „ SpeedStep® Technology improves overall system power management
- „ Execute Disable Bit technology prevents certain classes of malicious "buffer overflow" attacks when combined with a supporting operating system.

### 2.2.2 Celeron D

The LGA 775 Celeron D CPU comes with the following features:

- „ Advanced Dynamic Execution Technology keeps the execution units executing instructions
- „ Intel® Streaming SIMD Extensions accelerates 3D graphics performance
- „ Execute Disable Bit Technology prevents certain classes of malicious "buffer overflow" attacks when combined with a supporting operating system.

## 2.3 Onboard Chipsets

### 2.3.1 Northbridge and Southbridge Chipsets

The following chipsets are preinstalled on the board:

- „ **Northbridge:** Intel® 915GV
- „ **Southbridge:** Intel® ICH6

The following two sections (**Section 2.3.2** and **Section 2.3.3**) lists some of the features of the Intel® 915GV and the Intel® ICH6 chipsets. For more information on these two chipsets please refer to the Intel website.

### 2.3.2 Intel® 915GV Northbridge Chipset

The Intel® 915GV northbridge chipset comes with the following features:

- „ Supports 800MHz or 533MHz System Bus
- „ Supports Intel® HT Technology
- „ Implements Intel® Graphics Media Accelerator 900 (GMA 900)
- „ Implements PCI Express (PCI-E) technology
- „ Supports DDR2 DIMM memory modules
- „ Integrates a SATA controller that controls four 150MB/s SATA channels
- „ Integrates Intel® High Definition Audio for new audio formats

### 2.3.3 Intel® ICH6 Southbridge Chipset

The Intel® ICH6 southbridge chipset comes with the following features:

- „ Complies with PCI Express Base Specification Revision 1.0a
- „ Complies with PCI Local Bus Specification Revision 2.3 and supports 33MHz PCI operation
- „ Supports ACPI power management
- „ Integrates SATA host controller with independent DMA operation on four ports
- „ Supports Ultra ATA 100/66/33 with an integrated IDE controller]
- „ Supports eight USB 2.0 ports but only seven are implemented on the 3301690
- „ Supports AC'97 Revision 2.3 Specifications

- „ Complies with System Management Bus Interface (SMBus) Specification Version 2.0

## 2.4 Data Flow

Figure 2-1 shows the data flow between the user-installed LGA 775 CPU, the two onboard chipsets and other components installed on the CPU board and described in the following sections of this chapter.

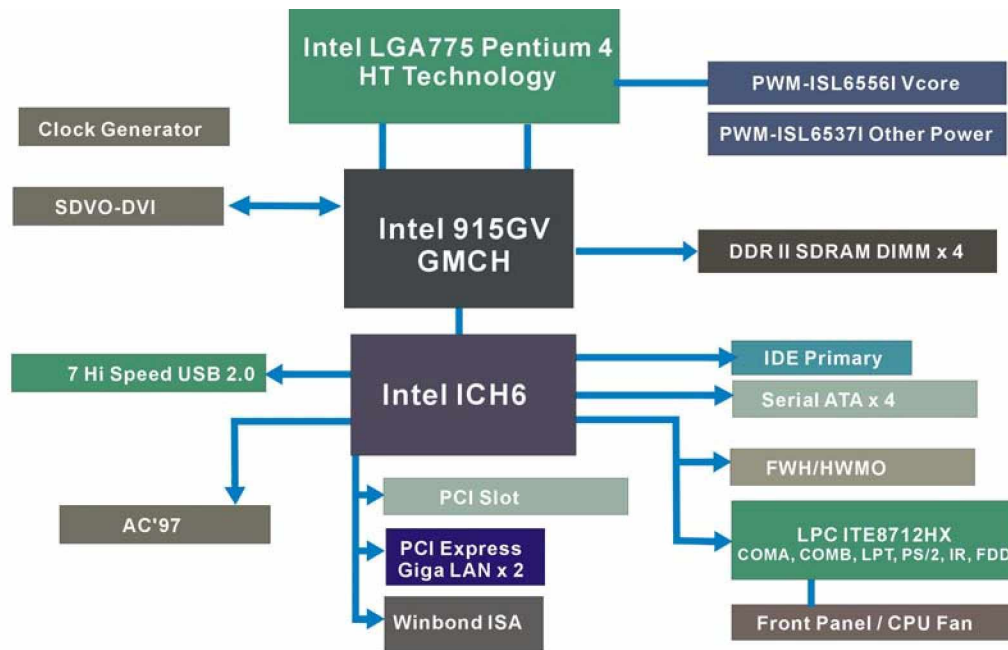

Figure 2-1: Data Flow Block Diagram

## 2.5 Graphics Support

The Intel® 915GV chipset integrates the Intel® GMA 900, which has the following features.

- „ 333MHz, 256-bit graphics core
- „ DirectX 9 hardware acceleration
- „ 8/16/32 bpp
- „ Up to 8.5 GB/sec memory bandwidth
- „ 1.3 GP/sec and 1.3 GT/sec fill rate
- „ 224MB maximum video memory
- „ 2048x1536 at 85 Hz maximum resolution

- „ Dynamic Display Modes for flat-panel and wide-screen support

## 2.6 Memory Support

The 3301690 CPU has four 240-pin dual inline memory module (DIMM) sockets and supports up to four DDR2 DIMMs with the following specifications:

- „ **Maximum RAM:** 4GB
- „ **DIMM Transfer Rates:** 533MHz, 400MHz
- „ **Dual Channel Support:** DDR2 533/DDR2 400
- „ **Peak Memory Bandwidth:** 8.5GB/s

## 2.7 PCI Bus Interface Support

The PCI bus on the 3301690 CPU Board has the following features:

- „ 33MHz Revision 2.3 is implemented
- „ Up to seven external bus masters are supported
- „ Maximum throughput: 133MB/sec
- „ Master devices: Maximum of six with three implemented
- „ One PCI REQ/GNT pair can be given higher arbitration priority (intended for external 1394 host controller)
- „ 44-bit addressing using the DAC protocol supported

## 2.8 Ethernet Connection

### 2.8.1 PCI Express (PCI-E) Ethernet

The PCI-E implemented on the Intel® ICH6 southbridge chipset connects directly to two Gigabit Ethernet (GbE) controllers (Marvell Yukon 88E8053) with a concurrent bandwidth of 5Gb/s (2.5Gb/s in each direction).

### 2.8.2 GbE Ethernet

The two Gigabit Ethernet (GbE) controllers (Marvell Yukon 88E8053) on the 3301690 CPU board connect to two 10/100/1000Mb/s Ethernet RJ-45 LAN ports on the rear panel. The GbE controllers come with the following features:



- „ Dual 1Gb/s external LAN connectivity
- „ Marvell Virtual Cable Tester (VCT) technology
- „ Wake-on-LAN support

## 2.9 Drive Interfaces

The 3301690 can support:

- „ 4 x SATA drives
- „ 2 x HDDs
- „ 1 x FDD

### 2.9.1 SATA Drives

The 3301690 CPU Board supports four, first generation SATA channels with transfer rates up to 150Gb/s.

### 2.9.2 HDD Interfaces

The 3301690 southbridge chipset IDE controller supports up to two HDDs with the following specifications:

- „ Supports PIO IDE transfers up to 16MB/s
- „ Supports the following Ultra ATA devices:
  - „ **Ultra ATA/33**, with data transfer rates up to 33MB/s
  - „ **Ultra ATA/66**, with data transfer rates up to 66MB/s
  - „ **Ultra ATA/100**, with data transfer rates up to 100MB/s

### 2.9.3 Floppy Disk Drive (FDD)

The 3301690 CPU Board supports a single FDD. The following FDD formats are compatible with the board.

- „ 5.25": 360KB and 1.2MB
- „ 3.5": 720KB, 1.44MB and 2.88MB

### 2.10 Serial Ports

The 3301690 CPU Board has two high-speed UART serial ports, configured as COM1 and COM2. The serial ports have the following specifications.

- „ 16C550 UART with 16-byte FIFO buffer
- „ 115.2Kbps transmission rate

### 2.11 Real Time Clock

256-byte battery backed CMOS RAM

### 2.12 System Monitoring

The 3301690 CPU board is capable of self-monitoring various aspects of its operating status including:

- „ CPU, chipset, and battery voltage, +3.3V, +5V, and +12V
- „ RPM of cooling fans
- „ CPU and board temperatures (by the corresponding embedded sensors)

### 2.13 Infrared Data Association (IrDA) Interface

The 3301690 CPU Board IrDA supports the following interfaces.

- „ Serial Infrared (SIR)
- „ Shift Keyed Infrared (ASKIR)

If you want to use the IrDA port, you have to configure SIR or ASKIR model in the BIOS under Peripheral Setup COM2. Then the normal RS-232 COM 2 will be disabled.

### 2.14 USB Interfaces

The 3301690 CPU Board has seven USB interfaces, six internal and one external. The USB interfaces support USB2.0. The six internal USB interfaces require USB adapter kits.

## 2.15 BIOS

The 3301690 CPU Board uses a licensed copy of AMI flash BIOS. The features of the flash BIOS used are listed below:

- „ SMIBIOS (DMI) compliant
- „ Console redirection function support
- „ PXE (Pre-Boot Execution Environment ) support
- „ USB booting support

## 2.16 Operating Temperature and Temperature Control

The maximum and minimum operating temperatures for the 3301690 CPU Board are listed below.

- „ Minimum Operating Temperature: 0°C (32°F)
- „ Maximum Operating Temperature: 60°C (140°F)

A cooling fan and heat sink must be installed on the CPU. The lower side of the heat sink, which is mounted on the CPU must be smeared with thermal paste. This ensures the proper dissipation of heat generated by the CPU.

Heat sinks are also mounted on the northbridge and southbridge chipsets to ensure that the operating temperature of these chips remain low.

## 2.17 Optional Audio Interface

The 3301690 CPU board does not come with an onboard CODEC but the Intel ICH6 chipset Audio Codec (AC'97) controller. A connector on the CPU card can be used to connect the ICH6 audio controllers to an external CODEC.

## 2.18 Power Consumption

**Table 2-2** shows the power consumption parameters for the 3301690 CPU board when a Pentium 4 processor with a clock speed of 3.4GHz, an L2 cache of 2MB and a FSB 800MHz is running with two 1GB, 533MHz DDR modules.

Voltage	Current
+5V	3.86A
+12V	5.21A

**Table 2-2: Power Consumption**

## 2.19 Packaged Contents and Optional Accessory Items

### 2.19.1 Package Contents

When you unpack the 3301690 CPU board you should find the following components.

- „ 1 x 3301690 system host board computer
- „ 1 x mini jumper pack
- „ 1 x ATA 66/100 flat cable
- „ 2 x SATA cable
- „ 1 x SATA power cable
- „ 1 x Keyboard/ PS2 mouse Y cable
- „ 1 X RS-232 cable
- „ 1 x USB cable
- „ 1 x Utility CD
- „ 1 x User's Manual

### 2.19.2 Optional Accessory Items

The items shown in the list below are optional accessory items that you must purchase separately.

- „ Audio cable
- „ CPU Cooler
- „ FDD cable
- „ LPT cable

Chapter

**3**

# **3 Connectors and Jumpers**

---

### 3.1 Peripheral Interface Connectors

The locations of the peripheral interface connectors are shown in **Section 3.1.1**. A complete list of all the peripheral interface connectors can be seen in **Section 3.1.2**.

#### 3.1.1 3301690 CPU Board Overview

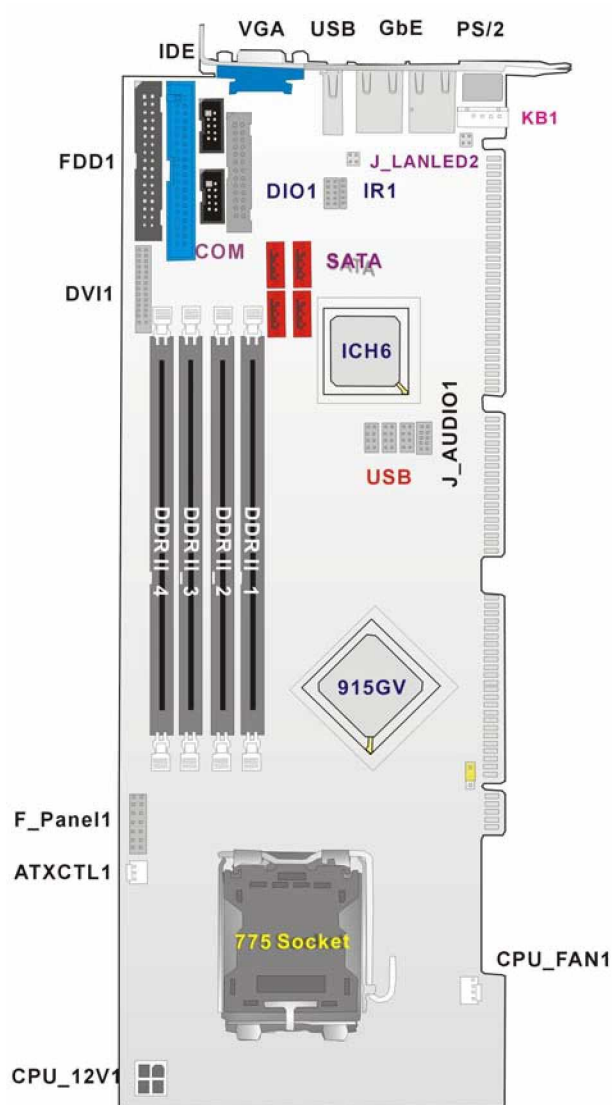

Figure 3-1: Peripheral Connector Locations

## 3.1.2 Peripheral Interface Connectors

Label	Connector	pe
FDD 1	FDD	34-pin floppy drive connector
IDE 1	HDD	40-pin ATA hard disk connector
COM 1	Serial Communications	2x5-pin RS-232 serial communications connector
COM 2	Serial Communications	2x5-pin RS-232 serial communications connector
LPT 1	Parallel Communications	26-pin parallel communications connector
SATA 1	SATA Drive	SATA disk drive port
SATA 2	SATA Drive	SATA disk drive port
SATA 3	SATA Drive	SATA disk drive port
SATA 4	SATA Drive	SATA disk drive port
DIO 1	Digital Input Output	
IR 1	Infrared	5-pin header IrDA connector
J_LANLED1	RJ-45 Connector LED	4-pin header
J_LANLED2	RJ-45 Connector LED	4-pin header
KB1	Keyboard connector	5-pin header
USB01	USB	8-pin header USB connector for two USBs
USB23	USB	8-pin header USB connector for two USBs
USB45	USB	8-pin header USB connector for two USBs
J_AUDIO1	AC'97 CODEC	10-pin header for optional connectivity to an AC'97 CODEC
F_PANEL1	Front Panel Connector	14-pin header to connect to chassis front panel power and rest buttons as well as

		status LEDs
<b>ATXCTL1</b>	<b>ATX connector</b>	3-pin header connects a power source from a backplane with an ATX Connector.
<b>CPU_FAN1</b>	<b>CPU Fan Power</b>	4-pin header CPU fan power cable connector

## 3.2 Internal Peripheral Connectors

Internal peripheral connectors are found on the CPU card and are only accessible when the CPU board is outside of the chassis. This section has complete descriptions of all the internal, peripheral connectors on the 3301690 CPU board.

### 3.2.1 FDD Connector

- CN Label:** FDD1
- CN Type:** 2x17 pin header
- CN Location:** See **Figure 3-2**
- CN Pinouts:** See **Table 3-1**

The 3301690 is shipped with a 34-pin daisy-chain drive connector cable. This cable can be connected to the FDD connector.

PIN	DESCRIPTION	PIN	DESCRIPTION
1	GND	2	REDUCE WRITE
3	GND	4	N/C
5	N/C	6	N/C
7	GND	8	INDEX#
9	GND	10	MOTOR ENABLE A#
11	GND	12	DRIVE SELECT B#
13	GND	14	DRIVE SELECT A#
15	GND	16	MOTOR ENABLE B#
17	GND	18	DIRECTION#
19	GND	20	STEP#



21	GND	22	WRITE DATA#
23	GND	24	WRITE GATE#
25	GND	26	TRACK 0#
27	GND	28	WRITE PROTECT#
29	GND	30	READ DATA#
31	GND	32	SIDE 1 SELECT#
33	GND	34	DISK CHANGE#

Table 3-1: FDD Connector Pinouts

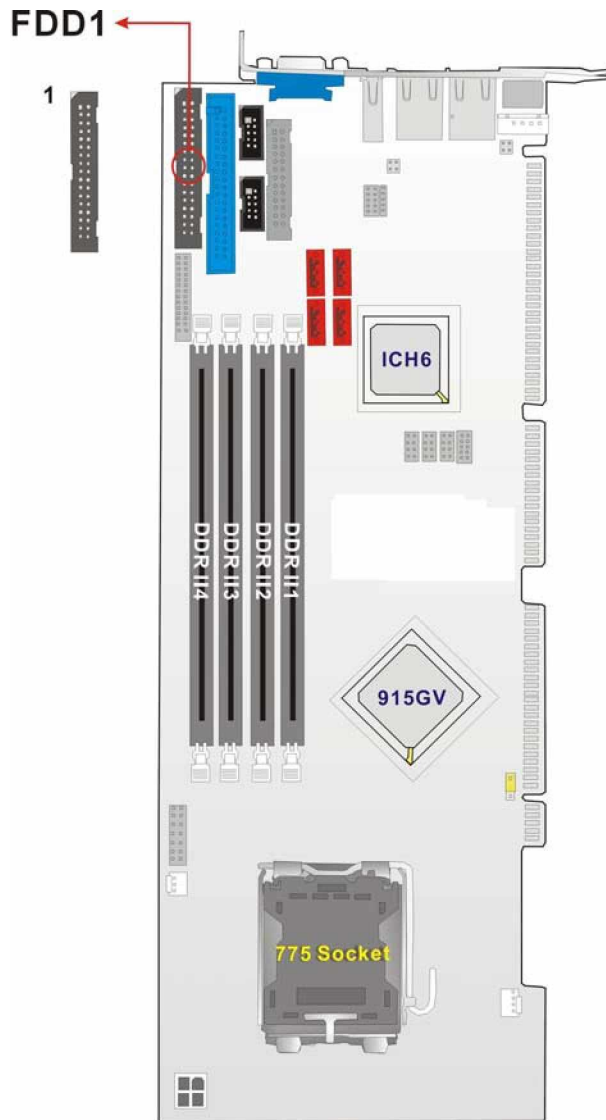

Figure 3-2: FDD Connector Location

### 3.2.2 IDE Connectors

- CN Label:** IDE1
- CN Type:** 2x20 pin header
- CN Location:** See Figure 3-3
- CN Pinouts:** See Table 3-2

One IDE connector provides connectivity for two IDE devices.

PIN NO.	DESCRIPTION		DESCRIPTION
1	RESET#	2	GND
3	DATA 7	4	DATA 8
5	DATA 6	6	DATA 9
7	DATA 5	8	DATA 10
9	DATA 4	10	DATA 11
11	DATA 3	12	DATA 12
13	DATA 2	14	DATA 13
15	DATA 1	16	DATA 14
17	DATA 0	18	DATA 15
19	GND	20	N/C
21	IDE DRQ	22	GND
23	IOW#	24	GND
25	IOR#	26	GND
27	IDE CHRDY	28	BALE – DEFAULT
29	IDE DACK	30	GND
31	INTERRUPT	32	N/C
33	SA1	34	PDIAG#
35	SA0	36	SA2
37	HDC CS0#	38	HDC CS1#
39	HDD ACTIVE#	40	GND

**Table 3-2: IDE Connector Pinouts**

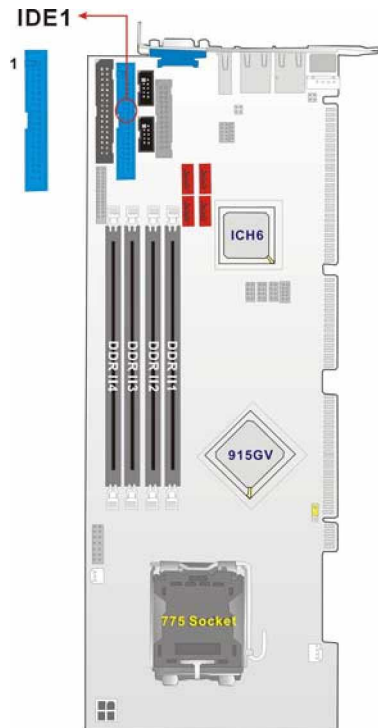

Figure 3-3: IDE Connector Location

### 3.2.3 COM Ports

<b>CN Label:</b>	<b>COM1, COM2</b>
<b>CN Type:</b>	<b>2x5 pin headers</b>
<b>CN Location:</b>	<b>See Figure 3-4</b>
<b>CN Pinouts:</b>	<b>See Table 3-3</b>

The WSB-9150 CPU board has two internal high-speed UART connectors that are accessed through a 2x5-pin cable connector.

PIN	DESCRIPTION		
1	DATA CARRIER DETECT (DCD)	6	DATA SET READY (DSR)
2	RECEIVE DATA (RXD)	7	REQUEST TO SEND (RTS)
3	TRANSMIT DATA (TXD)	8	CLEAR TO SEND (CTS)
4	DATA TERMINAL READY (DTR)	9	RING INDICATOR (RI)
5	GND (GND)	10	GND (GND)

Table 3-3: Internal COM Port Connector Pinouts

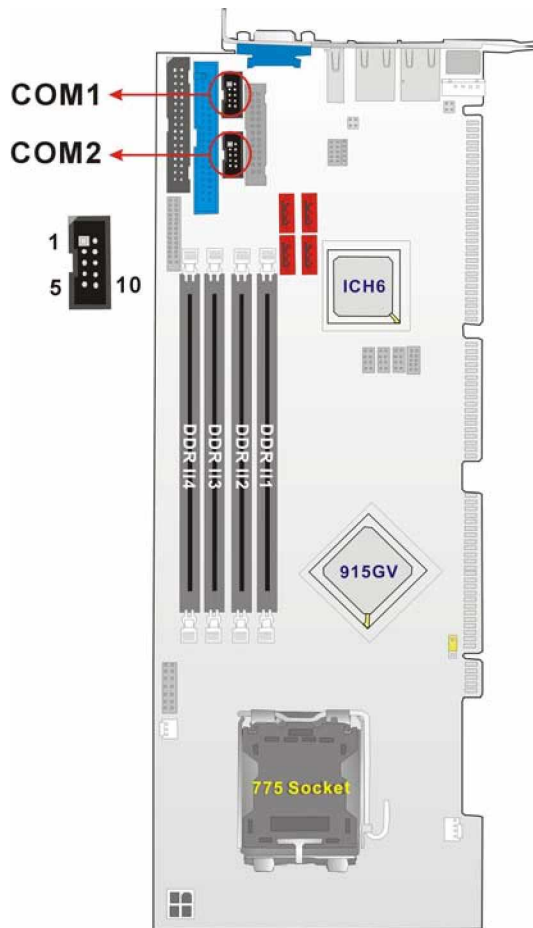

Figure 3-4: COM Port Locations

### 3.2.4 Parallel Port

CN Label: LPT1

CN Type: 2x13 pin header

**CN Location:** See Figure 3-5

**CN Pinouts:** See Table 3-4

The parallel port connector is usually connected to a printer. A 26-pin flat-cable connector is used to connect the parallel port with the printer or device to which the parallel port is connected.

PIN	DESCRIPTION	PIN	DESCRIPTION
1	STROBE#	14	AUTO FORM FEED #
2	DATA0	15	ERROR#
3	DATA1	16	INITIALIZE#
4	DATA2	17	PRINTER SELECT LN#
5	DATA3	18	GND
6	DATA4	19	GND
7	DATA5	20	GND
8	DATA6	21	GND
9	DATA7	22	GND
10	ACKNOWLEDGE#	23	GND
11	BUSY	24	GND
12	PAPER EMPTY	25	GND
13	PRINTER SELECT		

**Table 3-4: LPT Connector Pinouts**

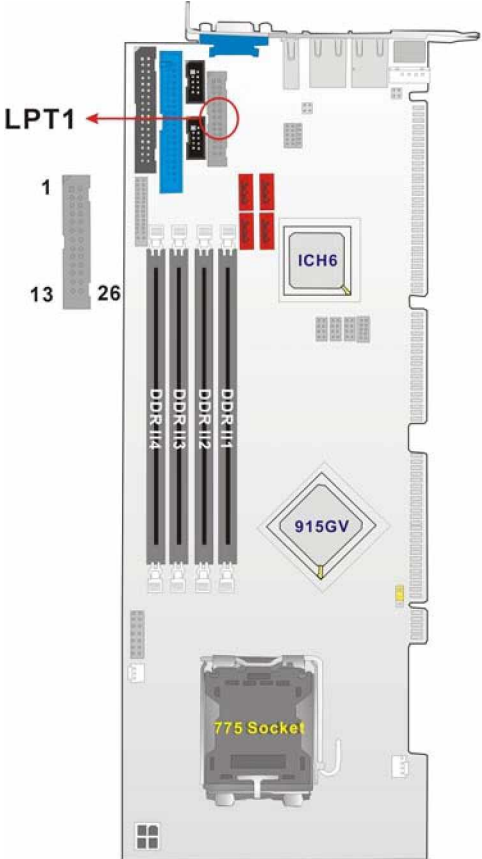

Figure 3-5: LPT Connector Location

3.2.5 DIO Connector

- CN Label:** DIO1
- CN Type:** 2x5 pin header
- CN Location:** See Figure 3-6
- CN Pinouts:** See Table 3-5 (DIO port Pinouts)

The digital input output (DIO) connector is managed through a Winbond W83628G LPC I/O chip. The DIO connector pins are user programmable.

PIN	DESCRIPTION	PIN	DESCRIPTION
1	Ground	2	VCC
3	Output 3	4	Output 2
5	Output 1	6	Output 0

7	Input 3	8	Input 2
9	Input 1	10	Input 0

Table 3-5: DIO Connector Pinouts

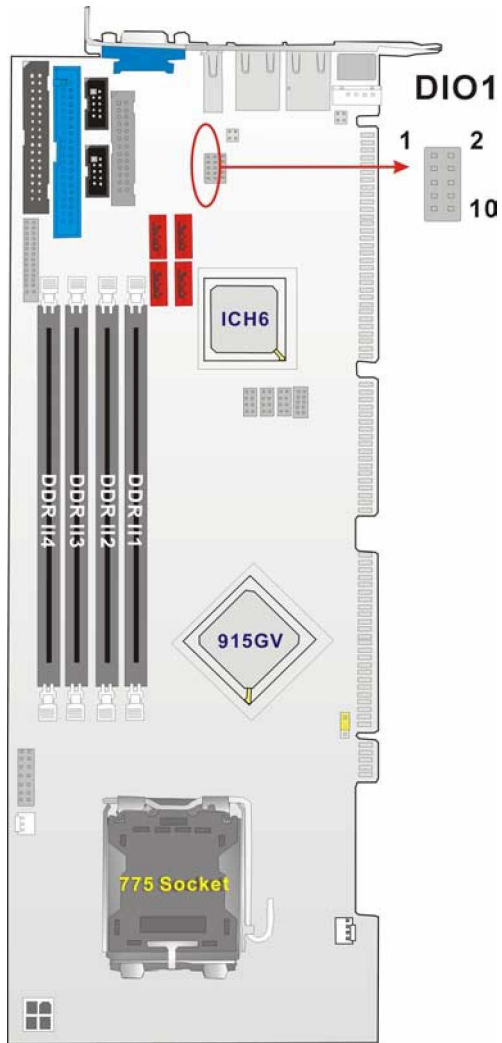

Figure 3-6: DIO Connector Location

### 3.2.6 Internal USB Connectors

**CN Label:** USB01, USB23, USB45

**CN Type:** 2x4 pin header

**CN Location:** See Figure 3-7

**CN Pinouts:** See Table 3-6

## 3301690 CPU Card

Three 2x4 pin connectors provide connectivity to six USB 2.0 ports. An additional USB port is found on the rear panel. The USB ports are used for I/O bus expansion and can be connected to peripheral USB devices.

PIN	DESCRIPTION	PIN	DESCRIPTION
1	VCC	2	GND
3	DATA-	4	DATA+
5	DATA+	6	DATA-
7	GND	8	VCC

Table 3-6: USB Port Connector Pinouts

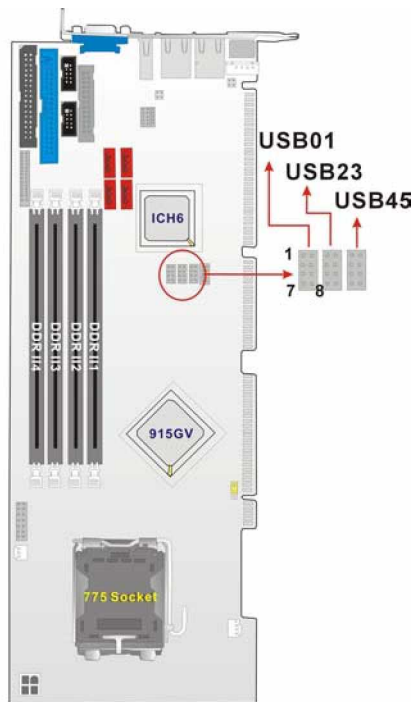

Figure 3-7: USB Port Connector Location

### 3.2.7 Cooling Fan

<b>CN Label:</b>	<b>CPU_FAN1</b>
<b>CN Type:</b>	<b>1x3 pin header</b>
<b>CN Location:</b>	<b>See Figure 3-8</b>
<b>CN Pinouts:</b>	<b>See Table 3-7</b>



The CPU\_FAN1 CPU cooling fan connector provides a 12V, 500mA current to the cooling fan. The connector has a "rotation" pin to get rotation signals from fans and notify the system so the system BIOS can recognize the fan speed. Please note that only specified fans can issue the rotation signals.

PIN	DESCRIPTION
1	Ground
2	+12V
3	Rotation Signal

Table 3-7: Cooling Fan Connector Pinouts

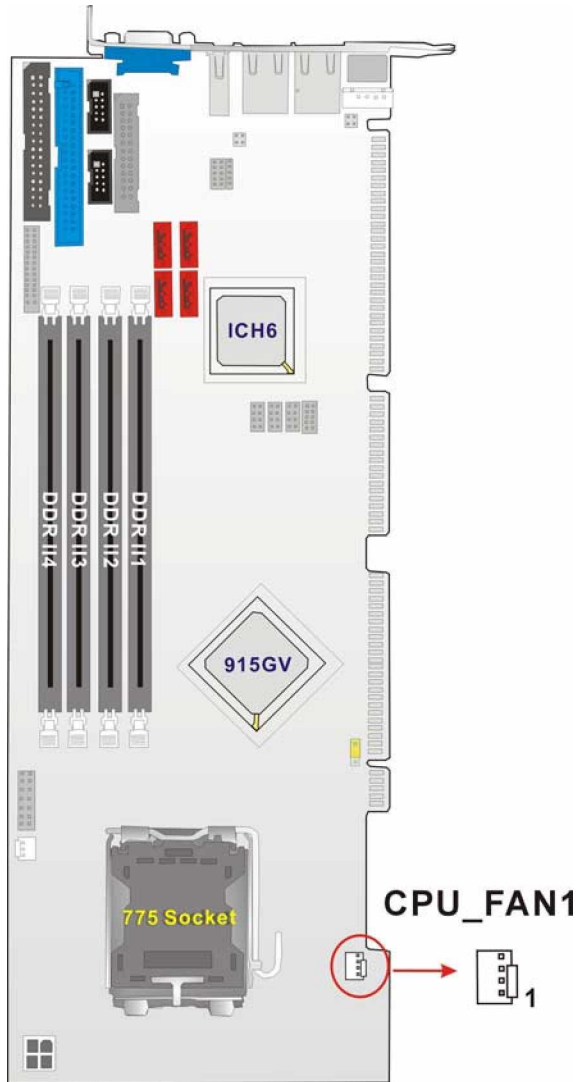

Figure 3-8: Cooling Fan Connector Locations

### 3.2.8 Backplane to Mainboard ATX Connector

- CN Label:** ATXCTL1
- CN Type:** 1x3 pin header
- CN Location:** See Figure 3-9
- CN Pinouts:** See Table 3-8

Connects a power source from a backplane with an ATX Connector.

PIN NO.	DESCRIPTION
1	GND
2	ATX-ON
3	5VSB

Table 3-8: ATXCTL1 Connector Pin Outs

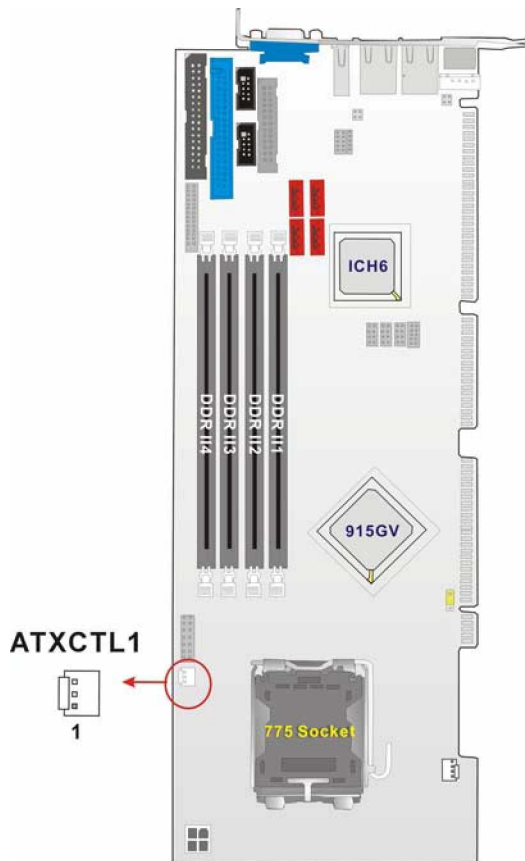

Figure 3-9: ATXCTL1 Connector Locations

### 3.2.9 System Front Panel Connector

- CN Label:** CN3
- CN Type:** 2x7 pin header
- CN Location:** See Figure 3-10
- CN Pinouts:** See Table 3-9

The system panel connector connects to:

- „ the system chassis front panel LEDs
- „ the chassis speaker
- „ the power switch
- „ the reset button.

PIN	DESCRIPTION	PIN	DESCRIPTION
1	+5V	2	SPEAKER+
3	N/C	4	N/C
5	GND	6	N/C
7	ATX PIN1	8	SPEAKER-
9	ATX PIN2	10	N/C
11	HDD LED+	12	RESET PIN1
13	HDD LED-	14	RESET PIN2

**Table 3-9: System Panel Connector Pinouts**

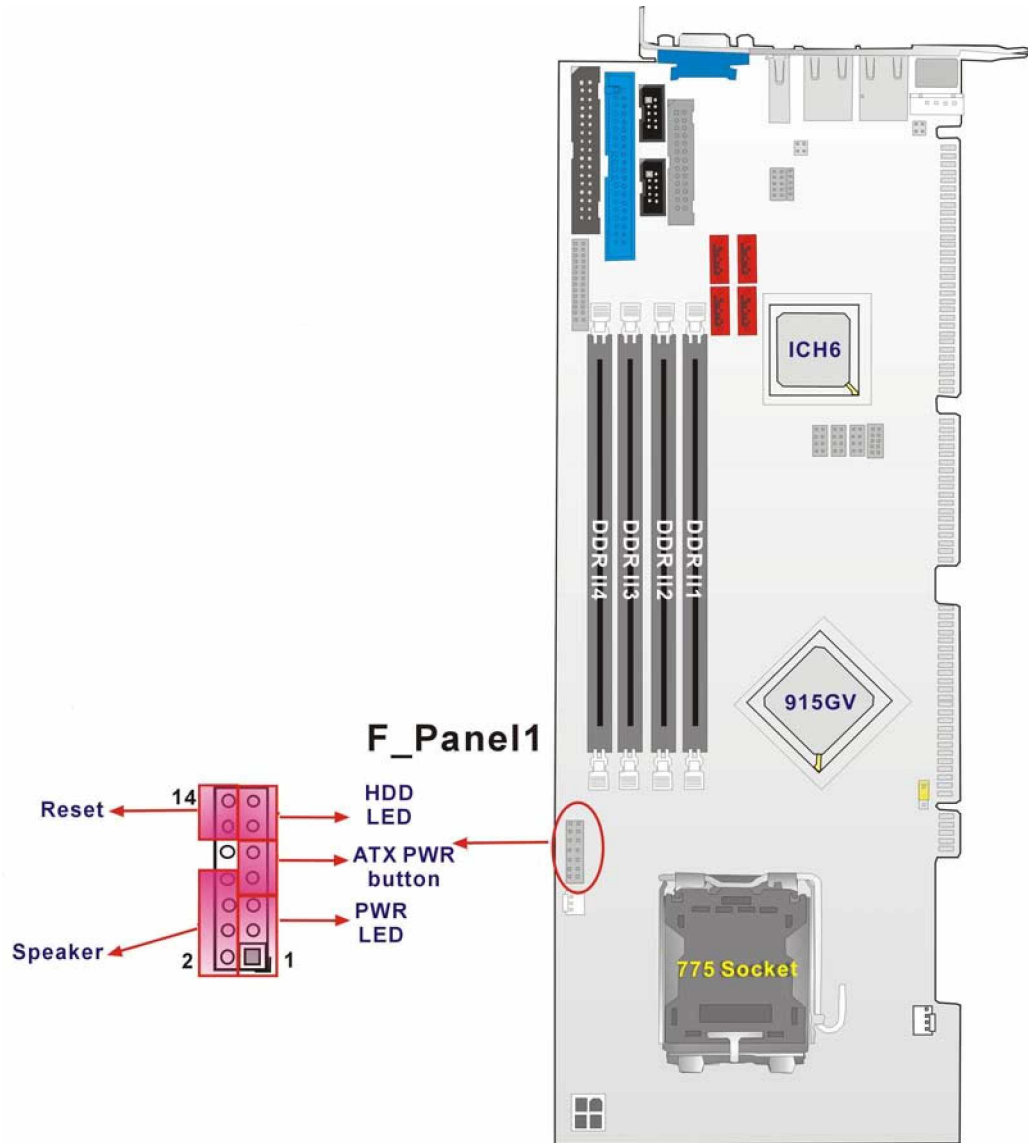

Figure 3-10: System Panel Connector Location

### 3.2.10 IrDA Connector

<b>CN Label:</b>	IR1
<b>CN Type:</b>	1x5 pin header
<b>CN Location:</b>	See Figure 3-11
<b>CN Pinouts:</b>	See Table 3-10

The integrated IrDA connector supports both the SIR and ASKIR infrared protocols.

PIN	DESCRIPTION
1	VCC
2	NC
3	IR-RX
4	GND
5	IR-TX

Table 3-10: IrDA Connector Pinouts

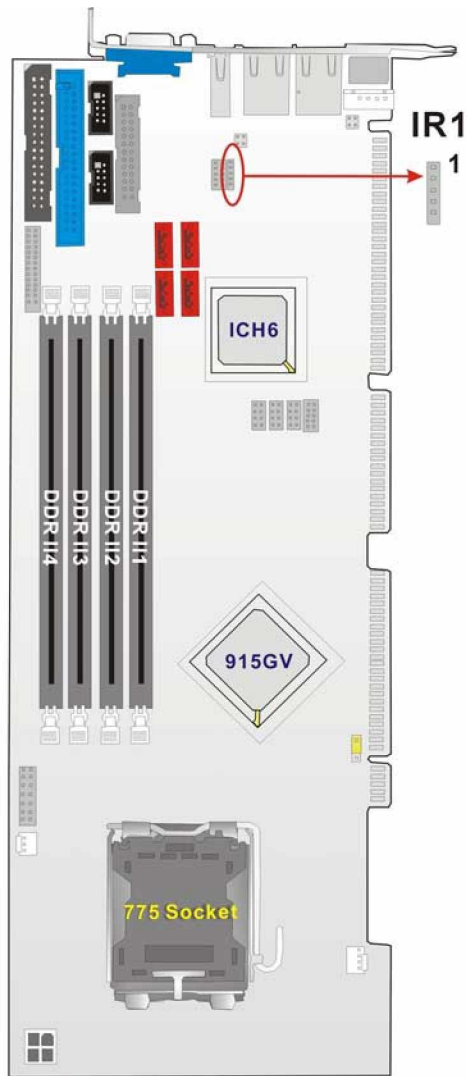

Figure 3-11: IrDA Connector Location

### 3.2.11 SATA Drive Connectors (CN14 & CN15)

**CN Label:** SATA1, SATA2, SATA3, SATA4

**CN Type:** 1x7 pin port

**CN Location:** See Figure 3-12

**CN Pinouts:** See Table 3-11

The SATA drive ports are connect to SATA HDDs with SATA signal cables. The maximum SATA data transfer rate supported is 150MB/s.

PIN	DESCRIPTION	PIN	DESCRIPTION
1	GND	5	RX-
2	TX+	6	RX+
3	TX-	7	GND
4	GND		

**Table 3-11: SATA Connector Pinouts**



#### **CAUTION!**

Your SATA hard drives may come with both a 4P power connector and a SATA power interface. Attach either the 4P connector or the included SATA power cable to your SATA hard drives. **DO NOT** attach both the power connectors to your SATA hard drives at the same time! Doing so will cause damage.

---

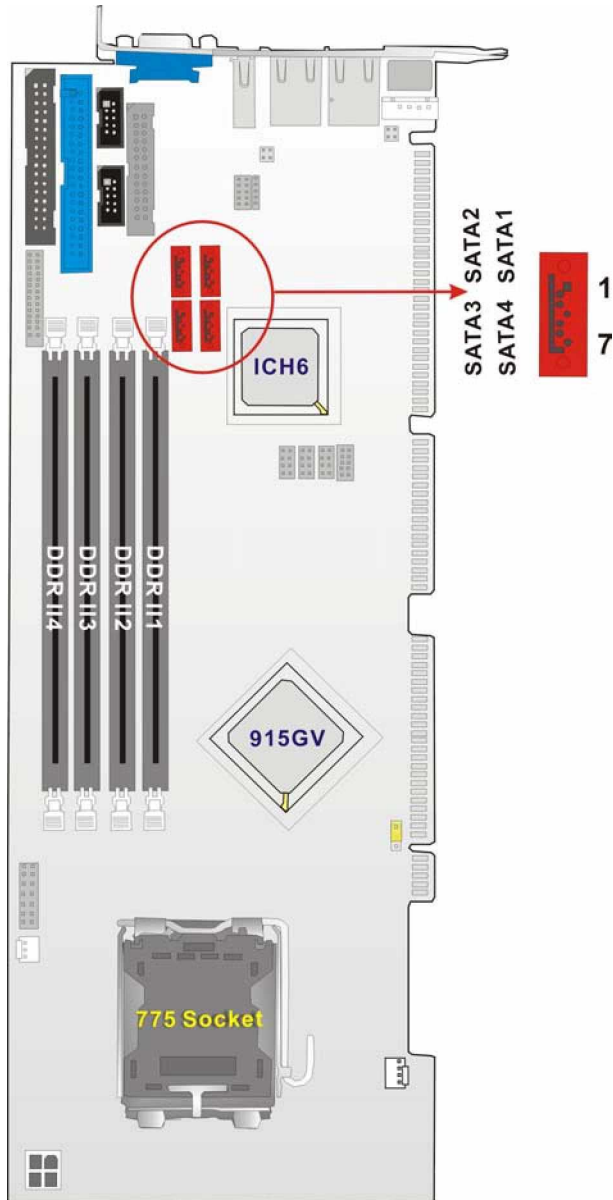

Figure 3-12: SATA Connector Locations



**NOTE:**

1. SATA is supported by:
  - Windows 2000 SP4
  - Windows XP SP1
  - Windows 2003, or later versions.
2. Older OSes, such as Windows 98SE or ME, do not support the SATA interface.

### 3.2.12 DVI (Digital Visual Interface) Connector

<b>CN Label:</b>	<b>DVI1</b>
<b>CN Type:</b>	<b>2x13 pin header</b>
<b>CN Location:</b>	<b>See Figure 3-13</b>
<b>CN Pinouts:</b>	<b>See Table 3-12</b>

The 3301690 CPU board provides a digital visual interface for digital display. Optional accessory IO-KIT-001 modules can be selected to connect to external DVI devices.

<b>PIN NO.</b>	<b>DESCRIPTION</b>	<b>PIN NO.</b>	<b>DESCRIPTION</b>
1	Data 2-	14	+5V Power
2	Data 2+	15	GND
3	GND	16	Hot Plug Detect.
4	N/C	17	Data 0-
5	N/C	18	Data 0+
6	DDC Clock	19	GND
7	DDC Data	20	N/C
8	N/C	21	N/C
9	Data 1-	22	GND
10	Data 1+	23	Clock +
11	GND	24	Clock -
12	N/C	25	GND
13	N/C		

**Table 3-12: DVI Connector Pinouts**



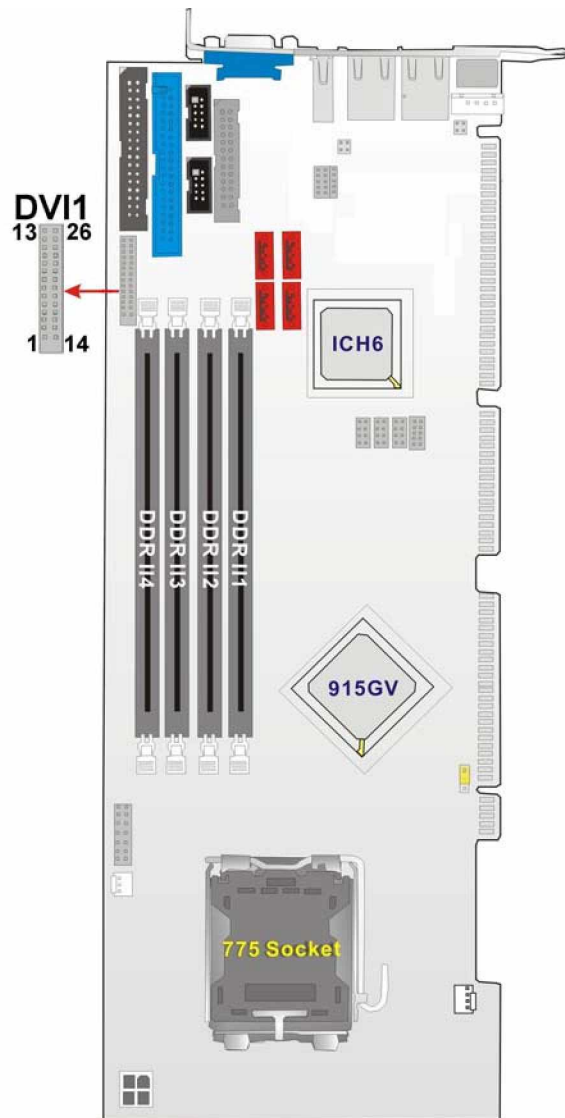

Figure 3-13: DVI1 Connector Location

### 3.2.13 LAN State LED Connector

CN Label:	DVI1
CN Type:	2x13 pin header
CN Location:	See Figure 3-14
CN Pinouts:	See Table 3-13

PIN NO.	DESCRIPTION
1	LED LINK 1000
2	LED LINK 10/100
3	LAN_LINK
4	ACT/LINK LED-Green

Table 3-13: J\_LANLED Connector Pinouts

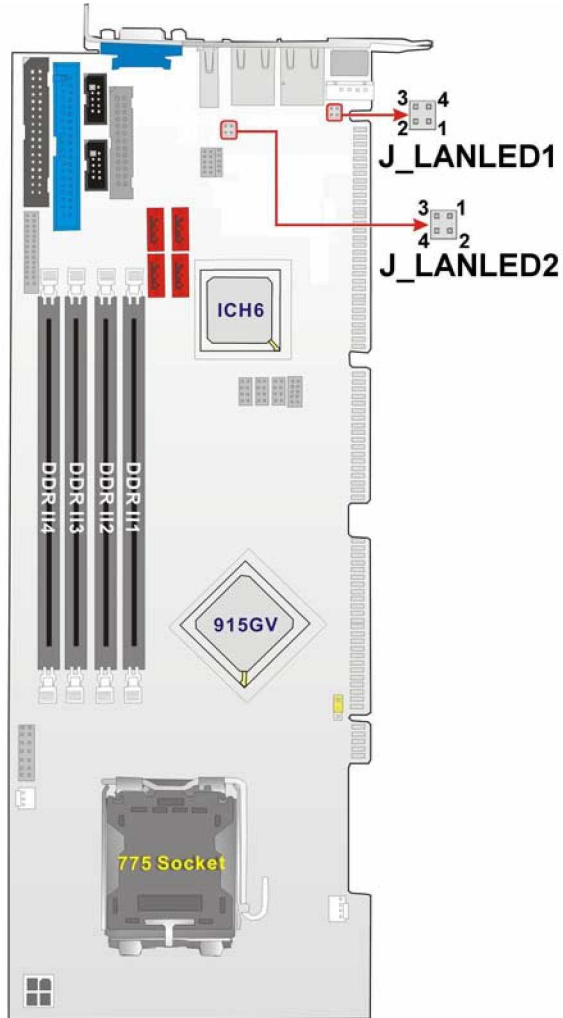

Figure 3-14: J\_LANLED Connector Locations

### 3.2.14 AC'97 Connector

- CN Label:** J\_AUDIO1
- CN Type:** 2x5 pin header
- CN Location:** See Figure 3-15
- CN Pinouts:** See Table 3-14

The 3301690 CPU board does not have a built-in AC'97 AUDIO CODEC. If your system needs audio then this connector must be connected to an external audio CODEC module.

PIN NO.	DESCRIPTION	PIN NO.	DESCRIPTION
1	SYNC	2	BITCLK
3	SDOUT	4	PCBEEP
5	SDIN	6	RST#
7	VCC	8	GND
9	+12V		

**Table 3-14: J\_AUDIO1 Connector Pinouts**

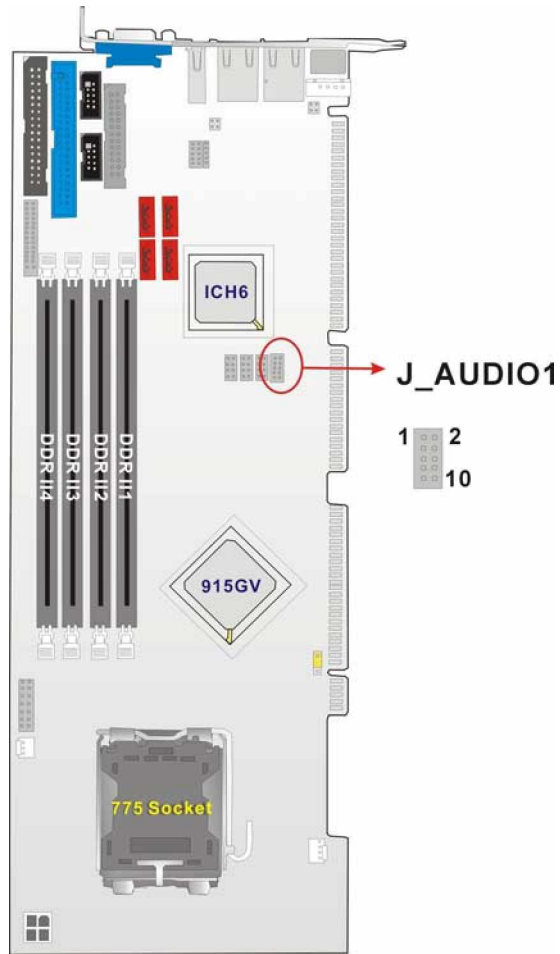

Figure 3-15: J\_AUDIO Connector Location

### 3.2.15 Keyboard Connector

<b>CN Label:</b>	<b>KB1</b>
<b>CN Type:</b>	<b>2x13 pin header</b>
<b>CN Location:</b>	<b>See Figure 3-16</b>
<b>CN Pinouts:</b>	<b>See Table 3-15</b>

For alternative application, a keyboard pin header connector is also available on board.

PIN NO.	DESCRIPTION
1	KEYBOARD CLOCK
2	KEYBOARD DATA
3	N/C
4	GND
5	VCC

Table 3-15: KB1 Connector Pinouts

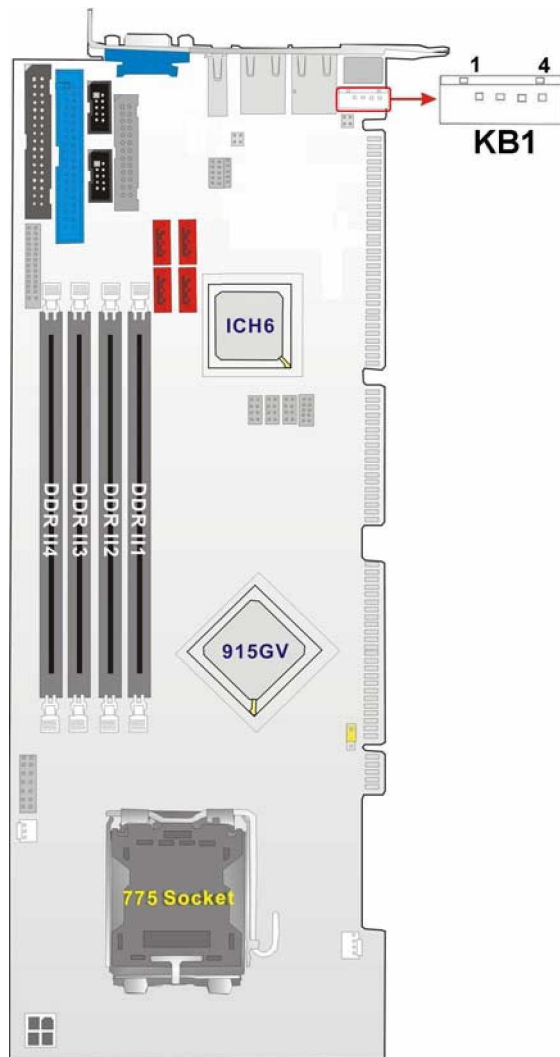

Figure 3-16: KB1 Connector Location

### 3.2.16 ATX-12V Power Source Connector

- CN Label:** CPU12V
- CN Type:** 2x13 pin header
- CN Location:** See Figure 3-17
- CN Pinouts:** See Table 3-16

This connector supports the ATX-12V power supply.

PIN NO.	DESCRIPTION	PIN NO.	DESCRIPTION
1	GND	2	GND
3	+12V	4	+12V

**Table 3-16: ATX Connector Pinouts**

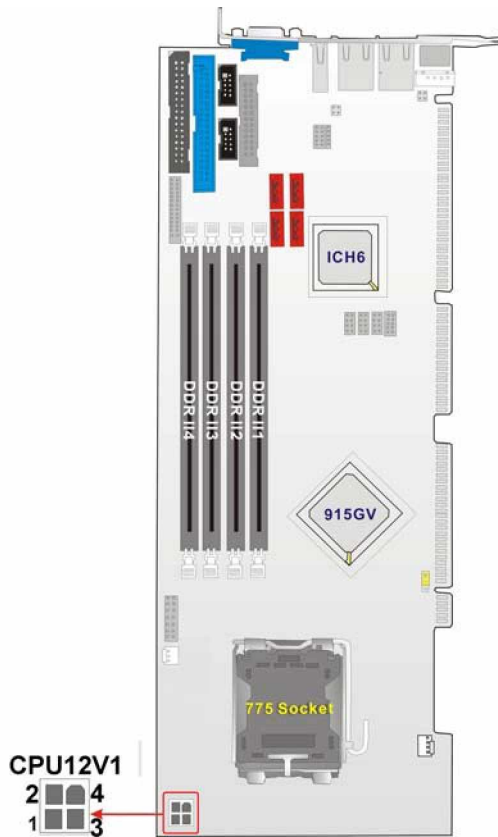

**Figure 3-17: ATX Connector Location**

### 3.3 External (Rear Panel) Connectors

Figure 3-18 shows the 3301690 CPU board rear panel. The peripheral connectors on the back panel can be connected to devices externally when the CPU card is installed in a chassis. The peripheral connectors on the rear panel are:

- „ 1 x PS/2 keyboard connector
- „ 1 x USB connectors
- „ 2 x GbE connectors
- „ 1 x VGA connector
- „ 2 x RJ-45 Ethernet connectors

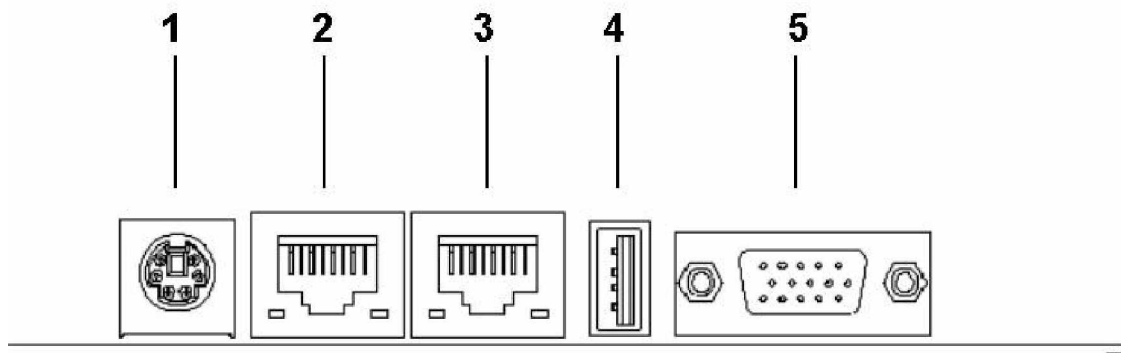

Figure 3-18: 3301690 CPU Board Rear Panel

#### 3.3.1 PS/2 Connector

**CN Label:** KB\_MS1

**CN Type:** PS/2

**CN Location:** See Figure 3-18 (labeled number 1)

**CN Pinouts:** See Table 3-17

Figure 3-19 shows PS/2 pin-out locations

The PS/2 mouse and keyboard connectors are connected to a mouse and keyboard

PIN	DESCRIPTION		DESCRIPTION
1	KB Data	2	N/C
3	GND	4	+5V
5	Clock	6	N/C

**Table 3-17: PS/2 Pinouts**

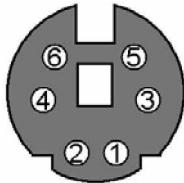

**Figure 3-19: PS/2 Pin-out locations**

### 3.3.2 USB Connector

- CN Label:** USB
- CN Type:** USB port
- CN Location:** See **Figure 3-18** (labeled number 2)
- CN Pinouts:** See **Table 3-18**

USB devices can be connected directly to the USB connectors on the rear panel.

PIN	DESCRIPTION	PIN	
1	+5V	2	DATA-
3	DATA+	4	GND

**Table 3-18: USB Connectors**

### 3.3.3 Ethernet Connector

- CN Label:** LAN1, LAN2
- CN Type:** RJ-45
- CN Location:** See **Figure 3-18** (labeled number 5)
- CN Pinouts:** See **Table 3-19**



Two gigabit connections can be made between the Ethernet connectors and a Local Area Network (LAN) through a network hub. An RJ-45 Ethernet connector is shown in **Figure 3-20**.

PIN	DESCRIPTION	PIN	DESCRIPTION
1	TXD+	8	GND
2	TXD-	9	GRN+
3	RXD+	10	GRN-
4	CT_TXD	11	YEL-
5	CT_RXD	12	YEL+
6	RXD-	13	S GND
7	N/C	14	S GND

**Table 3-19: RJ-45 Ethernet Connector Pinouts**

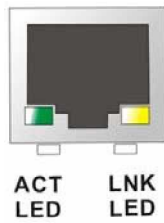

**Figure 3-20: RJ-45 Ethernet Connector**

The RJ-45 Ethernet connector has two status LEDs, one red and one yellow. The green LED indicates activity on the port and the yellow LED indicates that the port is linked. See **Table 3-20**.

STATUS	DESCRIPTION	STATUS	
GREEN	Activity	YELLOW	Linked

**Table 3-20: RJ-45 Ethernet Connector LEDs**

### 3.3.4 VGA Connector

**CN Label:** VGA1

**CN Type:** 15-pin

**CN Location:** See **Figure 3-18** (labeled number 7)

The standard 15-pin VGA connector connects to a CRT or LCD display monitor.

PIN	DESCRIPTION	PIN	DESCRIPTION
1	Red	9	No Connect
2	Green	10	Ground
3	Blue	11	No Connect
4	No Connect	12	DDC DAT
5	Ground	13	Horizontal Synchronization
6	Ground	14	Vertical Synchronization
7	Ground	15	DDC Clock
8	Ground		

**Table 3-21: VGA Connector Pinouts**

### 3.4 Onboard Jumpers



**NOTE:**

A jumper is a metal bridge that is used to close an electrical circuit. It consists of two metal pins and a small metal clip (often protected by a plastic cover) that slides over the pins to connect them. To CLOSE/SHORT a jumper means connecting the pins of the jumper with the plastic clip and to OPEN a jumper means removing the plastic clip from a jumper.

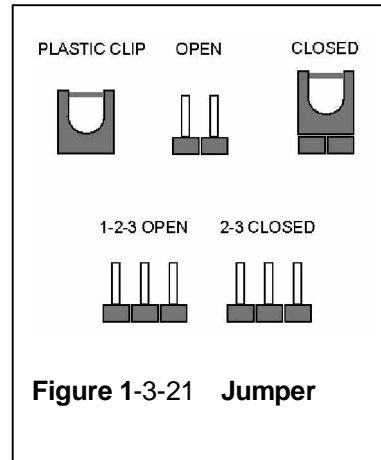

The 3301690 CPU Board has one onboard jumper. The jumper is described in **Table 3-22**.

Label	Purpose		pe
J_CMOS1	Reset CMOS	Resets the CMOS	3-pin

**Table 3-22: Jumpers**

### 3.4.1 Reset CMOS Jumper

- Jumper Label:** J\_CMOS1
- Jumper Type:** 3 pin header
- Jumper Settings:** See **Table 3-23**
- Jumper Location:** See **Figure 3-22**

If the CPU Card fails to boot due to improper BIOS setting, use this jumper to clear the CMOS data and reset the system BIOS information. To do this, use the jumper cap to close pins 2 and 3 for a few seconds then reinstall the jumper clip back to pins 1 and 2.

If the “CMOS Settings Wrong” message displays during the boot up process, you may then try to correct the fault by pressing the F1 to enter the CMOS Setup menu. You may then do one of the following:

- „ Enter the correct CMOS setting
- „ Load Optimal Defaults
- „ Load Failsafe Defaults.

After you have done one of the above, save your changes and exit the CMOS Setup menu.

JP1	CLEAR CMOS
1-2 closed	Normal (default)
2-3 closed	CLEAR CMOS

**Table 3-23: J\_CMOS1 Jumper Settings**

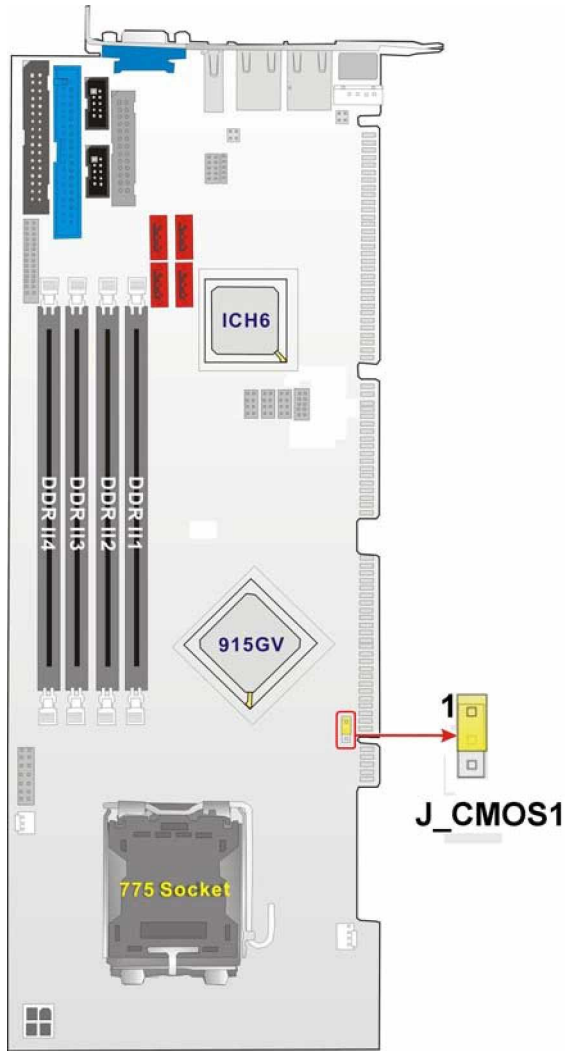

Figure 3-22: J\_CMOS1 Jumper Location

Chapter

4

# 4 Installation and Configuration

---

## 4.1 Installation Considerations

---



### NOTE:

The following installation notices and installation considerations should be read and understood before the CPU card is installed. All installation notices pertaining to the installation of the CPU card should be strictly adhered to. Failing to adhere to these precautions may lead to severe damage of the CPU card and injury to the person installing the CPU card.

---

### 4.1.1 Installation Notices

Before and during the installation of the 3301690 CPU Board CPU Card, please **do** the following:

- „ Read the user manual  
The user manual provides a complete description of the 3301690 CPU Board, installation instructions and configuration options.
- „ Wear an electrostatic discharge cuff (ESD)  
Electronic components are easily damaged by ESD. Wearing an ESD cuff will remove ESD from your body and help to prevent ESD damage.
- „ Place the CPU Card on an antistatic pad:  
When you are installing or configuring the CPU Card, place it on an antistatic pad. This will help to prevent potential ESD damage.
- „ Turn off all power to the 3301690 CPU card  
When working with the CPU card, make sure that it is disconnected from all power supplies and that no electricity is being fed into the system.

Before and during the installation of the 3301690 CPU Board **DO NOT:**

- „ remove any of the stickers on the PCB board. These stickers are required for

- warranty validation.
- „ use the product before you have verified that all cables and power connectors are properly connected.
- „ allow screws to come in contact with the PCB circuit, connector pins, or its components.

## 4.2 Unpacking

---



### NOTE:

If any of the items listed below are missing when you unpack the 3301690 CPU card, do not proceed with the installation and contact the reseller or vendor you purchased the CPU card from.

---

### 4.2.1 Unpacking Precautions

Before you install the 3301690 CPU card, you must unpack the CPU card. Some components on 3301690 are very sensitive to static electricity and can be damaged by a sudden rush of power. To protect it from being damage, follow these precautions:

- „ Ground yourself to remove any static charge before touching your 3301690. You can do so by wearing a grounded wrist strap at all times or by frequently touching any conducting materials that is connected to the ground.
- „ Handle your 3301690 by its edges. Do not touch the IC chips, leads or circuitry if not necessary.

Do not place a PCB on top of an anti-static bag. Only the inside of the bag is safe from static discharge.

### 4.2.2 Checklist

When you unpack the 3301690, please make sure that your package contains the following items.

- „ 1 x 3301690 system host board computer

## 3301690 CPU Card

- „ 1 x mini jumper pack
- „ 1 x ATA 66/100 flat cable
- „ 2 x SATA cable
- „ 1 x SATA power cable
- „ 1 x Keyboard/ PS2 mouse Y cable
- „ 1 x RS-232 cable
- „ 1 x USB cable
- „ 1 x Utility CD
- „ 1 x QIG (quick installation guide)

If one or more of these items are missing, please contact the reseller or vendor you purchased the 3301690 CPU card from and do not proceed any further with the installation.

### 4.3 3301690 CPU Card Installation

---



#### **WARNING!**

1. Never run the CPU board without an appropriate heatsink and cooler that can be ordered from GAI or purchased separately.
  2. Be sure to use CPU 12V power connector for the CPU power.
- 



#### **WARNING!**

Please note that the installation instructions described in this manual should be carefully followed in order to avoid damage to the CPU Card components and injury to you.

---





### **WARNING!**

When installing electronic components onto the CPU Card always take the following anti-static precautions in order to prevent ESD damage to your board and other electronic components like the CPU and DIMM modules

---

The following components must be installed onto the CPU Card or connected to the CPU Card during the installation process.

- „ CPU
- „ CPU cooling kit
- „ DIMM modules
- „ Peripheral device connection

### **4.3.1 CPU Installation**

#### **4.3.1.1 CPU Selection: HT Functionality Requirements**

Enabling Hyper-Threading Technology on your system requires meeting all of the platform requirements listed below:

- „ CPU: An Intel® Pentium 4 Processor with HT Technology must be installed
- „ Chipset: An Intel® Chipset that supports HT Technology (that has been met by the 3301690)
- „ OS: An operating system that has optimizations for HT Technology

#### **4.3.1.2 CPU Installation**



### **WARNING!**

CPUs are expensive and sensitive components. When you install the CPU please be careful not to damage it in anyway. Make sure you install it properly and ensure that a heatsink and CPU cooling fan is properly installed before you run the CPU Card or else both the CPU and the board will be damaged.

---

The LGA775 socket is shown in **Figure 4-1**.

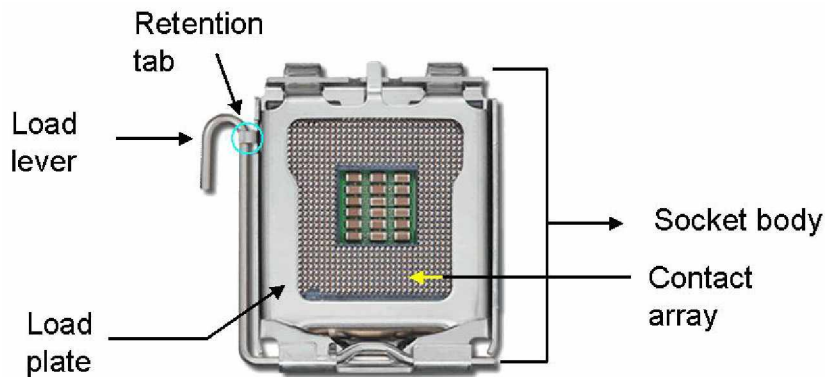

**Figure 4-1: Intel LGA775 Socket**

To install Intel LGA775 socket CPU onto your CPU Card, follow the steps below:

**Step 1: Remove the protective cover.** Remove the black protective cover by prying it off the load plate. The protective cover is used to protect the delicate pins on the LGA775 socket. To remove the protective cover, locate the “**REMOVE**” sign and use your fingernail to pry the protective cover off. (See **Figure 4-2**)

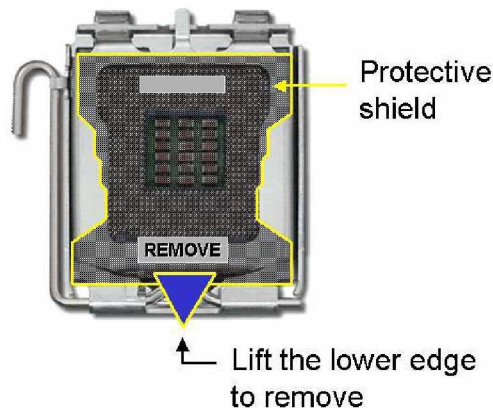

**Figure 4-2: Remove the CPU Socket Protective Shield**

**Step 2: Open the socket.** To open the socket, disengage the load lever by pressing the lever down and slightly outward to clear the retention tab. Rotate the load lever to a fully open position. Then rotate the load plate towards the opposite direction. (See **Figure 4-3**)

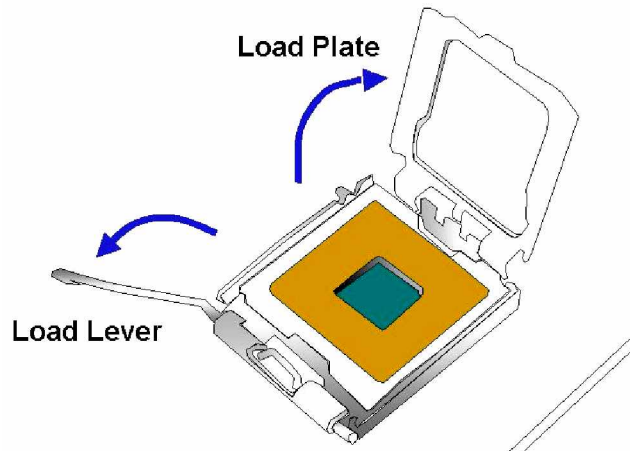
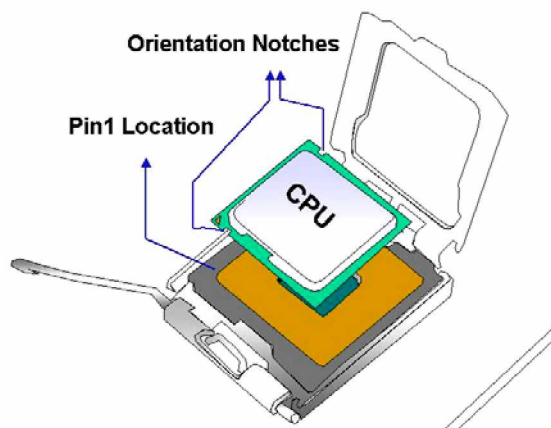

**Figure 4-3: Open the CPU Socket Load Plate**

**Step 3: Inspect the CPU and the socket.** Make sure that the pins on the CPU are not bent. Also make sure socket contacts are free of foreign material. If you see any debris in the socket remove it using compressed air.

**Step 4: Insert the 775-pin CPU.** To insert the CPU refer to **Figure 4-4** and follow the five steps below.

1. Hold the CPU by the LGA edges marked by back lines.
2. Orient the CPU with the IHS (Integrated Heat Sink) side facing upward.
3. Locate pin 1 and the two orientation notches on the CPU.
4. Carefully match the two orientation notches on the CPU with the alignment keys of the socket.
5. Carefully place the CPU into the socket with a gentle and vertical motion.



**Figure 4-4: Insert the CPU**

**Step 5: Close the CPU socket.** Close the load plate and engage the load lever by pushing it back to its original position. Secure the load lever under the retention tab on the side of CPU socket.

**Step 6: After the cooling kit is installed** (see **Section 4.3.2**), connect the CPU cable to the CPU 12V power connector. Step 0:

### 4.3.2 Cooling Kit (CF-520) Installation

---



#### **WARNING!**

**It is strongly recommended that you DO NOT use the original heatsink and cooler provided by Intel on the 3301690.**

The CPU board is vertically mounted on a horizontal backplane, and Intel's heatsink does not come with a support bracket on the soldering side, the PCB may be bent by the weight of the cooling kit.

The cooling kit includes a support bracket that is combined with the heatsink mounted on the CPU to counterweigh and balance the load on both sides of the PCB.

---



**Figure 4-5: Cooling Kit**

The LGA775 CPU cooling kit shown in **Figure 4-5** comprises a CPU heatsink and a cooling fan.

 **CAUTION:**

The heatsink has a layer of thermal paste sprayed on the lower surface. Do not accidentally wipe the thermal paste away when you unpack or install the heatsink. Thermal paste between the CPU and the heatsink is important for optimal heat dissipation.

To install the cooling kit, follow the instructions below.

- Step 1:** Place the heatsink onto the socket. Make sure that the CPU cable can be properly routed when the heatsink is installed.
- Step 2:** Align the heatsink so that its fourspring screw fasteners can pass through the pre-drilled holes on the PCB.
- Step 3:** From the other side of the PCB, align the support bracket to the screw threads on heatsink that were inserted through the PCB holes.

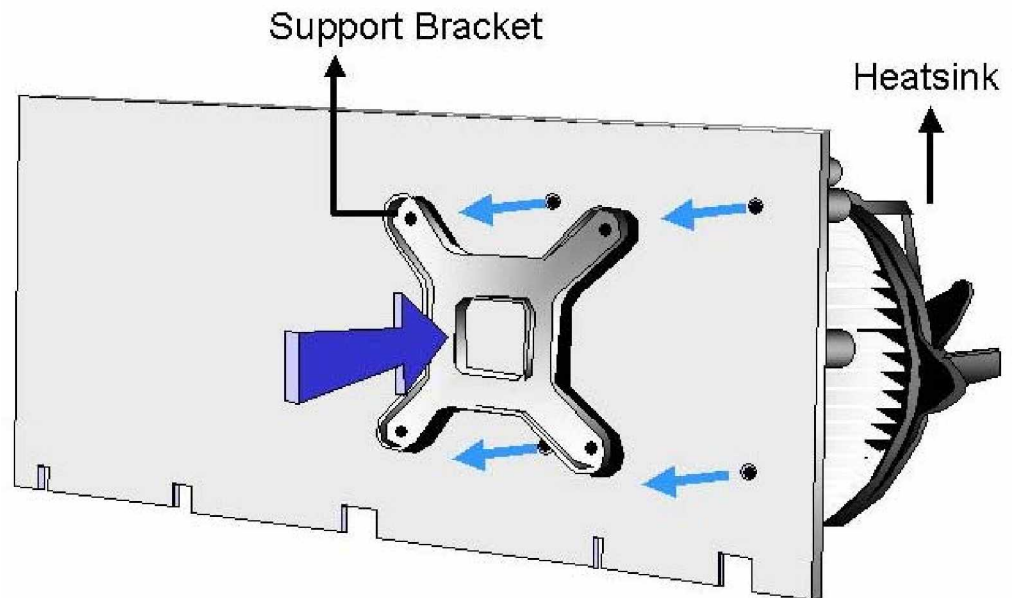

**Figure 4-6: Securing the heatsink to the PCB board**

- Step 4:** Use the screwdriver to tighten the four screws. Tighten each nut a few turns at a time and do not over-tighten the screws.

**Step 5:** Connect the fan cable on the cooler fan to the CPU fan connector on the CPU card. Make sure the fan cable does not touch any heat generating chips and fan blades. Step 0:

### 4.3.3 DIMM Module Installation

#### 4.3.3.1 Purchasing the Memory Module



#### **WARNING!**

The DDR2 architecture is not compatible with DDR1 modules. If your system is installed with DDR1 modules, damage might occur and you will not be able to boot up your system.

---

When you purchase your DIMM modules, the following considerations should be taken into account:

- „ Each DIMM module can support a memory chip with a maximum size of 1GB
- „ Dual Channel mode will not be enabled if only one DDR2 memory module is installed. DIMMs must be installed in pairs
- „ Only use DDR2 memory chips in the DIMM slots
- „ It is recommended that you use memory modules of identical brand, size, chips, and speed.
- „ DIMMs must use the same density memory chips
- „ Both DIMMs must use the same DRAM bus width
- „ Both DIMMs must be either single-sided or dual-sided.

#### 4.3.3.2 Memory Configuration Rules

The 3301690 CPU card has four DIMM modules named as follows (refer to **Figure 4-7**)

- „ Channel A: DDR II 1.
- „ Channel A: DDR II 2.
- „ Channel B: DDR II 3.
- „ Channel B: DDR II 4.

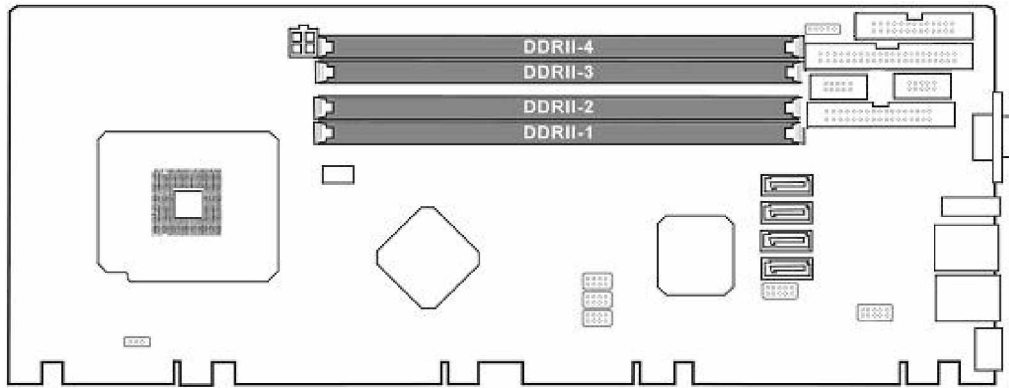

Figure 4-7: DIMM Sockets

#### 4.3.3.3 DIMM Module Configurations



#### CAUTION:

Please adhere to the precautions and configuration options listed in this section. Failure to adhere to these precautions may lead to CPU card damage.

- „ **DO NOT** install three memory modules on three DIMM slots. Doing so will result in unpredictable failures.
- „ If only one memory module is installed, install it into the first DIMM slot, i.e., DDRII 1.
- „ Dual-channel DDR only works in the combinations listed in **Table 4-1**.

DDRII 1 (Ch A)	DDRII 2 (Ch A)	DDRII 3 (Ch B)	DDRII 4 (Ch B)	Total Capacity
256MB~1GB				256MB~1GB
256MB~1GB		256MB~1GB		512MB~2GB
	256MB~1GB		256MB~1GB	512MB~2GB
256MB~1GB	256MB~1GB	256MB~1GB	256MB~1GB	1GB~4GB

Table 4-1: Dual Memory Channel Configuration Options

#### 4.3.3.4 DIMM Module Installation

The 3301690 CPU Board has two DDRII SDRAM DIMM sockets. To install the DIMM modules, follow the instructions below.

- Step 1:** Pull the two white handles on either side of the DIMM socket down.
- Step 2:** Align the DIMM module with the DIMM socket making sure the matching pins are correctly aligned.
- Step 3:** Insert the DIMM module slowly. Once you are sure it is correctly inserted, push down firmly. The white handles on either side of the socket will move back up and lock the module into the socket. Step 0:

#### 4.3.4 Peripheral Device Connection

Cables provided by GAI that connect peripheral devices to the CPU Card are listed in **Table 4-2**. Cables not included in the kit must be separately purchased.

Quantity	pe
1	ATA 66/100 flat cable
2	SATA cables
1	SATA power cable
1	Keyboard/ PS2 mouse Y cable
1	RS-232 cable
1	USB cable

**Table 4-2: Provided Cables**

##### 4.3.4.1 IDE Disk Drive Connector (IDE1)

The cable used to connect the CPU card to the IDE HDD is a standard 44-pin ATA 66/100 flat cable. To connect an IDE HDD to the CPU Card, follow the instructions below.

- Step 1:** Find the ATA 66/100 flat cable in the kit that came with the CPU Card.
- Step 2:** Connect one end of the cable to the IDE1 connector on the CPU card. A keyed pin on the IDE connectors prevents it from being connected incorrectly.



**Step 3:** Locate the red wire on the other side of the cable that corresponds to the pin 1 connector.

**Step 4:** Connect the other side of the cable to the HDD making sure that the pin 1 cable corresponds to pin 1 on the connector. Step 0:

---



### **NOTE:**

When two EIDE disk drives are connected together, back-end jumpers on the drives must be used to configure one drive as a master and the other as a slave.

---

#### **4.3.4.2 Floppy Drive Connector (FDD1)**

This connector provides access to two externally mounted 3.5" floppy drives. To connect the CPU Card to a FDD, follow the instructions below.

**Step 1:** Insert one side of the cable into the FDC making sure that the red wire on the cable corresponds to pin one on the connector.

**Step 2:** Attach the connector on the other side of the cable to the floppy drive(s). You can only use one connector in the set. The connection sequence determines which of the two connected floppy drives is drive A: and which is drive B. Step 0:

### **4.4 Chassis Installation**

After the CPU, the cooling kit, and the DIMM modules have been installed and after the internal peripheral connectors have been connected to the peripheral devices and the jumpers have been configured, the CPU Card can be mounted into chassis.

To mount the CPU Card into a chassis please refer to the chassis user guide that came with the product.

## **4.5 Rear Panel Connectors**

### **4.5.1 LCD Panel Connection (VGA1 )**

The conventional CRT monitor connector, VGA1, is a 15-pin, female D-SUB connector. Pin assignments can be seen in that can be connected to external monitors.

### **4.5.2 Ethernet Connection (LAN1 and LAN2)**

The rear panel RJ-45 connectors can be connected to an external LAN and communicate with data transfer rates up to 1Gb/s.

### **4.5.3 USB Connection (USB\_C6)**

The rear panel USB connector provides easier and quicker access to external USB devices. The rear panel USB connector is a standard connector and can easily be connected to other USB devices.

Chapter

**5**

# **5 AMI BIOS Setup**

---

## 5.1 Introduction

A licensed copy of AMI BIOS is preprogrammed into the ROM BIOS. The BIOS setup program allows users to modify the basic system configuration. This chapter describes how to access the BIOS setup program and the configuration options you may change.

### 5.1.1 Starting Setup

The AMI BIOS is activated when you turn on the computer. The setup program can be activated in one of two ways.

1. Press the **DELETE** key as soon as the system is turned on or
2. Press the **DELETE** key when the “**Press Del to enter SETUP**” message appears on the screen.

If the message disappears before you respond, you must restart your computer and try again.

### 5.1.2 Using Setup

Use the arrow keys to highlight items, press **ENTER** to select, use the PageUp and PageDown keys to change entries, press **F1** for help and press **Esc** to quit. Navigation keys are shown in.

Key	Function
Up arrow	Move to previous item
Down arrow	Move to next item
Left arrow	Move to the item on the left hand side
Right arrow	Move to the item on the right hand side
Esc key	Main Menu – Quit and not save changes into CMOS Status Page Setup Menu and Option Page Setup Menu -- Exit current page and return to Main Menu
Page Up key	Increase the numeric value or make changes
Page Dn key	Decrease the numeric value or make changes
F1 key	General help, only for Status Page Setup Menu and Option Page Setup Menu

F2 /F3 key	Change color from total 16 colors. F2 to select color forward.
F10 key	Save all the CMOS changes, only for Main Menu

**Table 5-1: BIOS Navigation Keys**

### 5.1.3 Getting Help

When you press **F1** a small help window describing the appropriate keys to use and the possible selections for the highlighted item appears. To exit the Help Window press **Esc** or the **F1** key again.

### 5.1.4 Unable to Reboot After Configuration Changes

If you are unable to boot your computer after you have made changes to the system configuration, you must restore the CMOS defaults. Use the jumper described in Chapter **Chapter 3, Section 3.4.1**.

### 5.1.5 BIOS Menu Bar

The **menu bar** on top of the BIOS screen has the following main items:

- „ **Main** Changes the basic system configuration.
- „ **Advanced** Changes the advanced system settings.
- „ **PCIPnP** Changes the advanced PCI/PnP Settings
- „ **Boot** Changes the system boot configuration.
- „ **Security** Sets User and Supervisor Passwords.
- „ **Chipset** Changes the chipset settings.
- „ **Power Key** Changes power management settings.
- „ **Exit** Selects exit options and loads default settings

The following sections will completely describe the configuration options found in the menu items at the top of the BIOS screen and listed above.

## 5.2 Main

When you enter the BIOS Setup program, the **Main** menu (**BIOS Menu 1**) appears. The Main menu gives you an overview of the basic system information.

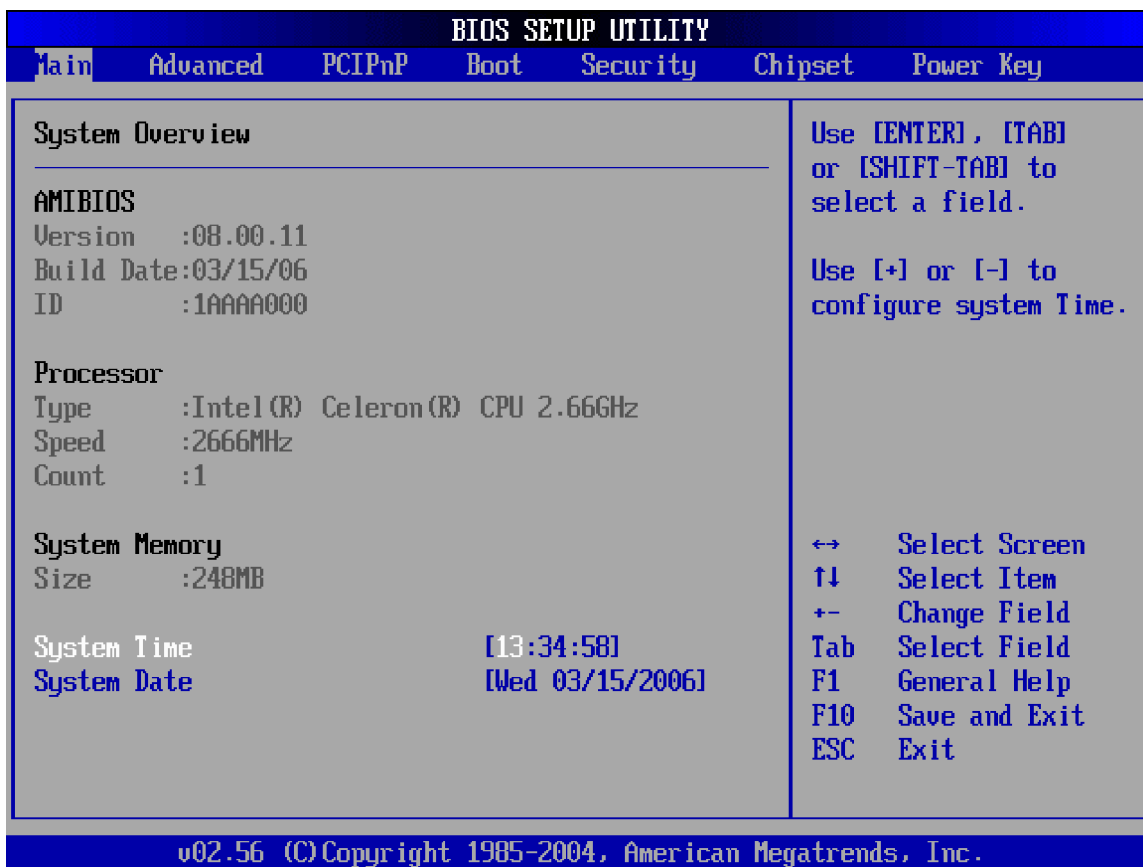

### BIOS Menu 1: Main

#### System Overview

The **System Overview** lists a brief summary of different system components. The fields in **System Overview** cannot be changed. The items shown in the system overview include:

- „ **AMI BIOS:** Displays auto-detected BIOS information
  - „ Version: Current BIOS version
  - „ Build Date: Date the current BIOS version was made

- „ ID: Installed BIOS ID
  
- „ **Processor:** Displays auto-detected CPU specifications
  - „ Type: Names the currently installed processor
  - „ Speed: Lists the processor speed
  - „ Count: The number of CPUs on the CPU board
  
- „ **System Memory:** Displays the auto-detected system memory.
  - „ Size: Lists memory size

The System Overview field also has two user configurable fields:

- „ System Time [xx:xx:xx]: Allows you to set the system time.
- „ System Date [Day xx/xx/xxxx]: Allows you to set the system date.

### 5.3 Advanced

The **Advanced** menu (**BIOS Menu 2**) allows you to access CPU and peripheral device configuration options.



## BIOS Menu 2: Advanced

### 5.3.1 CPU Configuration

The **CPU Configuration** menu (**BIOS Menu 3**) shows detailed CPU specifications and CPU configuration options.



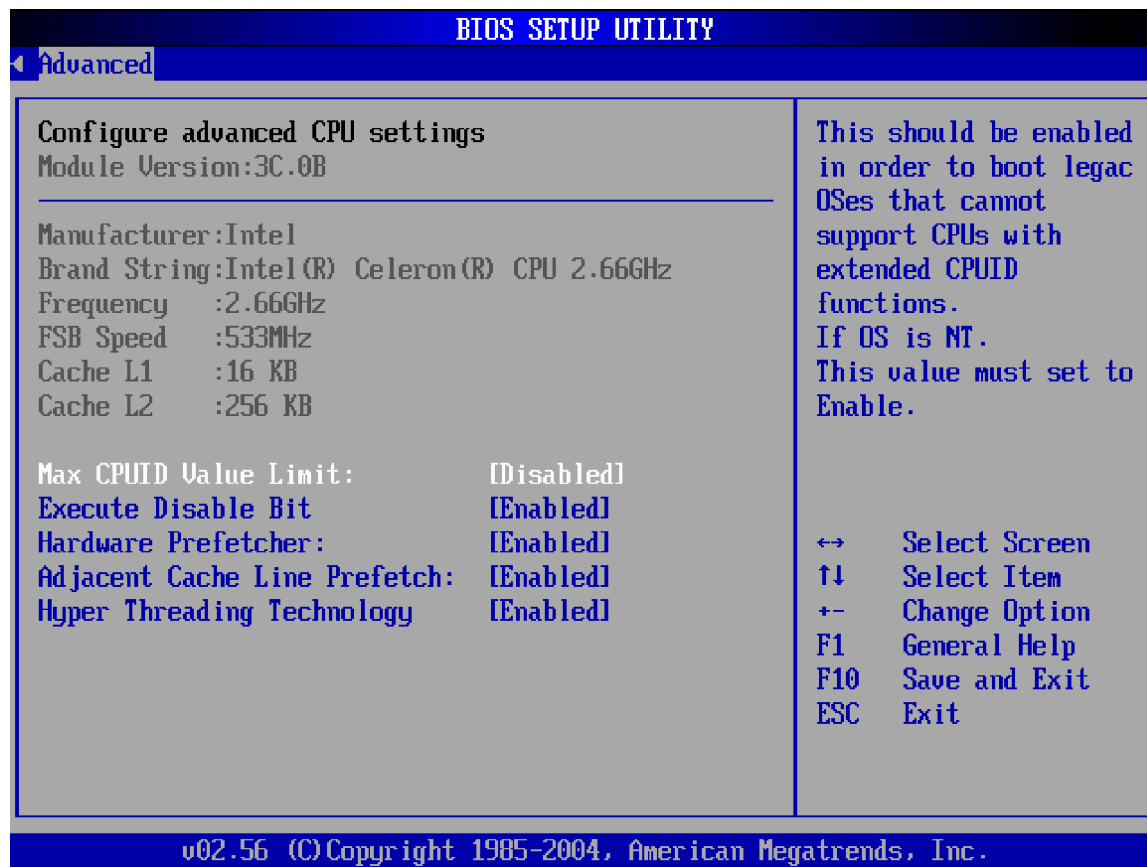

### BIOS Menu 3: CPU Configuration [Advanced]

The CPU Configuration menu (**BIOS Menu 3**) lists the following CPU details:

- „ **Manufacturer:** Lists the name of the CPU manufacturer
- „ **Brand String:** Lists the brand name of the CPU being used
- „ **Frequency:** Lists the CPU processing speed
- „ **FSB Speed:** Lists the FSB speed
- „ **Cache L1:** Lists the CPU L1 cache size
- „ **Cache L2:** Lists the CPU L2 cache size

The following **CPU Configuration** menu items can be configured.

- „ Max CUPID Value Limit
- „ Execute Disable Bit
- „ Hardware Prefetcher
- „ Adjacent Cache Line Prefetch

„ Hyper Threading Technology

## ↑ Max CUPID Value Limit [Disabled]

---



### NOTE:

If your OS is NT, this value must be set to enabled.

---



**Disabled** (DEFAULT) Disables legacy OSes that cannot support CPUs with extended CUPID functions from booting up



**Enabled** Enables legacy OSes that cannot support CPUs with extended CUPID functions to boot up

## ↑ Execute Disable Bit [Enabled]

The **Enhanced Intel SpeedStep Technology** (EIST) function allows the CPU to lower its internal frequency when the workload is light.



**Disabled** Forces the XD feature flag to always return to 0



**Enabled** (DEFAULT) Does not force the XD feature flag to return to 0

## ↑ Hardware Prefetcher [Enabled]



**Disabled** Does not allow the Hardware Prefetcher Disable feature to be enabled or disabled.



**Enabled** (DEFAULT) Allows the Hardware Prefetcher Disable feature to be either enabled or disabled

## ↑ Adjacent Cache Line Prefetch [Enabled]



**Disabled** Does not allow the Adjacent Cache Line Prefetch Disable feature to be enabled or disabled

 **Enabled** (DEFAULT) Allows the Adjacent Cache Line Prefetch Disable feature to be either enabled or disabled

 **Hyper Threading Technology [Disabled]**

 **Disabled** (DEFAULT) Disables the use of hyper threading technology

 **Enabled** Enables the use of hyper threading technology

### 5.3.2 IDE Configuration

The IDE Configuration menu (**BIOS Menu 4**) allows you to set or change the configurations for the IDE devices installed in the system.

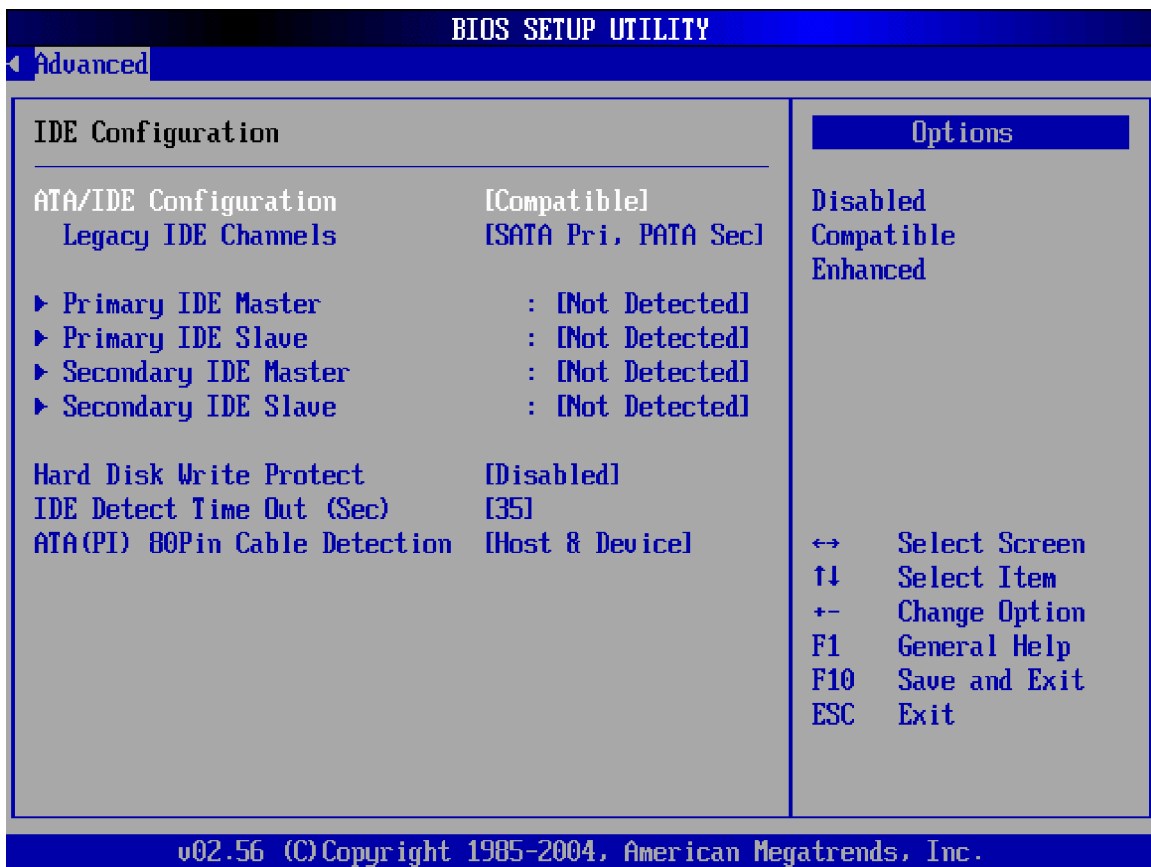

**BIOS Menu 4: IDE Configuration [Advanced]**

## ⌄ ATA/IDE Configuration [Compatible]

- ⌄ Disabled
- ⌄ **Compatible** (DEFAULT)
- ⌄ Enhanced

## ⌄ Legacy IDE Channels

- ⌄ SATA Only
- ⌄ PATA Pri, SATA Sec
- ⌄ **SATA Pri, PATA Sec** (DEFAULT)
- ⌄ PATA Only

## ⌄ IDE Master and IDE Slave

When entering setup, BIOS auto detects the presence of IDE devices. This displays the status of the auto detected IDE devices. The following IDE devices will be detected and are shown in the **IDE Configuration** menu:

- „ Primary IDE Master
- „ Primary IDE Slave
- „ Secondary IDE Master
- „ Secondary IDE Slave

The IDE Configuration menu (**BIOS Menu 4**) allows you to set or change the configurations for the IDE devices installed in the system. If an IDE device is detected, and one of the above listed four BIOS configuration options are selected, the IDE configuration options shown in **Section 5.3.2.1** appear.

## ⌄ Hard Disk Write Protect [Disabled]

- ⌄ **Disabled** (DEFAULT) Disables device write protection
- ⌄ **Enabled** Enables device write protection

Note that the selection in this menu item will only be effective if the device is accessed through the BIOS.

**↑ IDE Detect Time Out (Sec)**

**IDE Detect Time Out (Sec)** allows you to select the timeout value for detecting ATA/ATAPI devices. The default **[35]** is recommended. The timeout value options are:

- „ 0
- „ 5
- „ 10
- „ 15
- „ 20
- „ 25
- „ 30
- „ 35 (Default)

**↑ ATA (PI) 80Pin Cable Detection [Host & Device]**

- ↑ Host & Device** (DEFAULT) Uses the host and device to detect the 80-pin ATA(PI) cable
- ↑ Host** Uses the host to detect the 80-pin ATA(PI) cable
- ↑ Device** Uses the device to detect the 80-pin ATA(PI) cable

**5.3.2.1 IDE Master and IDE Slave**

IDE Master and IDE Slave configuration options for both primary and secondary IDE devices are shown in the BIOS menu below.

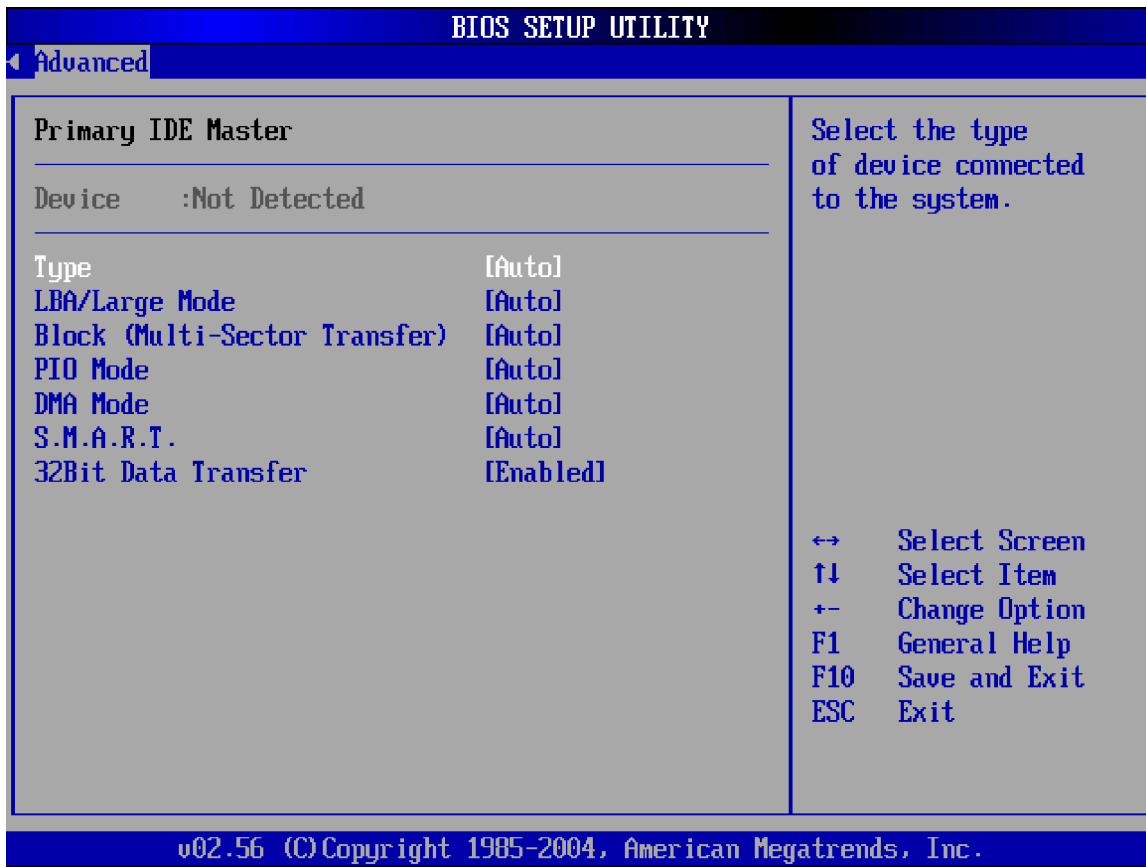

**BIOS Menu 5: IDE Master and IDE Slave Configuration [Advanced/IDE Configuration]**

- ↑ **Type [Auto]**

  - ↑ **Not Installed** BIOS specifies that no IDE device is installed
  - ↑ **Auto (DEFAULT)** BIOS automatically detects the IDE device ↑
  - CD/DVD** The IDE device is declared to be a CD/DVD
  - ↑ **ARMD** The IDE device is declared to be an ARMD (ATAPI Removable Media Device)
  
- ↑ **LBA/Large Mode [Auto]**

  - ↑ **Disabled** Disables LBA mode
  - ↑ **Auto (DEFAULT)** Enables LBA mode if the device supports it but has

not been formatted with LBA mode disabled

**Block (Multi Sector Transfer) [Auto]**

- Disabled** The data transfer from the device occurs one sector at a time
- Auto (DEFAULT)** Data transfer to and from the device occurs multi sectors at a time if the device supports it

**PIO Mode [Auto]**

The following PIO mode options are available:

- „ Auto (DEFAULT)
- „ 0
- „ 1
- „ 2
- „ 3
- „ 4

**DMA Mode [Auto]**

The DMA mode is automatically detected by the BIOS

**S.M.A.R.T [Auto]**

- Auto (DEFAULT)** S.M.A.R.T (Self Monitoring Analysis and Reporting Technology) is automatically detected.
- Disabled** S.M.A.R.T is disabled
- Enabled** S.M.A.R.T is enabled

**32Bit Data Transfer [Enabled]**

- Disabled** Disables 32-bit data transfer
- Enabled (DEFAULT)** Enables 32-bit data transfer

### 5.3.3 Floppy Configuration

The **Floppy Configuration** menu (**BIOS Menu 6**) determines the type of floppy drive installed in the system. The Floppy Configuration menu has two configurable items: Floppy A and Floppy B. Both Floppy A and Floppy B have the same configuration options listed below.

- „ Disabled
- „ 360KB, 5.25 in
- „ 1.2MB, 5.25 in
- „ 720KB, 3.5 in
- „ 1.44MB, 3.5 in
- „ 2.88MB, 3.5in



BIOS Menu 6: Floppy Configuration [Advanced]



### 5.3.4 Super IO Configuration

The **Super IO Configuration** menu (**BIOS Menu 7**) allows you to set or change the configurations for the FDD controllers, parallel ports and serial ports.

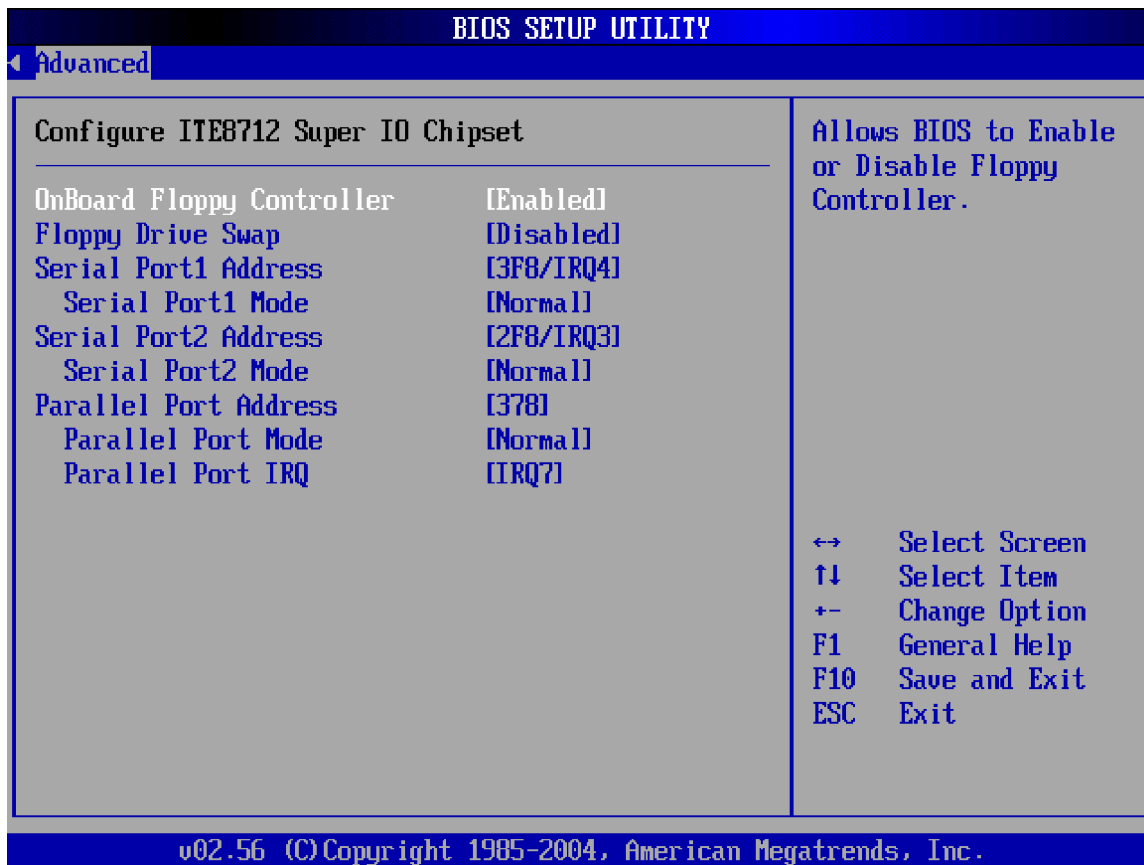

#### BIOS Menu 7: Super IO Configuration [Advanced]

##### ↑ On Board Floppy Controller [Enabled]

- ↑ Disabled Allows BIOS to disable the floppy controller
- ↑ Enabled (DEFAULT) Allows BIOS to enable the floppy controller

##### ↑ Floppy Drive Swap [Disabled]

- ↑ Disabled (DEFAULT) Cannot designate A or B to a floppy drive without changing the physical connection

 **Enabled** Can designate A or B to a floppy drive without changing the physical connection

 **Serial Port1 Address [3F8/IRQ4]**

This option allows BIOS to select the base addresses for Serial Port 1

 **Disabled** No base address is assigned to Serial Port 1

 **3F8/IRQ4** (DEFAULT) Serial Port 1 base address is 3F8/IRQ4



 **3E8/IRQ4** Serial Port 1 base address is 3E8/IRQ4

 **2E8/IRQ3** Serial Port 1 base address is 2E8/IRQ3

 **Serial Port1 Mode [Normal]**

Allows BIOS to select the mode for Serial Port 1

 **Normal** (DEFAULT) Serial Port 1 mode is normal

 **IrDA** Serial Port 1 mode is IrDA 

**ASK IR** Serial Port 1 mode is ASK IR

 **Serial Port2 Address [2F8/IRQ3]**

This option allows BIOS to select the base addresses for Serial Port 2

 **Disabled** No base address is assigned to Serial Port 2

 **2F8/IRQ3** (DEFAULT) Serial Port 1 base address is 2F8/IRQ3

 **3E8/IRQ4** Serial Port 1 base address is 2F8/IRQ3

 **2E8/IRQ3** Serial Port 1 base address is 2F8/IRQ3

 **Serial Port2 Mode [Normal]**

Allows BIOS to select the mode for Serial Port 2

- ↑ **Normal** (DEFAULT) Serial Port 1 mode is normal
- ↑ **IrDA** Serial Port 1 mode is IrDA ↑
- ASK IR** Serial Port 1 mode is ASK IR

#### ↑ **Parallel Port Address [Disabled]**

This option allows BIOS to select the base addresses for the Parallel Port

- ↑ **Disabled** (DEFAULT) No base address is assigned to the Parallel Port
- ↑ **378** Parallel Port base address is 378
- ↑ **278** Parallel Port base address is 278
- ↑ **3BC** Parallel Port base address is 3BC

### 5.3.5 Hardware Health Configuration

The **Hardware Health Configuration** menu (**BIOS Menu 8**) allows you to change the configuration for the H/W Health Function and shows you the operating temperature, fan speeds and system voltages.

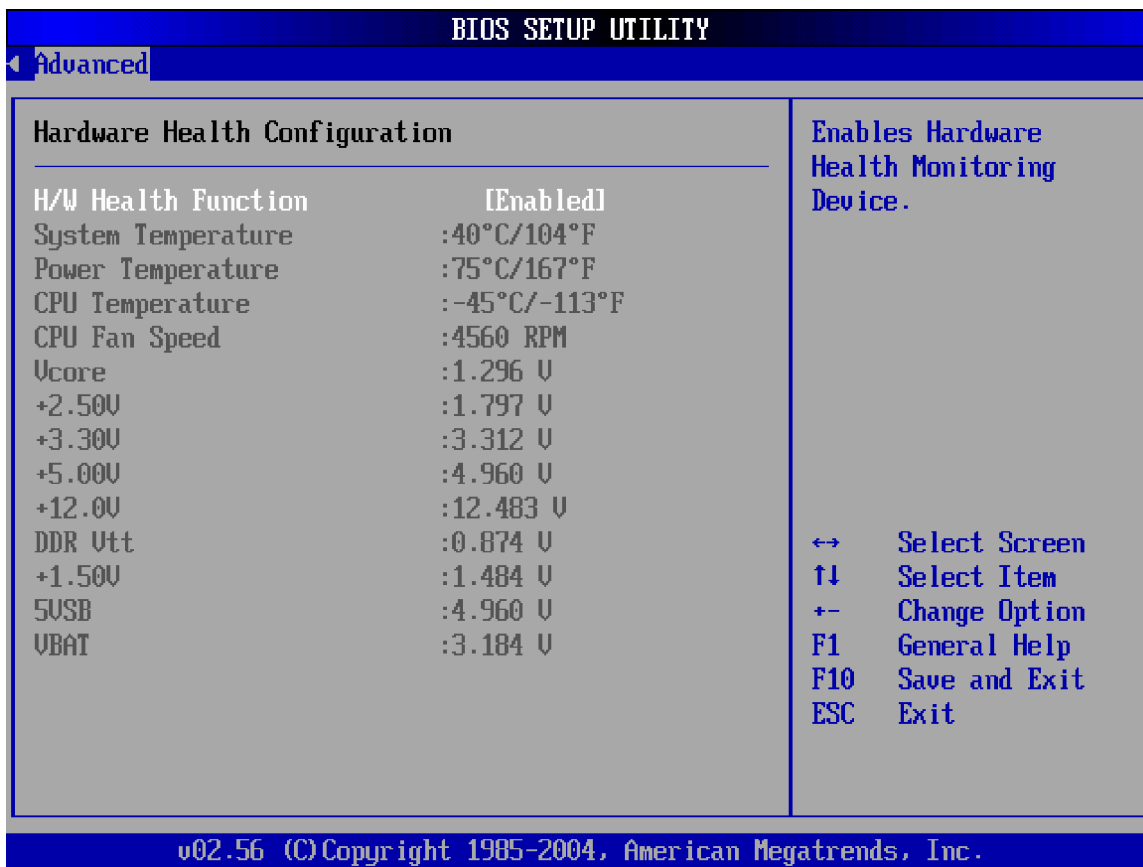

### BIOS Menu 8: Hardware Health Configuration [Advanced]

#### ↑ H/W Health Function [Enabled]

↑ Disabled Disables the health monitoring function

↑ Enabled (DEFAULT) Enables the health monitoring function

If the **H/W Health Function** is enabled different system parameters and values are shown.

The system parameters that are monitored are:

- „ **System Temperatures:** The following system temperatures are monitored
  - „ System Temperature:
  - „ Power Temperature
  - „ CPU Temperature
- „ **Fan Speeds:** The CPU cooling fan speed is monitored.

- „ CPU Fan Speed

- „ **Voltages:** The following system voltages are monitored

- „ Vcore
- „ +2.50V
- „ +3.30V
- „ +5.00V
- „ +12.0V
- „ DDR Vtt
- „ +1.50V
- „ 5VSB
- „ VBAT

### 5.3.6 ACPI Configuration

The **ACPI Configuration** menu (**BIOS Menu 9**) allows you to configure the Advanced Configuration and Power Interface (ACPI) and Power Management (APM) options.

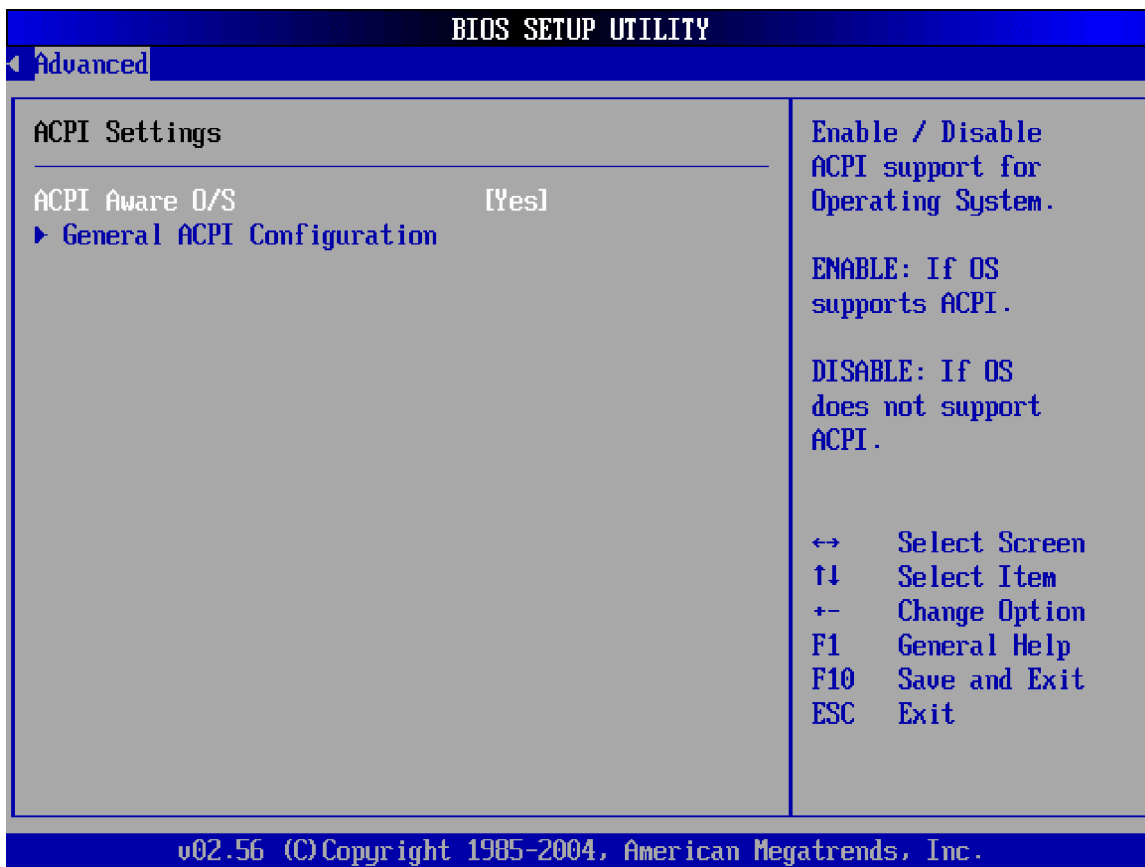

### BIOS Menu 9: ACPI Configuration [Advanced]

#### ↑ ACPI Aware O/S [Yes]

**ACPI Aware O/S** can only be configured if your OS complies with the ACPI standard. Windows 98, Windows 2000, and Windows XP all comply with ACPI.

↑ **No** Disables the ACPI support for the OS. This selection should be disabled if the OS does not support ACPI

↑ **Yes (DEFAULT)** Enables the ACPI support for the operating system. This selection should be enabled if the OS does support ACPI

### 5.3.6.1 General ACPI Configuration

The General ACPI Configuration menu (**BIOS Menu 10**) allows you to select the ACPI state when the system is suspended.

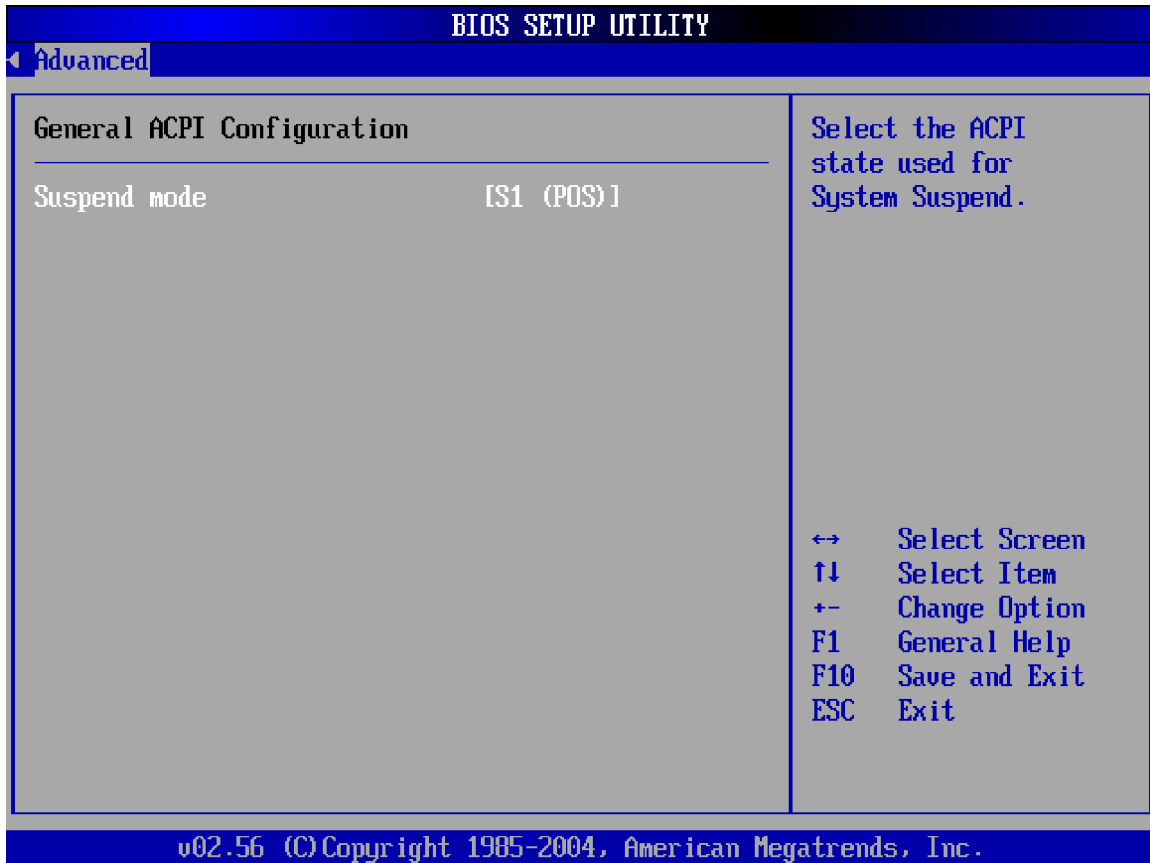

#### BIOS Menu 10: General ACPI Configuration [Advanced\ ACPI Configuration]

- ↑ Suspend Mode [S1(POS)]
  - ↑ S1 (POS) (DEFAULT) S1 (POS) is selected as the ACPI state for System Suspend
  - ↑ S3 (STR) S3 (STR) is selected as the ACPI state for System Suspend

### 5.3.7 MPS Configuration

The MPS Configuration menu (**BIOS Menu 11**) allows you to configure the multi-processor table.

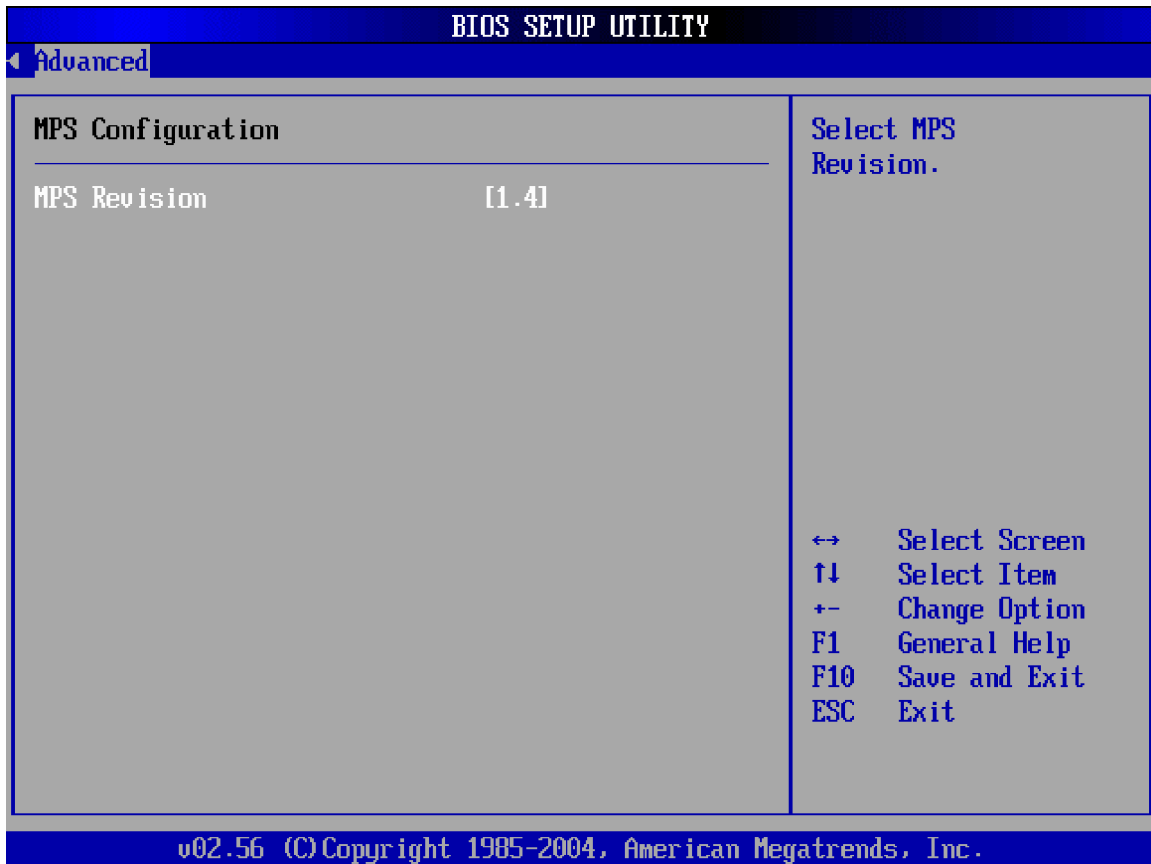

### BIOS Menu 11: MPS Configuration [Advanced]

#### ↑ MPS Revision

The following configuration options are available

- .. 1.1(Default)
- .. 1.4

### 5.3.8 Remote Access Configuration

The **Remote Access Configuration** menu (**BIOS Menu 12**) allows you to configure remote access parameters. The **Remote Access Configuration** is an AMIBIOS feature



and allows a remote host running a terminal program to display and configure the BIOS settings.

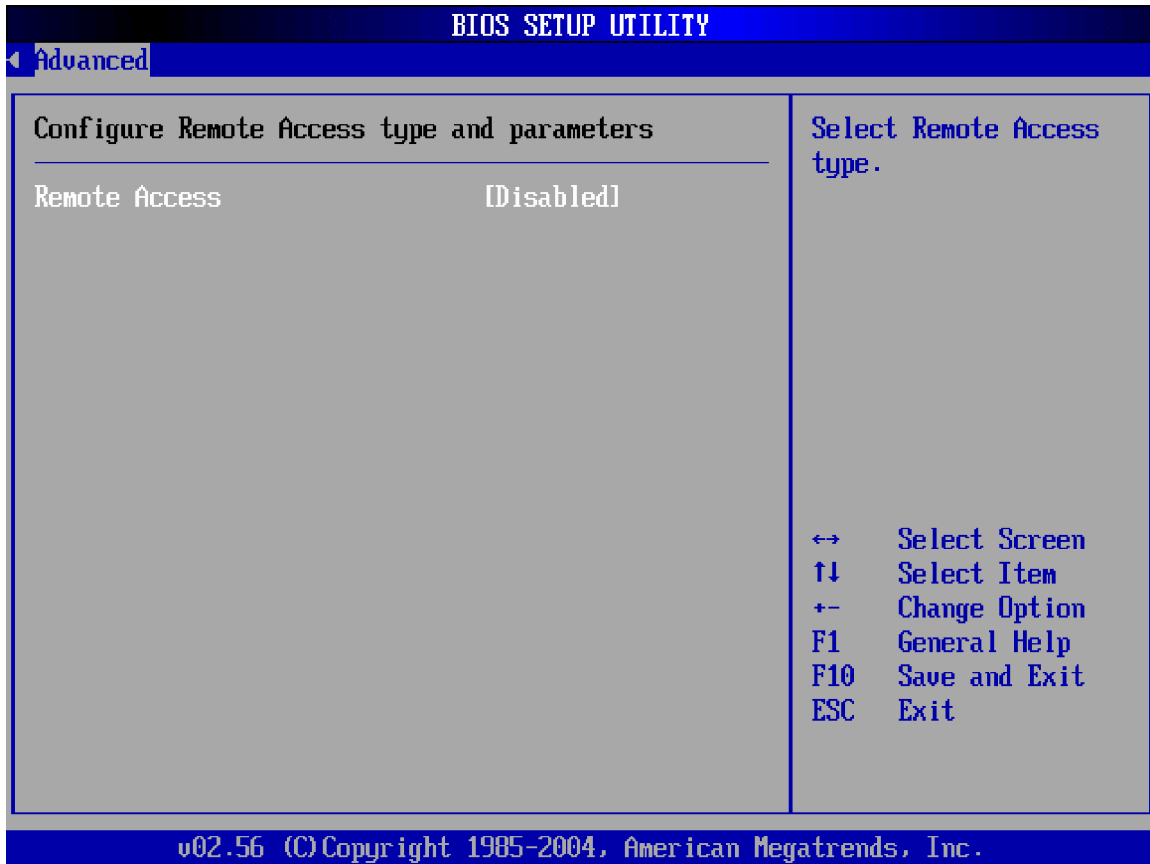

#### BIOS Menu 12: Remote Access Configuration [Advanced]

##### ↑ Remote Access [Disabled]

↑ **Disabled** (DEFAULT) If selected, no configuration options will appear.

↑ **Enabled** If selected the remote access configuration options shown below will appear:

- „ Serial Port Number
- „ Serial Port Mode
- „ Flow Control
- „ Redirection after BIOS Post
- „ Terminal Type

„ VT-UTF8 Combo Key Support

These configuration options are discussed below.

**Serial Port Number [COM1]**

**COM1** (DEFAULT) If selected the system can be remotely accessed through COM1

**COM2** If selected the system can be remotely accessed through COM2

**NOTE:** Make sure the selected COM port is enabled through the Super I/O configuration menu.

**Serial Port Mode [115200 8,n,1]**

The **Serial Port Mode** designates baud rate through which the console redirection is made.

The following configuration options are available

- „ 115200 8,n,1 (DEFAULT)
- „ 57600 8,n,1
- „ 38400 8,n,1
- „ 19200 8,n,1
- „ 09600 8,n,1



**NOTE:**

Identical baud rate setting must be set to the host (a management computer running a terminal software) and slave (the ICPMB-8550 system being remotely accessed)

---

**Flow Control [None]**

This selection selects the flow control for the console redirection.

 **None** (DEFAULT)

 **Hardware**

 **Software**

#### **Redirection After BIOS POST [Always]**

 **Disabled** Turns off the redirection after POST

 **Boot Loader** Redirection is active during POST and during Boot Loader

 **Always** (DEFAULT) Redirection is always active (Some OSes may not work if set to Always)

#### **Terminal Type [ANSI]**

 **ANSI** (DEFAULT) The target terminal type is ANSI

 **VT100** The target terminal type is VT100

 **VT-UTF8** The target terminal type is VT-UTF8

#### **VT-UTF8 Combo Key Support [Disabled]**

 **Disabled** (DEFAULT) Disables the VT-UTF8 terminal keys

 **Enabled** Enables the VT-UTF8 combination key. Support for ANSI/VT100 terminals

### 5.3.9 USB Configuration

The **USB Configuration** menu (**BIOS Menu 13**) gives you information on the USB configuration and allows you to configure some USB features.

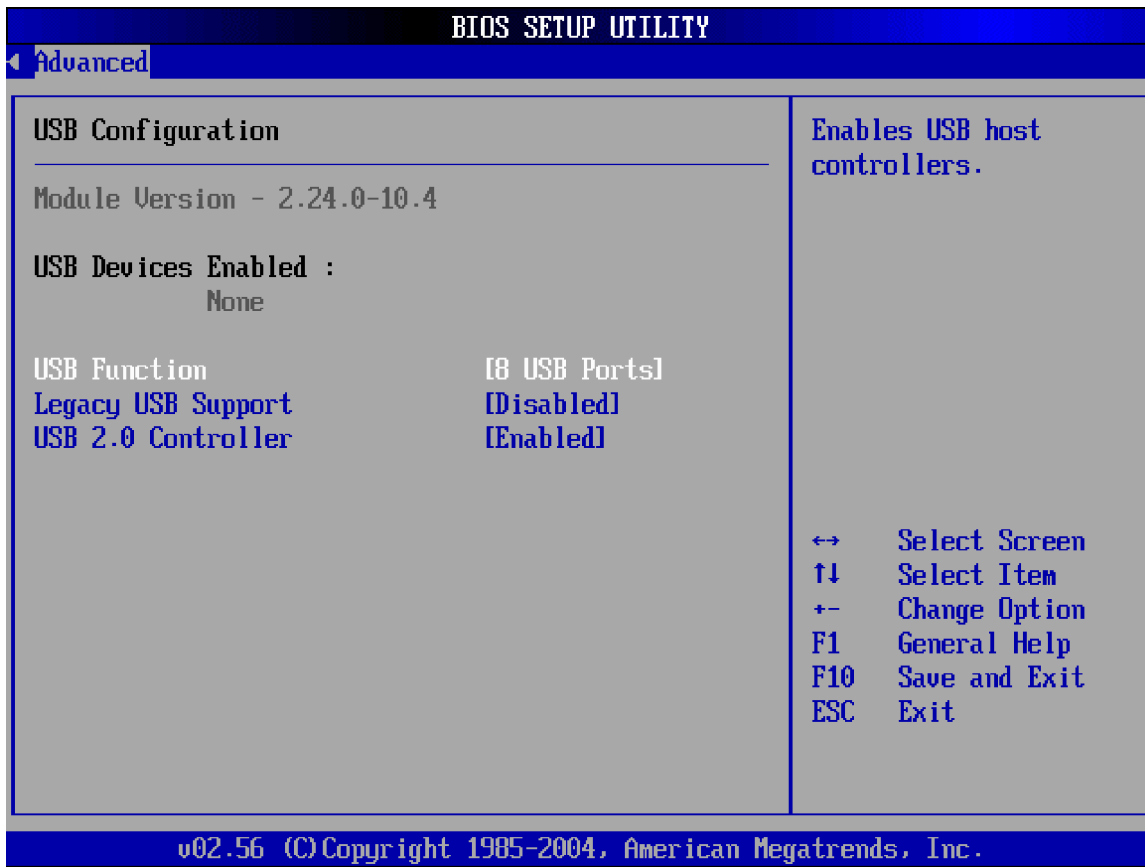

**BIOS Menu 13: USB Configuration [Advanced]**

**↑ USB Configuration**

The USB Configuration field shows the system USB configuration. The items listed are:



„ Module Version: x.xxxxx.xxxxx

**↑ USB Devices Enabled:**

Lists the USB devices that are enabled on the system

**↑ USB Function [8 USB Ports]**



- ↑ Disabled No USB ports activated
- ↑ 2 USB Ports 2 USB ports activated

-  **4 USB Ports** 4 USB ports activated
-  **6 USB Ports** 6 USB ports activated
-  **8 USB Ports** (DEFAULT) 8 USB ports activated

#### Legacy USB Support [Disabled]

-  **Disabled** (DEFAULT) Legacy USB support disabled
-  **Enabled** Legacy USB support enabled

#### USB 2.0 Controller [Disabled]

-  **Enabled** USB 2.0 controller enabled
-  **Disabled** (DEFAULT) USB 2.0 controller disabled

## 5.4 PCI/PnP

The **PCI/PnP** menu (**BIOS Menu 13**) allows you to configure advanced PCI and PnP settings.



### **WARNING!**

Setting wrong values for the BIOS selections in the PCIPnP BIOS menu may cause your system to malfunction.

---

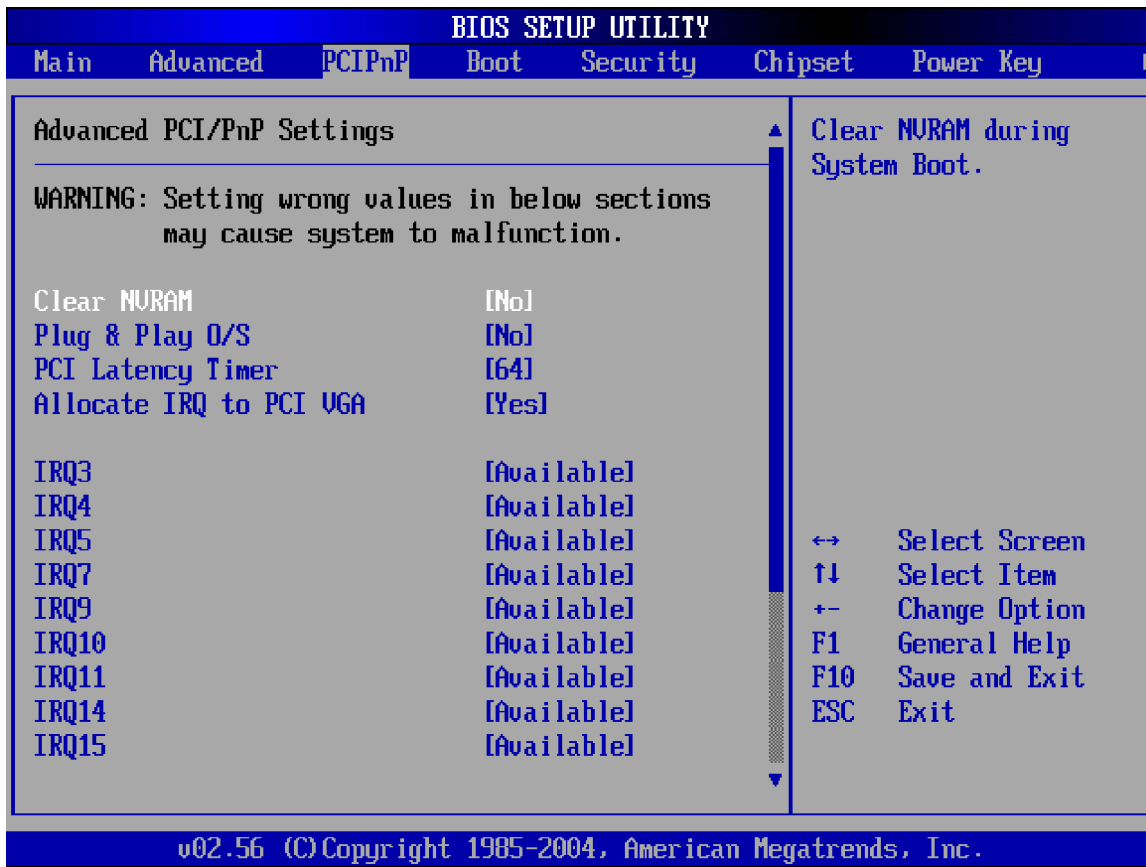

BIOS Menu 14: PCI/PnP Configuration [Part 1]

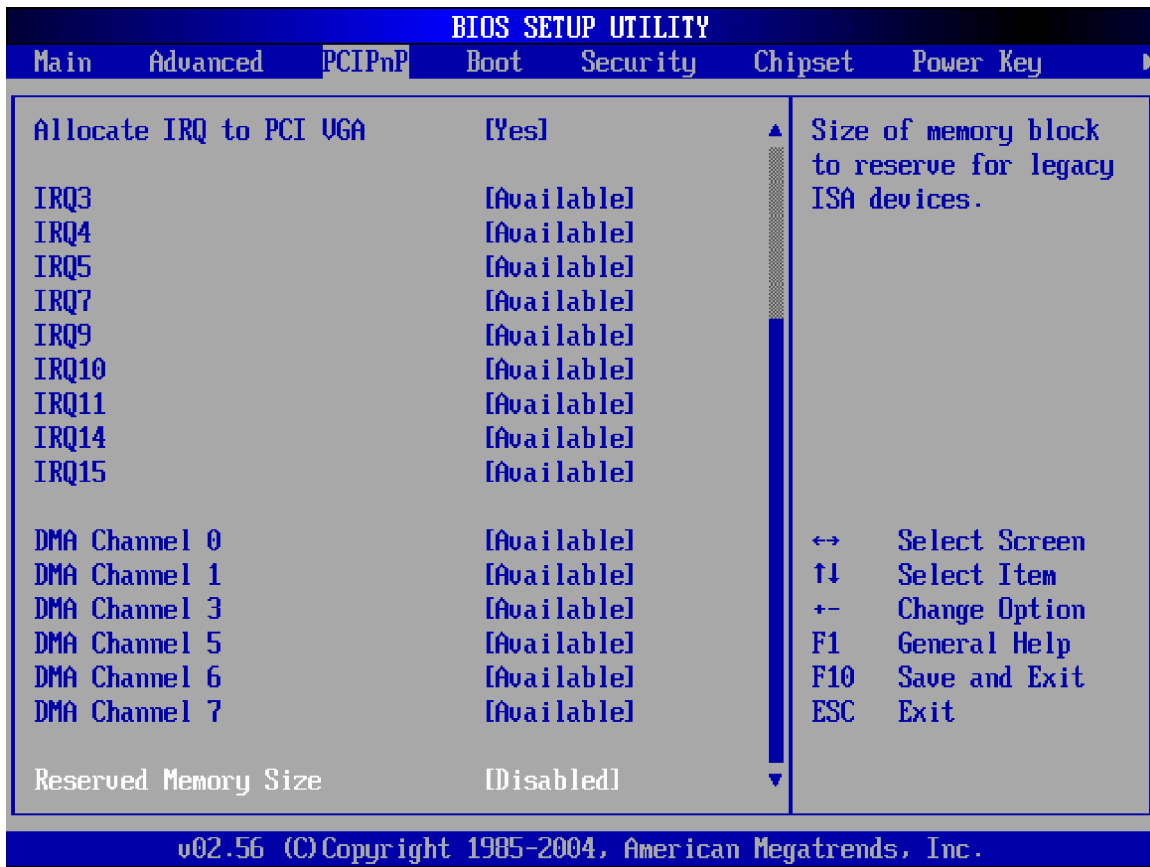

### BIOS Menu 15: PCI/PnP Configuration [Part 2]

#### ↑ Clear NVRAM [No]

↑ **No** (DEFAULT) System does not clear NVRAM during system boot

↑ **Yes** System clears NVRAM during system boot

#### ↑ Plug & Play O/S [No]

↑ **No** (DEFAULT) Lets BIOS configure all system devices

↑ **Yes** Lets OS configure Plug and Play (PnP) devices not required for boot if your system has a Plug and Play OS

**PCI Latency Timer [64]**

The values stipulated in the PCI Latency Timer are in units of PCI clock cycles for the PCI device latency timer register. Configuration options are:

- ” 32
- ” 64 (Default)
- ” 96
- ” 128
- ” 160
- ” 192
- ” 224
- ” 248

**Allocate IRQ to PCI VGA [Yes]**

**Yes** (DEFAULT) Assigns an IRQ to a PCI VGA card if card requests IRQ

**No** Does not assign IRQ to a PCI VGA card even if the card requests an IRQ

**IRQ# [Available]**

**Available** (DEFAULT) The specified IRQ is available to be used by PCI/PnP devices

**Reserved** The specified IRQ is reserved for use by Legacy ISA devices



Available IRQ addresses are:

- ” IRQ3
- ” IRQ4
- ” IRQ5
- ” IRQ7
- ” IRQ9
- ” IRQ10



- „ IRQ 11
- „ IRQ 14
- „ IRQ 15





#### DMA Channel# [Available]

-  **Available** (DEFAULT) The specified DMA is available to be used by PCI/PnP devices
-  **Reserved** The specified DMA is reserved for use by Legacy ISA devices

Available DMA Channels are:

- „ DM Channel 0
- „ DM Channel 1
- „ DM Channel 3
- „ DM Channel 5
- „ DM Channel 6
- „ DM Channel 7

#### Reserved Memory Size [Disabled]

-  **Disabled** (DEFAULT) No memory block reserved for legacy ISA devices
-  **16K** 16KB reserved for legacy ISA devices
-  **32K** 32KB reserved for legacy ISA devices
-  **64K** 54KB reserved for legacy ISA devices

## 5.5 Boot

The **Boot** menu (**BIOS Menu 16**) allows you to configure system boot options.

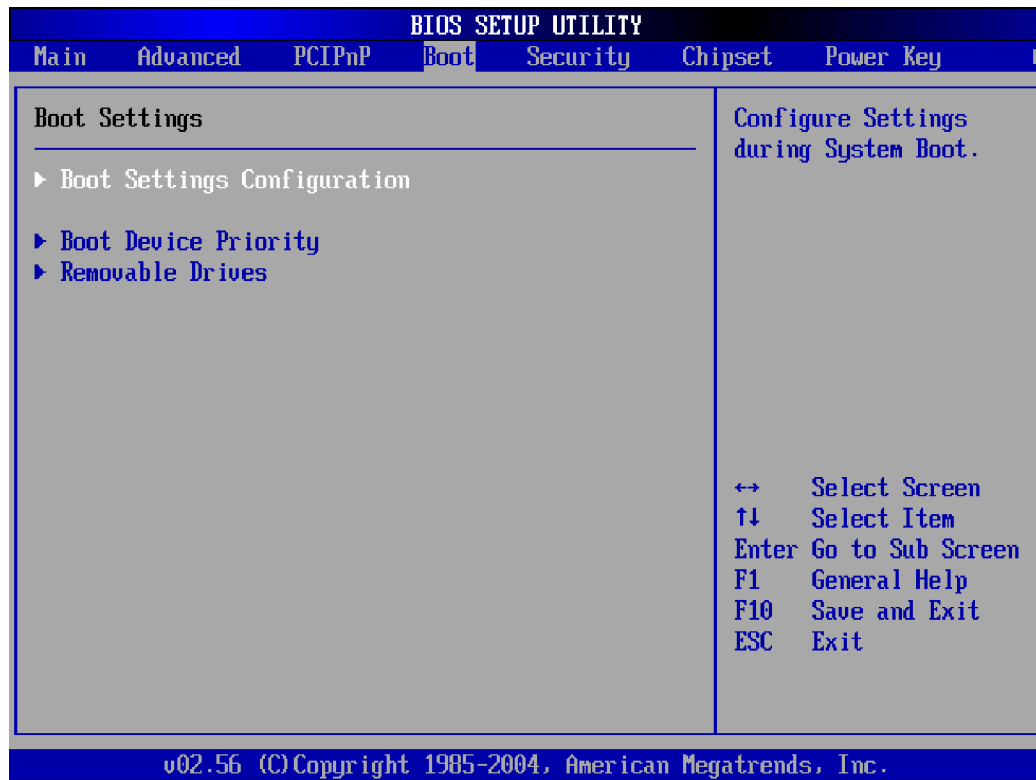

**BIOS Menu 16: Boot**

**5.5.1 Boot Settings Configuration**

The **Boot Settings Configuration** menu (**BIOS Menu 16**) allows you to configure advanced system boot options.

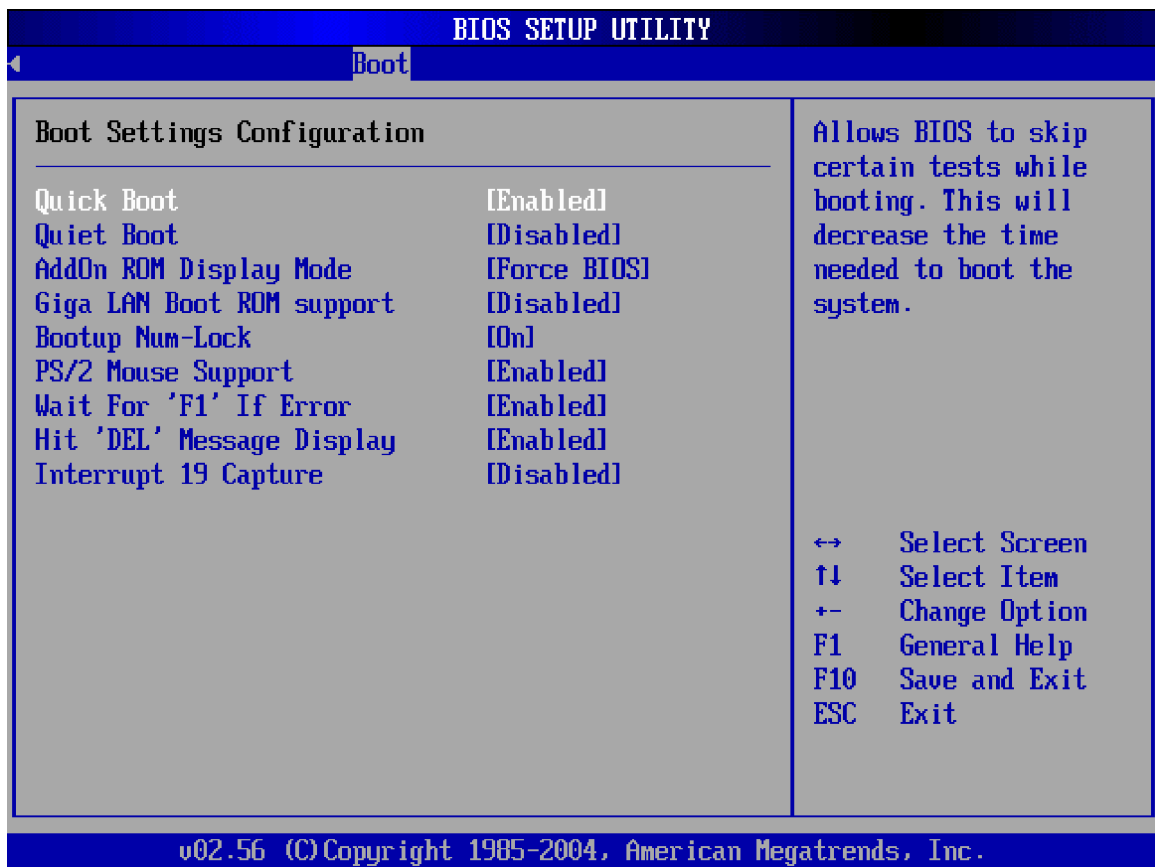

### BIOS Menu 17: Boot Settings Configuration [Boot]

#### ↑ Quick Boot [Enabled]

↑ Disabled System will not skip any POST procedures

↑ Enabled (DEFAULT) Allows system to skip some POST procedures to increase the system boot time

#### ↑ Quiet Boot [Disabled]

↑ Disabled (DEFAULT) Displays normal POST messages

↑ Enabled Displays OEM Logo instead of POST messages

#### ↑ AddOn ROM Display Mode [Force BIOS]

↑ Force BIOS (DEFAULT)

 **Keep Current**

 **Giga LAN Boot ROM Support [Disabled]**

 **Enabled** Enables LAN boot ROM

 **Disabled** (DEFAULT) Disables LAN Boot ROM

 **Bootup Num-Lock [On]**

 **Off** Selects Power-off state for NumLock

 **On** (DEFAULT) Selects Power-on state for NumLock

 **PS/2 Mouse Support [Enabled]**

 **Disabled** Disables PS/2 mouse support

 **Enabled** (DEFAULT) Enables PS/2 mouse support

 **Wait For 'F1' If Error [Enabled]**

 **Disabled** If an error occurs, the system will not wait for the F1 key to be pressed.

 **Enabled** (DEFAULT) If an error occurs, system will wait for the F1 key to be pressed.

 **Hit 'DEL' Message Display [Enabled]**

 **Disabled** No message displayed during POST

 **Enabled** (DEFAULT) Displays "Press DEL to run Setup" message in POST

 **Interrupt 19 Capture [Disabled]**

 **Disabled** (DEFAULT) Does not allow optional ROM to trap interrupt 19

 **Enabled** Allows optional ROM to trap interrupt 19

## 5.5.2 Boot Device Priority

The **Boot Device Priority** menu (**BIOS Menu 18**) specifies the boot sequence from the available devices. A device enclosed in the parenthesis has been disabled in the corresponding type menu.

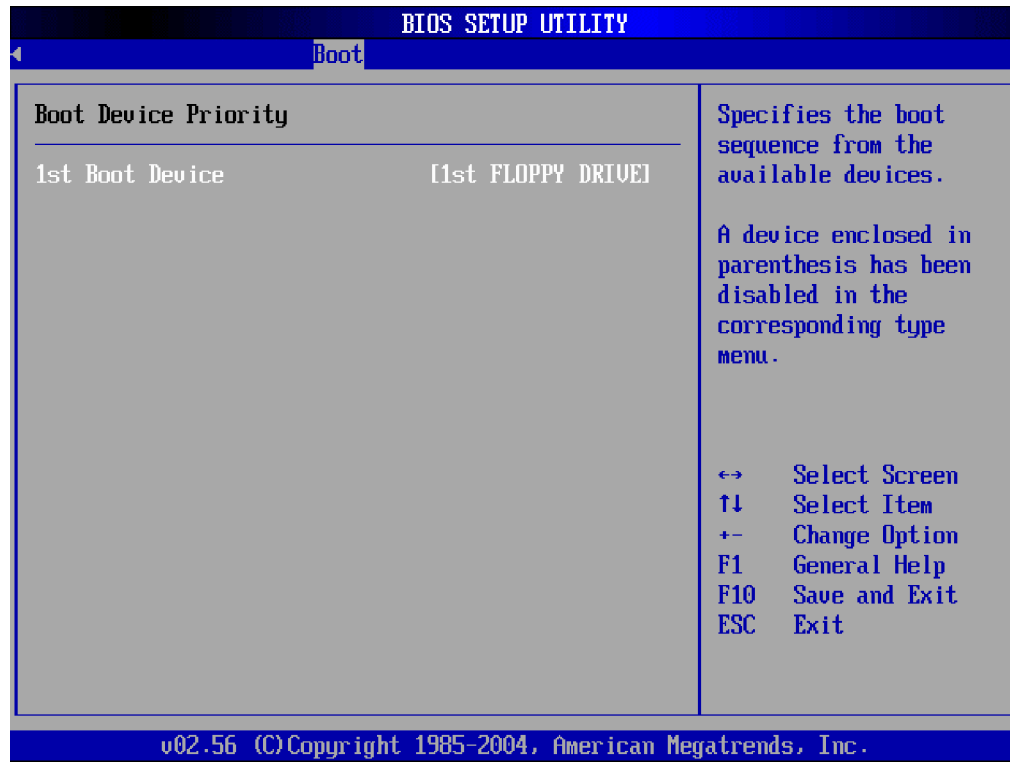

**BIOS Menu 18: Boot Device Priority Settings [Boot]**

## 5.5.3 Removable Drives

The **Removable Drives** menu (**BIOS Menu 19**) specifies the boot sequence from the available removable drives.

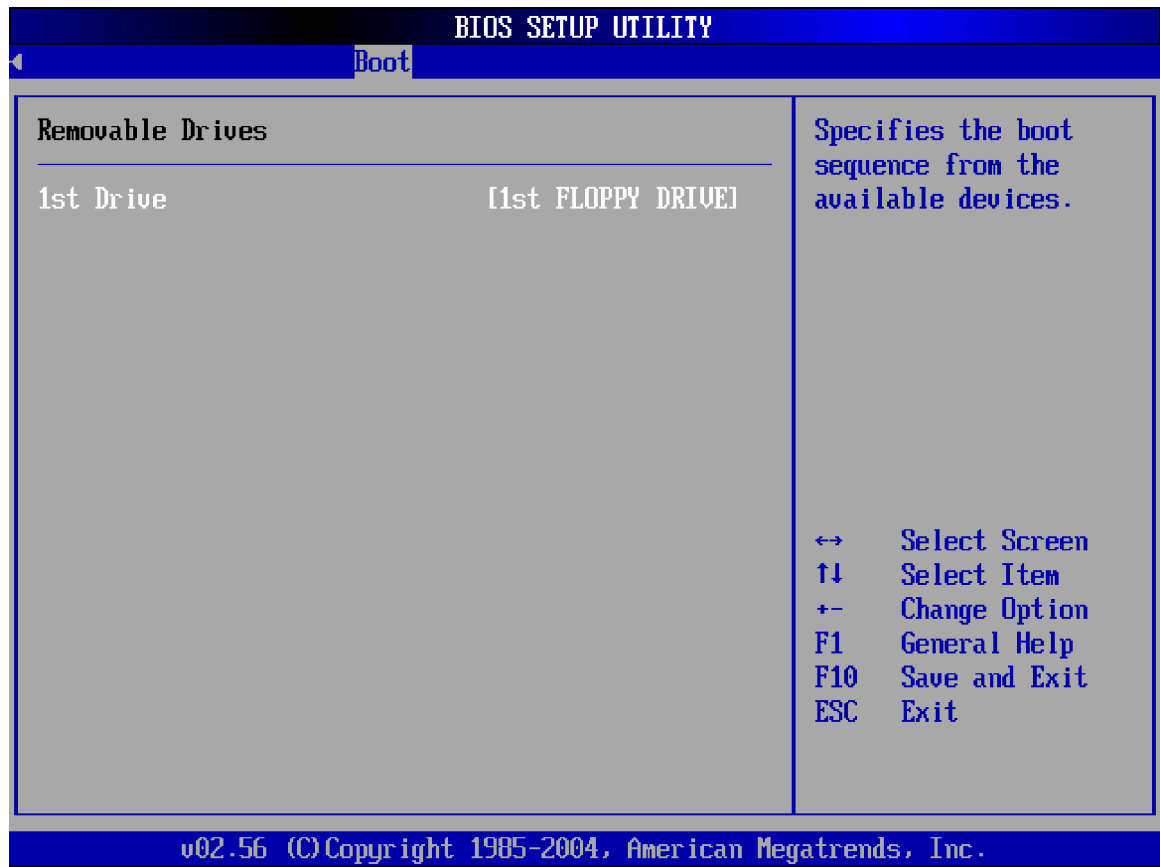

**BIOS Menu 19: Removable Drives [Boot]**

## 5.6 Security

The **Security** menu (**BIOS Menu 20**) allows you to configure the system security settings including passwords.

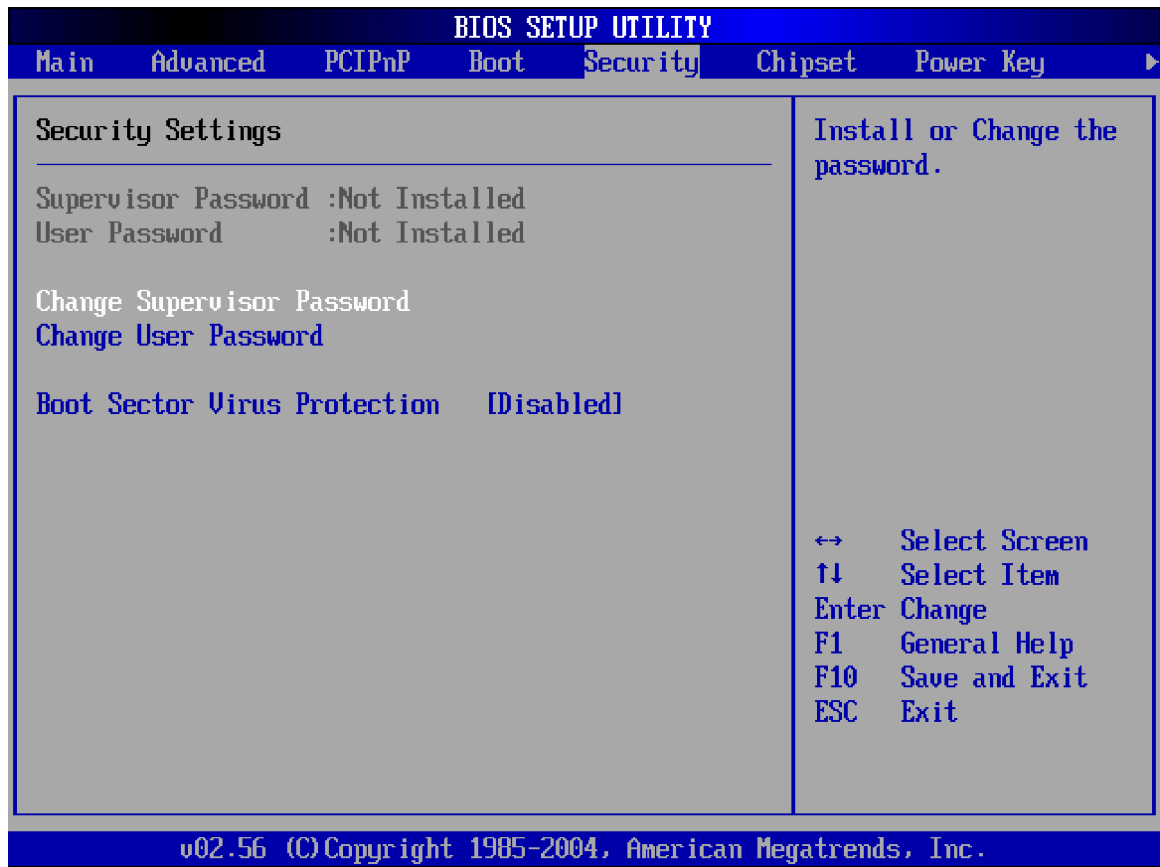

## BIOS Menu 20: Security

### ↑ Change Supervisor Password

The default setting for the **Change Supervisor Password** is **Not Installed**. If you wish to install a supervisor password, select this field and enter the password. After the password has been added, **Install** will appear next to **Change Supervisor Password**.

### ↑ Change User Password

The default setting for the **Change User Password** is **Not Installed**. If you wish to install a user password, select this field and enter the password. After the password has been added, **Install** will appear next to **Change User Password**.

### ↑ Boot Sector Virus Protection [Disabled]

↑ **Disabled** (DEFAULT) Disables the boot sector virus protection



Enabled

Enables the boot sector virus protection

## 5.7 Chipset

The **Chipset** menu (**BIOS Menu 21**) has two sub-menus, **NorthBridge Configuration** and **SouthBridge Configuration**. The **NorthBridge Configuration** menu allows you to configure the northbridge chipset and the **SouthBridge Configuration** menu allows you to configure the southbridge chipset.



### **WARNING!**

Setting the wrong values for the Chipset BIOS selections in the Chipset BIOS menu may cause the system to malfunction.

---





## BIOS Menu 21: Chipset

### 5.7.1 North Bridge Configuration

The NorthBridge Configuration menu (**BIOS Menu 21**) allows you to configure the northbridge chipset.

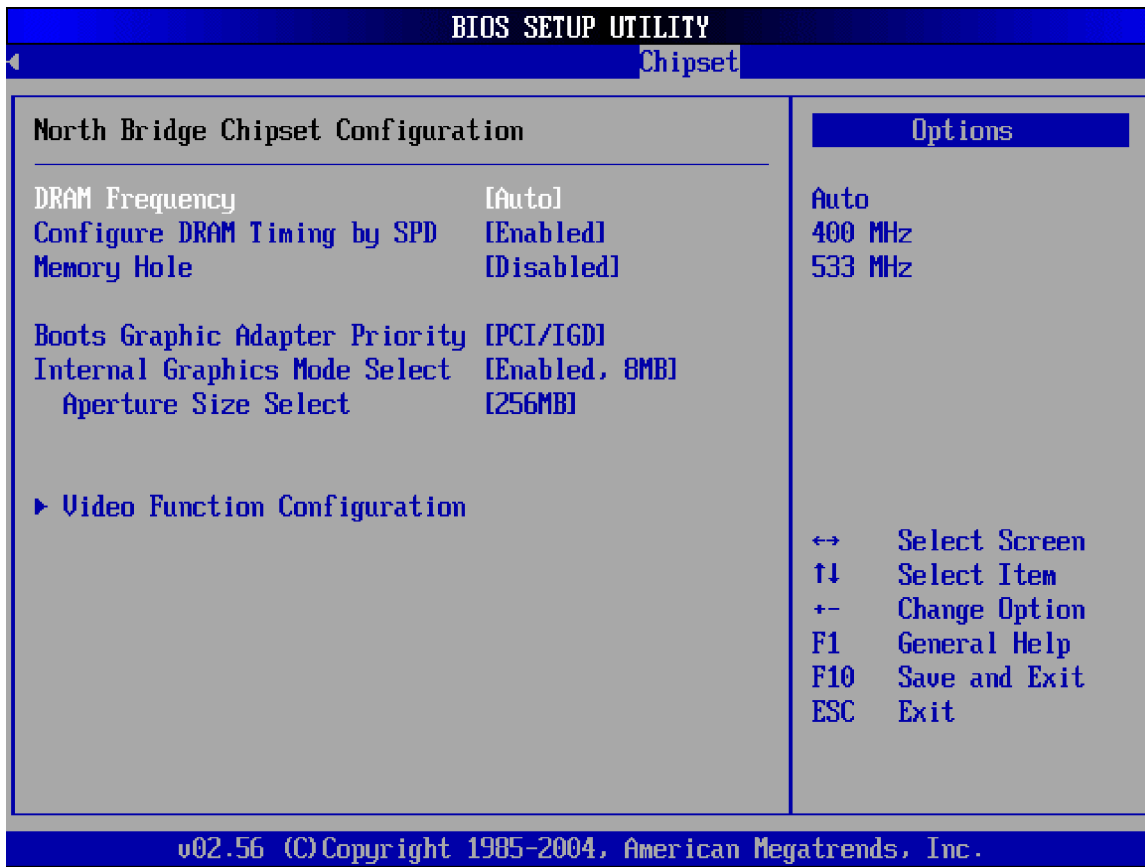

BIOS Menu 22:NorthBridge Chipset Configuration [Chipset]

- ↑ DRAM Frequency [Auto]

  - ↑ Auto (DEFAULT) Automatically selects the DRAM frequency
  - ↑ 400MHz Sets the DRAM frequency to 400MHz
  - ↑ 533MHz Sets the DRAM frequency to 533MHz
  
- ↑ Configure DRAM Timing by SPD [Enabled]

  - ↑ Disabled DRAM timing parameters can be manually set using the DRAM sub-items
  - ↑ Enabled (DEFAULT) DRAM timing parameter are set according to the DRAM Serial Presence Detect (SPD)

### Memory Hole [Disabled]

Disabled (DEFAULT) The memory hole is disabled

15MB – 16MB

### Boots Graphic Adapter Priority [PCI/IGD]

IGD Selects IGD as the graphics controller to use as the primary boot device

PCI/IGD (DEFAULT) Selects the PCI/IGD as the graphics controller to use as the primary boot device.

### Internal Graphics Mode Select [Enable, 8MB]

Disable

Enable, 1MB 1MB of memory used by internal graphics device

Enable, 8MB (DEFAULT) 8MB of memory used by internal graphics device

### Aperture Size Select [256MB]

128MB Graphics aperture size set as 128MB

256MB (DEFAULT) Graphics aperture size set as 256MB

## 5.7.1.1 Video Function Configuration

The Video Function Configuration menu (**BIOS Menu 23**) allows you to configure the Video Function Configuration.

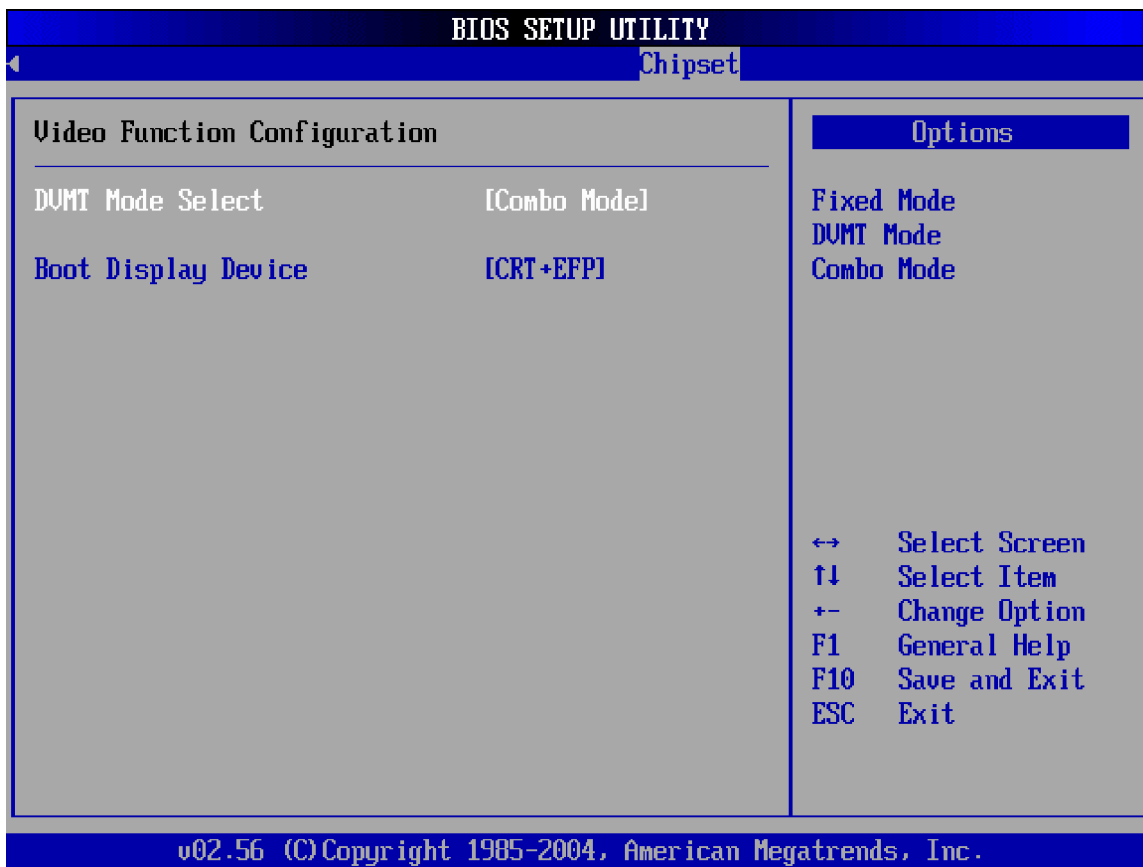

### BIOS Menu 23:Video Function Configuration [Chipset/Northbridge]

#### ↑ DVMT Mode Select [Comob Mode]



##### Fixed Mode

The graphics driver will reserve a fixed portion of the system memory as graphics memory



##### DVMT Mode

The graphics chip will dynamically allocate system memory as graphics memory, according to system and graphics requirements



##### Combo Mode (DEFAULT)

The graphics driver will allocate a fixed amount of memory as dedicated graphics memory, as well as allow more system memory to be dynamically allocated between the graphics processor and the operating system.

⌈ Boot Display Device [CRT + EFP]

⌈ CRT

⌈ EFP

⌈ CRT + EFP (DEFAULT)

## 5.7.2 South Bridge Chipset Configuration

The **SouthBridge Configuration** menu (**BIOS Menu 24**) allows you to configure the southbridge chipset.

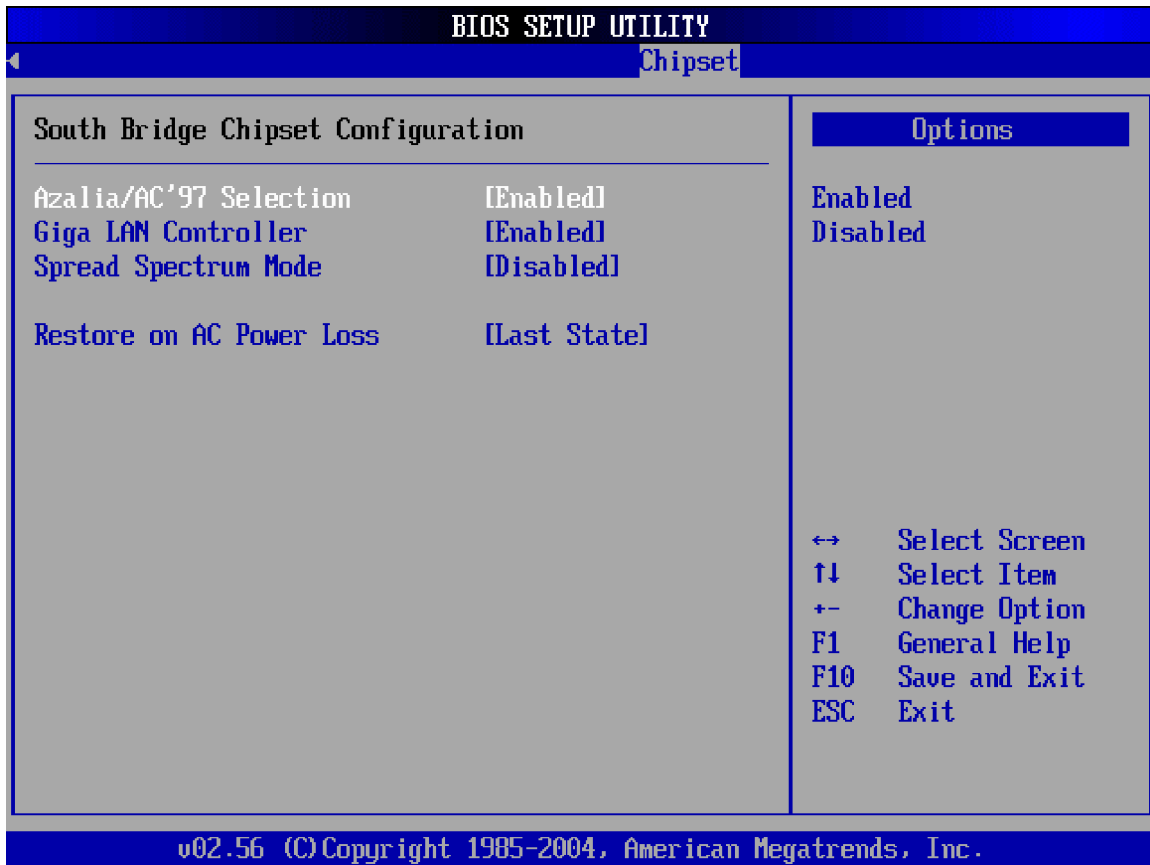

### BIOS Menu 24:SouthBridge Chipset Configuration [Chipset]

⌈ Azalia/AC'97 Selection [Enabled]

⌈ Enabled (DEFAULT) Onboard Azalia/ AC'97 automatically detected and

		enabled
↑	<b>Disabled</b>	Onboard AC'97 manually disabled
]		
↑	<b>Giga LAN Controller [Enabled]</b>	
↑	<b>Enabled</b> (DEFAULT)	Enables the gigabit LAN controller
↑	<b>Disabled</b>	Disables the gigabit LAN controller
↑	<b>Spread Spectrum Configuration [Disabled]</b>	
↑	<b>Enabled</b>	Enables the clock generator spread spectrum
↑	<b>Disabled</b> (DEFAULT)	Disables the clock generator spread spectrum
↑	<b>Restore on AC Power Loss [Last State]</b>	
↑	<b>Power Off</b>	The system goes off after an AC power loss
↑	<b>Power On</b>	The system goes on after an AC power loss
↑	<b>Last State</b> (DEFAULT)	If the system was on before the AC power loss, after the power loss the system will turn itself back on. If the system was off before the AC power loss, it will remain off once the power is restored

## 5.8 Power Key

The **Power** menu (**BIOS Menu 25**) allows you to configure advanced power management options.

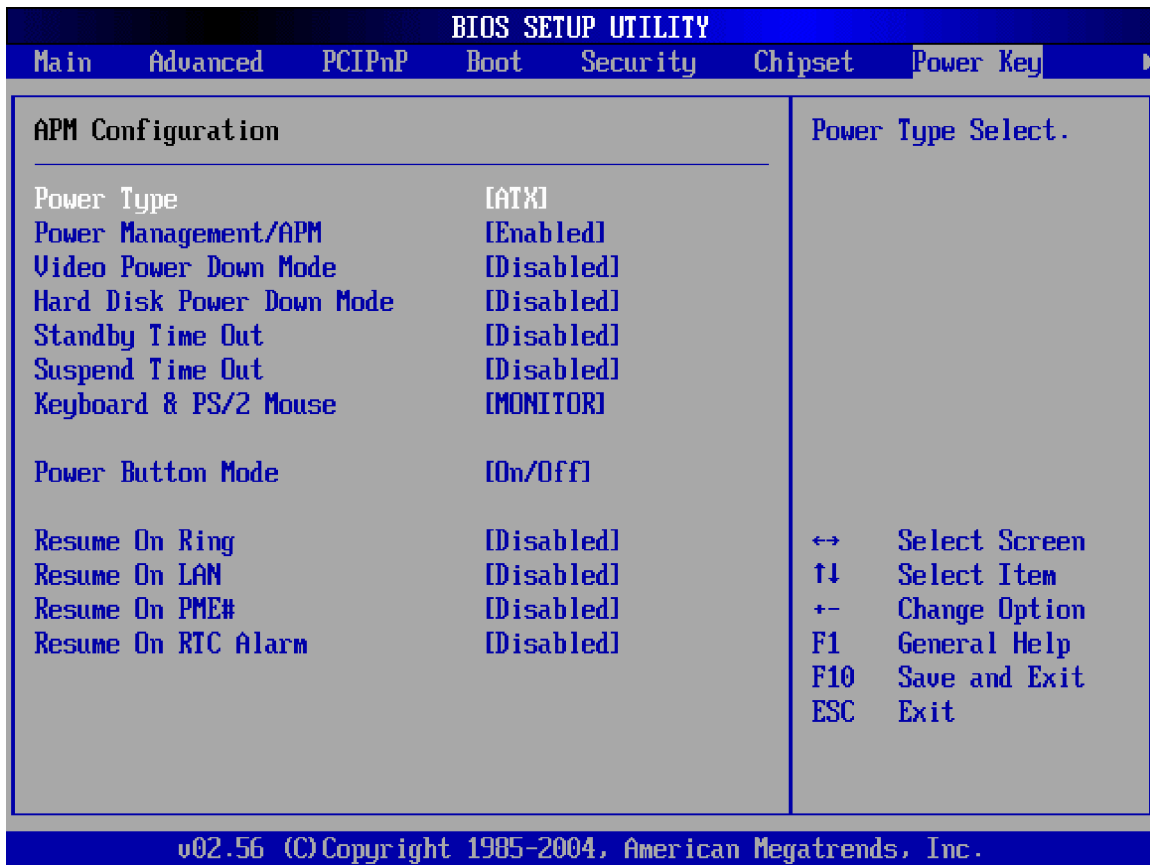

### BIOS Menu 25:Power

#### ⌄ Power Type [ATX]

⌄ AT BIOS sets power type as AT

⌄ ATX (DEFAULT) BIOS sets power type as ATX

#### ⌄ Power Management/APM [Enabled]

⌄ Disabled Disables the Advanced Power Management (APM) feature

⌄ Enabled (DEFAULT) Enables the APM feature

#### ⌄ Video Power Down Mode [Disabled]

- ⌆ **Disabled** (DEFAULT) The Video cannot be turned off in the Suspend or Standby mode
- ⌆ **Standby** The video can be turned off in the Standby mode
- ⌆ **Suspend** The video can be turned off in the Suspend mode

## ⌆ **Hard Disk Power Down Mode [Disabled]**

- ⌆ **Disabled** (DEFAULT) The HDD cannot be turned off in the Suspend or Standby mode
- ⌆ **Standby** The HDD can be turned off in the Standby mode
- ⌆ **Suspend** The HDD can be turned off in the Suspend mode

## ⌆ **Standby Time Out [Disabled]**

The **Standby Time Out** option allows you to specify what length of time without activity on the system will place the system in Standby mode. If you select **Disabled** the system will never go into standby mode. The options are listed below:

- „ Disabled (DEFAULT)
- „ 1 Min
- „ 2 Min
- „ 4 Min
- „ 8 Min
- „ 10 Min
- „ 20 Min
- „ 30 Min
- „ 40 Min
- „ 50 Min
- „ 60 Min



## ⌆ **Suspend Time Out [Disabled]**





The **Suspend Time Out** option allows you to specify what length of time without activity on certain components will place those components in a suspended state. The options are listed below:

- „ Disabled (DEFAULT)
- „ 1 Min
- „ 2 Min
- „ 4 Min
- „ 8 Min
- „ 10 Min
- „ 20 Min
- „ 30 Min
- „ 40 Min
- „ 50 Min
- „ 60 Min]



#### **Keyboard & PS/2 Mouse [Monitor]**

-  **Ignore** Activity on the KBC ports 60/6 is not monitored
-  **Monitor** (DEFAULT) Activity on the KBC Ports 60/6 is monitored

#### **Power Button Mode [On/Off]**

-  **On/Off** (DEFAULT) When the power button is pressed the system is either turned on or off
-  **Suspend** When the power button is pressed the system goes into suspend mode

#### **Resume On Ring [Disabled]**

-  **Disabled** (DEFAULT) R1 does not generate a wake event
-  **Enabled** R1 generates a wake event

#### **Resume On LAN [Disabled]**

-  **Disabled** (DEFAULT) LAN GPI cannot generate a wake event

 **Enabled** LAN GPI can generate a wake event

### **Resume On PME# [Disabled]**

 **Disabled** (DEFAULT) PCI PME# cannot generate a wake event

 **Enabled** PCI PME# can generate a wake event

### **Resume On RTC Alarm [Disabled]**

 **Disabled** (DEFAULT) The real time clock (RTC) cannot generate a wake event

 **Enabled** If selected, the following will appear with values that can be selected:

 **RTC Alarm Date (Days)**

 **System Time**

After setting the alarm, the computer will turn itself on from a suspend state when the alarm goes off.

## 5.9 Exit

The **Exit** menu (**BIOS Menu 26**) allows you to load default BIOS values, optimal failsafe values and to save configuration changes.

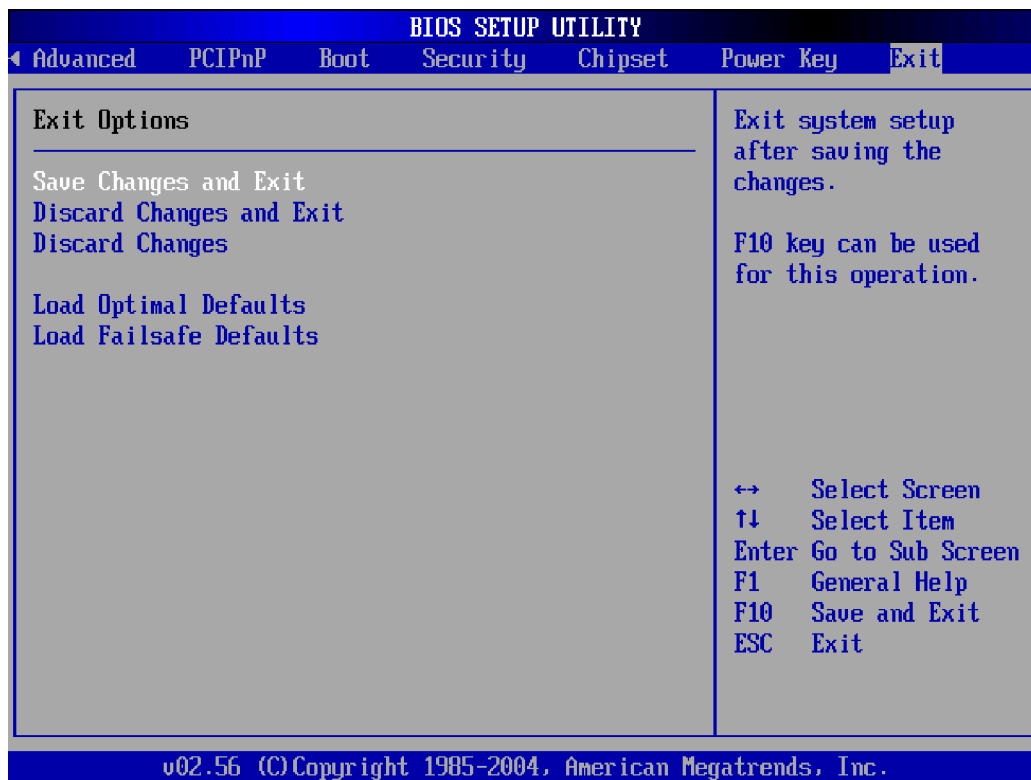

### BIOS Menu 26:Exit

#### ↑ Save Changes and Exit

If you have finished making the configuration changes and wish to save them and exit the BIOS menus, select this option.

#### ↑ Discard Changes and Exit

If you have finished making configuration changes but do not want to save them and you want to exit the BIOS menus, select this option.

#### ↑ Discard Changes

If you have finished making configuration changes but do not want to save them but still want to continue working with BIOS, select this option.

### **Load Optimal Defaults**

This option allows you to load optimal default values for each of the parameters on the Setup menus. **F9 key can be used for this operation.**

### **Load Failsafe Defaults**

This option allows you to load failsafe default values for each of the parameters on the Setup menus. **F8 key can be used for this operation.**

Chapter

**6**

# 6 Software Drivers

---

## 6.1 Available Software Drivers

---



### NOTE:

The content of the CD may vary throughout the life cycle of the product and is subject to change without prior notice. You may visit the GAI website ([www.globalamericaninc.com](http://www.globalamericaninc.com)) or contact technical support for the latest updates.

---

The 3301690 CPU card has four software drivers:

- „ Intel chipset driver
- „ Intel Graphics Media Accelerator driver
- „ Marvell gigabit Ethernet controller driver
- „ RealTek AC'97 Audio CODEC driver

All four drivers can be found on the CD that came with the CPU card. To install the drivers please follow the instructions in the sections below

## 6.2 Chipset Driver Installation

To install the chipset driver, please follow the steps below:

**Step 1:** Insert the CD into the system that contains the 3301690 CPU card. Open the CD folder and locate the icon for the **infinst\_autol.exe** installation file. Once located, use the mouse to move the cursor over the icon and double click the mouse button.

**Step 2:** Once you double click the **infinst\_autol.exe** icon, the screen shown in **Figure 6-1** should appear.

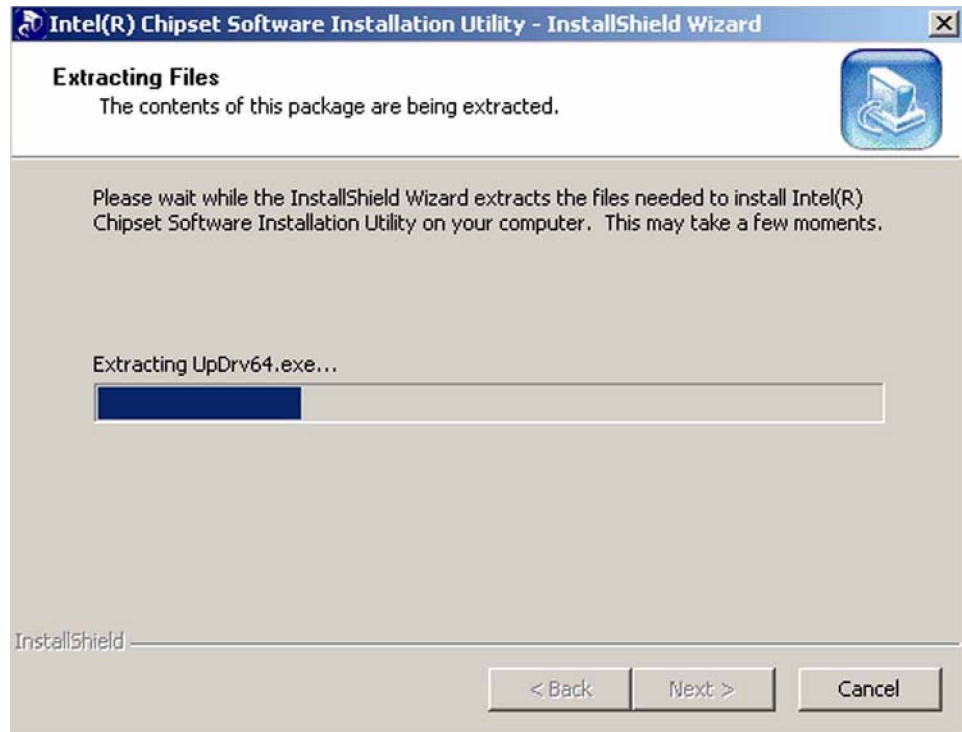

**Figure 6-1: Extracting Driver Installation Files**

**Step 3:** Once the files are extracted, a welcome screen shown in **Figure 6-2** appears.

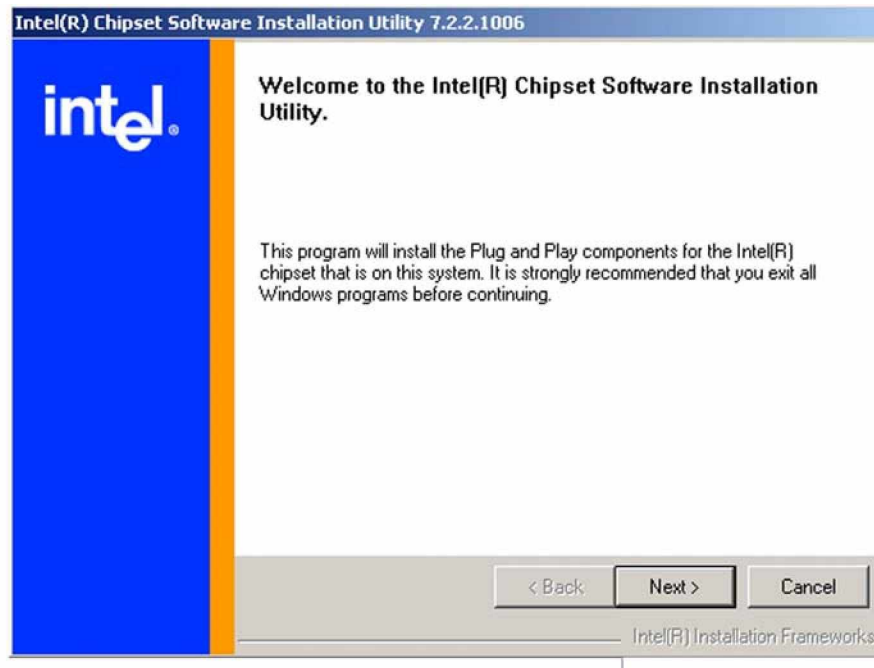

**Figure 6-2: Chipset Driver Installation Welcome Screen**

**Step 4:** After the welcome screen shown in **Figure 6-2** appears, to continue the installation process click the “**NEXT**” button. The license agreement shown in **Figure 6-3** will appear.

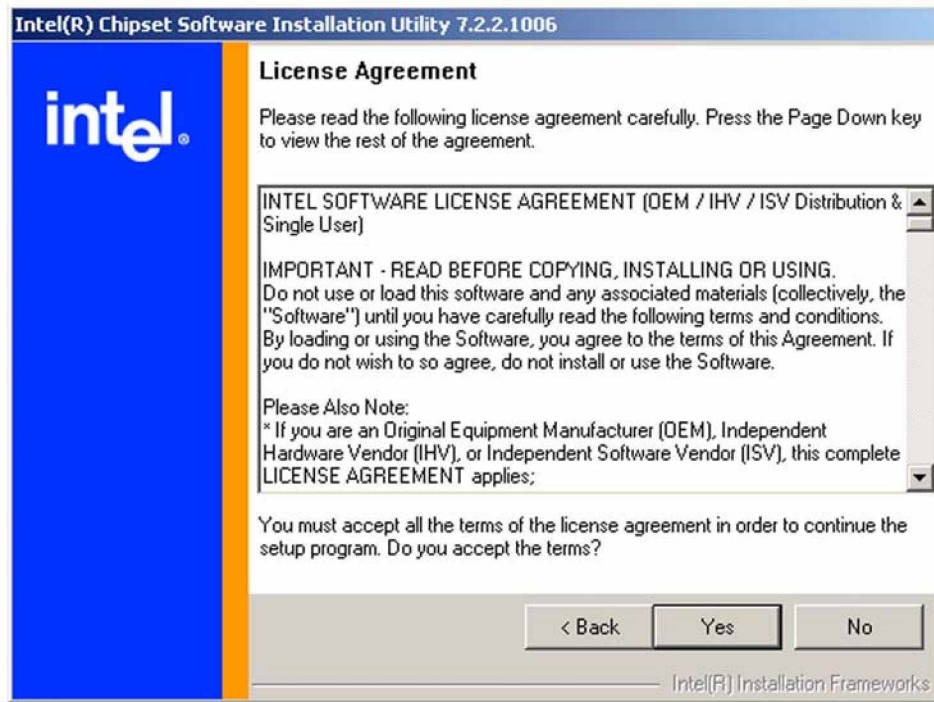

**Figure 6-3: Chipset Driver Installation License Agreement**

**Step 5:** Read through the license agreement in **Figure 6-3**. If you choose to accept the terms and conditions stipulated in the agreement then click the “**YES**” button. The Readme file information shown in **Figure 6-4** will appear.



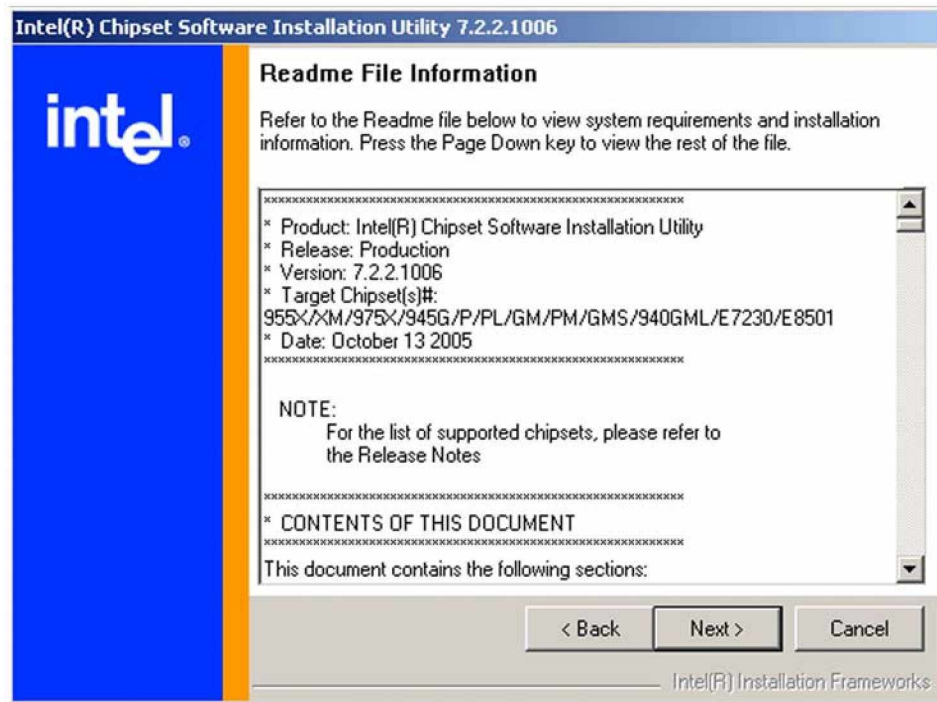

**Figure 6-4: Chipset Driver Readme File Information**

- Step 6:** After reading through the Readme file information shown in **Figure 6-4** click on the “**NEXT**” button and the chipset driver will be installed.
- Step 7:** After the driver installation process is complete, a confirmation screen shown in **Figure 6-5** will appear. Step 0:

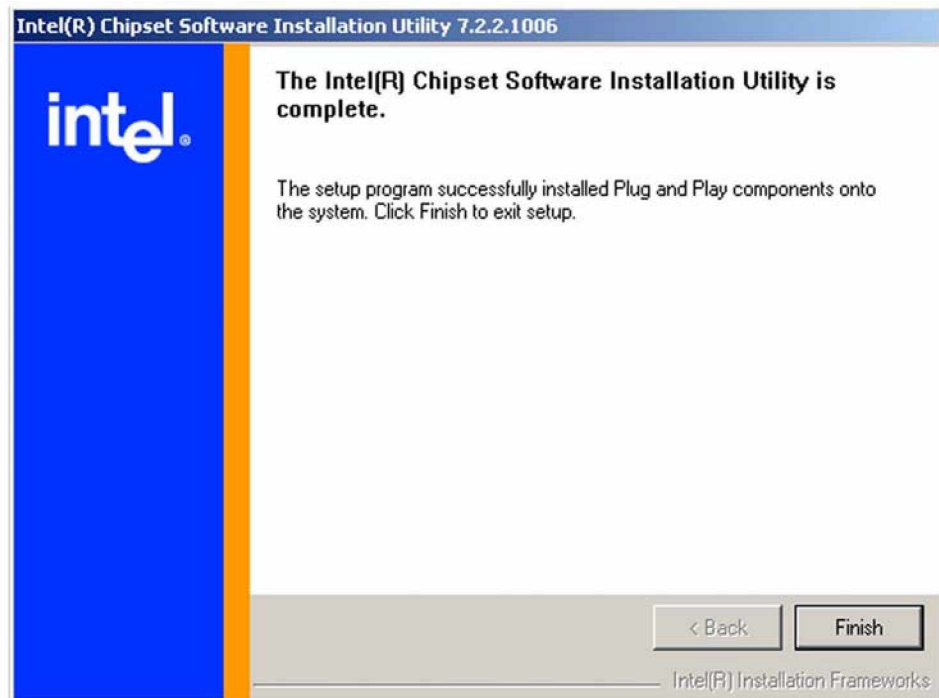

Figure 6-5: Chipset Driver Installation Complete

### 6.3 Intel Graphics Media Accelerator Driver

To install the GMA driver, please follow the steps below:

**Step 1:** Insert the CD into the system that contains the 3301690 CPU card. Open the CD folder and locate the icon for the **win2k\_xp141950.exe** installation file. Once located, use the mouse to move the cursor over the icon and double click the mouse button.

**Step 2:** Once you double click the **win2k\_xp141950.exe** icon, the Readme information file shown in **Figure 6-6** should appear.

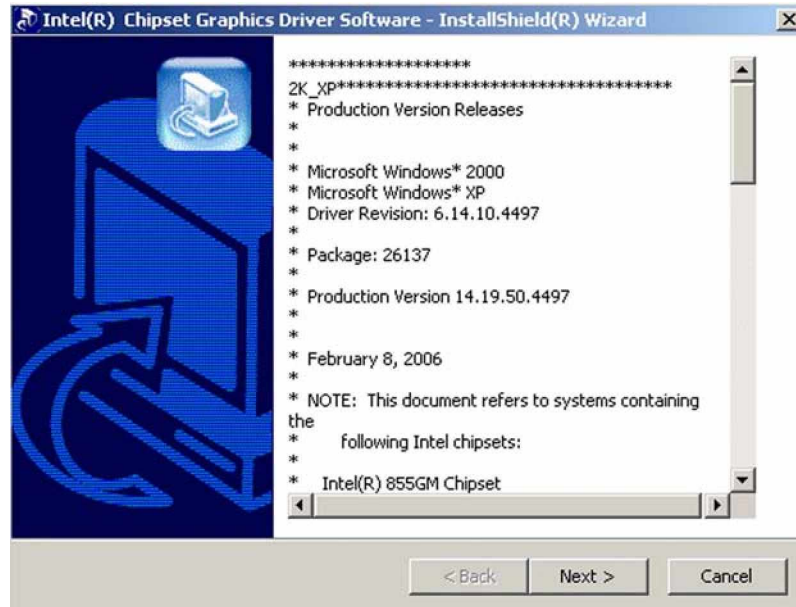

**Figure 6-6: GMA Driver Readme File**

**Step 3:** After you have finished reading the Readme file, click on the “**NEXT**” button and the GMA driver files are extracted. See **Figure 6-7**.

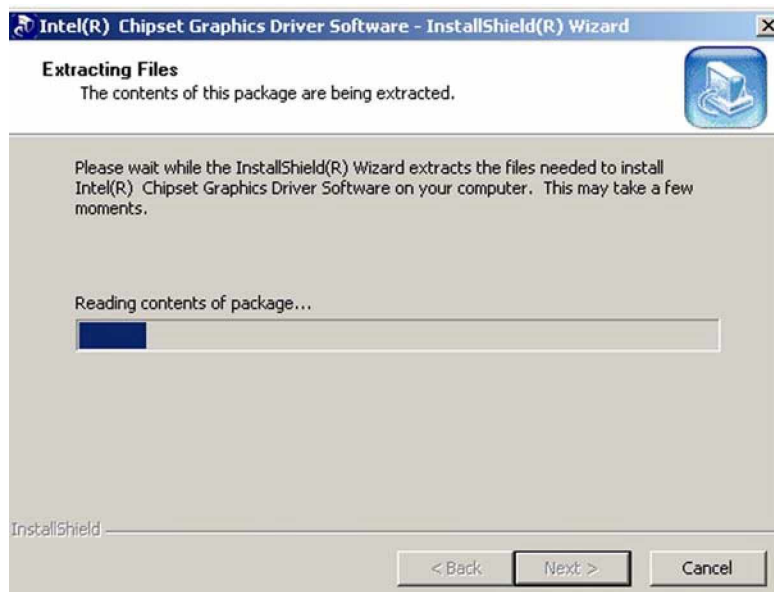

**Figure 6-7: GMA Driver File Extraction**

**Step 4:** After the files are extracted the welcome screen shown in **Figure 6-8** appears. To continue the installation process, click the “**NEXT**” button. The license agreement

shown in **Figure 6-9** will appear.

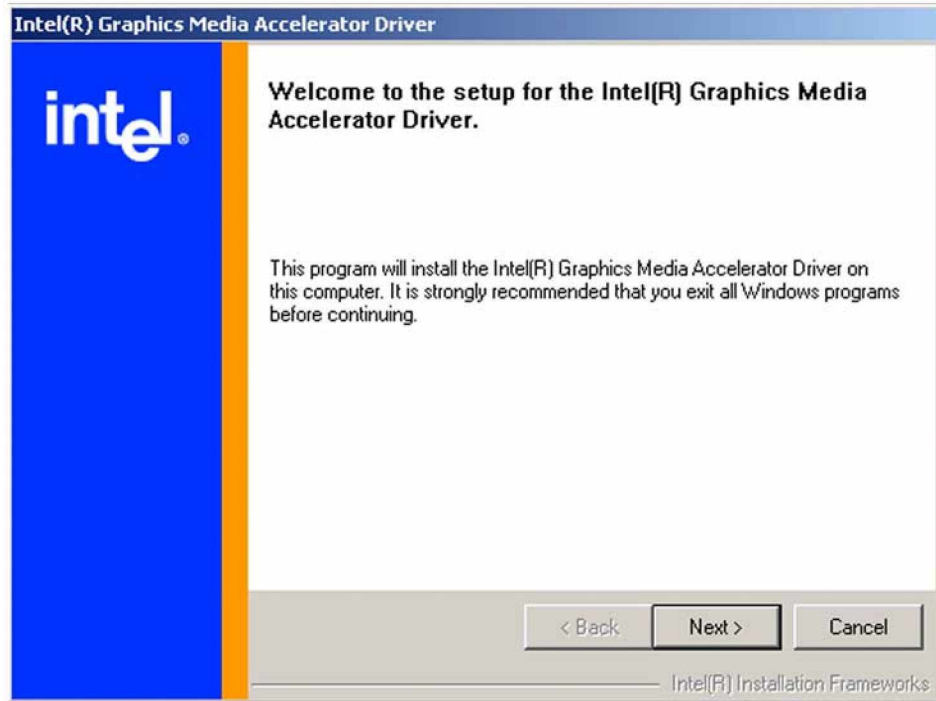

**Figure 6-8: GMA Driver Installation Welcome Screen**

**Step 5:** Read through the license agreement in **Figure 6-9**.



**Figure 6-9: GMA Driver License Agreement**

**Step 6:** If you choose to accept the terms and conditions stipulated in the license agreement shown **Figure 6-9**, click the “**Yes**” button. The installation notice shown in **Figure 6-10** will appear.



**Figure 6-10: GMA Driver Installing Notice**

**Step 7:** After the driver installation process is complete, a confirmation screen shown in **Figure 6-11** will appear.

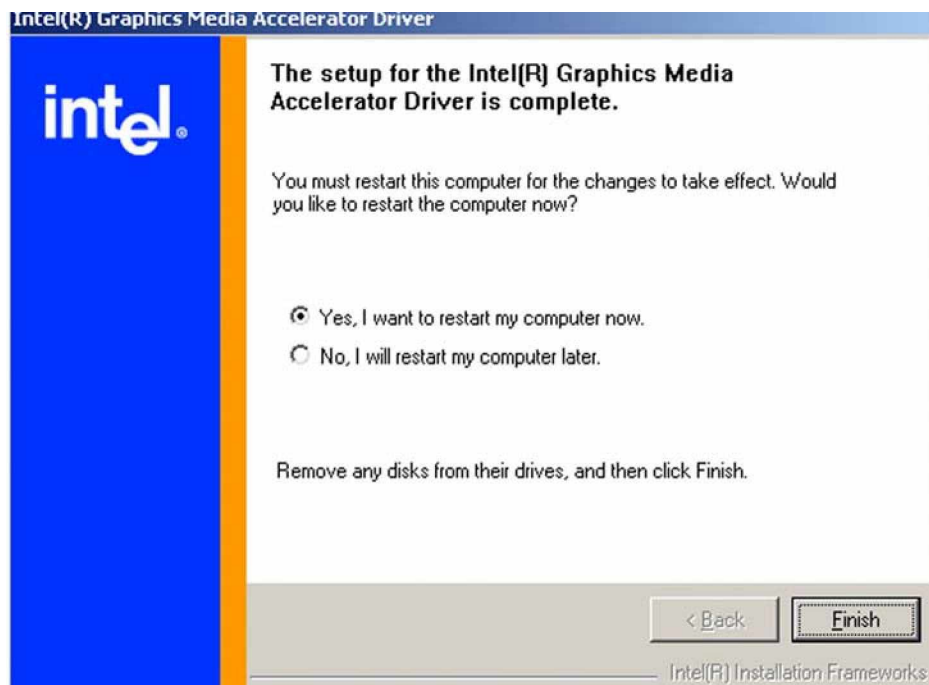

**Figure 6-11: GMA Driver Installation Complete**

**Step 8:** The confirmation screen shown in **Figure 6-11** allows you to restart the computer immediately after the installation is complete or to restart the computer later. For the settings to take effect the computer must be restarted. Once you have decided when to restart the computer, click the “**FINISH**” button. **Step 0:**

## 6.4 RealTek Audio Driver Installation

To install the RealTek AC'97 Audio driver, please follow the steps below:

**Step 1:** Insert the CD into the system that contains the 3301690 CPU card. Open the CD folder and locate the **AUDIO DRIVER A3.79** directory. Open the directory and look for icon for the **setup.exe** installation file. Once located, use the mouse to move the cursor over the icon and double click the mouse button.

**Step 2:** Once you double click the **setup.exe** icon, the install shield wizard for the audio driver starts. See **Figure 6-12**.

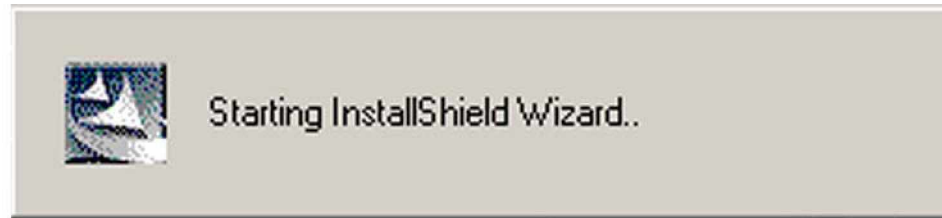

**Figure 6-12: Audio Driver Install Shield Wizard Starting**

**Step 3:** The RealTek Audio Setup prepares the install shield to guide you through the rest of the setup process. See **Figure 6-13**.

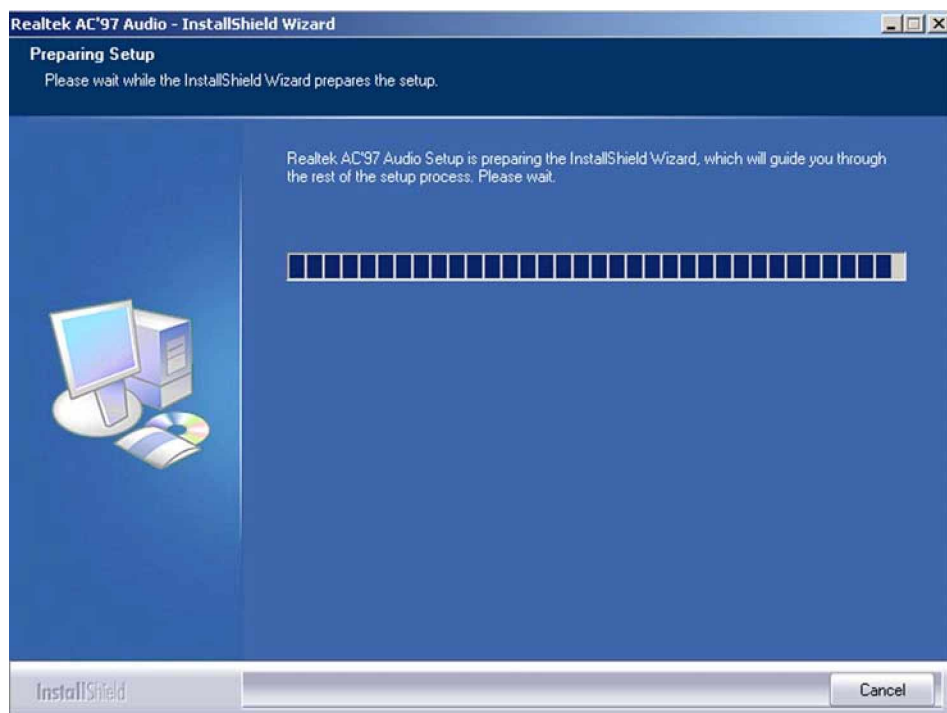

**Figure 6-13: Audio Driver Setup Preparation**

**Step 4:** After install shield is prepared, the welcome screen shown in **Figure 6-14** appears. To continue the installation process, click the **"NEXT"** button. The install shield starts to configure the new software as shown in **Figure 6-15**.

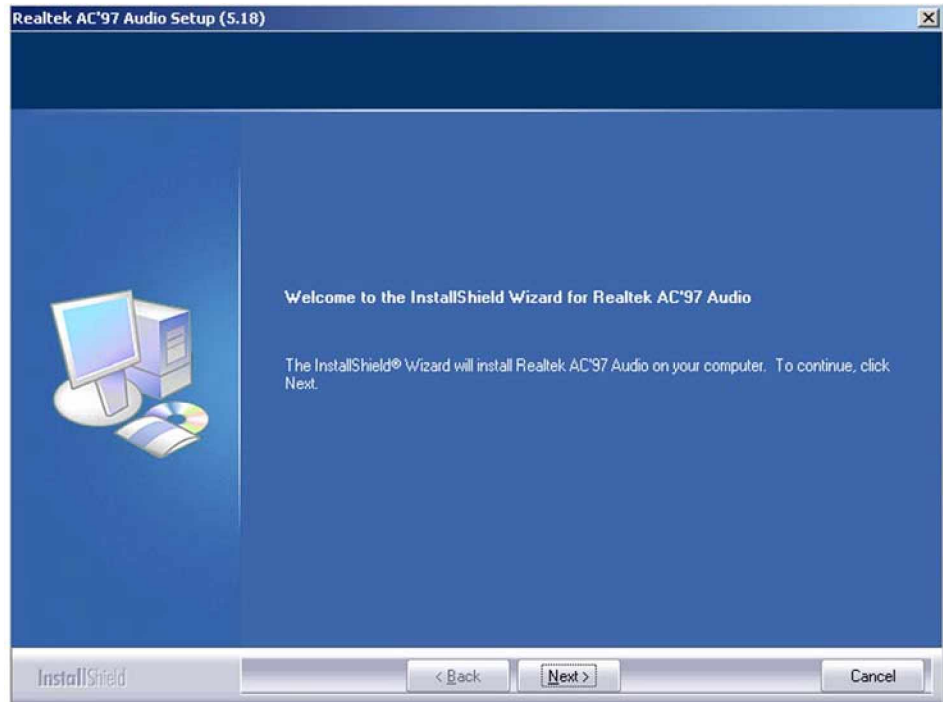

Figure 6-14: Audio Driver Welcome Screen

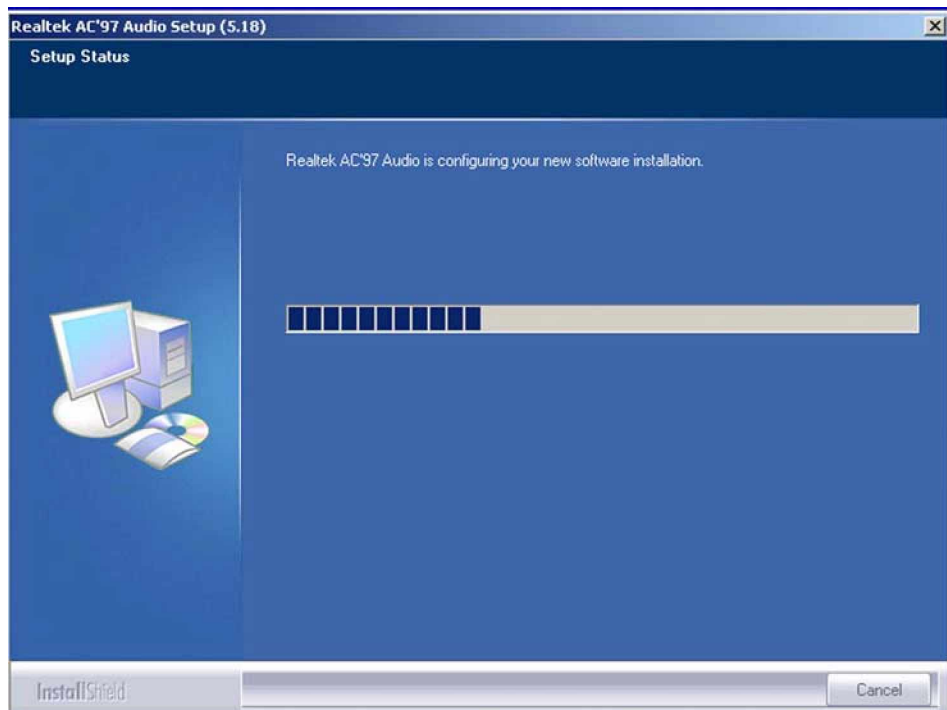

Figure 6-15: Audio Driver Software Configuration

**Step 5:** At this stage the “Digital Signal Not Found” screen shown in Figure 6-16



appears. To continue the installation process click the “**YES**” button. The installation notice shown in **Figure 6-10** will appear.



**Figure 6-16: Audio Driver Digital Signal**

**Step 6:** At this stage the clicking the “**YES**” button in **Figure 6-16** appears, the installation of the driver begins. See **Figure 6-17**.

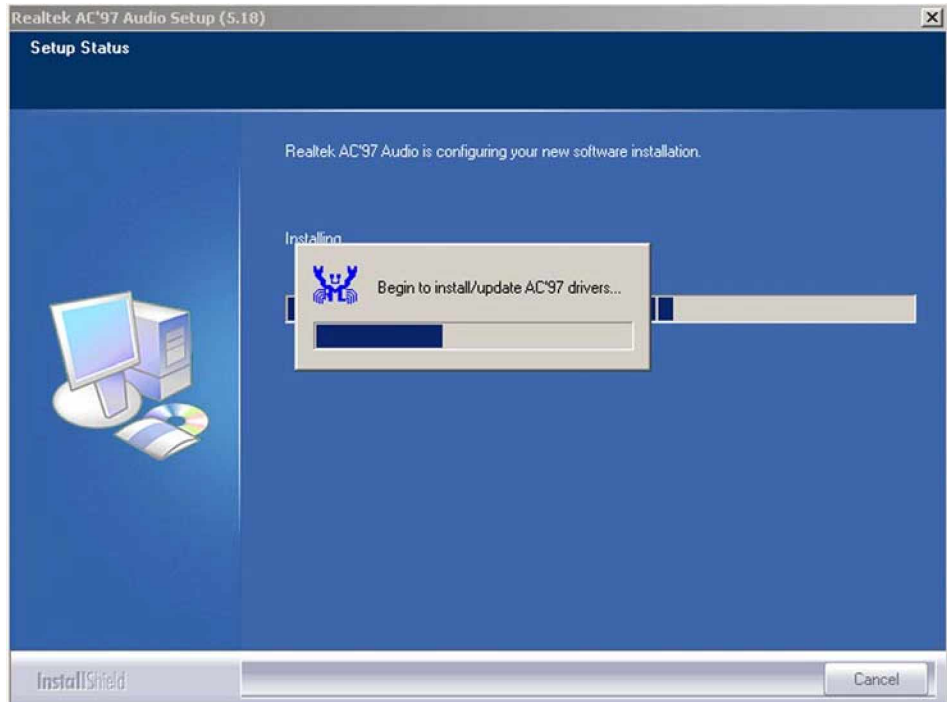

**Figure 6-17: Audio Driver Installation Begins**

**Step 7:** After the driver installation process is complete, a confirmation screen shown in **Figure 6-18** appears

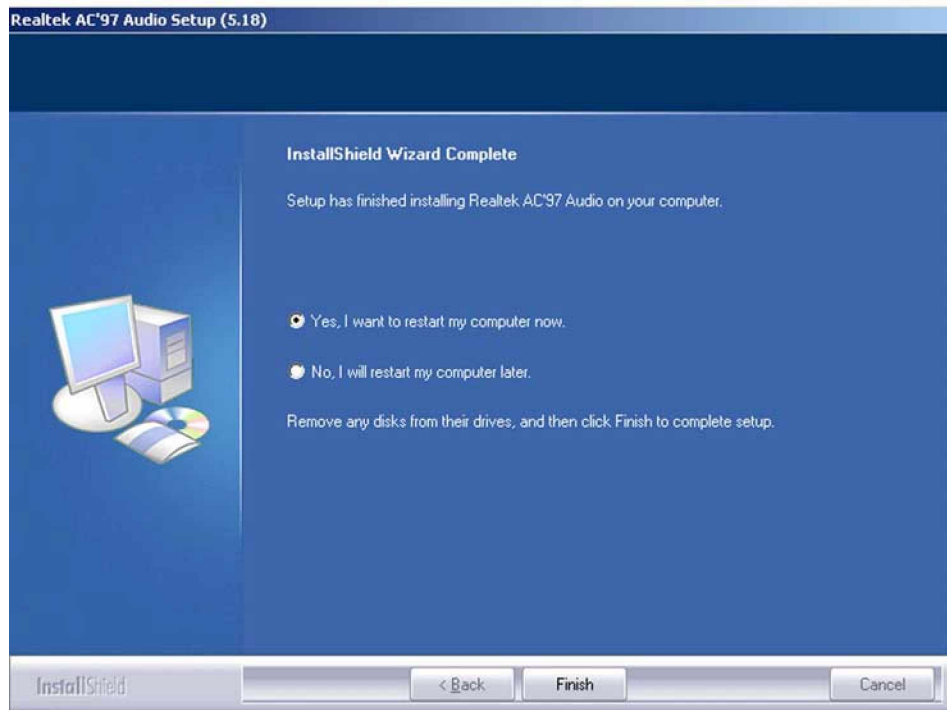

**Figure 6-18: Audio Driver Installation Complete**

**Step 8:** The confirmation screen shown in **Figure 6-18** allows you to restart the computer immediately after the installation is complete or to restart the computer later. For the settings to take effect the computer must be restarted. Once you have decided when to restart the computer, click the “**FINISH**” button. Step 0:

## 6.5 Marvell Gigabit Ethernet Controller Driver Installation

To install the Marvell Gigabit Ethernet controller driver, please follow the steps below:

**Step 1:** Insert the CD into the system that contains the 3301690 CPU card. Open the CD folder and locate the **Mavell 88E8053 Driver \_V84923** directory. Open the directory and look for icon for the **SetupYukonWin.exe** installation file. Once located, use the mouse to move the cursor over the icon and double click the mouse button.

**Step 2:** Once you double click the **SetupYukonWin.exe** icon, the install shield wizard for

the driver is prepared. See **Figure 6-19**.

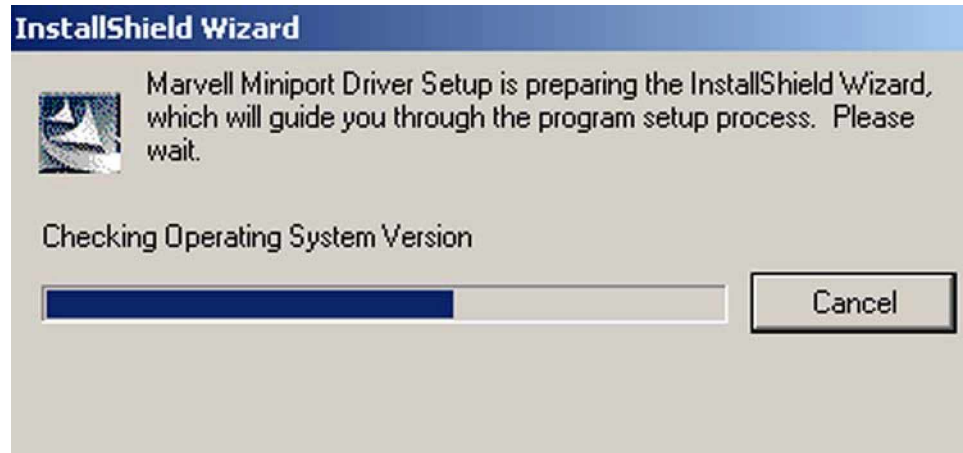

**Figure 6-19: Ethernet Controller Driver Install Shield Wizard Starting**

**Step 3:** After install shield is prepared, the welcome screen shown in **Figure 6-20** appears. To continue the installation process, click the “**NEXT**” button. The license agreement shown in **Figure 6-21** appears.



**Figure 6-20: Ethernet Controller Driver Installation Welcome Screen**

**Step 4:** To continue the installation process, read through the license agreement in **Figure 6-21**, select **"I accept the terms in the license agreement"** click the **"NEXT"** button.



**Figure 6-21: Ethernet Driver License Agreement**

**Step 5:** After clicking the **"NEXT"** button in **Figure 6-21**, the driver is ready to be installed. See **Figure 6-22**.

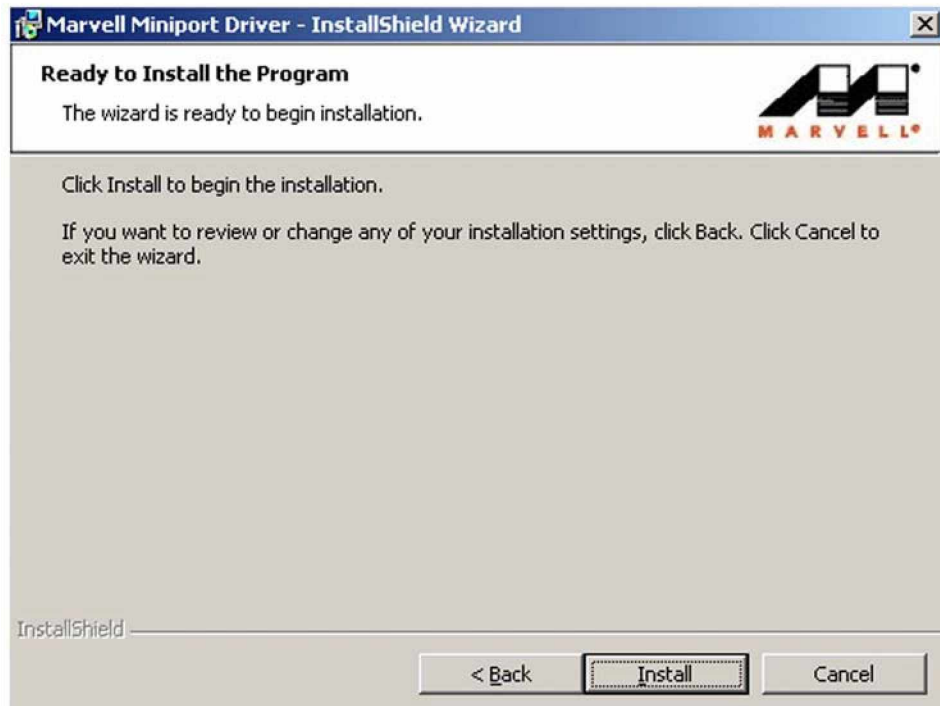

**Figure 6-22: GMA Driver Installing Notice**

**Step 6:** To continue the installation process, click “INSTALL” in **Figure 6-22** and the installation shield begins to install the Ethernet driver. See **Figure 6-23**.

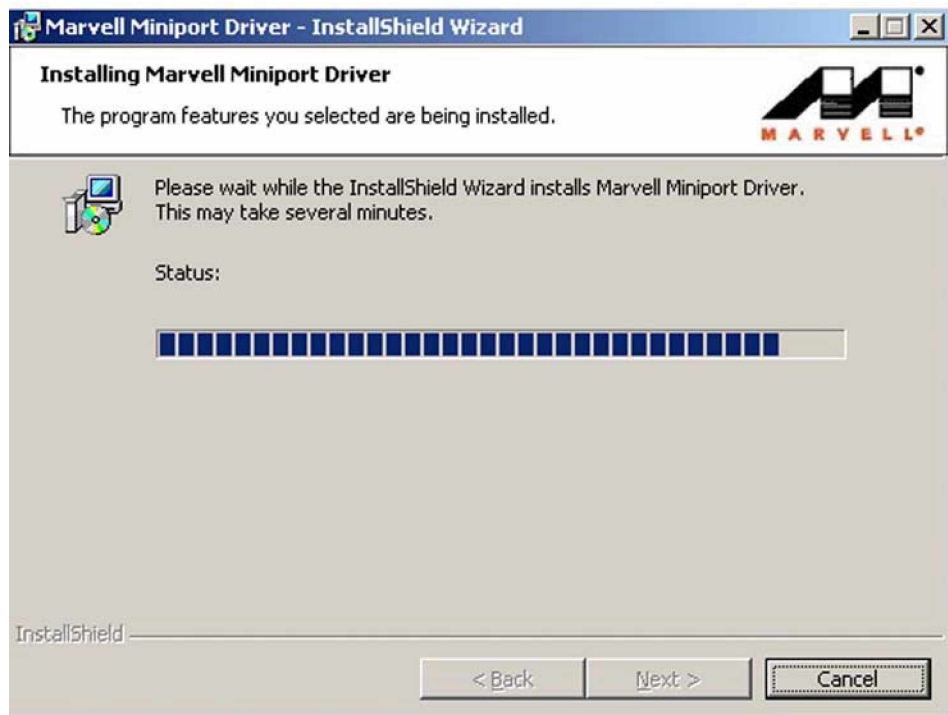

**Figure 6-23: Ethernet Driver is Installed**

**Step 7:** Once the installation is complete and the confirmation screen shown in **Figure 6-24** appears. To exit the shield click the “**FINISH**” button. Step 0:



Figure 6-24: Ethernet Driver Installation Confirmation



Appendix

A

# A BIOS Configuration Options

---

## A.1 BIOS Configuration Options

Below is a list of BIOS configuration options described in **Chapter 5**.

⌈	System Overview .....	78
⌈	Max CUPID Value Limit [Disabled] .....	82
⌈	Execute Disable Bit [Enabled] .....	82
⌈	Hardware Prefetcher [Enabled] .....	82
⌈	Adjacent Cache Line Prefetch [Enabled] .....	82
⌈	Hyper Threading Technology [Disabled] .....	83
⌈	ATA/IDE Configuration [Compatible] .....	84
⌈	Legacy IDE Channels .....	84
⌈	IDE Master and IDE Slave .....	84
⌈	Hard Disk Write Protect [Disabled] .....	84
⌈	IDE Detect Time Out (Sec) .....	85
⌈	ATA (PI) 80Pin Cable Detection [Host & Device] .....	85
⌈	Type [Auto] .....	86
⌈	LBA/Large Mode [Auto] .....	86
⌈	Block (Multi Sector Transfer) [Auto] .....	87
⌈	PIO Mode [Auto] .....	87
⌈	DMA Mode [Auto] .....	87
⌈	S.M.A.R.T [Auto] .....	87
⌈	32Bit Data Transfer [Enabled] .....	87
⌈	On Board Floppy Controller [Enabled] .....	89
⌈	Floppy Drive Swap [Disabled] .....	89
⌈	Serial Port1 Address [3F8/IRQ4] .....	90
⌈	Serial Port1 Mode [Normal] .....	90
⌈	Serial Port2 Address [2F8/IRQ3] .....	90
⌈	Serial Port2 Mode [Normal] .....	90
⌈	Parallel Port Address [Disabled] .....	91
⌈	H/W Health Function [Enabled] .....	92
⌈	ACPI Aware O/S [Yes] .....	94
⌈	Suspend Mode [S1(POS)] .....	95

⌈	MPS Revision .....	96
⌈	Remote Access [Disabled].....	97
⌈	Serial Port Number [COM1] .....	98
⌈	Serial Port Mode [115200 8,n,1].....	98
⌈	Flow Control [None].....	98
⌈	Redirection After BIOS POST [Always] .....	99
⌈	Terminal Type [ANSI] .....	99
⌈	VT-UTF8 Combo Key Support [Disabled].....	99
⌈	USB Configuration.....	100
⌈	USB Devices Enabled: .....	100
⌈	USB Function [8 USB Ports].....	100
⌈	Legacy USB Support [Disabled].....	101
⌈	USB 2.0 Controller [Disabled].....	101
⌈	Clear NVRAM [No].....	103
⌈	Plug & Play O/S [No].....	103
⌈	PCI Latency Timer [64].....	104
⌈	Allocate IRQ to PCI VGA [Yes] .....	104
⌈	IRQ# [Available].....	104
⌈	DMA Channel# [Available] .....	105
⌈	Reserved Memory Size [Disabled] .....	105
⌈	Quick Boot [Enabled] .....	107
⌈	Quiet Boot [Disabled] .....	107
⌈	AddOn ROM Display Mode [Force BIOS] .....	107
⌈	Giga LAN Boot ROM Support [Disabled].....	108
⌈	Bootup Num-Lock [On] .....	108
⌈	PS/2 Mouse Support [Enabled] .....	108
⌈	Wait For 'F1' If Error [Enabled].....	108
⌈	Hit 'DEL' Message Display [Enabled] .....	108
⌈	Interrupt 19 Capture [Disabled].....	108
⌈	Change Supervisor Password.....	111
⌈	Change User Password.....	111
⌈	Boot Sector Virus Protection [Disabled] .....	111

⌈	DRAM Frequency [Auto] .....	114
⌈	Configure DRAM Timing by SPD [Enabled] .....	114
⌈	Memory Hole [Disabled] .....	115
⌈	Boots Graphic Adapter Priority [PCI/IGD] .....	115
⌈	Internal Graphics Mode Select [Enable, 8MB] .....	115
⌈	Aperture Size Select [256MB] .....	115
⌈	DVMT Mode Select [Comob Mode] .....	116
⌈	Boot Display Device [CRT + EFP] .....	117
⌈	Azalia/AC'97 Selection [Enabled] .....	117
⌈	Giga LAN Controller [Enabled] .....	118
⌈	Spread Spectrum Configuration [Disabled] .....	118
⌈	Restore on AC Power Loss [Last State] .....	118
⌈	Power Type [ATX] .....	119
⌈	Power Management/APM [Enabled] .....	119
⌈	Video Power Down Mode [Disabled] .....	119
⌈	Hard Disk Power Down Mode [Disabled] .....	120
⌈	Standby Time Out [Disabled] .....	120
⌈	Suspend Time Out [Disabled] .....	120
⌈	Keyboard & PS/2 Mouse [Monitor] .....	121
⌈	Power Button Mode [On/Off] .....	121
⌈	Resume On Ring [Disabled] .....	121
⌈	Resume On LAN [Disabled] .....	121
⌈	Resume On PME# [Disabled] .....	122
⌈	Resume On RTC Alarm [Disabled] .....	122
⌈	RTC Alarm Date (Days) .....	122
⌈	System Time .....	122
⌈	Save Changes and Exit .....	123
⌈	Discard Changes and Exit .....	123
⌈	Discard Changes .....	123
⌈	Load Optimal Defaults .....	124
⌈	Load Failsafe Defaults .....	124

Appendix

**B**

# **B Watchdog Timer**

---

**NOTE:**

The following discussion applies to DOS environment. It is recommended you visit our website ([www.globalamericaninc.com](http://www.globalamericaninc.com)) for specific drivers for more sophisticated operating systems, e.g., Windows and Linux.

---

The Watchdog Timer is provided to ensure that standalone systems can always recover from catastrophic conditions that cause the CPU to crash. This condition may have occurred by external EMI or a software bug. When the CPU stops working correctly, Watchdog Timer will either perform a hardware reset (cold boot) or a Non-Maskable Interrupt (NMI) to bring the system back to a known state.

A BIOS function call (INT 15H) is used to control the Watchdog Timer:

**INT 15H:**

<b>AH – 6FH Sub-function:</b>	
AL – 2:	Sets the Watchdog Timer's period.
BL:	Time-out value (Its unit-second is dependent on the item "Watchdog Timer unit select" in CMOS setup).

**Table B-1: AH-6FH Sub-function**

You have to call sub-function 2 to set the time-out period of Watchdog Timer first. If the time-out value is not zero, the Watchdog Timer will start counting down. While the timer value reaches zero, the system will reset. To ensure that this reset condition does not occur, calling sub-function 2 must periodically refresh the Watchdog Timer. However, the Watchdog timer will be disabled if you set the time-out value to be zero.

A tolerance of at least 10% must be maintained to avoid unknown routines within the operating system (DOS), such as disk I/O that can be very time-consuming.

**NOTE:**

When exiting a program it is necessary to disable the Watchdog Timer, otherwise the system will reset.

---

Example program:

```

; INITIAL TIMER PERIOD COUNTER
;
W_LOOP:

    MOV    AX, 6F02H    ;setting the time-out value
    MOV    BL, 30      ;time-out value is 48 seconds
    INT    15H

;
; ADD YOUR APPLICATION PROGRAM HERE
;
    CMP    EXIT_AP, 1  ;is your application over?
    JNE    W_LOOP     ;No, restart your application

    MOV    AX, 6F02H   ;disable Watchdog Timer
    MOV    BL, 0       ;
    INT    15H

;
; EXIT ;

```

**This Page is Intentionally Left Blank.**



**Appendix**

**C**

# **C Address Mapping**

---

## C.1 IO Address Map

I/O address Range	Description
000-01F	DMA Controller
020-021	Interrupt Controller
040-043	System time
060-06F	Keyboard Controller
070-07F	System CMOS/Real time Clock
080-09F	DMA Controller
0A0-0A1	Interrupt Controller
0C0-0DF	DMA Controller
0F0-0FF	Numeric data processor
1F0-1F7	Primary IDE Channel
2F8-2FF	Serial Port 2 (COM2)
378-37F	Parallel Printer Port 1 (LPT1)
3B0-3BB	Intel(R) 82915 Graphics Controller
3C0-3DF	Intel(R) 82915 Graphics Controller
3F6-3F6	Primary IDE Channel
3F7-3F7	Standard floppy disk controller
3F8-3FF	Serial Port 1 (COM1)

**Table C-1: IO Address Map**

## C.2 1st MB Memory Address Map

Memory address	Description
00000-9FFFF	System memory
A0000-BFFFF	VGA buffer
F0000-FFFFFF	System BIOS
1000000-	Extend BIOS

**Table C-2: 1<sup>st</sup> MB Memory Address Map**

### C.3 IRQ Mapping Table

IRQ0	System Timer	IRQ8	RTC clock
IRQ1	Keyboard	IRQ9	ACPI
IRQ2	Available	IRQ10	LAN
IRQ3	COM2	IRQ11	LAN/USB2.0/SATA
IRQ4	COM1	IRQ12	PS/2 mouse
IRQ5	SMBus Controller	IRQ13	FPU
IRQ6	FDC	IRQ14	Primary IDE
IRQ7	Available	IRQ15	Secondary IDE

Table C-3: IRQ Mapping Table

### C.4 DMA Channel Assignments

Channel	Function
0	Available
1	Available
2	Floppy disk (8-bit transfer)
3	Available
4	Cascade for DMA controller 1
5	Available
6	Available
7	Available

Table C-4: IRQ Mapping Table

Appendix

**D**

# **D External AC'97 Audio CODEC**

---

### D.1 Introduction

The audio functionalities of the 3301690 CPU card can be implemented using a separately purchased audio module, the AC-KIT08R-R10. The audio kit is powered by a Realtek ALC655, which is a 16-bit, full duplex AC'97 2.3 compatible audio CODEC with 48KHz sampling rate. The audio kit functionalities are interfaced through three (3) phone jack connectors and two (2) pin headers including:

1. A LINE input shared with surround output
2. A MIC input shared with Center and LFE output
3. A LINE output
4. Analog line-level stereo inputs with 5-bit volume control: CDIN1 and AUXIN1.

Both Front\_out and Surround\_out are equipped with a built-in 50mW/20ohm amplifier. The ALC655 supports host/soft audio from Intel ICHx chipsets as well as audio controller based VIA/SIS/Ali/ATI chipset with bundled Windows series drivers (XP/ME/2000/98/NT), EAX/Direct Sound 3D/I3DL2/A3D compatible sound effect utilities supporting Karaoke, 26 kinds of environment sound emulations with 10-band equalizer, and HRTF 3D positional audio. The audio kit provides an excellent entertainment package sufficient for today's multimedia systems.

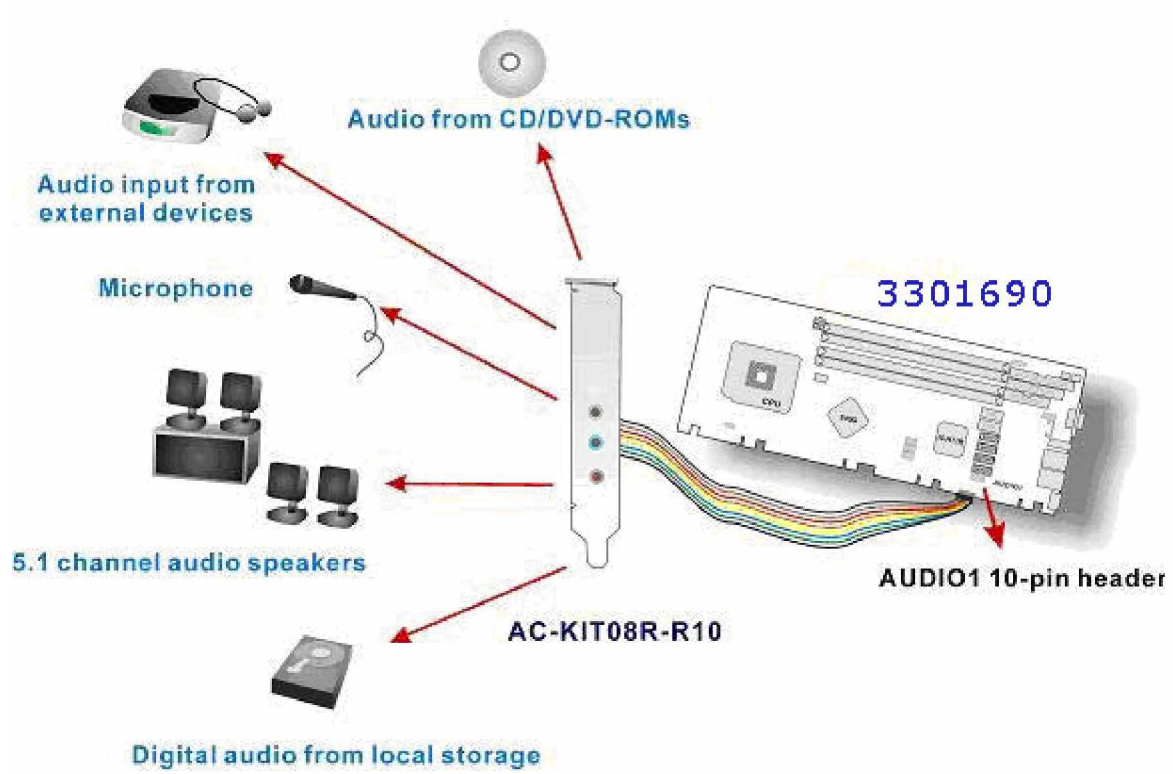

Figure D-1: Audio Functionalities via the Audio Kit

## D.2 Physical Connection

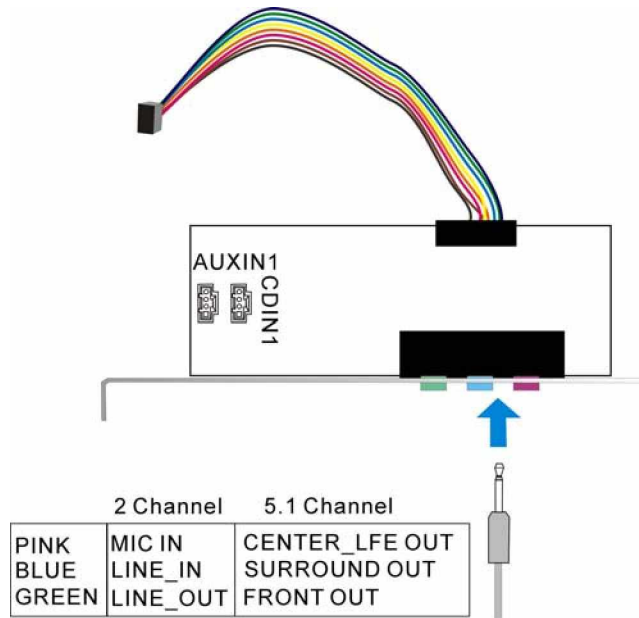

Figure D-2: Audio Kit Connectors

The audio kit comes with a PCI slot bracket for the installation into a PC case or rackmount chassis. Connect the 10-pin header to the 3301570's AUDIO1 header as shown in Figure E-1, and if necessary, connect the CDIN1 and AUXIN1 to optical drives or other audio sources, e.g., an MPEG card, using a 4-pin cable. Note that depending on the devices you connect to, the phone jacks have different functions with different audio installation modes (2 channel or 5.1 channel modes).

### D.3 Driver Installation

The driver installation has been described in **Chapter 6, Section 6.4**.

After reboot, you should be able to find the sound effect configuration utility in Windows Control Panel (see **Figure D-3**); and if peripheral speakers have been properly connected, hear the sound effects.

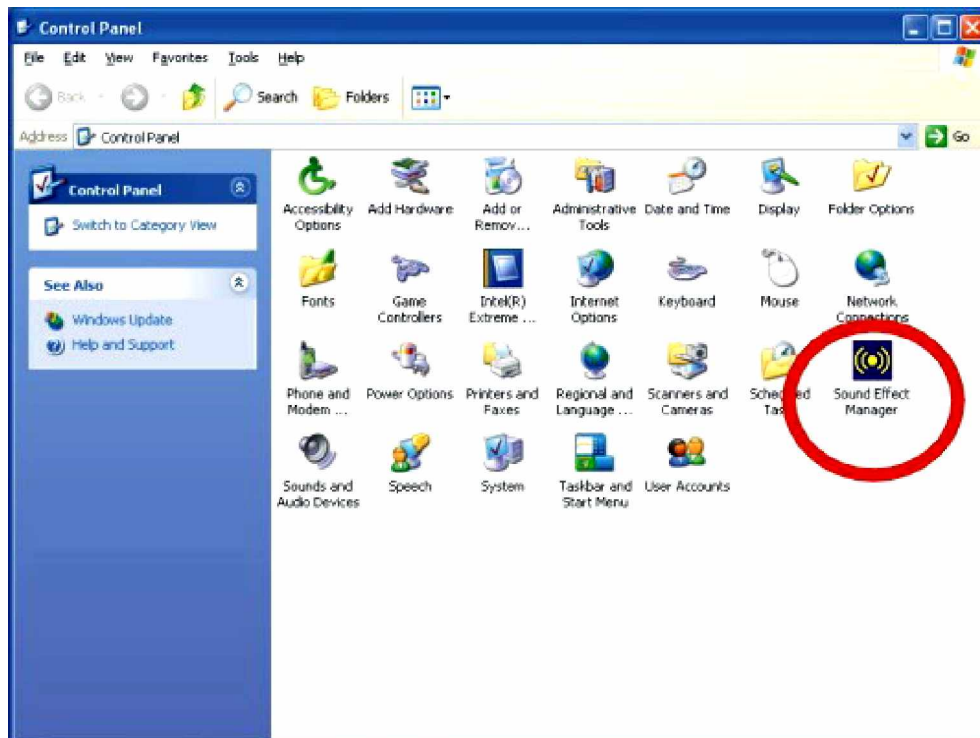

Figure D-3: Sound Effect Manager Icon

## D.4 Sound Effect Configuration

After installing the audio CODEC driver, you should be able to use the multi-channel audio features now. Click the audio icon from the Notification Area from system task bar (see **Figure D-5**). The shortcut to the configuration utility is also available through the **Sound Effect Manager** icon in the **Control Panel** (**Figure D-4**).

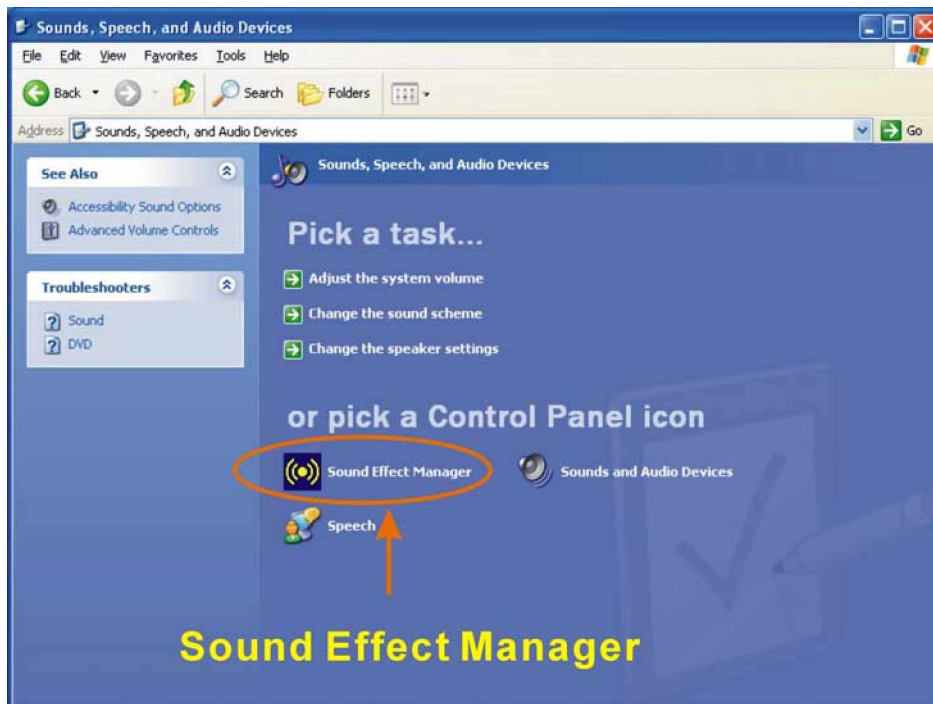

Figure D-4: Sound Effect Manager Icon [Control Panel]

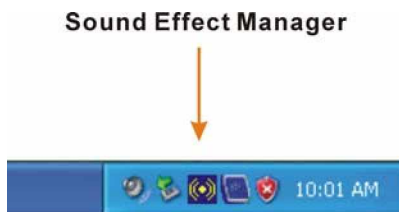
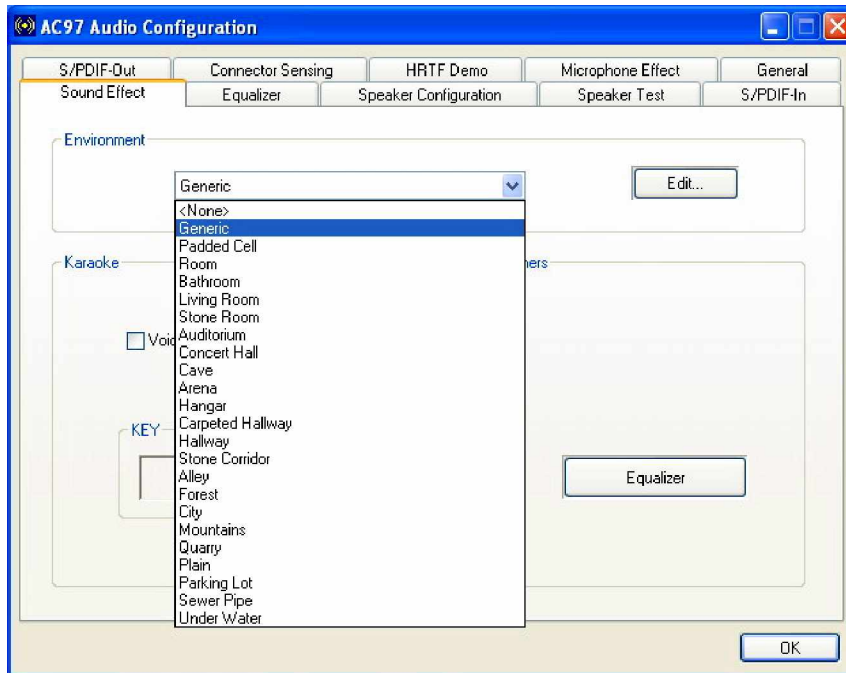

Figure D-5: Sound Effect Manager Icon [Task Bar]



## D.5 Sound Effect

You may select a pre-configured sound environment setting with the preset equalizer settings. You may also load an equalizer setting or make a new equalizer setting using the “**Load EQ Setting**” and “**Save Preset**” button. (See **Figure D-7**)



**Figure D-6: Setting Sound Effects**

## D.6 Environment Simulation

This is the default screen whenever the configuration utility is opened.

You may select different sound environment modes by a single click on the Environment pull-down list. There are a total of 23 preset environment modes (see **Figure D-7**). You may also fine-tune the environment setting by clicking the **Edit** button on the right, which displays an editor window. Select a preset mode you want to edit. Select a preset mode, and then select one the property value from the list below by a single click. Use the scroll bar below to adjust properties setting. When the adjustment is done, click the Save button to proceed.

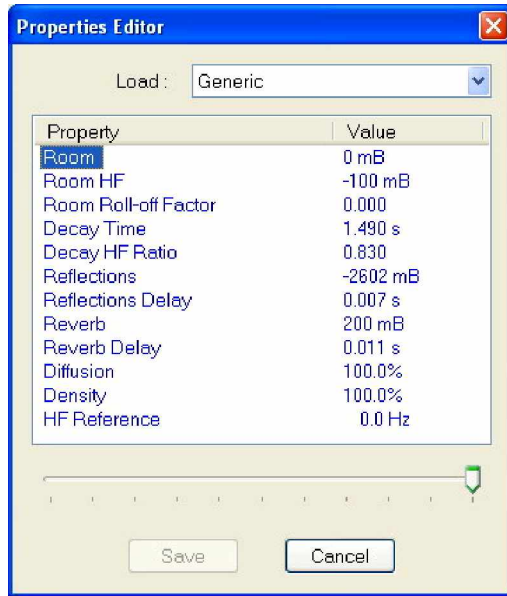

Figure D-7: Sound Effects Properties Editor

## D.7 Karaoke Mode

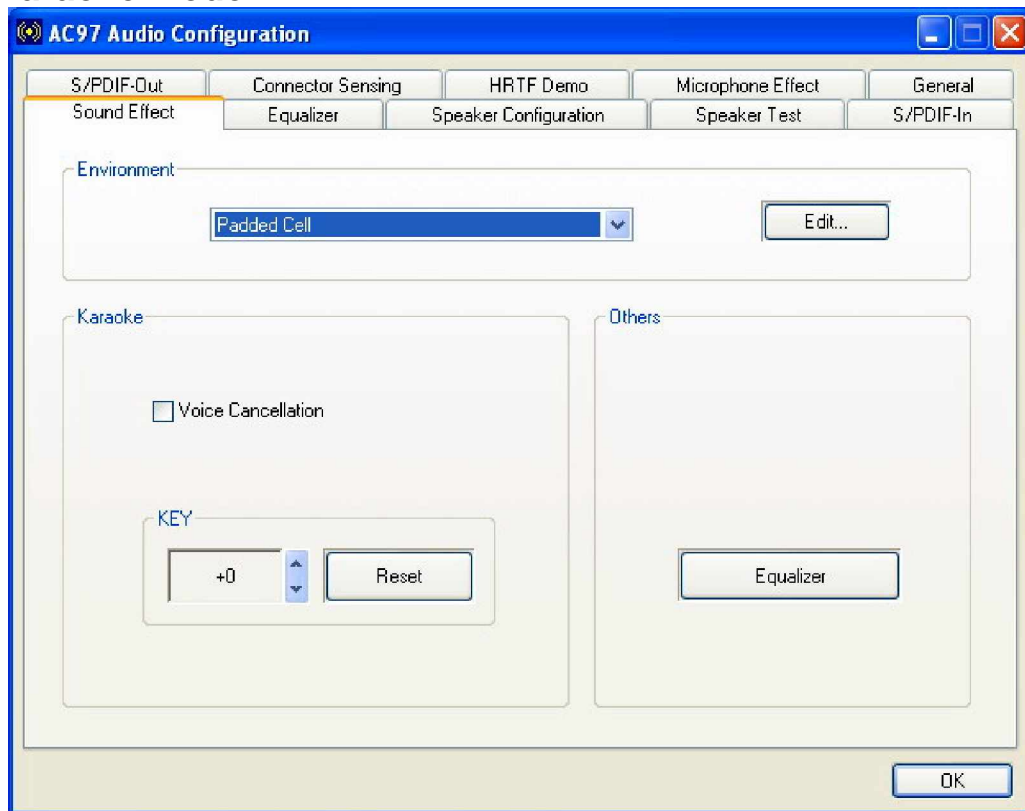

Figure D-8: Karaoke Mode

The Karaoke mode shown in **Figure D-8** allows you to eliminate the vocal of the music you play or adjust the key to accommodate your range.

The configuration options that come with the Karaoke function include:

1. **Voice Cancellation:** This checkbox, when selected, disables the vocal part of the music your play in your computer while the background music remains.
2. **Key adjustment:** Use the Up or Down arrow icons to find a key that fits your vocal range.



### NOTE:

The Equalizer button on the default display brings you to the same configuration window as the Equalizer function tab on top of the window.

---

## D.8 Equalizer Selection

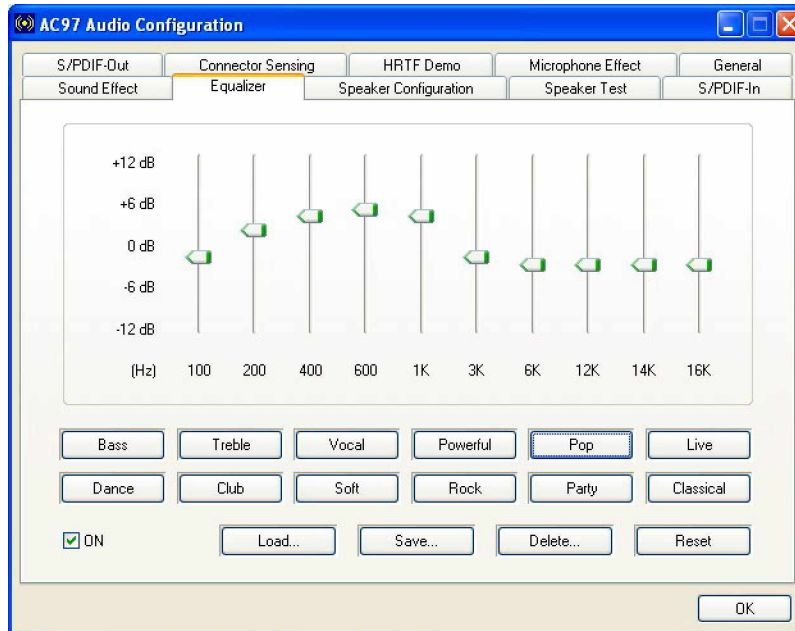

**Figure D-9: Equalizer Settings**

The equalizer in **Figure D-9** allows users to change sound effect parameters. The default screen shows equalized values. You may also select preset modes from the buttons below. The configurable values include 10 bands of equalizer ranging from 100Hz to 16KHz. Use the scroll bar to fine-tune, and use the **Load**, **Save**, **Delete**, and **Reset** buttons to edit your settings.

## D.9 Speaker Configuration

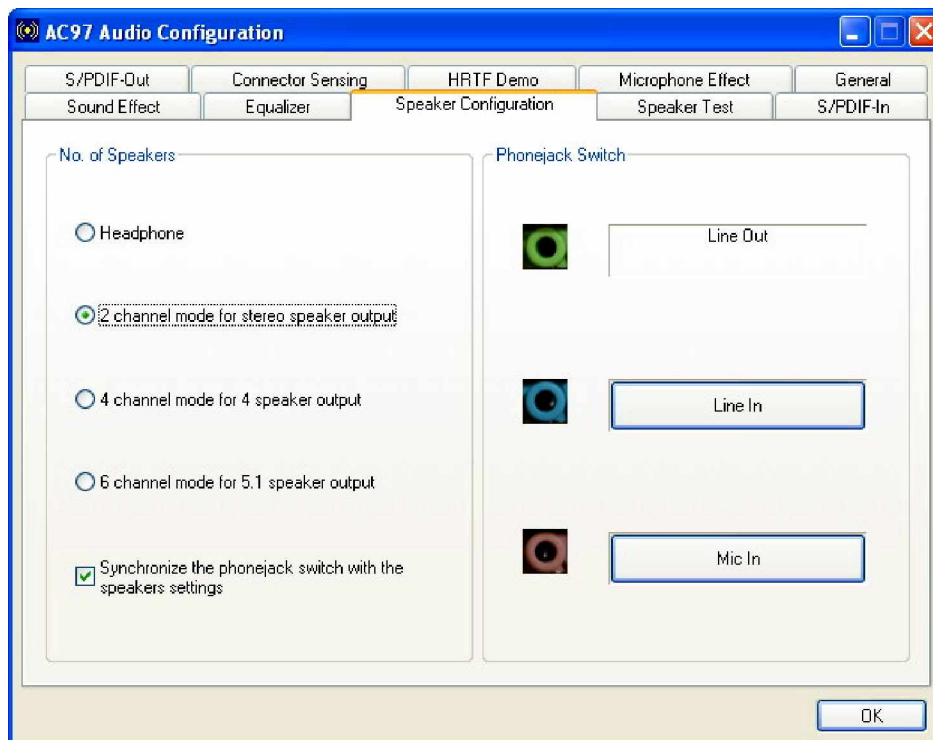

**Figure D-10: Speaker Configuration**

In this functional window, you can configure your multi-channel speaker settings.

Select the audio configuration from the **No. of Speakers** section on the left by clicking on one of the check circles.

The configurable options are:

1. Headphone

2. Channel mode for stereo speaker output
3. Channel mode for 4 speaker output
4. Channel mode for 5.1 speaker output
5. Synchronize the phonejack switch with speakers settings

Select a speaker configuration by selecting its check circle, and then click **OK** to apply the configuration change.

Connect your speakers to the corresponding phonejacks. It is recommended you write down your configuration, power off the system, and then complete the physical connections.

Select from the **Phonejack Switch** section if you want to re-define the phonejacks. Click the specific phonejack button for several times to change its input/output functionality.

## D.10 Speaker Test



Figure D-11: Audio Configuration

The audio configuration window in **Figure D-11** allows you to test each connected speaker to see if your 4-channel or 6-channel audio operates properly. If any speaker malfunctions, you should then check the cabling or replace the malfunctioning parts.

Select each specific speaker to test its functionality. The speaker you select will be highlighted and sound should be generated.



### NOTE:

1. The test scenario that appears in the **Speaker Test** window corresponds to the number of speakers you selected in the **Sound Effect** window.
  2. You should select and deselect the **Swap Center/Subwoofer Output** check box to see if these two devices properly work.
- 

## D.11 S/PDIF-In & S/PDIF-Out

These functions are currently not supported.

## D.12 Connector Sensing

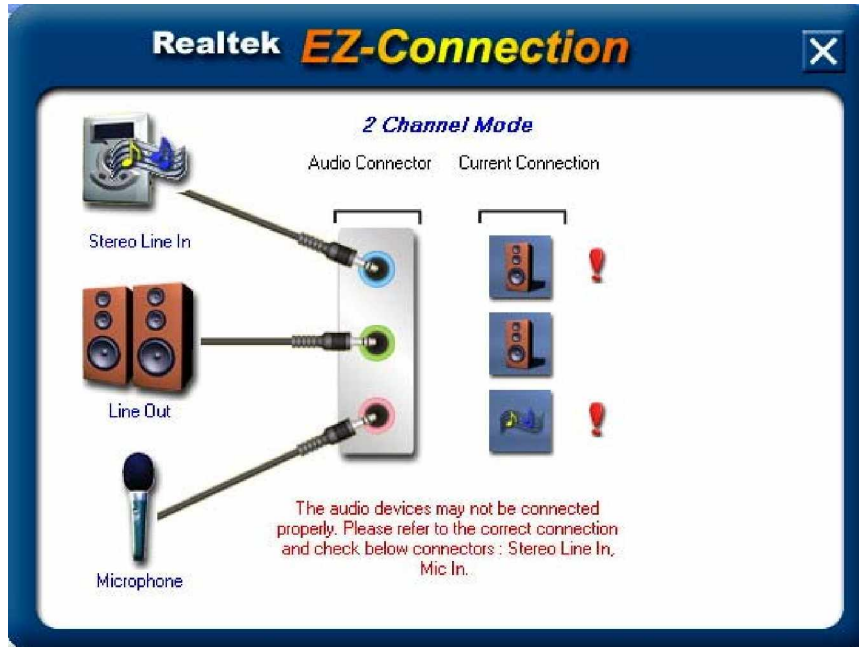

**Figure D-12: Connector Sensing**

Realtek ALC655 supports Jack Sensing functionality. If an audio device is plugged into the wrong connector, a warning message will display informing users to correct the physical connections.

Click the Start button in **Figure D-12** to start the sensing. Please remember to close all running audio-related programs before executing the sensing operation.

The EZ-Connection screen in **Figure D-13** shows the result of sensing test.

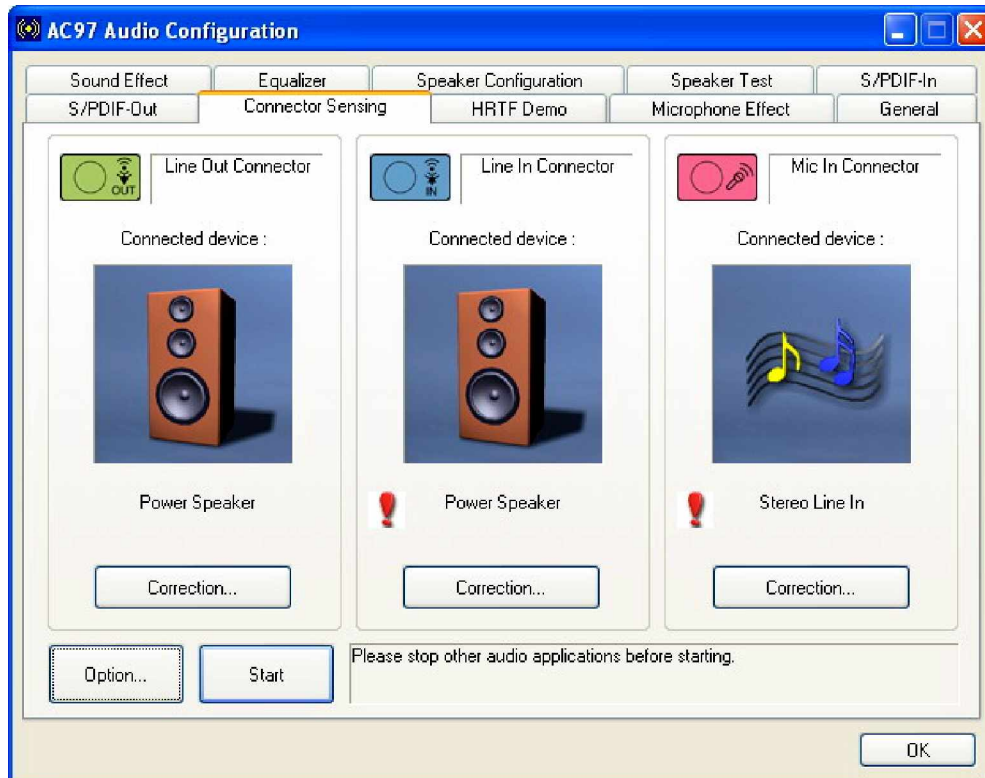

**Figure D-13: EX Connection**

The "Audio Connector" column shows the settings used in the "Speaker Configuration" window.

The "Current Connection" column shows the types of devices detected during test. If the result does not match the physical connection, an exclamation mark will appear. (See **Figure D-14**)

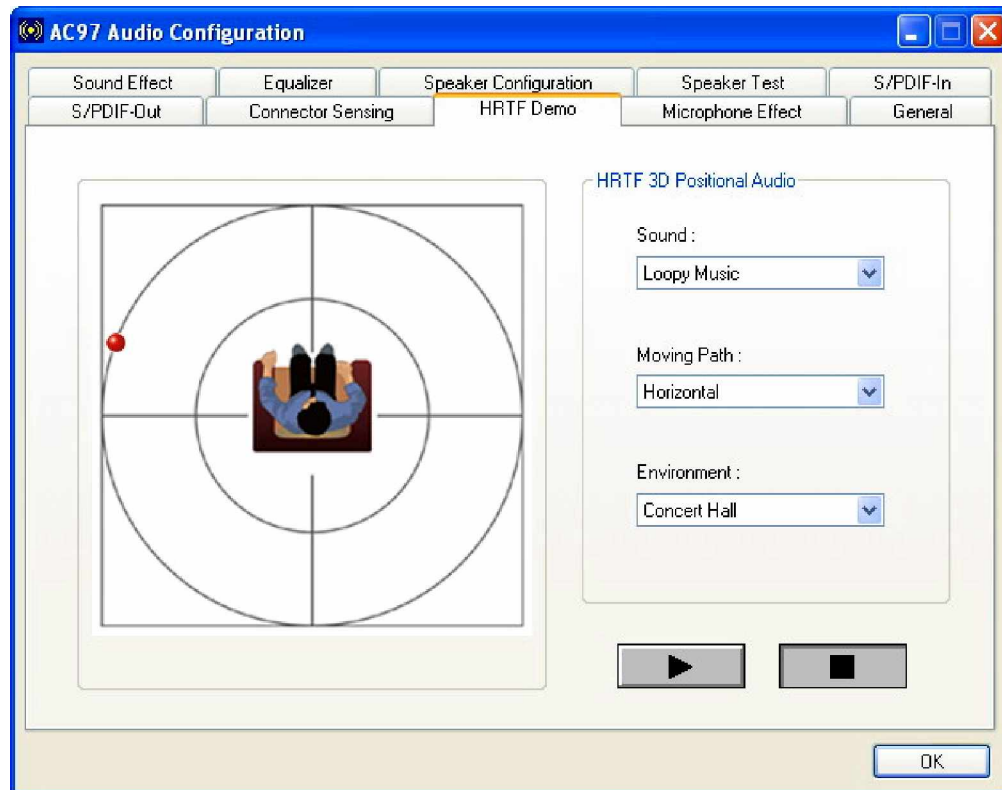



**Figure D-14: Connector Sensing Test Result**

After closing the EZ-Connector screen, the following window should appear showing the latest connection status.

## D.13 HRTF Demo



**Figure D-15: HRTF Demo**

The HRTF window in **Figure D-15** allows you to adjust your HRTF (Head Related Transfer Functions) 3D positional audio before playing 3D applications. Select a preferred **Environment** mode and/or different **Sound** and **Moving Path** settings.

## D.14 Microphone Effect

This window provides an option, Noise Suppression. Select its check box to enable this functionality.

## D.15 General

The general window in **Figure D-16** provides information about this AC'97 audio configuration utility including **Audio Driver** version, **DirectX** version, **Audio Controller**, and **AC'97 Codec**. You may also change the language of this utility through the **Language** pull-down menu.

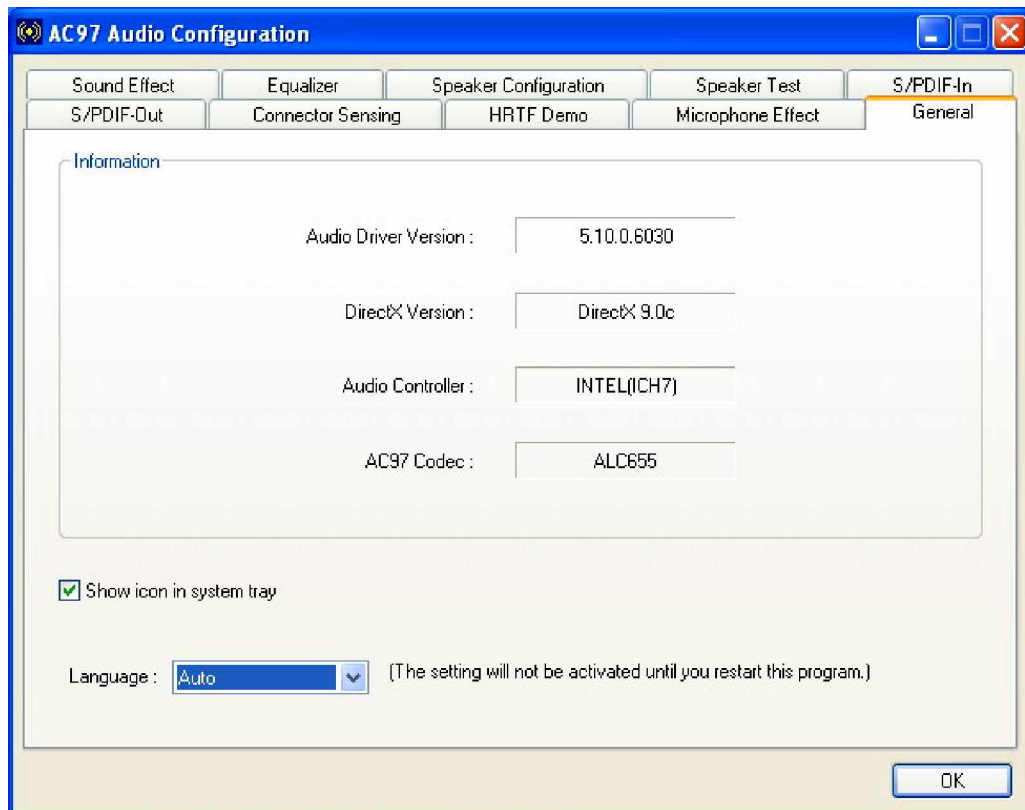

**Figure D-16: General**

# E Index

---

**A**

ACPI, 6, 12, 13, 17, 21, 93, 94, 95, 146, 154  
Address Mapping, 6, 152, 171  
AMI flash BIOS, 17, 26  
ASKIR, 13, 25, 44  
ATA, 13, 16, 17, 21, 24, 27, 30, 64, 72, 84, 85, 146  
ATX connector, 31  
ATX-12V power supply, 54

**B**

battery voltage, 25  
BIOS, 4, 5, 6, 10, 11, 12, 13, 15, 17, 25, 26, 41, 59  
bus masters, 23

**C**

Celeron, 3, 15, 17, 20  
chassis speaker, 43  
chipset driver, 126, 129  
Chipsets, 3, 17, 21  
CMOS RAM, 17, 25  
CN13, 74  
CN2, 74  
CODEC, 7, 26, 30, 51, 126, 155, 156, 159  
cooling fan, 26, 40, 65, 68, 92  
Cooling fans, 17  
cooling kit, 65, 68, 69, 73  
CPU 12V power source, 68  
CPU board, 2, 15, 17, 20, 22, 24, 25, 26, 27, 31, 35, 48, 51, 55, 64, 68  
CPU card, 20, 26, 31, 55, 62, 63, 64, 70,

71, 72, 73, 126, 130, 134, 139, 156

**D**

daisy-chain, 31  
data flow, 22  
DDR2, 15, 17, 21, 23, 70  
digital input output, 38  
digital visual interface, 48  
DIMM, 70  
DIMM module, 70, 72  
DIMM modules, 65, 70, 72, 73  
DIO, 4, 8, 10, 13, 30, 38, 39  
DOS environment, 150  
dual channel, 15  
DVI function, 27  
Dynamic Display Modes, 23

**E**

Environment Simulation, 7, 160  
Ethernet, 74  
Example program, 151  
Execute Disable Bit, 20, 81, 82, 146

**F**

FDD, 3, 4, 8, 10, 13, 16, 17, 24, 27, 30, 31, 32, 64, 72, 73, 89  
FDD1, 73  
Floppy, 73  
Floppy Disk Drive, 3, 13, 17, 24  
front panel, 30, 43  
FSB, 13, 15, 20, 26, 81

**G**

Gigabit Ethernet, 6, 15, 17, 23, 24, 139  
gigabit Ethernet controller driver, 126

graphics core, 22  
Graphics Media Accelerator, 6, 17, 21,  
126, 130

### H

hardware acceleration, 22  
HDD, 3, 13, 17, 24, 30, 33, 43, 72, 73,  
120  
HDD Interface, 17  
Head Related Transfer Functions, 169  
heat sink, 26  
heatsink, 68  
HT Technology, 20, 21, 65  
Hyper-Threading Technology, 20, 65

### I

IDE, 72  
IDE channel, 17  
Intel® 915GV, 3, 17, 21, 22  
Intel® GMA 900, 17, 22  
Intel® ICH6, 3, 17, 21, 23  
IrDA, 4, 8, 10, 13, 16, 17, 25, 30, 44, 45,  
90, 91

### J

Jack Sensing, 166

### K

Karaoke mode, 162

### L

LAN connectivity, 24  
LAN ports, 24  
LCD Panel, 74  
LGA 775, 15, 20, 22  
LGA775, 2, 8, 15, 65, 66, 68

load lever, 66  
load plate, 66  
LPT, 8, 10, 13, 16, 27, 30, 37

### M

maximum resolution, 23  
memory bandwidth, 22  
Microphone Effect, 7, 169  
mini jumper, 27, 64

### N

Northbridge, 3, 12, 17, 21, 116

### P

parallel port, 36  
PCI Bus Interface, 3, 17, 23  
PCI Express, 3, 15, 17, 21, 23  
Pentium 4, 2, 15, 26, 65  
peripheral connectors, 31, 55, 73  
PIO IDE, 24  
Power Button Mode, 121  
power switch, 43  
Pre-Boot Execution Environment, 26  
Prescott, 3, 15, 17, 20  
protective cover, 66  
PS/2 mouse and keyboard connectors, 55  
PS2, 16, 27, 64, 72

### R

Real Time Clock, 3, 17, 25  
reset button, 43  
Reset CMOS Jumper, 5, 59  
Resume On LAN, 121  
Resume On PME#, 122  
RJ-45 Connector, 30  
RJ-45 Ethernet connector, 57

RoHS, 15  
RPM, 25  
RS-232, 16, 17, 25, 27, 30, 64, 72

### **S**

SATA cable, 27, 64  
SATA controller, 21  
SATA data transfer rate, 46  
SATA drive ports, 46  
SATA drives, 24  
SATA power cable, 27, 46, 64, 72  
SATAII, 16  
Serial Infrared, 13, 25  
Serial Ports, 3, 17, 25  
Shift Keyed Infrared, 13, 25  
SIR, 13, 25, 44  
SMIBIOS, 26  
software drivers, 126  
Sound Effect Manager, 158, 159  
sound environment, 160  
Southbridge, 3, 17, 21  
SpeedStep, 13, 20, 82  
Suspend Time Out, 120  
System Bus, 21  
system voltages, 17, 91, 93

### **T**

technical specifications, 17  
temperature, 17, 26, 91  
thermal paste, 26, 69

### **U**

UART, 13, 25, 35  
Unpacking, 5, 63  
USB, 4, 5, 6, 8, 10, 12, 13, 15, 16, 17, 21,  
25, 26, 27, 30, 39, 40, 55, 56, 64, 72,  
74, 99, 100, 101, 147, 148

### **V**

VGA connector, 55, 58  
video memory, 23  
Virtual Cable Tester, 24

### **W**

Watchdog Timer, 6, 149, 150, 151  
3301690, 2, 3, 4, 5, 8, 15, 16, 17, 20,  
23, 24, 25, 26, 27, 29, 31, 48, 51, 55,  
59, 62, 63, 64, 65, 68, 70, 72, 126, 130,  
134, 139, 156

### **Y**

Y cable, 27, 64, 72

Any advice or comments about our products and service, or anything we can help you with please don't hesitate to contact with us. We will do our best to support you for your products, projects and business

### **Global American Inc.**

Address: 17 Hampshire Drive  
Hudson, NH 03051

TEL: Toll Free (U.S. Only) 800-833-8999  
(603)886-3900

FAX: (603)886-4545

Website: <http://www.globalamericaninc.com>

E-Mail: [salesinfo@globalamericaninc.com](mailto:salesinfo@globalamericaninc.com)

