



3302011

User's Manual

Version 1.0

5.25" Embedded Eden Little board with VIA Eden 533 MHz CPU, w/ (1) 168-Pin DIMM Slot For Up To 512MB SDRAM, w/Flat Panel / CRT VGA, Dual LAN, Audio, PC104+, 4 COM / 2 LPT, CFC

Copyright

Copyright© 2002, 2003. All rights reserved. This document is copyrighted and all rights are reserved. The information in this document is subject to change without prior notice to make improvements to the products.

This document contains proprietary information and ~~protected~~ by copyright. No part of this document may be reproduced, copied, or translated in any form or any means without prior written permission of the manufacturer.

All trademarks and/or registered trademarks contains in this document are property of their respective owners.

Disclaimer

The Company shall not be liable for any incidental or consequential damages resulting from the performance or use of this product.

The Company does not issue a warranty of any kind, express or implied, including without limitation implied warranties of merchantability or fitness for a particular purpose. The company has the right to revise the manual or include changes in the specifications of the product described within it at any time without notice and without obligation to notify any person of such revision or changes.

Trademark

All trademarks are the property of their respective holders.

Packing List

Hardware

3302011 Single Board Computer X 1

Cable Kit

IDE Flat Cable (UltraDMA/33)..... X 1
FDD Cable X 1
2 x COM / 1 x LPT Port DB9 / DB25 Cable..... X 2
Dual-USB Port Cable with Bracket..... X 2
PS/2 Keyboard and Mouse Cable X 1
UltraATA/100 IDE Cable X 1
VGA DB15 Female Cable X 1
Audio Cable X 1
LAN RJ45 Cable X 2

Printed Matter and Software

Driver CD with User's Manual X 1

Table of Content

Chapter 1. Introduction	5
1.1 Product Overview	5
1.2 Specifications	6
1.3 Component Placement.....	9
Chapter 2. Hardware Setup.....	11
2.1 Jumpers and Connectors Location.....	11
2.2 CPU and DRAM Setting	14
2.3 CMOS Setting	14
2.4 Watchdog Timer Setting	15
2.5 Embedded Flash Disk	16
2.6 Power and Fan Connectors.....	17
2.7 VGA Interface	18
2.8 Ethernet Interface.....	23
2.9 Audio Interface	24
2.10 Multiple I/O Port Configuration	25
2.11 Expansive Bus Interfaces.....	27
2.12 Switches and Indicators	28
Chapter 3. BIOS Setup	29
3.1 Flat Panel Type Setting	30
Chapter 4. Driver Installation	33
4.1 Install Board's Software	33
4.2 Install Ultra ATA IDE Driver	33
4.3 Install VGA Driver	33
4.4 Install LAN Driver	33
4.5 Install Audio Driver	33
4.6 Link to < Website > Homepage	33
4.7 Browse this CD.....	33

Appendix A. I/O Port Pin Assignment.....	35
A.1 IDE Port	35
A.2 FDD Port	37
A.3 Serial and Parallel Port	38
A.4 USB Port	39
A.5 IrDA Port	39
A.6 PS/2 Keyboard and Mouse Port.....	39
Appendix B. Flash the BIOS	40
B.1 BIOS Auto Flash Tool	40
B.2 Flash Method	40
Appendix C. System Resources	41
C.1 I/O Port Address Map.....	41
C.2 Memory Address Map	42
C.3 System IRQ and DMA Resource.....	43
Contact Information	46

Chapter 1. Introduction

1.1 Product Overview

The **3302011** Single Board Computer is an all-in-one industrial 5.25" drive-size EBX-compliant little board computer based on VIA EBGA Eden/C3 embedded / low power 686-level processor. The onboard VIA EBGA Eden CPU offers 667/533/400 MHz of speed at the low voltage to provide the low power embedded computing platform for low power, an free, mobile and related applied / embedded computing applications.

3302011 integrates onboard 256/128 MB PC133 SDRAM, LVDS/TTL flat panel SVGA, dual 10/100BASE-Tx Fast Ethernet, AC97 3D audio, CompactFlash solid state disk, UltraATA/100 PCI enhanced IDE interfaces, and multiple I/O ports including 4 RS232, 2 LPT and 4 USB ports. These features make 3302011 be the ideal solution of industrial workstation, node terminal, transaction station, POS, Kiosk, panel PC, ATM and embedded application.

Based on VIA Eden platform, **3302011** features the high computing capacity and high integration with onboard CPU, SDRAM. LVDS flat panel SVGA, audio, dual LAN, CompactFlash interfaces, and 4 COM, 2 LPT, 4 USB ports. With these features, 3302011 provides the powerful performance and integrated solutions including, but not limited to the following.

Compact Low Profile Board Size

5.25" drive size meets the industrial standard EBX form factor. The onboard CPU and SDRAM also make 3302011 be the low profile solution for embedded compact applications.

Advanced Embedded Computing Platform

VIA Eden embedded CPU supports up to 667 MHz at 133 MHz FSB with onboard 256 MB PC133 SDRAM of system memory for high-end industrial embedded computing platform with high CPU and memory loading.

Flat Panel SVGA Interface

Integrated VIA/S3 Savage4 flat panel SVGA controller with LVDS/TTL flat panel interface offers the high 3D performance for LCD-based applications.

Multiple I/O Port Interface

Integrated 4 COM, 2 parallel, 4 USB ports for industrial applications like POS, Kiosk, Panel PC, ATM and transaction workstation.

1.2 Specifications

General Specification

Form Factor	5.25" drive-size EBX compliant littleboard computer
CPU	VIA Eden 533 MHz CPU at 133 MHz FSB Low power / fan free x86 computing platform Optional Eden 667/400 or C3 800 MHz CPU for OEM
Chipset	VIA PN133T with 8606 and 686B
DRAM	Onboard optional 128/256 MB PC133 SDRAM 1 x 168-pin DIMM slot supports 512 MB PC133 SDRAM Total memory capacity up to 768 MB PC133 SDRAM
BIOS	Phoenix-Award 2Mb PnP flash BIOS
Enhanced IDE	PCI enhanced IDE interface supports dual ports up to 4 ATAPI devices with UltraATA/100 supported One 40-pin box header connector One 44-pin box header connector
Green Function	Power saving mode supported in BIOS with DOZE, STANDBY and SUSPEND modes. ACPI version 1.0 and APM version 1.2 compliant
Watchdog Timer	6-level generates NMI or system reset programmable watchdog timer
Real Time Clock	VIA 686B built-in RTC with lithium battery

Multi-I/O Ports

Chipset	VIA 686B built-in super I/O controller Winbond W83977EF-AW for COM3/4 and LPT2 Ports
Serial Port	Three RS-232 serial port COM1/3/4 and one jumper selectable RS-232/422/485 serial port COM2. Both with 16C550 compatible UART and 16 bytes FIFO +5V/+12V power output for RS232 peripherals
USB Port	Four USB ports with USB version 1.1 compliant
Parallel Port	Two bi-direction parallel port with SPP/ECP/EPP mode
FDD	1 x FDD port supports up to two FDD
IrDA Port	1 x IrDA compliant Infrared interface supports SIR
K/B & Mouse	PS/2 keyboard and mouse ports

Solid State Disk Interface

Flash Type	CompactFlash Type-II for CFC (Compact Flash Card) or IBM MicroDrive
Capacity	Up to 1 GB flash memory

Display Interface

Chipset	VIA 8606 built-in S3 Savage4 3D SVGA controller
Video Memory	Up to 32 MB of video memory shared with system memory, selectable in BIOS
Display Type	LVDS/TTL flat panel / CRT and LCD monitor at VGA, SVGA, XGA, SXGA, UXGA

Ethernet Interface

Chipset	Dual 10/100BASE-Tx Fast Ethernet LAN interfaces with PCI RTL8100B controller
Type	10Base-T / 100Base-TX, auto-switching Fast Ethernet, full duplex, IEEE802.3U compliant

Audio Interface

Chipset	VIA 686B integrated AC97 3D audio controller with onboard codec
Interface	Line-in, line-out, CD-in, Mic-out
Connector	Onboard 10-pin header connector for line-in, line-out and Mic-out

Expansive Interface

PCI Bus	One 32-bit/33 MHz PCI slot with 2 x bus master PCI via an additional riser card
PC/104-plus	One PC/104-plus interface with 32-bit PCI-based 120-pin PC/104-plus interface and 16-bit ISA-based 104-pin PC/104 interface

Power and Environment

Power Req.	+5V, +12V DC input on standard 4-pin AT connector
ATX Function	One 3-pin ATX interface with 5V standby
Dimension	146 x 203 mm or 5.75" x 8" (L x W), standard EBX size
Temperature	Operating within 0 ~ 60°C (32 ~ 140°F) Storage within -20 ~ 85°C (-4 ~ 185°F)

Ordering Code

3302011	With VIA Eden 533MHz CPU, SVGA. Audio, Dual LAN, CompactFlash, PC/104+ Interface and 4 COM Ports
---------	--

1.3 Component Placement

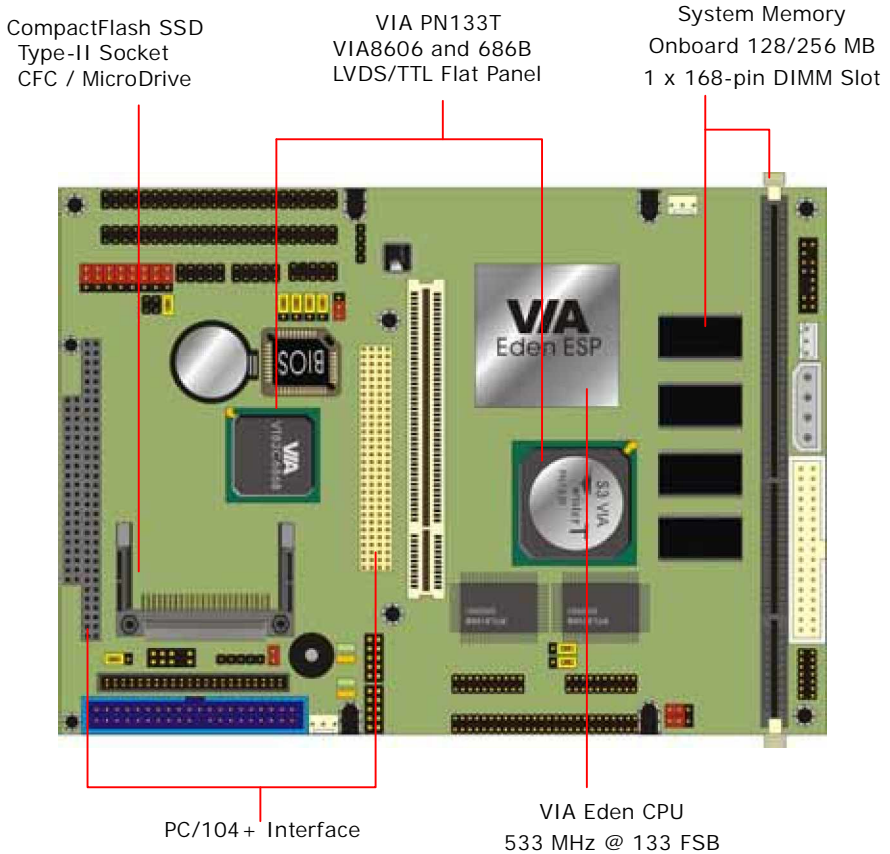

Notes (This page left blank intentionally)

A large, empty rectangular box with a thin black border, occupying most of the page. It is intended for the user to write notes.

Chapter 2. Hardware Setup

This chapter contains the information for installation of hardware. The install procedure includes jumper settings, CPU and memory installation, fan, I/O and panel connections.

2.1 Jumpers and Connectors Location

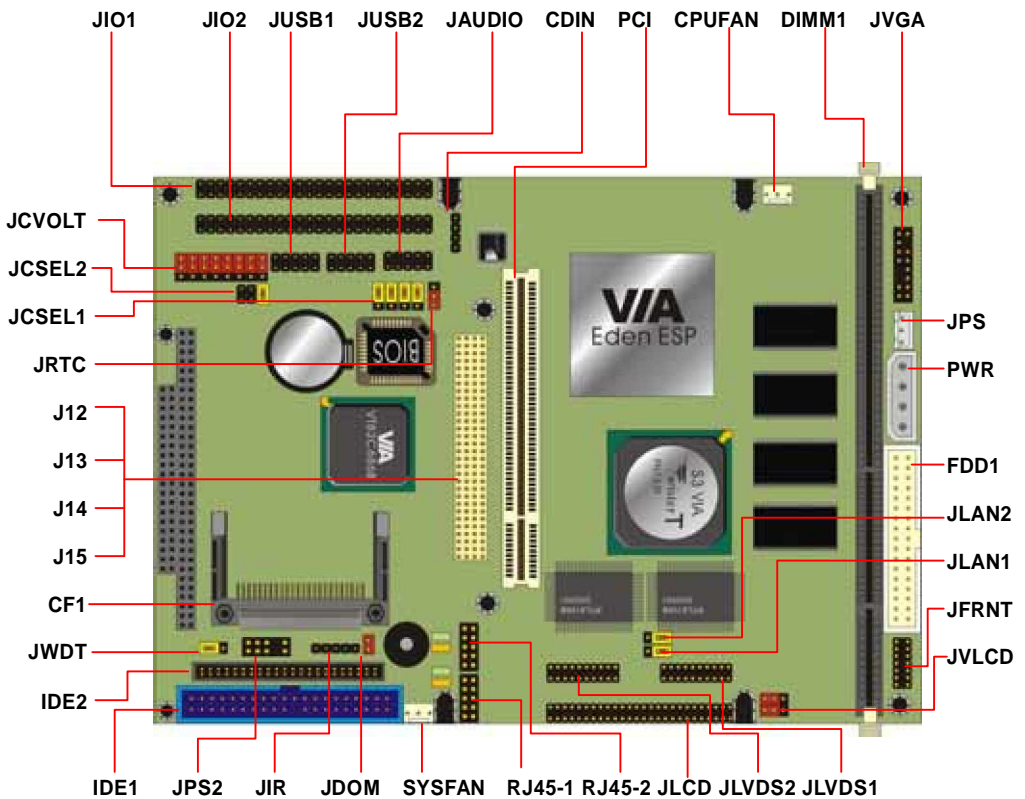

2.1.1 Jumpers Reference

Jumper	Function	Section
JRTC	COMS Setting	2.3
JWDT	Watchdog Timer Setting	2.4
SWDT	Time Out Value of Watchdog Timer Setting	2.4
JDOM	DiskOnModule SSD Setting	2.5
JVLCD	Flat Panel's Voltage Setting	2.7.2
JVSAFE	Flat Panel's Power Safe Setting	2.7.2
JLAN1	Primary LAN Enable/Disable Setting	2.8
JLAN2	Secondary LAN Enable/Disable Setting	2.8
JCSEL1	COM2 RS-232/422/485 Mode Setting	2.10.1
JCSEL2	COM2 RS-232/422/485 Mode Setting	2.10.1
JCVOLT	RS232 Serial Port +5/+12V Power Setting	2.10.2

2.1.2 Connectors Reference

Connector	Function	Remark
DIMM1	168-pin DIMM Slot	Standard
IDE1	40-pin Primary IDE Port	Standard
IDE2	44-pin Secondary IDE Port	Standard
FDD1	34-pin FDD Port	Standard
JIO1	50-pin Primary 2S/1P I/O Port	Standard
JIO2	50-pin Secondary 2S/1P I/O Port	Standard
JUSB1	10-pin 1st / 2nd USB Port	Standard
JUSB2	10-pin 3rd / 4th USB Port	Standard
JCF	Compact Flash Socket	Standard
JPS2	10-pin PS/2 Keyboard / Mouse Connector	Standard
JIR	5-pin SIR IrDA Port	Standard
PWR	4-pin AT Power Connector	Standard
JPS	3-pin ATX Signal Connector	Standard
JFRNT	14-pin Switch and Indicator Connector	Standard
CPUFAN	3-pin CPU Fan Connector	Standard
SYSFAN	3-pin System Fan Connector	Standard
JVGA	16-pin Internal VGA Port	Standard
JLCD	50-pin TTL Flat Panel Interface	Standard
JLVDS1	20-pin 1st LVDS Flat Panel Interface	Standard
JLVDS2	20-pin 2nd LVDS Flat Panel Interface	Standard
JAUDIO	10-pin Audio Port	Standard
CDIN	4-pin CD-in Interface	Standard
RJ45-1	10-pin Primary LAN Port Connector	Standard
RJ45-2	10-pin Secondary LAN Port Connector	Standard
PCI1	32-bit PCI Slot	Standard
PC104	104-pin PC/104 Connector	Standard
J12~15	120-pin PC/104-plus Connector	Standard

2.2 CPU and DRAM Setting

The board is integrated with VIA embedded EBGA Eden 533 MHz CPU at 133 MHz FSB.

System memory including onboard 128/256 MB PC133 SDRAM and one 168-pin DIMM slot up to 512 MB SDRAM. Total memory capacity up to 768 MB PC133 SDRAM.

2.3 CMOS Setting

The board's data of CMOS can be setting in BIOS. If the board refuses to boot due to inappropriate CMOS settings, here is how to proceed to clear (reset) the CMOS to its default values.

Jumper: JRTC

Type: onboard 3-pin header

JRTC	Mode
1-2	Clear CMOS
2-3	Normal Operation

Default setting

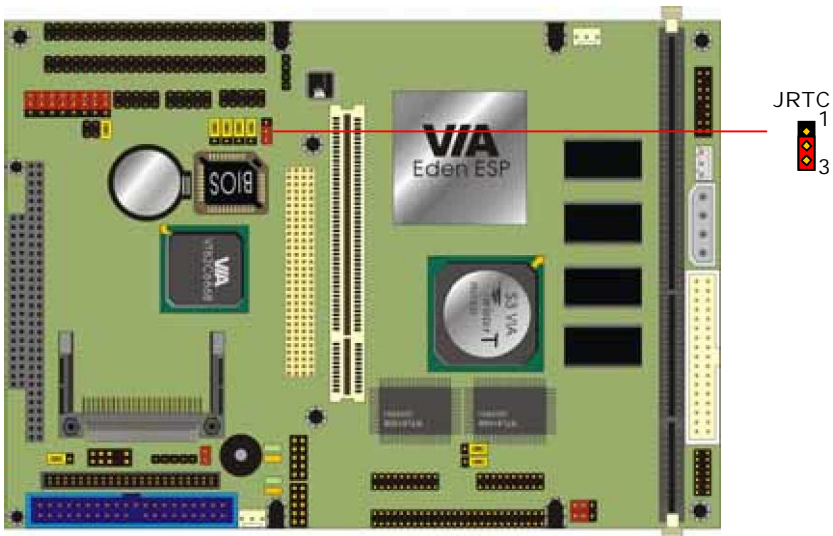

2.4 Watchdog Timer Setting

The watchdog timer makes the systems auto-reset while it stop to work for a period. The onboard watchdog timer can be set as system reset or active NMI mode by jumper JWDT1; the timeout value can be set as 1, 2, 10, 20, 110, or 220 seconds by jumper SWDT1.

Jumper: JWDT

Type: onboard 3-pin header

JWDT	Watchdog Timer
1-2	Active NMI
2-3	Reset

Default setting

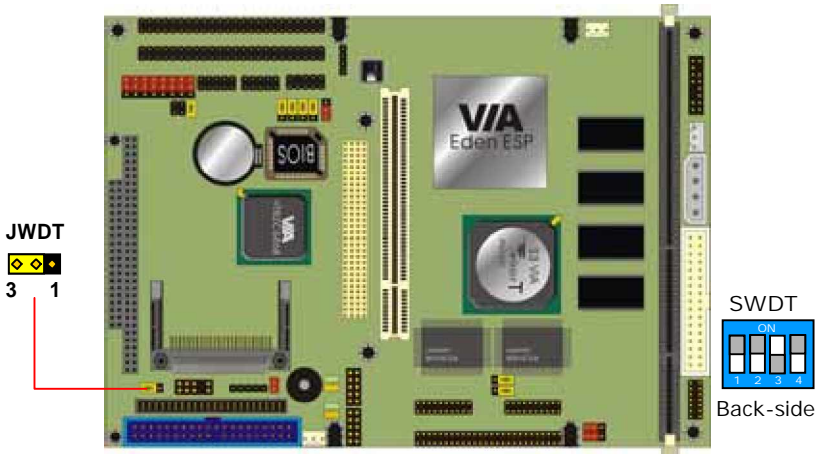

Jumper: SWDT

Type: onboard 4-button / 2-level DIP switch (backside)

Timeout Value	SWDT	1	2	3	4
1 Second		OFF	OFF	ON	OFF
2 Seconds		OFF	OFF	ON	ON
10 Seconds		OFF	ON	OFF	OFF
20 Seconds		OFF	ON	OFF	ON
110 Seconds		ON	OFF	OFF	OFF
220 Seconds		ON	OFF	OFF	ON

Default setting

2.5 Embedded Flash Disk

The board supports both IDE-based DiskOnModule and CompactFlash embedded Solid State Disk (SSD).

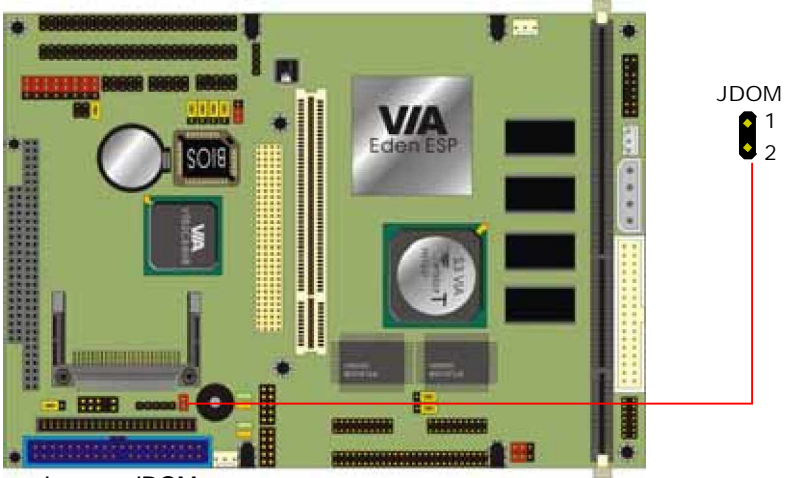

Jumper: JDOM

Type: onboard 2-pin header

JDOM	+5V on Pin-20 of IDE1
OFF	Disable
ON	Enable

Default setting

2.6 Power and Fan Connectors

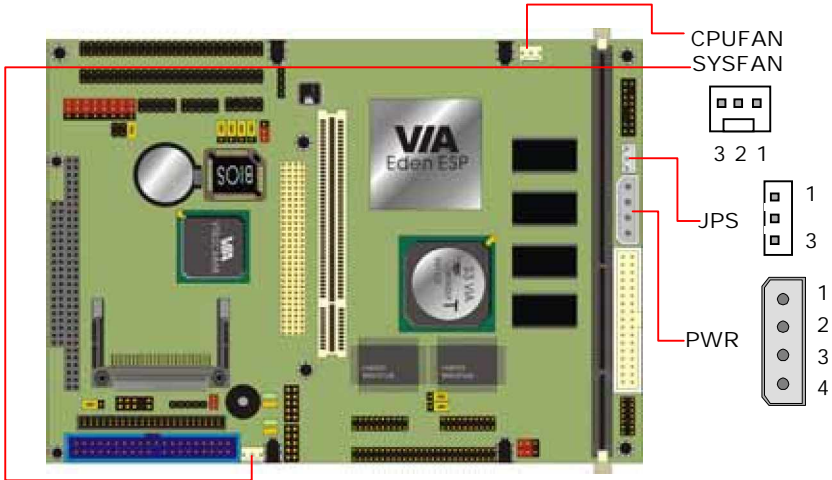

Connector: PWR

Type: 4-pin AT Power Connector

Pin	Description	Cable Color Reference
1	+12V	Yellow
2	Ground	Black
3	Ground	Black
4	+5V	Red

Connector: JPS

Type: 3-pin ATX Function Connector

Pin	Description	Pin	Description	Pin	Description
1	5V Standby	2	Ground	3	Power On

Connector: SYSFAN, CPUFAN

Type: 3-pin Fan Power Wafer Connector

Pin	Description	Pin	Description	Pin	Description
1	Ground	2	+12V	3	Fan Control

2.7 VGA Interface

2.7.1 Standard Analog VGA Interface

The board is integrated with VIA PN133T chipset's built-in 4xAGP S3 Savage4 VGA accelerator with 3D/2D engine and 32 MB of video memory shared with system memory.

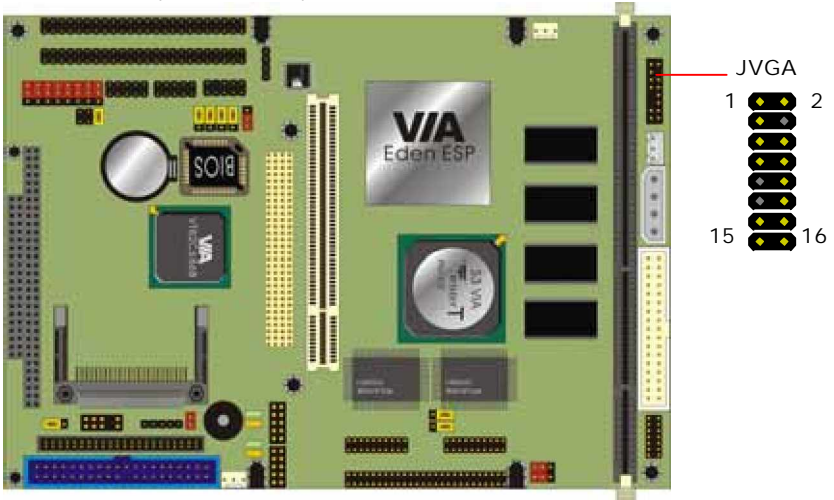

Connector: JVGA
Type: 16-pin header

Pin	Description	Pin	Description
1	Red	2	Green
3	Blue	4	N/C
5	Ground	6	Ground
7	Ground	8	Ground
9	N/C	10	Ground
11	N/C	12	Data
13	HSYNC	14	VSYNC
15	Clock	16	N/C

2.7.2 Digital VGA Interface

The board's digital video interface provides both of TTL and LVDS for different types of flat panel. The built-in 18-bit dual channel LVDS interface offers the economical solution for LVDS-based LCD display. All of the digital video interfaces used BIOS selectable 8/16/32 MB of video memory shared with system memory.

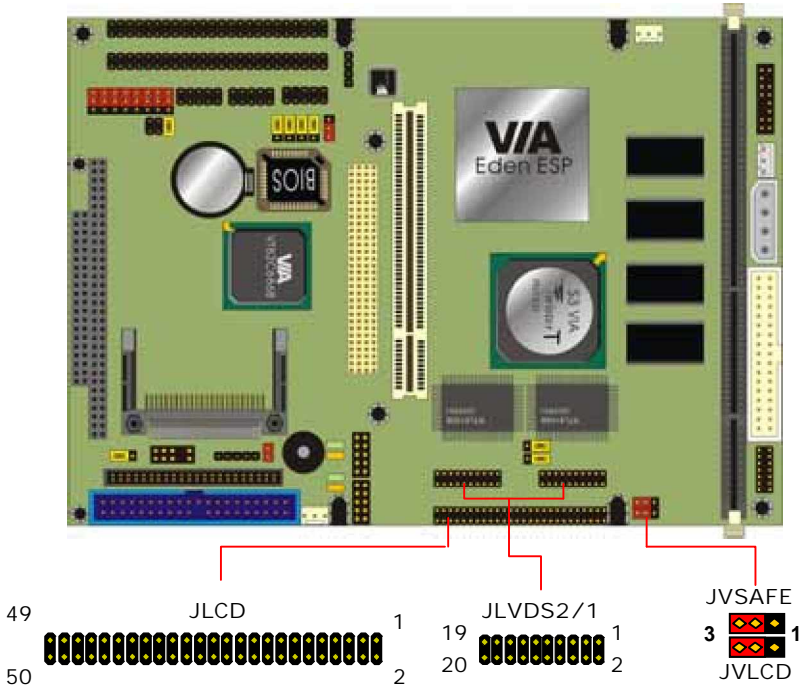

Jumper: **JVLCD**

Type: onboard 3-pin (1 x 3) header

JVLCD	LCD Voltage Setting
1-2	+5V
2-3	+3.3V

Default setting

Jumper: **JVSAFE**

Type: onboard 3-pin (1 x 3) header

JVSAFE	LCD Power Sequence Control
1-2	Power Input Directly
2-3	Power Sequence Control by Chipset (VIA VT8606)

Default setting

Connector: **JLCD**

Type: onboard 50-pin (2 x 25) 2.0 pitch header

Pin	Signal	Pin	Signal
1	+12V	2	+12V
3	GND	4	GND
5	V _{CC} (LCD)	6	ENAVDD
7	ENAVEE	8	GND
9	P0	10	P1
11	P2	12	P3
13	P4	14	P5
15	P6	16	P7
17	P8	18	P9
19	P10	20	P11
21	P12	22	P13
23	P14	24	P15
25	P16	26	P17
27	P18	28	P19
29	P20	30	P21
31	P22	32	P23
33	P24	34	P25
35	SHFCLK	36	FLM
37	DE	38	LP
39	GND	40	ENABKL
41	P26	42	P27
43	P28	44	P29
45	P30	46	P31
47	P32	48	P33
49	P34	50	P35

Connector: **JLVDS1, JLVDS2**

Type: onboard 20-pin (2 x 10) 2.0mm pitch header

Pin	Signal	Pin	Signal
1	LCD_Vcc	2	+12V
3	GND	4	GND
5	TA-	6	TA+
7	GND	8	TB-
9	TB+	10	GND
11	TC-	12	TC+
13	GND	14	TCLK-
15	TCLK+	16	GND
17	N/C	18	N/C
19	ENABKL	20	GND

2.7.3 BIOS Configuration for Flat Panel

The selection of display type for flat panel depends on the LCD display you use. Please enter the “Advanced Chipset Features” screen on the main screen and find the item of “Panel Type”, and set it with the specification of the flat panel.

Panel Type	Support Function
00	640x480 TFT
01	800x600 TFT
02	1024x768TFT 2 pixel/clock at 32Mhz
03	1280x1024 TFT
04	640x480 DSTN
05	800x600 DSTN
06	1024x768 DSTN
07	1024x768 TFT 1 pixel/clock at 65Mhz
08	640x480 TFT
09	800x600 TFT
0A	1024x768 TFT
0B	1280x1024 TFT
0C	1400x1050 TFT 2 pixel/clock at 54Mhz
0D	800x600 DSTN
0E	1024x768 DSTN
0F	1280x1024 DSTN

2.8 Ethernet Interface

The board integrated with 10/100BASE-TX Fast Ethernet interface at the type of 10Base-T/100Base-TX auto-switching Fast Ethernet with full duplex and IEEE 802.3U compliant. The LAN controller, RTL8100B provides the powerful Fast Ethernet interface with embedded operating system (OS) supported, green function (power saving mode / wake-on-LAN) and advanced network management functions.

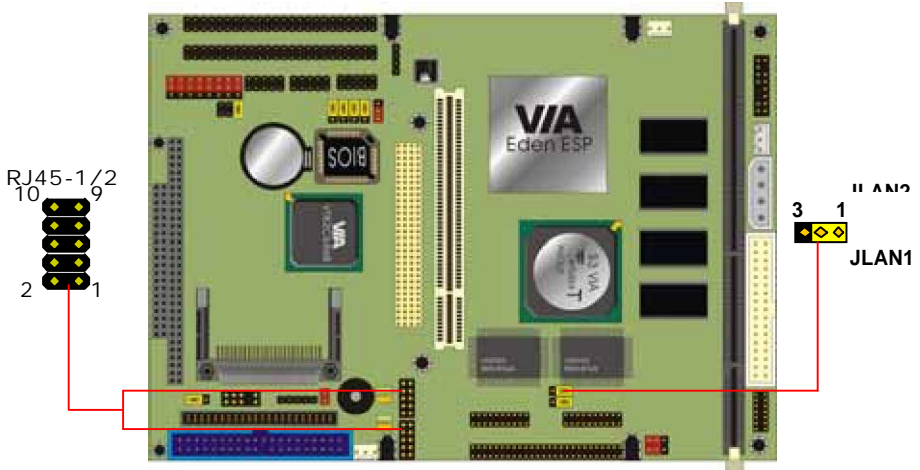

Connector: RJ45-1/2
Type: 10-pin header connector

Pin	Description	Pin	Description
1	TX+	2	TX-
3	RX+	4	N/C
5	N/C	6	RX-
7	N/C	8	N/C
9	Ground	10	Ground

Jumper: **JLAN1/2**
Type: onboard 3-pin (1 x 3) header

JLAN1/2	LAN Controller Switch
1-2	Enable
2-3	Disable

Default setting

2.9 Audio Interface

The board integrates with AC97 3D audio interface VIA 686B and Realtek ALC201A codec that provides line-in, line-out, Mic-in and CD-in interfaces for industrial applications with audio function.

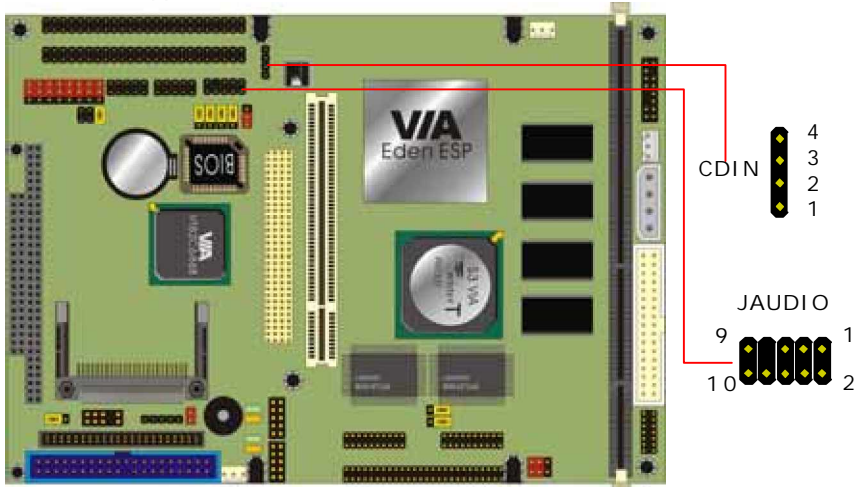

Connector: JAUDIO
Type: 10-pin header

Pin	Description	Pin	Description
1	Line – Right	2	Ground
3	Line – Left	4	MIC
5	MIC	6	Ground
7	N/C	8	Line Out – Left
9	Line Out – Right	10	Ground

Connector: CDIN
Type: 4-pin header

Pin	Description
1	CD – Left
2	Ground
3	Ground
4	CD – Right

2.10 Multiple I/O Port Configuration

The onboard COM2 RS-422/485 mode setting is done by the jumper JCSEL and JP18, and activates at pin 11 to 20 of connector JIO1.

2.10.1 COM2 RS-422/485 Mode Selection

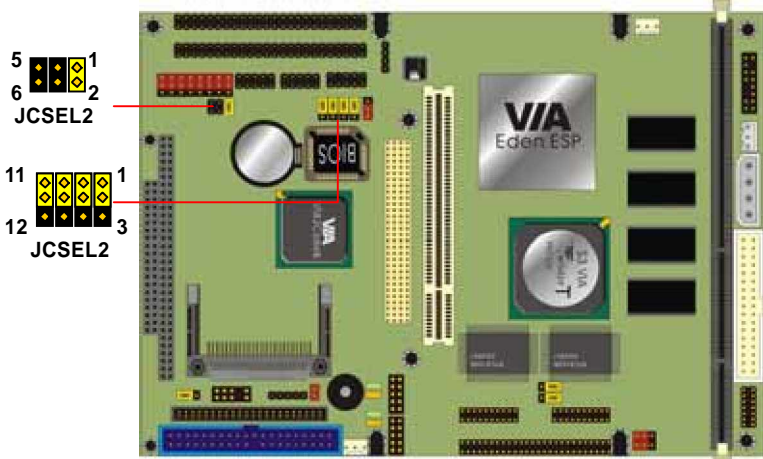

Jumper: JCSEL2, JCSEL1
 Type: onboard 6-, 12-pin header

COM2 Mode	JCSEL2	JCSEL1
RS-232	1-2	1-2/4-5/7-8/10-11
RS-422	5-6	2-3/5-6/8-9/11-12
RS-485	3-4	2-3/5-6/8-9/11-12

Default setting

Connector: Pin11~20 on JIO1
 Type: 10-pin header

Pin	RS232	RS422	RS485	Pin	RS232	RS422	RS485
11	DCD	TX-	485-	12	RXD	TX+	485+
13	TXD	RX+	N/C	14	DTR	RX-	N/C
15	Ground	N/C	N/C	16	DSR	N/C	N/C
17	RTS	N/C	N/C	18	CTS	N/C	N/C
19	RI	N/C	N/C	20	N/C	N/C	N/C

2.10.2 COM Port +5V/+12V Power Mode Selection

The board offers the +5V/+12V power pin on the onboard 4 serial ports. The power mode can be setting with jumper JCVOLT.

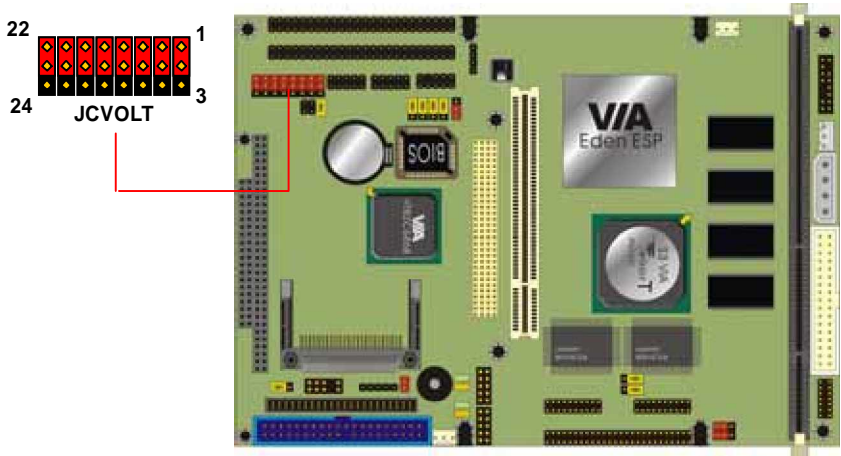

Jumper: JCVLOT
Type: onboard 24-pin header

Port	RS232	+5V	+12V
COM1	1-2/13-14	2-3	14-15
COM2	4-5/16-17	5-6	17-18
COM3	7-8/19-20	8-9	20-21
COM4	9-10/22-23	10-11	23-24

Default setting

2.11 Expansive Bus Interfaces

The board offers PCI/ISA expansive bus interfaces including one PCI slot and one PC/104-plus connector.

2.11.1 PCI Bus Interface

The onboard expansive PCI bus interface offers 2 sets of bus master PCI signal to support up to 2 pieces of PCI-based add-on cards via an additional riser card.

2.11.2 PC/104-plus Interface

The onboard PC/104-plus interface includes 32-bit PCI-based 120-pin PC/104-plus interface and 16-bit ISA-based PC/104 interface. There is one set of bus master PCI signal is supported on the onboard PC/104-plus interface. More information about PC/104-plus interface is available at: <http://www.pc104.org/>

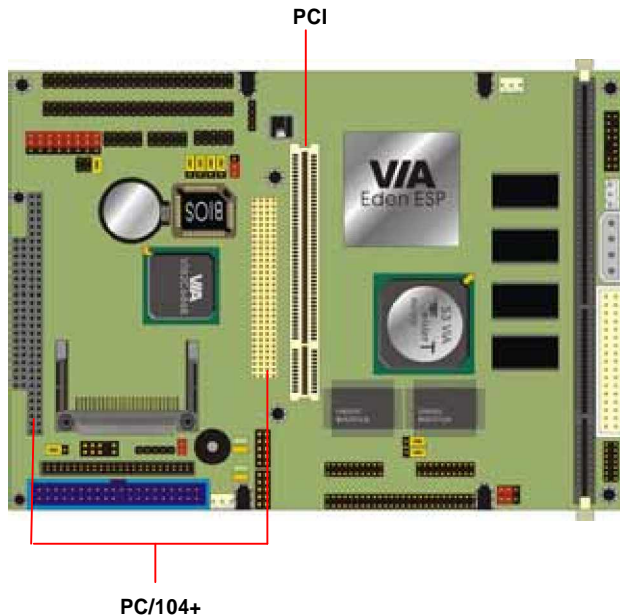

2.12 Switches and Indicators

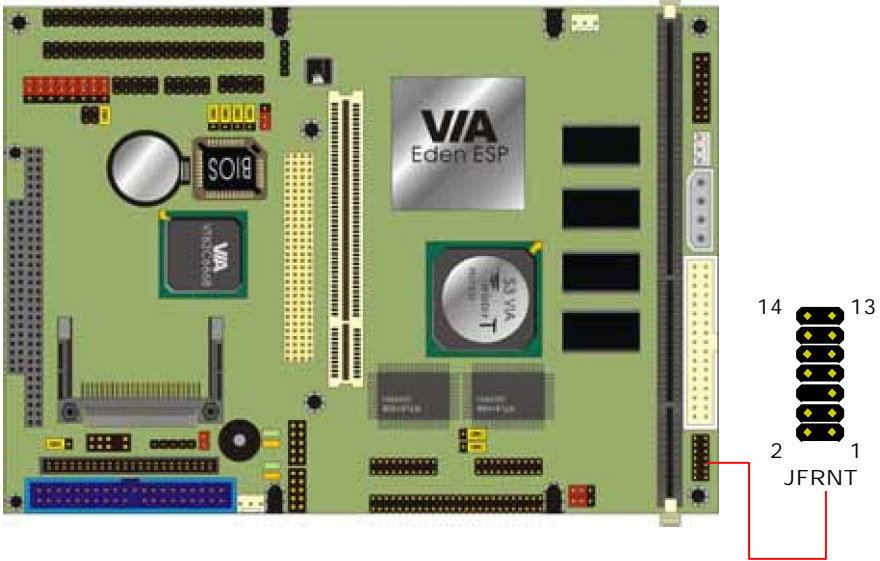

Connector: JFRNT

Type: onboard 14-pin header

Function	Signal	PIN		Signal	Function
IDE LED	Vcc (+)	1	2	(+) Vcc	Power LED
	Active	3	4	N/C	
Reset	Reset	5	6	GND	Speaker
	GND	7	8	Vcc	
N/C		9	10	N/C	
Power Button	PWRBT	11	12	N/C	
	GND	13	14	SPKIN	

Chapter 3. BIOS Setup

The single board computer uses the Award BIOS for the system configuration. The Award BIOS in the single board computer is a customized version of the industrial standard BIOS for IBM PC AT-compatible computers. It supports Intel x86 and compatible CPU architecture based processors and computers. The BIOS provides critical low-level support for the system central processing, memory and I/O sub-systems.

The BIOS setup program of the single board computer let the customers modify the basic configuration setting. The settings are stored in a dedicated battery-backed memory, NVRAM, retains the information when the power is turned off. If the battery runs out of the power, then the settings of BIOS will come back to the default setting. The BIOS section of the manual is subject to change without notice and is provided here for reference purpose only. The settings and configurations of the BIOS are current at the time of print, and therefore they may not be exactly the same as that displayed on your screen.

To activate CMOS Setup program, press key immediately after you turn on the system. The following message "Press DEL to enter SETUP" should appear in the lower left hand corner of your screen. When you enter the CMOS Setup Utility, the Main Menu will be displayed as **Figure 3-1**. You can use arrow keys to select your function, press <Enter> key to accept the selection and enter the sub-menu.

Figure 3-1. CMOS Setup Utility Main Screen

Phoenix – Award BIOS CMOS Setup Utility	
>Standard CMOS Features	>Frequency/Voltage Control
>Advanced BIOS Features	Load Fail-Safe Defaults
>Advanced Chipset Features	Load Optimized Defaults
>Integrated Peripherals	Set Supervisor Password
>Power Management Setup	Set User Password
>PnP / PCI Configurations	Save & Exit Setup
>PC Health Status	Exit Without Saving
Esc : Quit	: Select Item
F10 : Save & Exit Setup	

3.1 Flat Panel Type Setting

3.1.1 Advanced Chipset Features Screen

The selection of display type for flat panel depends on the LCD display you use. Please enter the “Advanced Chipset Features” screen on the main screen and find the item of “Panel Type”, and set it with the specification of the flat panel.

Figure 3.2 - Advanced Chipset Features Screen

Phoenix – AwardBIOS CMOS Setup Utility
Advanced Chipset Features

DRAM Timing	[By SPD]	Item Help
DRAM Clock	[By SPD]	Menu Level
SDRAM Cycle Length	3	
Bank Interleave	Disabled	
Memory Hole	Disabled	
P2C/C2P Concurrency	Enabled	
System BIOS Cacheable	Disabled	
Video RAM Cacheable	Disabled	
Frame Buffer Size	16M	
AGP Aperture Size	64M	
AGP-4X Mode	Enabled	
AGP Driving Control	: [Auto]	
AGP Driving Value	: DA	
Panel Type	07	
Boot Device Select	[Auto]	
Power-Supply Type	AT	
OnChip USB	Enabled	
USB Keyboard Support	Disabled	
USB Mouse Support	Disabled	
OnChip Sound	[Auto]	
OnChip Modem	Disabled	
CPU to PCI Write Buffer	: Enabled	
PCI Dynamic Bursting	: Disabled	
PCI Master 0 WS Write	: Disabled	
PCI Delay Transaction	: Disabled	
PCI#2 Access #1 Retry	: Disabled	
AGP Master 1 WS Write	: Disabled	
AGP Master 1 WS Read	: Disabled	

:Move Enter:Select +/-/PU/PD:Value F10:Save ESC:Exit F1:General Help
F5 : Previous Value F6 : Fail-Safe Defaults F7 : Optimized Defaults

3.1.2 Panel Type

The chipset / BIOS built-in flat panel selection offers the support of general flat panel. Please find the panel type you use on the list below, save and exit BIOS to restart the system.

Panel Type	Support Function
00	640x480 TFT
01	800x600 TFT
02	1024x768TFT 2pixel/clock at 32Mhz
03	1280x1024 TFT
04	640x480 DSTN
05	800x600 DSTN
06	1024x768 DSTN
07	1024x768 TFT 1pixel/clock at 65Mhz
08	640x480 TFT
09	800x600 TFT
0A	1024x768 TFT
0B	1280x1024 TFT
0C	1400x1050 TFT 2pixel/clock at 54Mhz
0D	800x600 DSTN
0E	1024x768 DSTN
0F	1280x1024 DSTN

Default Setting

Notes (This page left blank intentionally)

A large, empty rectangular box with a thin black border, occupying most of the page. It is intended for the user to write notes.

Chapter 4. Driver Installation

The driver CD offers auto-run menu. It will detect and select the type of single board computer and helps you install the drivers automatically.

4.1 Install Chipset Software

The selection helps you install the drivers of chipset. It will detect your version of OS automatically.

4.2 Install Ultra ATA IDE Driver

The selection helps you to install the driver of IDE interface.

4.3 Install VGA Driver

The selection helps you to install the driver of onboard VGA interface.

4.4 Install LAN Driver

The selection helps you to install the driver of onboard LAN interface.

4.5 Install Audio Driver

The selection helps you to install the driver of onboard audio interface.

4.6 Link to < Website > Homepage

The selection help you to link to the website to find the updated technical documents and download directly.

4.7 Manual

View 3302011 Manual in PDF format.

Notes (This page left blank intentionally)

A large, empty rectangular box with a thin black border, occupying most of the page. It is intended for the user to write notes.

Appendix A. I/O Port Pin Assignment

A.1 IDE Port

Connector: **IDE1**

Type: 40-pin (2 x 20) box header

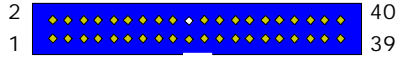

Pin	Description	Pin	Description
1	Reset	2	Ground
3	D7	4	D8
5	D6	6	D9
7	D5	8	D10
9	D4	10	D11
11	D3	12	D12
13	D2	14	D13
15	D1	16	D14
17	D0	18	D15
19	Ground	20	N/C (Vcc)
21	REQ	22	Ground
23	IOW-/STOP	24	Ground
25	IOR-/HDMARDY	26	Ground
27	IRDY/DDMARDY	28	IDESEL
29	DACK-	30	Ground
31	IRQ	32	N/C
33	A1	34	CBLID
35	A0	36	A2
37	CS0 (MASTER CS)	38	CS1 (SLAVE CS)
39	LED ACT-	40	Ground

Connector: **IDE2**

Type: 44-pin (2 x 22) box header



Pin	Description	Pin	Description
1	Reset	2	Ground
3	D7	4	D8
5	D6	6	D9
7	D5	8	D10
9	D4	10	D11
11	D3	12	D12
13	D2	14	D13
15	D1	16	D14
17	D0	18	D15
19	Ground	20	N/C
21	REQ	22	Ground
23	IOW-/STOP	24	Ground
25	IOR-/HDMARDY	26	Ground
27	IORDY/DDMARDY	28	Ground
29	DACK-	30	Ground
31	IRQ	32	N/C
33	A1	34	SD
35	A0	36	A2
37	CS1	38	CS3
39	ASP1	40	Ground
41	Vcc	42	Vcc
43	Ground	44	Ground

A.2 FDD Port

Connector: **FDD1**

Type: 34-pin (2 x 17) header

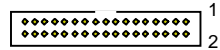

Pin	Description	Pin	Description
1	Ground	2	DRIVE DENSITY SELECT 0
3	Ground	4	DRIVE DENSITY SELECT 1
5	Ground	6	N/C
7	Ground	8	INDEX-
9	Ground	10	MOTOR ENABLE A-
11	Ground	12	DRIVER SELECT B-
13	Ground	14	DRIVER SELECT A-
15	Ground	16	MOTOR ENABLE B-
17	Ground	18	DIRECTION-
19	Ground	20	STEP-
21	Ground	22	WRITE DATA-
23	Ground	24	WRITE GATE-
25	Ground	26	TRACK 0-
27	Ground	28	WRITE PROTECT-
29	Ground	30	READ DATA-
31	Ground	32	HEAD SELECT-
33	Ground	34	DISK CHANGE-

A.3 Serial and Parallel Port

Connector: **J101, J102**

Type: Dual 50-pin (2 x 25) header



Pin	Signal	Pin	Signal
1	N/C	2	Ground
3	DCD1 (3)	4	RXD1 (3)
5	TXD1 (3)	6	DTR1 (3)
7	Ground	8	DSR1 (3)
9	RTS1 (3)	10	CTS1 (3)
11	RI1 (3)	12	N/C
13	DCD2 (4)	14	RXD2 (4)
15	TXD2 (4)	16	DTR2 (4)
17	Ground	18	DSR2 (4)
19	RTS2 (4)	20	CTS2 (4)
21	RI2 (4)	22	N/C
23	STROBE1 (2)	24	AUTO FEED1 (2)
25	D01 (2)	26	ERROR1 (2)
27	D11 (2)	28	INITIALIZE1 (2)
29	D21 (2)	30	SELECT INPUT1 (2)
31	D31 (2)	32	Ground
33	D41 (2)	34	Ground
35	D51 (2)	36	Ground
37	D61 (2)	38	Ground
39	D71 (2)	40	Ground
41	ACKNOWLEDGE1 (2)	42	Ground
43	BUSY1 (2)	44	Ground
45	PAPER EMPTY1 (2)	46	Ground
47	SELECT1 (2)	48	AUTO FEED1 (2)
49	Ground	50	Ground

A.4 USB Port

Connector: **JUSB1, JUSB2**

Type: 10-pin (2 x 5) header for dual USB Ports



Pin	Description	Pin	Description
1	Vcc	2	Vcc
3	Data1-	4	Data0-
5	Data1+	6	Data0+
7	Ground	8	Ground
9	Ground	10	Ground

A.5 IrDA Port

Connector: **JIR**

Type: 5-pin (1 x 5) header for SIR Port



Pin	Description
1	Vcc
2	N/C
3	IRRX
4	Ground
5	IRTX

A.6 PS/2 Keyboard and Mouse Port

Connector: **JPS2**

Type: 10-pin (2 x 5) header connector



Pin	Description	Pin	Description
1	Keyboard Data	2	Mouse Data
3	N/C	4	N/C
5	Ground	6	Ground
7	Ground	8	Ground
9	Keyboard Clock	10	Mouse Clock

Appendix B. Flash the BIOS

B.1 BIOS Auto Flash Tool

The board is based on Award BIOS and can be updated easily by the BIOS auto flash tool. You can download the tool online at the address below:

<http://www.award.com>

File name of the tool is “awdfash.exe”, it’s the utility that can write the data into the BIOS flash ship and update the BIOS.

B.2 Flash Method

1. Get the “.bin” file including the image of new BIOS you want to update.
2. Power on the system and flash the BIOS.
3. Re-star the system.

Appendix C. System Resources

C.1 I/O Port Address Map

Address Range	Device
0060-0060	i8042prt
0064-0064	i8042prt
0170-0170	viadsk
01CE-01CF	VgaSave
01F0-01F7	viadsk
0278-027A	Parport
02E8-02EE	Serial
02F8-02FE	Serial
0376-0376	viadsk
0378-037A	Parport
03B0-03BB	VgaSave
03C0-03CF	S3Inc
03C0-03DF	VgaSave
03D4-03DB	S3Inc
03E8-03EE	Serial
03F0-03F5	Floppy
03F6-03F6	viadsk
03F7-03F7	Floppy
03F8-03FE	Serial
D000-D007	viadsk
D008-D00F	viadsk
DC00-DCFF	alcxnt
E000-E003	alcxnt

C.2 Memory Address Map

Range	Device
x00000000 - x0009FFFF	System board extension for PnP BIOS
x000A0000 - x000AFFFF	S3 Graphics Twister
x000B0000 - x000BFFFF	S3 Graphics Twister
x000F0000 - x000F3FFF	Motherboard resources
x000F4000 - x000F7FFF	Motherboard resources
x000F8000 - x000FBFFF	Motherboard resources
x000FC000 - x000FFFF	Motherboard resources
x00100000 - x00FFFFFF	System board extension for PnP BIOS
xE0000000 - xE7FFFFFF	VIA CPU to AGP Controller
xE0000000 - xE7FFFFFF	S3 Graphics Twister
xE8000000 - xEBFFFFFF	VIA Standard CPU to PCI Bridge
xEC000000 - xEC07FFFF	S3 Graphics Twister
xEC000000 - xEC0FFFF	VIA CPU to AGP Controller
xEC080000 - xEC08FFFF	S3 Graphics Twister
xEC100000 - xEC1001FF	Realtek RTL8139(A/B/C/8130) PCI Fast Ethernet NIC
xEC101000 - xEC1011FF	Realtek RTL8139(A/B/C/8130) PCI Fast Ethernet NIC
xFEE00000 - xFEE0FFFF	System board extension for PnP BIOS
xFFFFE0000 - xFFFFFF	System board extension for PnP BIOS

C.3 System IRQ and DMA Resource

C.3.1 IRQ

IRQ Number	Device
0	System timer
1	Standard 101/102-Key or Microsoft Natural Keyboard
2	Programmable interrupt controller
3	Communications Port (COM2)
4	Communications Port (COM1)
5	Printer Port (LPT2)
6	Standard Floppy Disk Controller
7	Printer Port (LPT1)
8	System CMOS/real time clock
9	Realtek RTL8139(A/B/C/8130) PCI Fast Ethernet NIC
9	Realtek RTL8139(A/B/C/8130) PCI Fast Ethernet NIC
9	Avance AC'97 Audio for VIA (R) Audio Controller
9	VIA Tech 3038 PCI to USB Universal Host Controller
9	VIA Tech 3038 PCI to USB Universal Host Controller
9	S3 Graphics Twister
9	IRQ Holder for PCI Steering
9	IRQ Holder for PCI Steering
9	IRQ Holder for PCI Steering
10	Communications Port (COM3)
11	Communications Port (COM4)
12	PS/2 Compatible Mouse Port
13	Numeric data processor
14	Primary IDE controller (dual fifo)
14	VIA Bus Master PCI IDE Controller
15	Secondary IDE controller (dual fifo)
15	VIA Bus Master PCI IDE Controller

C.3.2 DMA

Channel	Device
0	(free)
1	(free)
2	Standard Floppy Disk Controller
3	(free)
4	Direct memory access controller
5	(free)
6	(free)
7	(free)

Notes (This page left blank intentionally)

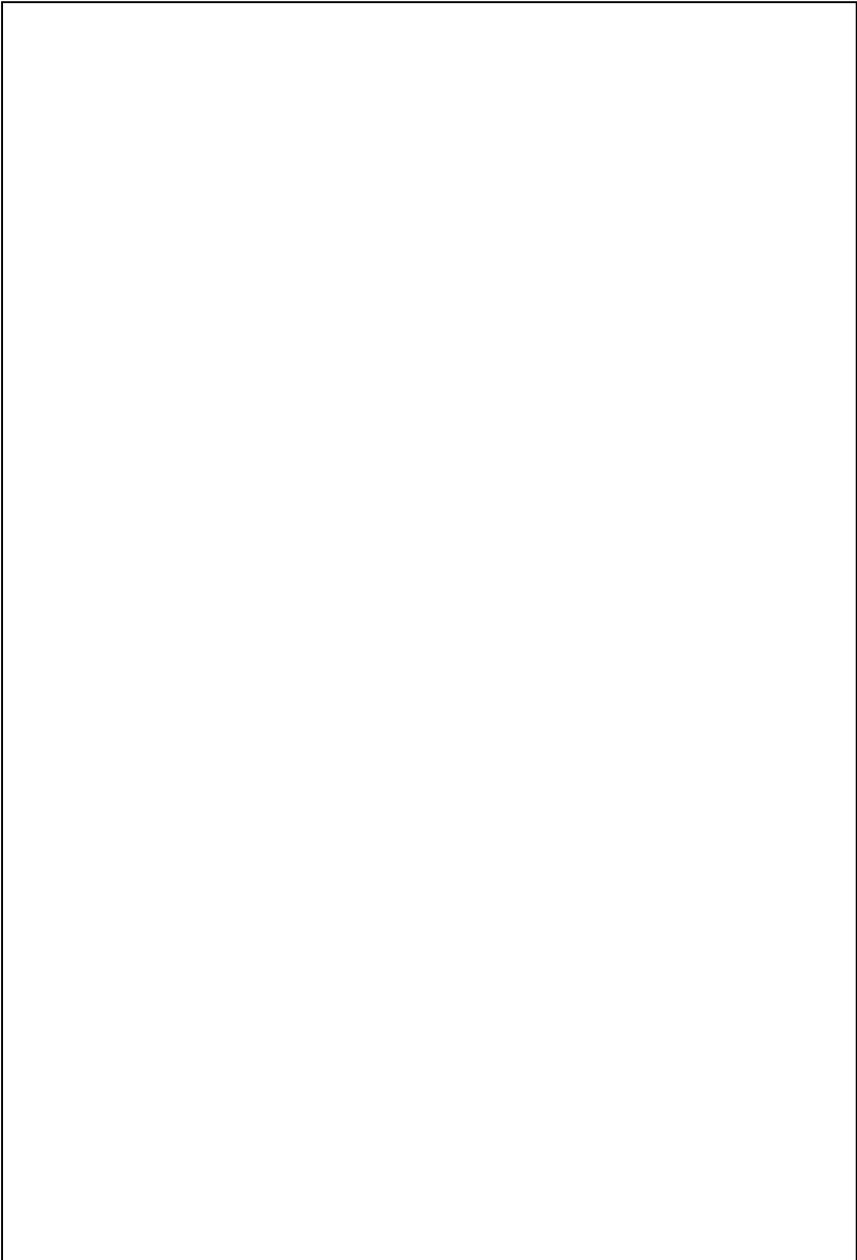

Contact Information



Thank you for purchasing from Global American Inc. We will stand by our slogan,
“Integration with Integrity”.

Please let us know how your product is performing and if we can help you with any future product lines.

Address	17 Hampshire Drive Hudson, NH 03051
TEL	(800) 833 8999
FAX	(603) 886 4545
Website	http://www.globalamericaninc.com
E-mail	salesinfo@globalamericaninc.com (Sales) support@globalamericaninc.com (Tech Support)
