



User's Manual

3302040

Version 1.0

Initial release: November 2006

Copyright

COPYRIGHT NOTICE

The information in this document is subject to change without prior notice in order to improve reliability, design and function and does not represent a commitment on the part of the manufacturer.

In no event will the manufacturer be liable for direct, indirect, special, incidental, or consequential damages arising out of the use or inability to use the product or documentation, even if advised of the possibility of such damages.

This document contains proprietary information protected by copyright. All rights are reserved. No part of this manual may be reproduced by any mechanical, electronic, or other means in any form without prior written permission of the manufacturer.

TRADEMARKS

IBM PC is a registered trademark of International Business Machines Corporation. INTEL is a registered trademark of INTEL Corporation. Other product names mentioned herein are used for identification purposes only and may be trademarks and/or registered trademarks of their respective owners.

Table of Contents

1	INTRODUCTION.....	1
1.1	3302040 OVERVIEW.....	2
1.1.1	<i>3302040 Models</i>	2
1.1.2	<i>3302040 Applications</i>	2
1.1.3	<i>3302040 Benefits</i>	2
1.1.4	<i>3302040 Features</i>	3
1.2	3302040 OVERVIEW.....	4
1.2.1	<i>3302040 Connectors</i>	5
1.2.2	<i>Technical Specifications</i>	7
2	DETAILED SPECIFICATIONS	9
2.1	OVERVIEW	10
2.2	BOARD DIMENSIONS	10
2.2.1	<i>Board Dimensions</i>	10
2.2.2	<i>External Interface Panel Dimensions</i>	11
2.2.3	<i>Embedded AMD[®] Geode[™] GX 466 Specifications</i>	11
2.3	SYSTEM CHIPSET	12
2.4	DATA FLOW	13
2.5	GRAPHICS SUPPORT	13
2.6	MEMORY SUPPORT	15
2.7	PCI BUS INTERFACE SUPPORT	15
2.8	ETHERNET CONTROLLER SPECIFICATIONS	15
2.8.1	<i>Overview</i>	15
2.8.2	<i>Features</i>	16
2.8.3	<i>SATA Drives</i>	16
2.8.4	<i>IDE HDD Interfaces</i>	17
2.8.5	<i>CompactFlash Support</i>	17
2.9	SERIAL PORTS	17
2.10	REAL TIME CLOCK.....	17
2.11	SYSTEM MONITORING.....	17
2.12	USB INTERFACES.....	18

2.13 BIOS	18
2.14 OPERATING TEMPERATURE AND TEMPERATURE CONTROL.....	18
2.15 AUDIO CODEC	18
2.16 POWER CONSUMPTION.....	20
2.17 PACKAGED CONTENTS AND OPTIONAL ACCESSORY ITEMS.....	20
2.17.1 <i>Package Contents</i>	20
2.17.2 <i>Optional Accessory Items</i>	21
3 CONNECTORS AND JUMPERS	23
3.1 PERIPHERAL INTERFACE CONNECTORS	24
3.1.1 <i>3302040 Layout</i>	24
3.1.2 <i>Peripheral Interface Connectors</i>	25
3.1.3 <i>External Peripheral Interface Connectors</i>	26
3.1.4 <i>Onboard Jumpers</i>	27
3.2 INTERNAL PERIPHERAL CONNECTORS.....	27
3.2.1 <i>AT Power Input Connector</i>	27
3.2.2 <i>ATX Power Connector</i>	28
3.2.3 <i>Audio Connector</i>	29
3.2.4 <i>CompactFlash Connector</i>	30
3.2.5 <i>Digital Input/Output (DIO) Connector</i>	32
3.2.6 <i>Fan Connector</i>	33
3.2.7 <i>IDE Connector</i>	34
3.2.8 <i>Inverter Power Connector</i>	36
3.2.9 <i>Keyboard and Mouse Connector</i>	37
3.2.10 <i>LED Connector</i>	38
3.2.11 <i>LCD LVDS Connector</i>	39
3.2.12 <i>LCD TTL Connector</i>	41
3.2.13 <i>Parallel Port Connector</i>	43
3.2.14 <i>PC/104 Slot</i>	45
3.2.15 <i>Power Switch Connector</i>	48
3.2.16 <i>Reset Button Connector</i>	49
3.2.17 <i>RS-232/422/485 Serial Port Connectors</i>	50
3.2.18 <i>SATA Drive Connectors</i>	51
3.2.19 <i>Suspend Power Input</i>	52
3.2.20 <i>Internal USB Connectors</i>	53

3.3 EXTERNAL INTERFACE CONNECTORS	54
3.3.1 External Interface Connector Overview	54
3.3.2 USB Combo Port.....	54
3.3.3 Ethernet Connector.....	55
3.3.4 Serial Communications COM 1 and COM2 Connector	56
3.3.5 VGA Connector	57
4 INSTALLATION AND CONFIGURATION	59
4.1 ANTI-STATIC PRECAUTIONS	60
4.2 INSTALLATION CONSIDERATIONS	60
4.2.1 Installation Notices	60
4.3 UNPACKING.....	61
4.3.1 Unpacking Precautions.....	61
4.3.2 Checklist.....	62
4.4 3302040 MOTHERBOARD INSTALLATION	62
4.4.1 DIMM Module Installation.....	63
4.4.1.1 Purchasing the Memory Module.....	63
4.4.1.2 DIMM Module Installation.....	63
4.5 JUMPER SETTINGS	64
4.5.1 Clear CMOS Jumper.....	65
4.5.2 AT Power Select Jumper Settings.....	67
4.5.3 RS-422/485 Serial Port Select	68
4.5.4 COM 1/2 Port RI and Voltage Select (OPTIONAL)	69
4.5.5 LCD Voltage Selection	70
4.5.6 CRT/LCD Mode Selection.....	71
4.6 CHASSIS INSTALLATION	72
4.6.1 Chassis selection.....	73
4.6.2 Install the CompactFlash card.....	73
4.6.3 Install the RS-232/422/485 Cable.....	74
4.6.4 IDE Disk Drive Connector.....	75
4.6.5 SATA Drive Connection	76
4.7 REAR PANEL CONNECTORS	77
4.7.1 LCD Panel Connection	77
4.7.2 Ethernet Connection	77
4.7.3 USB Connection.....	78

4.7.4 Keyboard and Mouse Connection.....	78
5 AWARD BIOS SETUP	79
5.1 INTRODUCTION	80
5.1.1 Starting Setup.....	80
5.1.2 Using Setup	80
5.1.3 Getting Help.....	81
5.1.4 Unable to Reboot After Configuration Changes.....	81
5.1.5 Main BIOS Menu	81
5.2 STANDARD CMOS FEATURES	84
5.2.1 IDE Primary Master/Slave	86
5.3 ADVANCED BIOS FEATURES	89
5.4 ADVANCED CHIPSET FEATURES	97
5.4.1 Flat Panel Configuration.....	100
5.5 INTEGRATED PERIPHERALS	103
5.5.1 IT8888 ISA Decode IO.....	110
5.5.2 IT8888 ISA Decode Memory.....	113
5.6 POWER MANAGEMENT SETUP.....	115
5.6.1 Power Management	118
5.7 PNP/PCI CONFIGURATIONS	120
5.8 PC HEALTH STATUS	125
6 SOFTWARE DRIVERS	127
6.1 AVAILABLE SOFTWARE DRIVERS	128
6.2 VGA DRIVER.....	130
6.3 AUDIO DRIVER INSTALLATION	139
6.4 LAN DRIVER	144
6.5 SATA/RAID DRIVER.....	148
6.6 ISA DRIVER	153
A BIOS OPTIONS	161
B DIO CONNECTOR	167
B.1 DIO INTERFACE INTRODUCTION	168
B.2 DIO CONNECTOR PINOUTS	168
B.3 ASSEMBLY LANGUAGE SAMPLES.....	169

<i>B.3.1 Enable the DIO Input Function</i>	169
<i>B.3.2 Enable the DIO Output Function</i>	169
C WATCHDOG TIMER	171
D ADDRESS MAPPING	175
D.1 ADDRESS MAP	176
D.2 1ST MB MEMORY ADDRESS MAP	176
D.3 IRQ MAPPING TABLE.....	177
D.4 DMA CHANNEL ASSIGNMENTS.....	177
E EXTERNAL AC'97 AUDIO CODEC	179
E.1 INTRODUCTION	180
<i>E.1.1 Accessing the AC'97 CODEC</i>	180
<i>E.1.2 Driver Installation</i>	180
E.2 SOUND EFFECT CONFIGURATION	181
<i>E.2.1 Accessing the Sound Effects Manager</i>	181
<i>E.2.2 Sound Effect Manager Configuration Options</i>	182
F ALI RAID	185
F.1 INTRODUCTION	186
<i>F.1.1 Precautions</i>	186
F.2 FEATURES AND BENEFITS	187
F.3 ACCESSING THE ALI RAID UTILITY	187
F.4 RAID OPTIONS:	189
<i>F.4.1 Create RAID 0 Striping for Performance</i>	189
<i>F.4.2 Create RAID 1 Mirroring for Reliability</i>	191
<i>F.4.3 Create JBOD for Integrated Capacity</i>	192
<i>F.4.4 Stripe Size</i>	194
<i>F.4.5 Delete RAID Setting & Partition</i>	194
<i>F.4.6 Delete All RAID Setting & Partition</i>	194
<i>F.4.7 Rebuild RAID Array</i>	195
<i>F.4.8 Select Boot Drive</i>	195
INDEX	197

List of Figures

Figure 1-1: 3302040 Overview	4
Figure 1-2: 3302040 Solder Side Overview	5
Figure 2-1: 3302040 Dimensions (mm).....	10
Figure 2-2: External Interface Panel Dimensions (mm).....	11
Figure 2-3: Data Flow Block Diagram.....	13
Figure 3-1: Connector and Jumper Locations	24
Figure 3-3: Connector and Jumper Locations (Solder Side).....	25
Figure 3-4: AT Power Connector Location	28
Figure 3-5: ATX Power Connector Location.....	29
Figure 3-6: Audio Connector Location.....	30
Figure 3-7: CompactFlash Connector Location.....	31
Figure 3-8: DIO Connector Connector Locations	33
Figure 3-9: Fan Connector Location	34
Figure 3-10: Primary IDE Device Connector Locations.....	35
Figure 3-11: Inverter Connector Location	36
Figure 3-12: Keyboard Connector Location	37
Figure 3-13: LED Connector Location.....	38
Figure 3-14: LCD LVDS Connector Locations.....	40
Figure 3-15: LCD TTL Connector Pinout Locations	42
Figure 3-16: Parallel Port Connector Location.....	44
Figure 3-17: PC/104 Slot Location	46
Figure 3-18: Power Switch Connector Locations	48
Figure 3-19: Reset Button Connector Locations	49
Figure 3-20: RS-232 Serial Port Connector Locations	50
Figure 3-21: SATA Drive Connector Locations.....	51
Figure 3-22: Suspend Power Connector Location.....	52
Figure 3-23: USB Connector Pinout Locations.....	53

Figure 3-24: 3302040 On-board External Interface Connectors	54
Figure 3-25: J7 Connector	56
Figure 3-26: COM1 Pinout Locations	57
Figure 3-27: VGA1 Connector	58
Figure 4-1: SO-DIMM Module Installation	64
Figure 4-2: Clear CMOS Connector	66
Figure 4-3: AT/ATX Mode Select Jumper.....	67
Figure 4-4: Serial Port Mode Select Jumper Pinout Locations	68
Figure 4-5: COM 1/2 Port RI and Voltage Select Jumper Pinout Locations	70
Figure 4-6: LVDS Voltage Selection Jumper Pinout Locations.....	71
Figure 4-7: CRT/LCD Mode Selection Jumper Settings	72
Figure 4-8: CompactFlash Card Installation.....	74
Figure 4-9: IDE Cable Connection	75
Figure 4-10: SATA Drive Cable Connection	76
Figure 4-11: SATA Drive Connection	77
Figure 6-1: AMD LX/GX CD Main Menu.....	129
Figure 6-2: AMD LX/GX CD Driver Menu.....	130
Figure 6-3: Access Windows Control Panel.....	131
Figure 6-4: Double Click the System Icon	132
Figure 6-5: Double Click the Device Manager Tab.....	132
Figure 6-6: Device Manager List.....	133
Figure 6-7: Expand the Display Adapters Category	134
Figure 6-8: Update Driver	135
Figure 6-9: Upgrade Device Driver Wizard	136
Figure 6-10: Search for Suitable Driver.....	137
Figure 6-11: Locate Driver Files.....	138
Figure 6-12: Location Browsing Window.....	138
Figure 6-13: Access Windows Control Panel.....	139
Figure 6-14: Double Click the System Icon	140
Figure 6-15: Double Click the Device Manager Tab.....	140
Figure 6-16: Device Manager List.....	141
Figure 6-17: Search for Suitable Driver.....	142

Figure 6-18: Locate Driver Files.....	143
Figure 6-19: Location Browsing Window.....	144
Figure 6-20: Locate the Setup Program Icon	145
Figure 6-21: Preparing Setup Screen	145
Figure 6-22: Install Wizard Welcome Screen.....	146
Figure 6-23: Installing Screen	147
Figure 6-24: Restart the Computer	148
Figure 6-25: Locate the Setup Program Icon	149
Figure 6-26: Preparing Setup Screen.....	149
Figure 6-27: Install Wizard Welcome Screen.....	150
Figure 6-28: Installing Screen	151
Figure 6-29: RAID Driver Digital Signal.....	152
Figure 6-30: InstallShield Wizard Complete Screen	153
Figure 6-31: Access Windows Control Panel.....	154
Figure 6-32: Double Click the System Icon	155
Figure 6-33: Double Click the Device Manager Tab.....	156
Figure 6-34: Device Manager List.....	157
Figure 6-35: Search for Suitable Driver.....	158
Figure 6-36: Locate Driver Files.....	159
Figure 6-37: Location Browsing Window.....	160

List of Tables

Table 1-1: 3302040 Model Specifications	2
Table 1-2: Technical Specifications	8
Table 2-1: Geode GX Graphics Features	15
Table 2-2: Power Consumption	20
Table 3-1: Onboard Peripheral Connectors.....	26
Table 3-2: Rear Panel Connectors.....	27
Table 3-3: Onboard Jumpers	27
Table 3-4: AT Power Connector Pinouts	28
Table 3-5: ATX Power Connector Pinouts	29
Table 3-6: Audio Connector Pinouts	30
Table 3-7: CompactFlash Connector Pinouts	32
Table 3-8: DIO Connector Connector Pinouts.....	33
Table 3-9: Fan Connector Pinouts.....	34
Table 3-10: Primary IDE Connector Pinouts.....	36
Table 3-11: Inverter Power Connector Pinouts	37
Table 3-12: Keyboard Connector Pinouts	38
Table 3-13: LED Connector Pinouts	39
Table 3-14: LCD LVDS Connector Pinouts	41
Table 3-15: TFT LCD TTL Port Connector Pinouts	43
Table 3-16: Parallel Port Connector Pinouts	44
Table 3-17: PC/104 Slot Connector Pinouts	48
Table 3-18: Power Switch Connector Pinouts.....	49
Table 3-19: Reset Button Connector Pinouts.....	50
Table 3-20: RS-232/422/485 Serial Port Connector Pinouts.....	51
Table 3-21: SATA Drive Connector Pinouts	52
Table 3-22: Suspend Power Connector Pinouts	53
Table 3-23: USB Port Connector Pinouts	54

Table 3-24: J6 Connector Pinouts	55
Table 3-25: J7 Connector Pinouts	55
Table 3-26: J7 Connector LEDs	56
Table 3-27: COM1 Pinouts.....	57
Table 3-28: VGA1 Connector Pinouts	58
Table 4-1: Jumpers	65
Table 4-2: Clear CMOS Jumper Settings	66
Table 4-3: AT Power Select Jumper Settings.....	67
Table 4-4: Serial Port Mode Select Jumper Settings.....	68
Table 4-5: COM 1/2 Port RI and Voltage Select Jumper Settings.....	69
Table 4-6: LVDS Voltage Selection Jumper Settings	71
Table 4-7: CRT/LCD Mode Selection Jumper Settings.....	72
Table 4-8: Global American, Inc Provided Cables.....	73
Table 5-1: BIOS Navigation Keys.....	81

BIOS Menus

BIOS Menu 1: Award BIOS CMOS Setup Utility	82
BIOS Menu 2: Standard CMOS Features	84
BIOS Menu 3: IDE Channel Master	87
BIOS Menu 4: Advanced BIOS Features.....	90
BIOS Menu 5: Advanced Chipset Features	98
BIOS Menu 6: Flat Panel Configuration	100
BIOS Menu 7: Integrated Peripherals.....	103
BIOS Menu 8: IT8888 ISA Decode IO.....	111
BIOS Menu 9: IT8888 ISA Decode Memory.....	114
BIOS Menu 10: Power Management Setup.....	116
BIOS Menu 11: IRQ Wakeup Events.....	119
BIOS Menu 12: PnP/PCI Configurations	120
BIOS Menu 13: IRQ Resources	122
BIOS Menu 14: Memory Resources.....	123
BIOS Menu 15: PC Health Status.....	125

Glossary

AC '97	Audio Codec 97	IDE	Integrated Data Electronics
ACPI	Advanced Configuration and Power Interface	I/O	Input/Output
APM	Advanced Power Management	ICH4	I/O Controller Hub 4
ARMD	ATAPI Removable Media Device	L1 Cache	Level 1 Cache
ASKIR	Shift Keyed Infrared	L2 Cache	Level 2 Cache
ATA	Advanced Technology Attachments	LCD	Liquid Crystal Display
BIOS	Basic Input/Output System	LPT	Parallel Port Connector
CFII	Compact Flash Type 2	LVDS	Low Voltage Differential Signaling
CMOS	Complementary Metal Oxide Semiconductor	MAC	Media Access Controller
CPU	Central Processing Unit	OS	Operating System
Codec	Compressor/Decompressor	PCI	Peripheral Connect Interface
COM	Serial Port	PIO	Programmed Input Output
DAC	Digital to Analog Converter	PnP	Plug and Play
DDR	Double Data Rate	POST	Power On Self Test
DIMM	Dual Inline Memory Module	RAM	Random Access Memory
DIO	Digital Input/Output	SATA	Serial ATA
DMA	Direct Memory Access	S.M.A.R.T	Self Monitoring Analysis and Reporting Technology
EIDE	Enhanced IDE	SPD	Serial Presence Detect
EIST	Enhanced Intel SpeedStep Technology	S/PDI	Sony/Philips Digital Interface
FFIO	Flexible File Input/Output	SDRAM	Synchronous Dynamic Random Access Memory
FIFO	First In/First Out	SIR	Serial Infrared
FSB	Front Side Bus	UART	Universal Asynchronous Receiver-transmitter
IrDA	Infrared Data Association	USB	Universal Serial Bus
HDD	Hard Disk Drive	VGA	Video Graphics Adapter

Chapter

1

Introduction

1.1 3302040 Overview

The 3.5" 3302040 AMD Geode GX 466 low power single board computer (SBC) is fully equipped with advanced multi-mode I/Os. The 3302040 is designed for system manufacturers, integrators, and VARs that want performance, reliability, and quality at a reasonable price.

1.1.1 3302040 Models

The 3302040 series has two models:

- „ 3302040A
- „ 3302040B

The specifications for the two models are show in **Table 1-1**.

3302040	A	B
CRT/LCD	YES	YES
Dual LAN	YES	YES
USB 2.0	YES	YES
SATA Drives	NO	YES
Audio	YES	YES

Table 1-1: 3302040 Model Specifications

1.1.2 3302040 Applications

The 3302040 is designed for applications in the following areas:

- „ Kiosks and Point of Sales
- „ Restaurants
- „ Human Machine Interface (HMI) applications
- „ Marine, GPS and transportation applications
- „ Financial, retail and kiosk applications

1.1.3 3302040 Benefits

Some of the 3302040 benefits include:

3302040

- „ Reduced hardware costs
- „ Reduced software costs
- „ Reduced maintenance costs
- „ Client crash prevention
- „ Central resource control
- „ Security protection

1.1.4 3302040 Features

Some of the 3302040 features are listed below:

- „ 3.5" form factor
- „ RoHS compliant
- „ Embedded AMD Geode GX 466 processor
- „ PC/104 expansion slot
- „ Dual-independent display functionality
- „ Two high performance 10/100 megabit Ethernet controllers on-board
- „ Two SATA channels with transfer rates up to 150MB/s on-board
(3302040B only)
- „ Four USB 2.0 devices supported
- „ Integrated audio

1.2 3302040 Overview

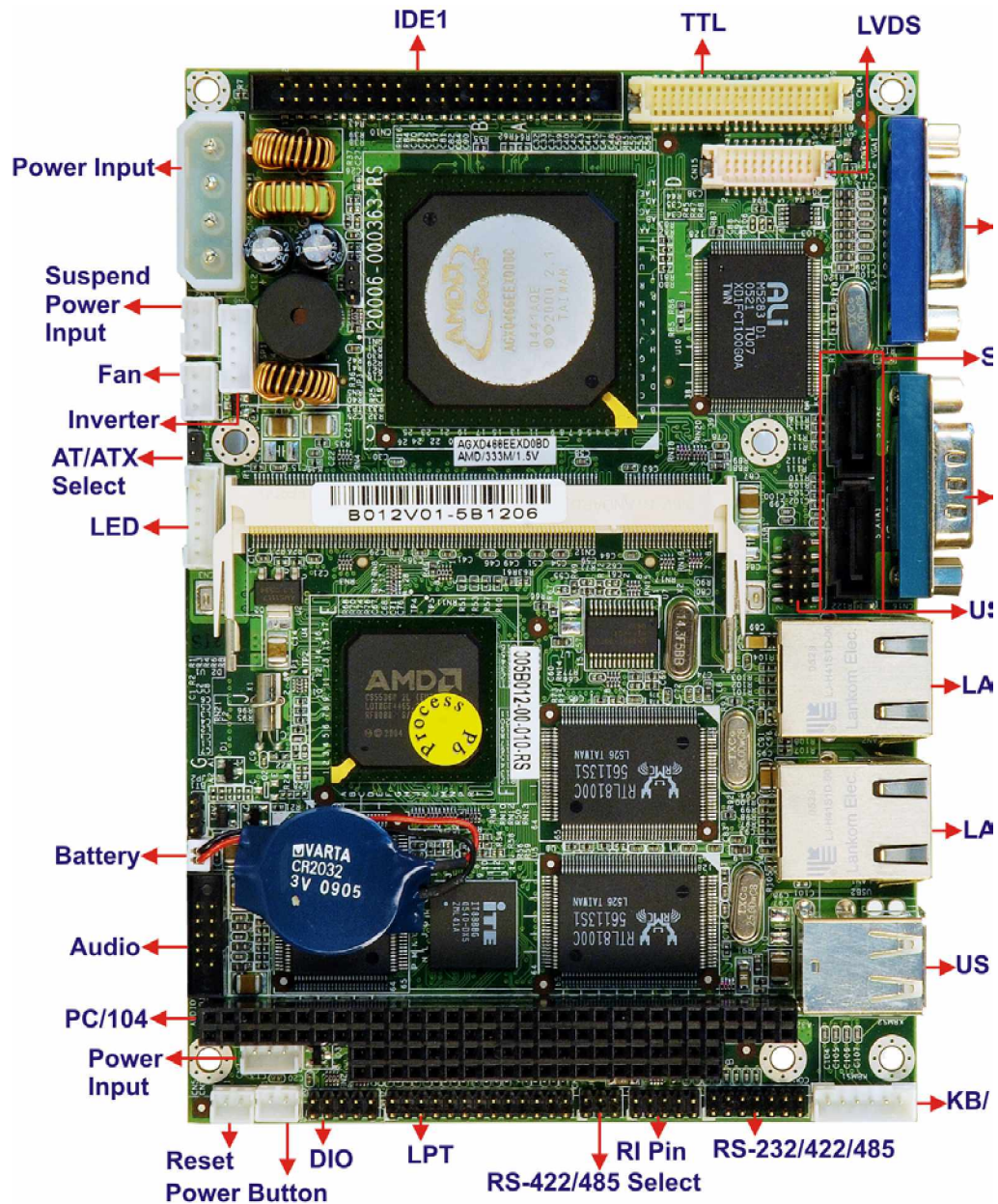

Figure 1-1: 3302040 Overview

3302040

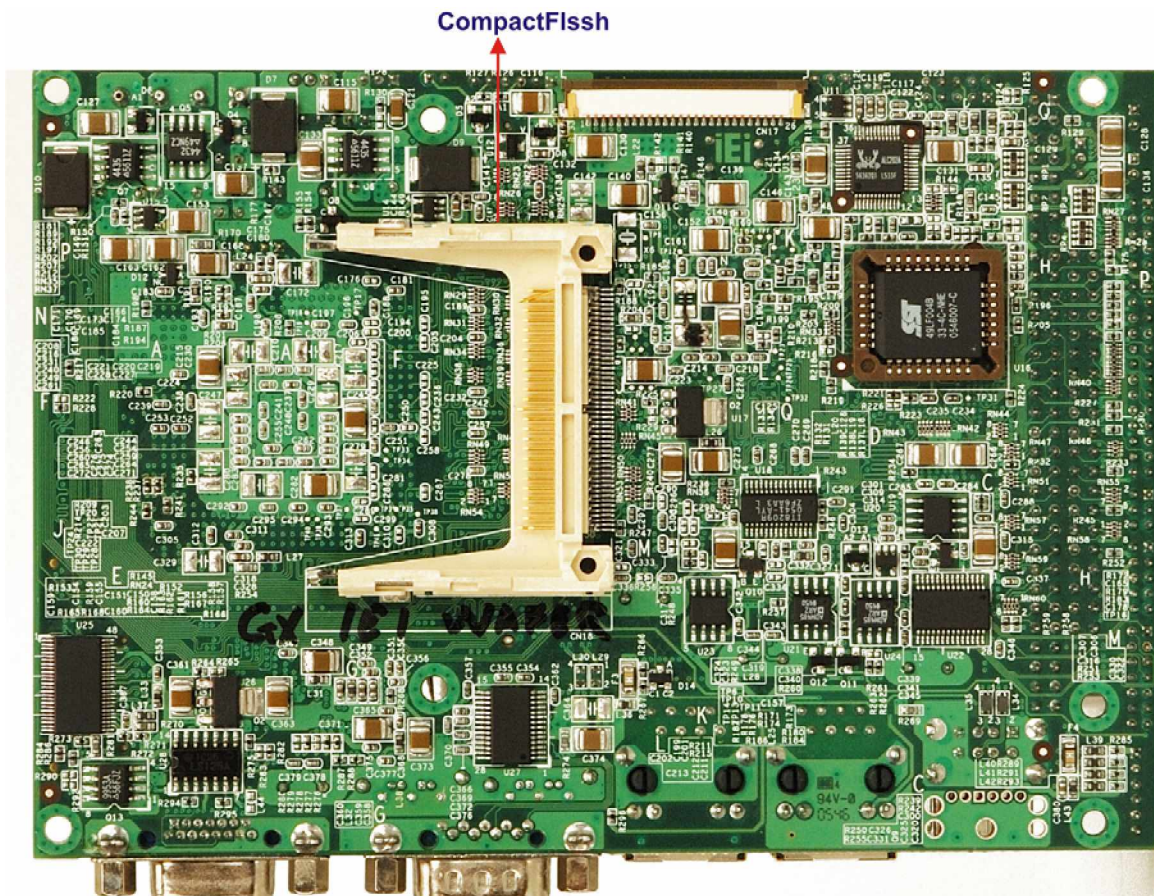

Figure 1-2: 3302040 Solder Side Overview

1.2.1 3302040 Connectors

The 3302040 has the following connectors onboard:

- „ 1 x AT power input connector
- „ 1 x ATX power input connector
- „ 1 x Audio connector
- „ 1 x Battery connector
- „ 1 x CompactFlash (CF) connector (solder side)
- „ 1 x Digital I/O (DIO) connector
- „ 1 x Fan connector
- „ 1 x IDE interface connectors (44-pin)
- „ 1 x Inverter power connector

- „ 1 x Keyboard/mouse connector
- „ 1 x LED connector
- „ 1 x LVDS LCD panel connector
- „ 1 x Parallel port connector
- „ 1 x Power button connector
- „ 1 x PC/104 slot
- „ 1 x Reset button connector
- „ 1 x RS-232/422/485 serial port connector
- „ 2 x SATA connectors
- „ 1 x Suspend power input connector
- „ 1 x TFT interface connector
- „ 1 x USB connector
- „ 1 x SO-DIMM socket

The 3302040 has the following connectors on the board rear panel:

- „ 2 x Ethernet connectors
- „ 1 x PS/2 Keyboard/mouse connector
- „ 1 x USB connector
- „ 1 x VGA connector

The 3302040 has the following onboard jumpers:

- „ AT/ATX power mode select
- „ COM1/2 Port RI and voltage selection
- „ RS-422/485 select
- „ LCD panel voltage select

1.2.2 Technical Specifications

3302040 technical specifications are listed in **Table 1-2**. Detailed descriptions of each specification can be found in **Chapter 2 Detailed Specifications**.

Specification	3302040
Form Factor	3.5" motherboard
CPU	AMD® Geode™ GX 466
Front Side Bus (FSB)	333MHz
System Chipset	AMD® Geode™ CS5536
Display	CRT integrated in the AMD® Geode™ GX 466
Memory	Supports one 200-pin, 266MHz, 512MB DDR SO-DIMM
BIOS	Award BIOS Label
SSD	CompactFlash (CF)
Super I/O	W83627EHG
Audio	Realtek ALC203 AC'97 Codec
LAN	Dual RTL8100C
COM	One RS-232 serial connector, one RS-232/422/485 serial connector
USB2.0	Four USB 2.0 devices supported by two onboard USB 2.0 connectors and two external USB 2.0 port
IDE	One 44-pin IDE connects to two Ultra ATA33/66/100 devices
Parallel Port	One LPT port connector
SATA	Two 150Mb/s SATA connectors
KB/MS	One PS/2 connector and one onboard connector

WDT	Software programmable 1-255 sec. by super I/O
Digital I/O	8-bit digital I/O with 4 input and 4 output
Fan connector	One 3-pin for CPU Fan
Expansion	One PC/104 expansion slot
Power	+5V AT/ATX support
Temperature	0°C - 60°C
Humidity	5%~95% non-condensing
Dimensions	146mm x102mm
Weight (GW/NW)	670g/230g

Table 1-2: Technical Specifications

Chapter

2

Detailed Specifications

2.1 Overview

This chapter describes the specifications and onboard features of the 3302040 in detail.

2.2 Board Dimensions

2.2.1 Board Dimensions

The dimensions of the board are listed below:

- **Length:** 146.06mm
- **Width:** 102mm

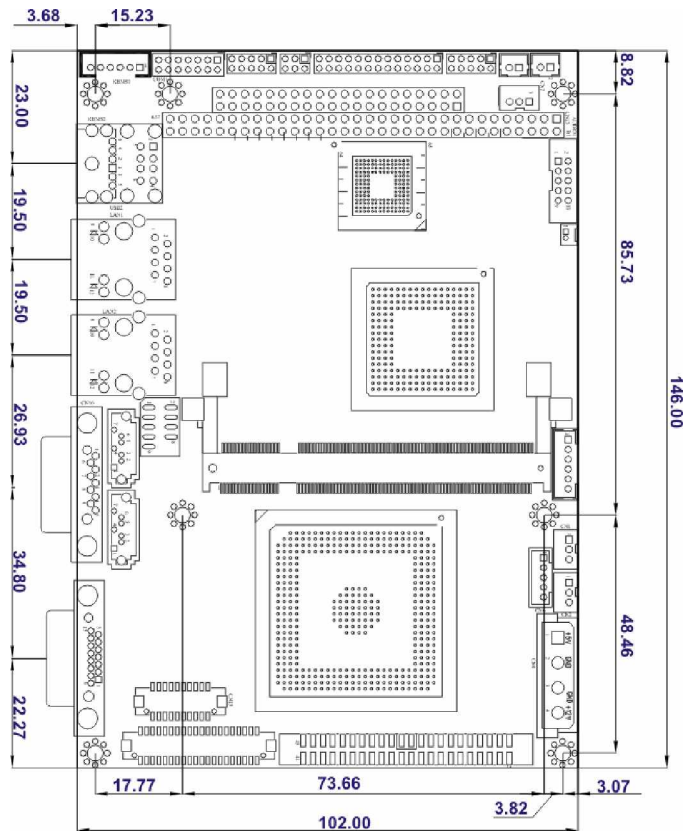

Figure 2-1: 3302040 Dimensions (mm)

2.2.2 External Interface Panel Dimensions

External interface panel dimensions are shown in **Figure 2-2**.

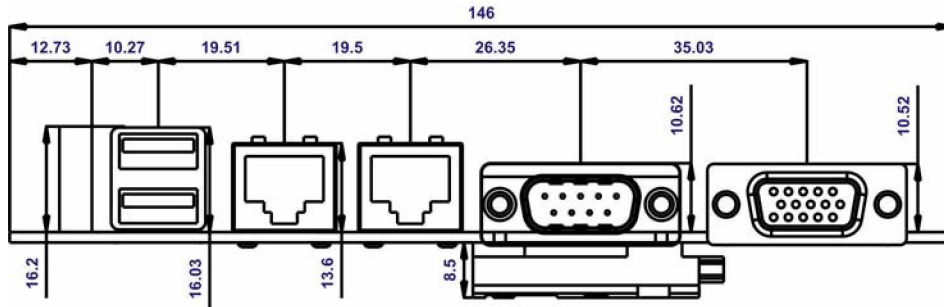

Figure 2-2: External Interface Panel Dimensions (mm)

The 3302040 series motherboards all come with a preinstalled AMD Geode™ GX 466 333Mhz CPU.

2.2.3 Embedded AMD® Geode™ GX 466 Specifications

The specifications for the 333Mhz AMD® Geode™ AMD GX 466 are listed below

- CPU Core
- GeodeLink™ Control Processor
- GeodeLink Interface Units
- GeodeLink Memory Controller
- Graphics Processor
- Display Controller
- Video Processor
- TFT Controller
- GeodeLink PCI Bridge
- Geode I/O Companion Device Interface
- 3.3W max @ 333 MHz
- Block level clock gating
- Active hardware power management
- Software power management

- Lower power I/O
- GeodeLink™ Interface Unit

2.3 System Chipset

The 3302040 series motherboards all have a preinstalled AMD® Geode™ CS5536 system chipset. The system chipset features are listed below.

- **GeodeLink™ Interface Unit**
 - 64-bit, 66MHz operation
 - PCI VSM (Virtual System Module) that makes the interface transparent to applications software and BIOS
 - Programmable routing descriptors, use and activity monitors, and SSMI (Synchronous System Management Interrupt)
- **ATA-6 Controller**
 - 100 MB/second IDE Controller in UDMA mode per the ATA-6 specification
 - 5V interface
- **Flash Interface**
 - Multiplexed with IDE interface Connects to an array of industry standard NAND Flash and/or NOR Flash
- **USB Controller**
 - 4 USB ports
 - Supports both USB 1.1 and USB 2.0
 - 3 host ports
 - 1 host/device
- **Audio Codec 97 (AC97) Controller**
 - AC97 specification v2.3 compliant interface to multiple audio codecs: Serial In, Serial Out, Sync Out, Bit Clock In
 - Legacy “PC Beep” support
- **Diverse Device**
 - 82xx Legacy Devices
 - IR Communication Port
 - System Management Bus (SMB) Controller
 - LPC (Low Pin Count) Port

- General Purpose I/Os (GPIOs)
- 8 Multi-Function General Purpose Timers (MFGPTs)
- Real-Time Clock (RTC) with CMOS RAM
- Power Management Controller
- ACPI v2.0 compliant

2.4 Data Flow

Figure 2-3 shows the data flow between the two onboard chipsets and other components installed on the motherboard and described in the following sections of this chapter.

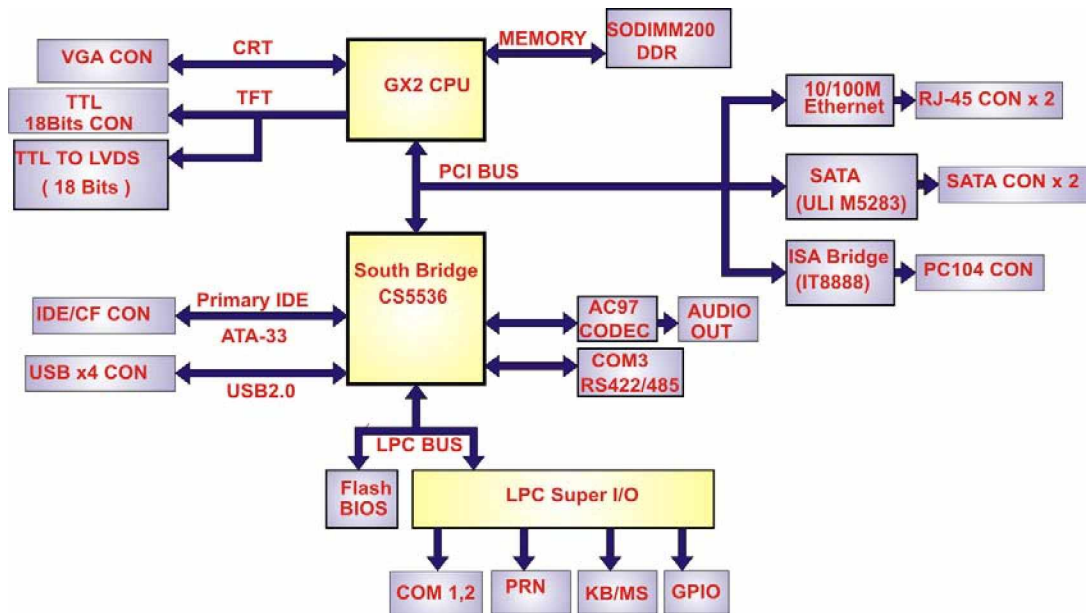

Figure 2-3: Data Flow Block Diagram

2.5 Graphics Support

The Graphics Processor is compatible with the graphics processor used in the GX1 processor with additional functions and features to improve performance and ease of use. Like its predecessor, the Geode GX processor's Graphics Processor is a BitBLT/vector engine that supports pattern generation, source expansion, pattern/source transparency, and 256 ternary raster operations. New features that have been added to the Graphics Processor include:

- „ Incorporated BLT FIFOs to replace the cache based BLT buffers used in the GX1 processor.
- „ Improved bus protocols to increase bandwidth to the memory controller.
- „ The ability to throttle BLTs according to video timing and VGA hardware. **Table**

2-1: Geode GX Graphics Features lists a complete list of Geode GX graphics features. For more details, please refer to the AMD website or the Geode GX series data book available from AMD.

Feature	AMD Geode™ GX Processor
Color Depth	32 bpp(24 plus 8 alpha blending)
ROPs	256 bpp
BLT Buffers	FIFOs in Graphics Processor
BLT Splitting	Managed by hardware
Video Synchronized BLT/Vector	Throttle by VBLANK
Bresenham Lines	Yes
Patterned (stippled) Lines	Yes
Screen to Screen BLT	Yes
Screen to Screen BLT with mono expansion	Yes
Memory to Screen BLT	Yes (through CPU writes)
Accelerated Text	No
Pattern Size (Mono)	8x8 pixels
Pattern Size (Color)	8x1 (32 pixels), 8x2 (16 pixels), 8x4 (8 pixels)
Monochrome Pattern	Yes
Dithered Pattern (4 color)	No
Color Pattern	8, 16, 32 bpp
Transparent Pattern	Monochrome
Solid Fill	Yes
Pattern Fill	Yes
Transparent Source	Monochrome
Color Key Source Transparency	Y with mask
Variable Source Stride	Yes
Variable Destination Stride	Yes

3302040

Destination Write Bursting	Yes
Selectable BLT Direction	Vertical and Horizontal
Alpha BLT	Yes (constant α , α/pix , or sep. α channel)
VGA Support	Decodes VGA Register

Table 2-1: Geode GX Graphics Features

2.6 Memory Support

The 3302040 CPU has one 200-pin DDR SO-DIMM socket with the following specifications:

- „ **Maximum RAM:** 512MB
- „ **DIMM Transfer Rates:** 266MHz

2.7 PCI Bus Interface Support

The PCI bridge on the 3302040 has the following features:

- „ 33MHz Revision 2.2 is implemented
- „ Maximum throughput: 133MB/sec
- „ PCI and GLIU interface control
- „ Read and write FIFOs
- „ PCI

2.8 Ethernet Controller Specifications

2.8.1 Overview

The Realtek RTL8100C(L) is a highly integrated and cost-effective single-chip Fast Ethernet controller. It is enhanced with an ACPI (Advanced Configuration Power Interface) management function for PCI in order to provide efficient power management for advanced operating systems with OSPM (Operating System Directed Power Management).

The RTL8100C(L) also supports remote wake-up (including AMD Magic Packet™ and Microsoft® Wake-up frame) to increase cost-efficiency in network maintenance and

management. It is an ideal solution for notebook/motherboard-embedded network designs.

2.8.2 Features

- „ Integrates Fast Ethernet MAC, physical chip, and transceiver onto a single chip
- „ 10Mbps and 100Mbps operation
- „ Supports 10Mbps and 100Mbps N-way auto-negotiation
- „ Supports 25MHz Crystal or 25MHz OSC as the internal clock source
- „ Complies with PC99/PC2001 standards
- „ Supports ACPI power management
- „ Provides PCI bus master data transfer
- „ Provides PCI memory space or I/O space mapped data transfer
- „ Supports PCI clock speed of 16.75MHz-40MHz
- „ Advanced power saving mode
- „ Supports Wake-on-LAN and remote wake-up (AMD Magic Packet™, Link Change, and Microsoft® Wake-up frame)
- „ Half/Full duplex capability
- „ Supports Full Duplex Flow Control (IEEE 802.3x)
- „ Provides interface to 93C46 EEPROM to store resource configuration and ID parameters
- „ Provides PCI clock run pin
- „ Provides LED pins for network operation status indication
- „ 2.5/3.3V power supply with 5V tolerant I/Os

The 3302040 can support the following drive interfaces.

- „ 2 x SATA drives
- „ 2 x IDE devices
- „ 1 x FDD
- „ 1 x CF I or CF II card

2.8.3 SATA Drives

3302040

The 3302040 supports two, first generation SATA drives with transfer rates of up to 150Mb/s

2.8.4 IDE HDD Interfaces

The 3302040 system chipset IDE controller supports up to two HDDs with the following specifications:

- „ Supports PIO IDE transfers up to 16MB/s
- „ Supports the following Ultra ATA devices:
 - **Ultra ATA/100**, with data transfer rates up to 100MB/s
 - **Ultra ATA/66**, with data transfer rates up to 66MB/s
 - **Ultra ATA/33**, with data transfer rates up to 66MB/s

2.8.5 CompactFlash Support

A standard CF I or CF II card can be inserted into the compact flash slot on the solder side of the 3302040 PCB.

2.9 Serial Ports

The 3302040 has two high-speed UART serial ports, configured as COM1 and COM2. The serial ports have the following specifications.

- „ 16C550 UART with 16-byte FIFO buffer
- „ 115.2Kbps transmission rate

COM2 can be configured as RS-232, RS-422 or RS-485.

2.10 Real Time Clock

256-byte battery backed CMOS RAM

2.11 System Monitoring

The 3302040 is capable of self-monitoring various aspects of its operating status including:

- „ CPU, chipset, and battery voltage, +3.3V, +5V, and +12V
- „ RPM of cooling fans
- „ CPU and board temperatures (by the corresponding embedded sensors)

2.12 USB Interfaces

The 3302040 has four USB interfaces, two internal (on one pin header connector) and two external. The USB interfaces support USB 2.0.

2.13 BIOS

The 3302040 uses a licensed copy of AWARD BIOS. The features of the flash BIOS used are listed below:

- „ SMIBIOS (DMI) compliant
- „ Console redirection function support
- „ PXE (**P**re-**B**oot **E**xecution **E**nvironment) support
- „ USB booting support

2.14 Operating Temperature and Temperature Control

The maximum and minimum operating temperatures for the 3302040 are listed below.

- „ Minimum Operating Temperature: 0°C (32°F)
- „ Maximum Operating Temperature: 60°C (140°F)

A cooling fan and heat sink must be installed on the CPU. Thermal paste must be smeared on the lower side of the heat sink before it is mounted on the CPU. Heat sinks are also mounted on the northbridge and southbridge chipsets to ensure the operating temperature of these chips remain low.

2.15 Audio Codec

The 3302040 has an integrated RealTek ALC203 codec. The RealTek ALC203 is a 20-bit DAC and 18-bit ADC full-duplex AC'97 2.3 compatible stereo audio CODEC

3302040

designed for PC multimedia systems, including host/soft audio, and AMR/CNR based designs. The codec meets performance requirements for audio on PC99/2001 systems

- „ Single chip with high S/N ratio (>100 dB)
- „ Meets performance requirements for audio on PC2001 systems
- „ Meets Microsoft WHQL/WLP 2.0 audio requirements
- „ 20-bit DAC and 18-bit ADC resolution
- „ 18-bit Stereo full-duplex CODEC with independent and variable sampling rate
- „ Complies with AC'97 2.3 specifications
 - LINE/HP-OUT, MIC-IN and LINE-IN sensing
 - 14.318MHz -> 24.576MHz PLL saves crystal
 - 12.288MHz BITCLK input can be consumed
 - Integrated PCBEEP generator to save buzzer
 - Interrupt capability
 - Page registers and Analog Plug & Play
- „ Support of S/PDIF out is fully compliant with AC'97 rev2.3 specifications
- „ Three analog line-level stereo inputs with 5-bit volume control: LINE_IN, CD, AUX
- „ High quality differential CD input
- „ Two analog line-level mono input: PCBEEP, PHONE-IN
- „ Supports double sampling rate (96KHz) of DVD audio playback
- „ Two software selectable MIC inputs
- „ +6/12/20/30dB boost preamplifier for MIC input
- „ Stereo output with 6-bit volume control
- „ Mono output with 5-bit volume control
- „ Headphone output with 50mW/200hm amplifier
- „ 3D Stereo Enhancement
- „ Multiple CODEC extension capability
- „ External Amplifier Power Down (EAPD) capability
- „ Power management and enhanced power saving features
- „ Stereo MIC record for AEC/BF application
- „ DC Voltage volume control
- „ Auxiliary power to support Power Off CD
- „ Adjustable VREFOUT control
- „ 2 GPIO pins with smart GPIO volume control

- „ 2 Universal Audio Jacks (UAJ)® for front panel
- „ Supports 32K/44.1K/48K/96KHz S/PDIF output
- „ Supports 32K/44.1K/48KHz S/PDIF input
- „ Power support: Digital: 3.3V; Analog: 3.3V/5V
- „ Standard 48-Pin LQFP Package
- „ EAX™ 1.0 & 2.0 compatible
- „ Direct Sound 3D™ compatible
- „ A3D™ compatible
- „ I3DL2 compatible
- „ HRTF 3D Positional Audio
- „ Sensaura™ 3D Enhancement (optional)
- „ 10 Bands of Software Equalizer
- „ Voice Cancellation and Key Shifting in Karaoke mode
- „ AVRack® Media Player

2.16 Power Consumption

Table 2-2 shows the power consumption parameters for the 3302040 when a 333MHz AMD Geode GX 400 is running with a 256MB DDR400 module.

Voltage	Current
+5V	1.15A
+12V	0.28A

Table 2-2: Power Consumption

2.17 Packaged Contents and Optional Accessory Items

2.17.1 Package Contents

The 3302040 is shipped with the following components.

- „ 1x 3302040 single board computer
- „ 1 x Mini jumper pack
- „ 1 x ATA33 Flat cable
- „ 1 x KB/MS cable

3302040

- „ 1 x RS-232 cable
- „ 1 x RS-232/422/485 cable
- „ 2 x SATA cables
- „ 1 x SATA power cable
- „ 1 x Utility CD
- „ 1 x Quick Installation Guide

2.17.2 Optional Accessory Items

The items shown in the list below are optional accessory items are purchased separately.

- „ USB cable
- „ LPT cable

THIS PAGE IS INTENTIONALLY LEFT BLANK

Chapter

3

Connectors and Jumpers

3.1 Peripheral Interface Connectors

Section 3.1.1 shows peripheral interface connector locations. Section 3.1.2 lists all the peripheral interface connectors seen in Section 3.1.1.

3.1.1 3302040 Layout

Figure 3-1 shows the onboard peripheral connectors, external peripheral interface connectors and onboard jumpers.

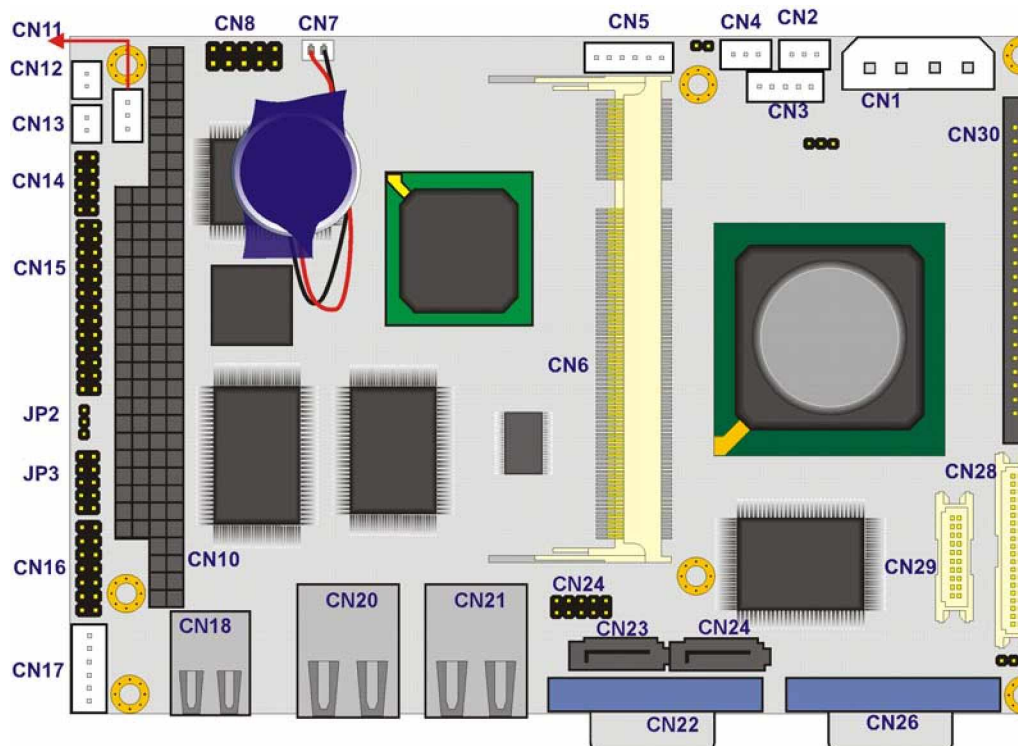

Figure 3-1: Connector and Jumper Locations

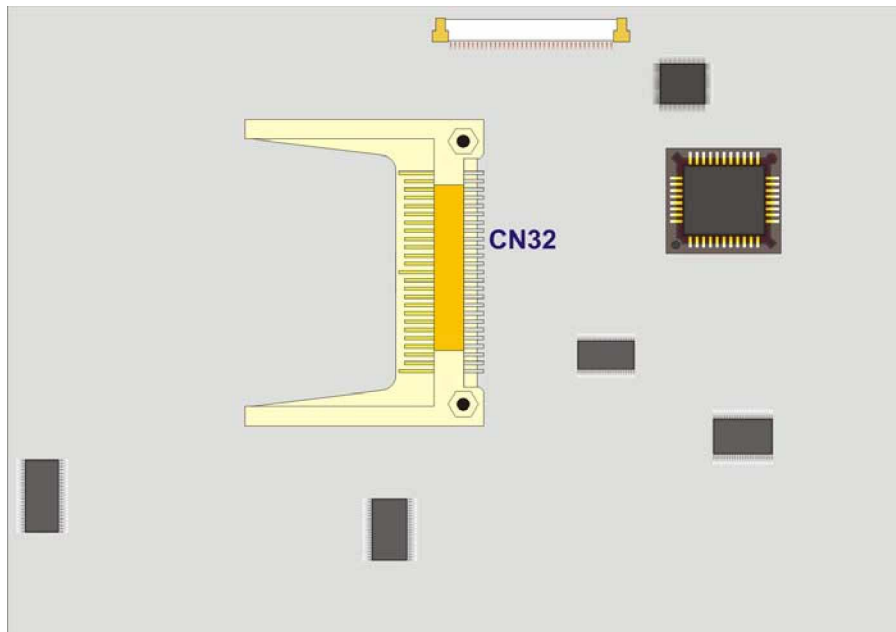

Figure 3-2: Connector and Jumper Locations (Solder Side)

3.1.2 Peripheral Interface Connectors

Table 3-1 shows a list of the peripheral interface connectors on the 3302040. Detailed descriptions of these connectors can be found in **Section 3.2** on **page 27**.

Connector		
AT power connector	4-pin AT power	CN1
ATX power function connector	2-pin wafer	CN11
Audio connector	10-pin header	CN8
Battery connector	2-pin wafer	CN7
Compact Flash (CF) connector	50-pin socket	CN32
Digital I/O (DIO) connector	10-pin header	CN14
Fan connector	3-pin wafer	CN4
IDE Interface connector	44-pin box header	CN30

Inverter power connector	3-pin wafer	CN3
Keyboard/Mouse connector	6-pin wafer	CN17
LED connector	6-pin wafer	CN5
LVDS LCD connector	20-pin crimp	CN29
Parallel port connector	26-pin box header	CN15
Power button connector	3-pin wafer	CN13
PC/104 slot	PC/104 slot	CN10
Reset button connector	2-pin wafer	CN12
RS-232/422/485 serial port connector	14-pin header	CN16
SATA drive connector (150MB/s)	7-pin SATA drive	CN23
SATA drive connector (150MB/s)	7-pin SATA drive	CN25
Suspend power input connector	3-pin wafer	CN2
TFT LCD TTL connector	30-pin crimp	CN28
USB connector (USB 1.1 and USB 2.0)	8-pin header	CN24

Table 3-1: Onboard Peripheral Connectors

3.1.3 External Peripheral Interface Connectors

Table 3-2 lists the rear panel connectors on the 3302040. Detailed descriptions of these connectors can be found in **Section 3.3** on **page 54**.

Connector	Type	Label
Ethernet connector	RJ-45	CN21
Ethernet connector	RJ-45	CN22
RS-232 serial port		CN22
USB port connector	USB	CN18

3302040

VGA connector	HD-D-sub 15 female	CN26
---------------	--------------------	------

Table 3-2: Rear Panel Connectors

3.1.4 Onboard Jumpers

Table 3-3 lists the onboard jumpers. Detailed descriptions of these jumpers can be found in **Chapter 4**.

Description	Label	Type
AT/ATX power mode select	JP1	2-pin header
RS-422/485 select	JP2	3-pin header
COM1/2 RI pin	JP3	10-pin header
LCD voltage select	JP4	3-pin header
CRT/LCD mode select	JP5	5-pin header

Table 3-3: Onboard Jumpers

3.2 Internal Peripheral Connectors

Internal peripheral connectors are found on the motherboard and are only accessible when the motherboard is outside of the chassis. This section has complete descriptions of all the internal, peripheral connectors on the 3302040.

3.2.1 AT Power Input Connector

CN Label:	CN1
CN Type:	4-pin AT power connector (1x4)
CN Location:	See Figure 3-3
CN Pinouts:	See Table 3-4

The AT power connector is connected to an AT power source that powers the system.

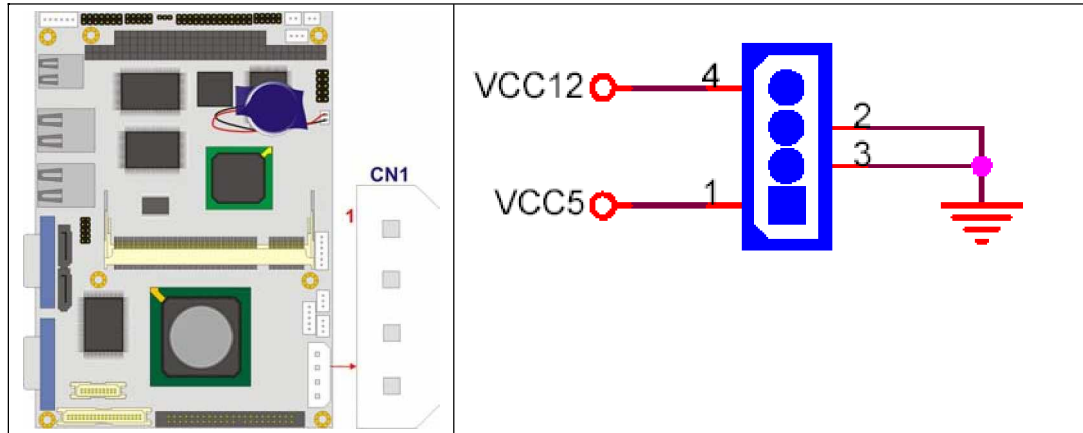

Figure 3-3: AT Power Connector Location

PIN NO.	DESCRIPTION
1	+5V
2	GND
3	GND
4	+12V

Table 3-4: AT Power Connector Pinouts

3.2.2 ATX Power Connector

CN Label:	CN11
CN Type:	3-pin wafer (1x2)
CN Location:	See Figure 3-4
CN Pinouts:	See Table 3-5

The ATX power connector enables ATX power supply functionality on the 3302040.

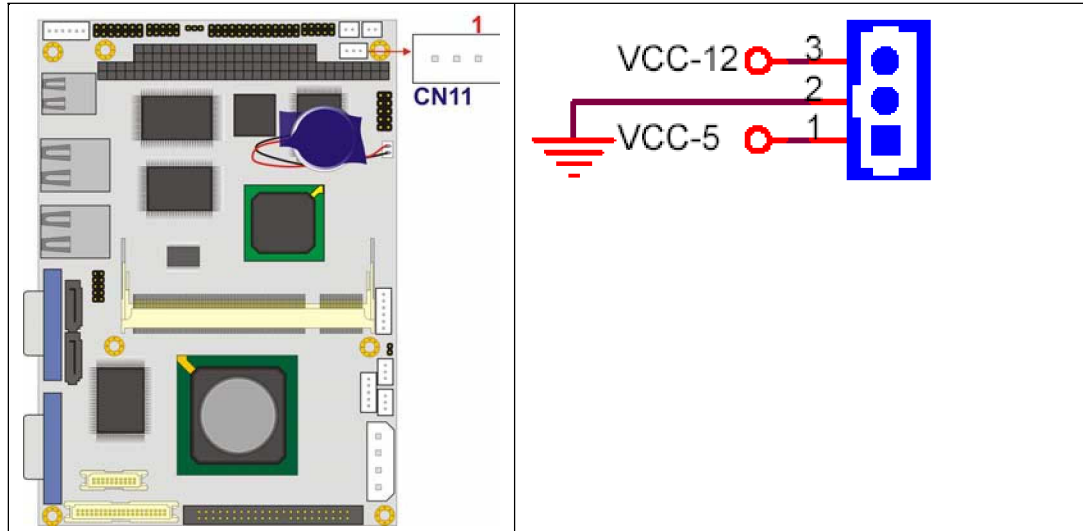

Figure 3-4: ATX Power Connector Location

PIN NO.	DESCRIPTION
1	VCC -5V
2	GROUND
3	VCC -12V

Table 3-5: ATX Power Connector Pinouts

3.2.3 Audio Connector

CN Label:	CN8
CN Type:	10-pin header (2x5)
CN Location:	See Figure 3-5
CN Pinouts:	See Table 3-6

The audio connector is connected to an onboard codec. An external audio connector kit can be connected to the connector to provide sound input and output.

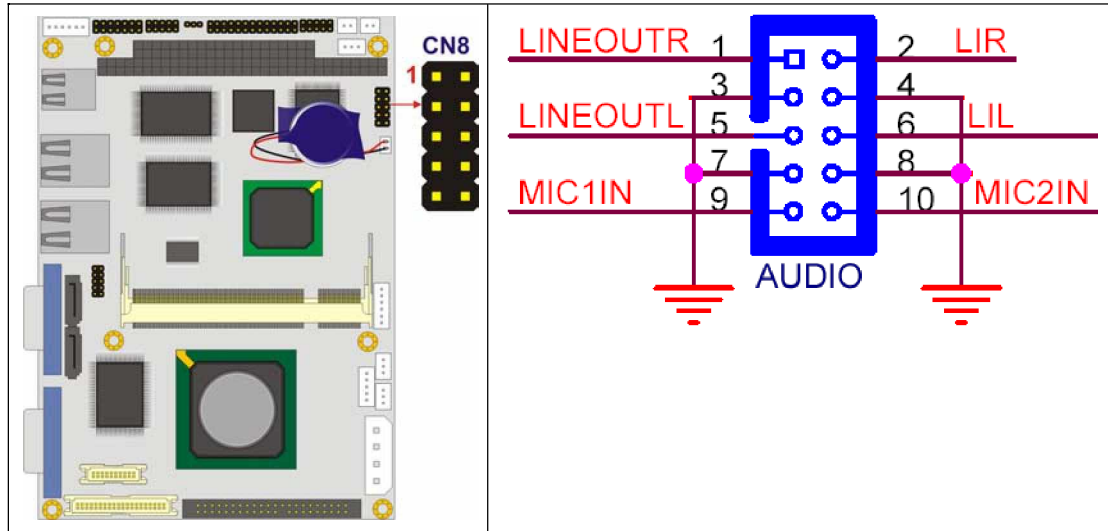

Figure 3-5: Audio Connector Location

PIN NO.	DESCRIPTION	PIN NO.	DESCRIPTION
1	Line Out Right	2	Line In Right
3	GND	4	GND
5	Line Out Left	6	Line In Left
7	GND	8	GND
9	MIC 1	10	MIC 2

Table 3-6: Audio Connector Pinouts

3.2.4 CompactFlash Connector

- CN Label: **CN32** (solder side)
- CN Type: 50-pin socket (2x25)
- CN Location: See **Figure 3-6**
- CN Pinouts: See **Table 3-7**

A CompactFlash memory module is inserted into the CompactFlash socket on the solder side of the PCB.

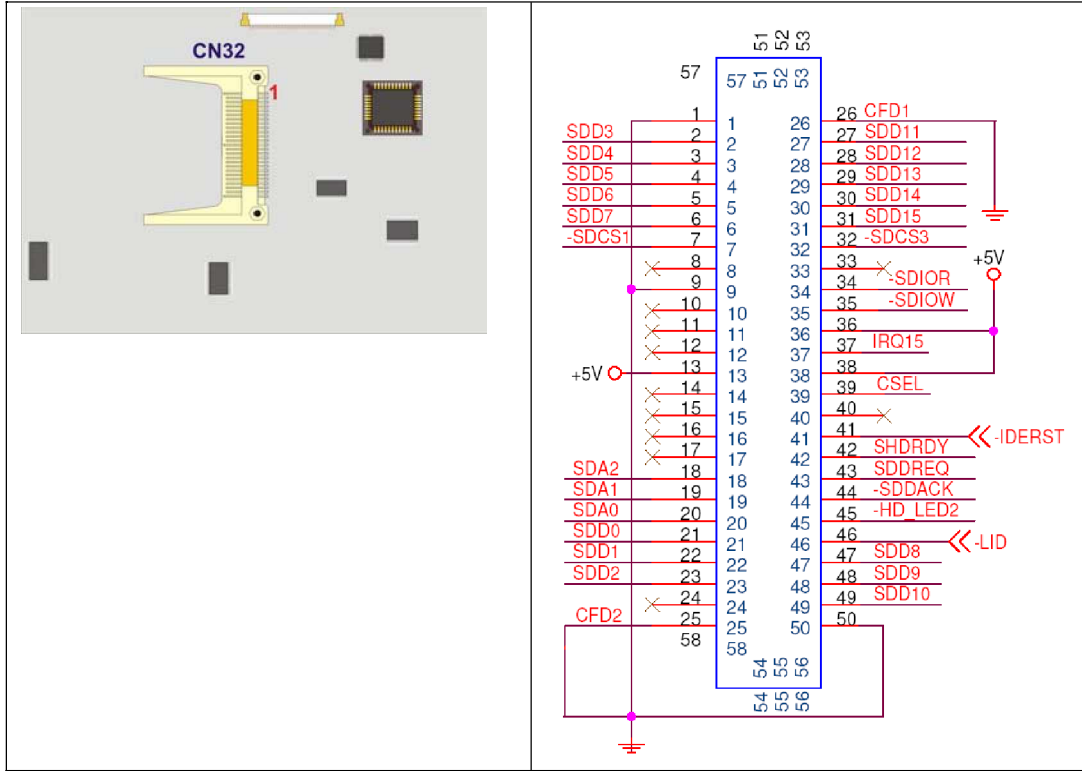

Figure 3-6: CompactFlash Connector Location

PIN NO.	DESCRIPTION	PIN NO.	DESCRIPTION
1	GROUND	26	VCC-IN CHECK1
2	DATA 3	27	DATA 11
3	DATA 4	28	DATA 12
4	DATA 5	29	DATA 13
5	DATA 6	30	DATA 14
6	DATA 7	31	DATA 15
7	SDCS#1	32	SDCS#3
8	N/C	33	N/C
9	GROUND	34	I OR#
10	N/C	35	I OW#
11	N/C	36	VCC_COM
12	N/C	37	IRQ15
13	VCC_COM	38	VCC_COM
14	N/C	39	CSEL

15	N/C	40	N/C
16	N/C	41	HDD_RESET
17	N/C	42	IORDY
18	SA2	43	SDREQ
19	SA1	44	SDACK#
20	SA0	45	HDD_ACTIVE#
21	DATA 0	46	66DET
22	DATA 1	47	DATA 8
23	DATA 2	48	DATA 9
24	N/C	49	DATA 10
25	VCC-IN CHECK2	50	GROUND

Table 3-7: CompactFlash Connector Pinouts

3.2.5 Digital Input/Output (DIO) Connector

CN Label:	CN14
CN Type:	10-pin header (2x5)
CN Location:	See Figure 3-7
CN Pinouts:	See Table 3-8

The DIO connector is managed through a Super I/O chip. The DIO connector pins are user programmable.

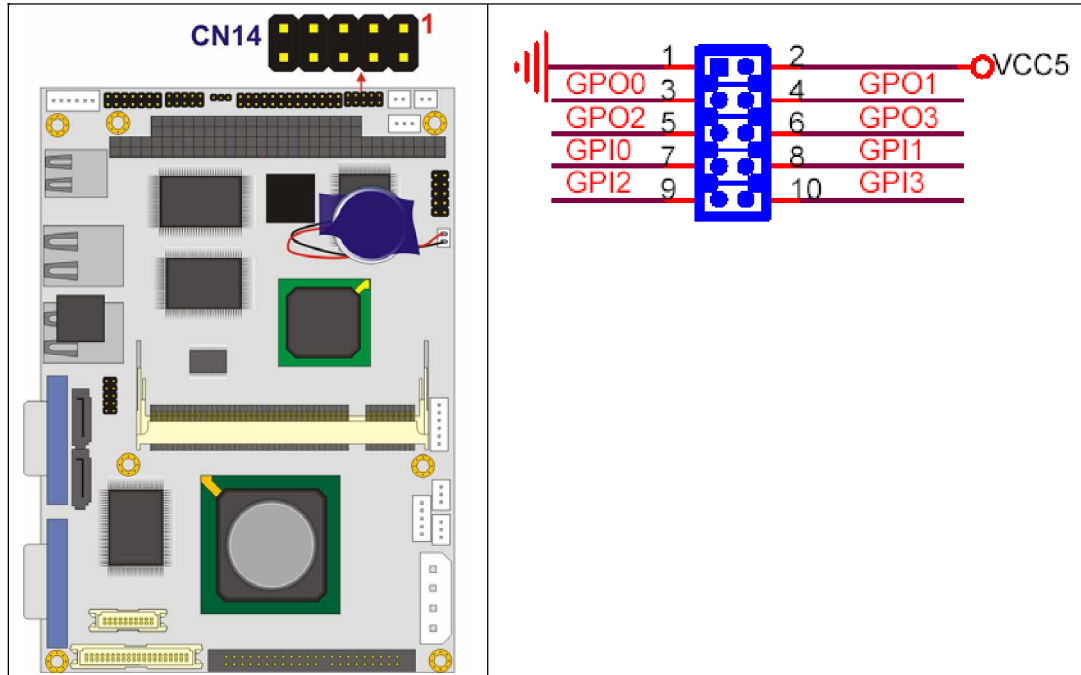

Figure 3-7: DIO Connector Connector Locations

PIN NO.	DESCRIPTION	PIN NO.	DESCRIPTION
1	GND	2	VCC
3	Output 0	4	Output 1
5	Output 2	6	Output 3
7	Input 0	8	Input 1
9	Input 2	10	Input 3

Table 3-8: DIO Connector Connector Pinouts

3.2.6 Fan Connector

- CN Label: **CN2**
- CN Type: 3-pin wafer
- CN Location: See **Figure 3-8**
- CN Pinouts: See **Table 3-9**

The cooling fan connector provides a 5V, 500mA current to a system cooling fan. The connector has a "rotation" pin to get rotation signals from fans and notify the system so the system BIOS can recognize the fan speed. Please note that only specified fans can issue the rotation signals.

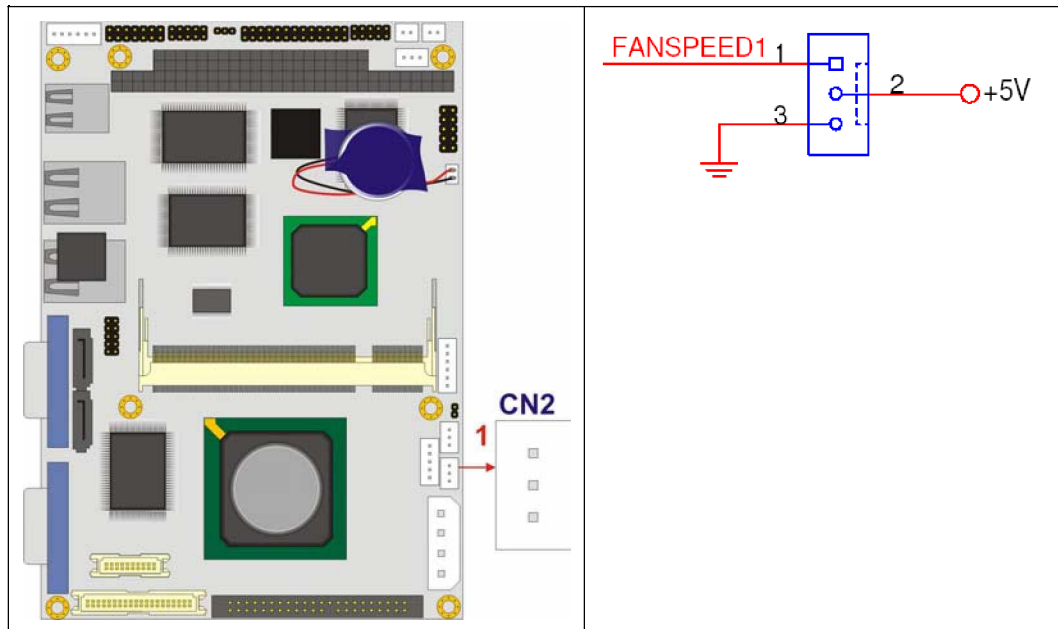

Figure 3-8: Fan Connector Location

PIN NO.	DESCRIPTION
1	Fan Speed
2	+5V
3	Ground

Table 3-9: Fan Connector Pinouts

3.2.7 IDE Connector

CN Label: **CN30**

CN Type: 40-pin box header (2x20)

CN Location: See **Figure 3-9**

CN Pinouts: See **Table 3-10**

One 40-pin IDE device connector on the 3302040 motherboard supports connectivity to two Ultra ATA 33 IDE devices with data transfer rates up to 100MB/s.

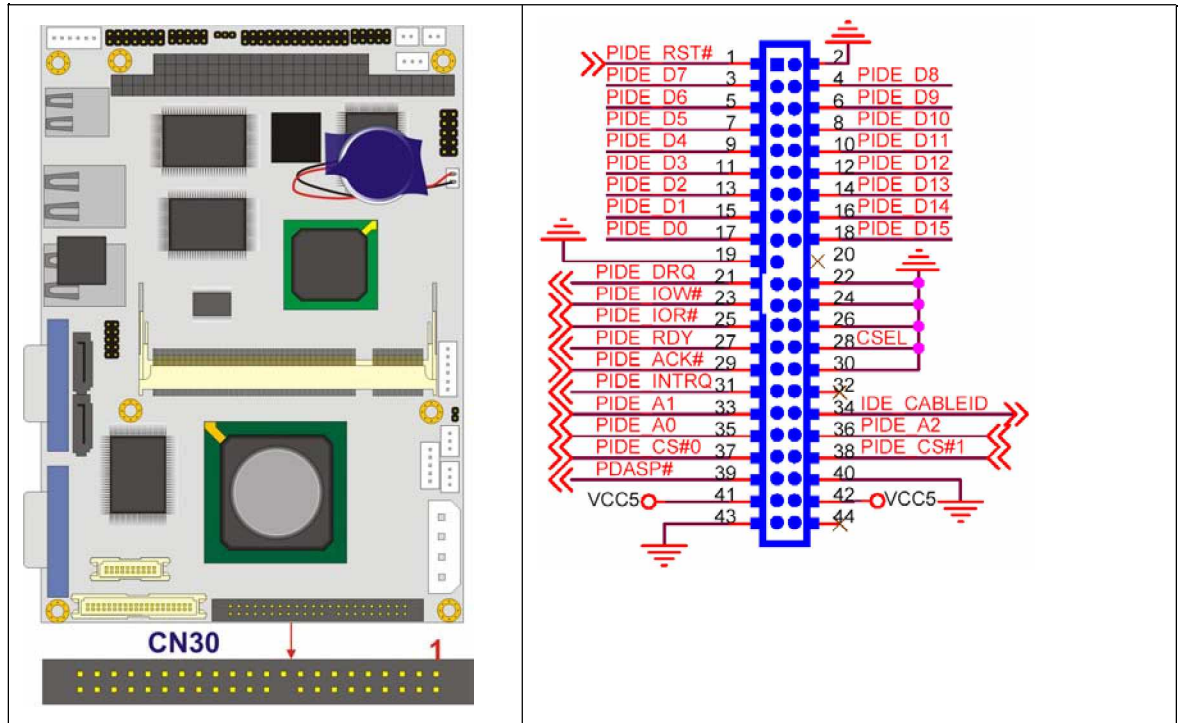

Figure 3-9: Primary IDE Device Connector Locations

PIN NO.	DESCRIPTION	PIN NO.	DESCRIPTION
1	RESET#	2	GROUND
3	DATA 7	4	DATA 8
5	DATA 6	6	DATA 9
7	DATA 5	8	DATA 10
9	DATA 4	10	DATA 11
11	DATA 3	12	DATA 12
13	DATA 2	14	DATA 13
15	DATA 1	16	DATA 14
17	DATA 0	18	DATA 15
19	GROUND	20	N/C

21	IDE DRQ	22	GROUND
23	IOW#	24	GROUND
25	IOR#	26	GROUND
27	IDE CHRDY	28	GROUND-DEFAULT
29	IDE DACK	30	GROUND
31	INTERRUPT	32	N/C
33	SA1	34	P66DET
35	SA0	36	SA2
37	HDC CS0#	38	HDC CS1#
39	HDD ACTIVE#	40	GROUND

Table 3-10: Primary IDE Connector Pinouts

3.2.8 Inverter Power Connector

CN Label:	CN3
CN Type:	5-pin header (1x5)
CN Location:	See Figure 3-10
CN Pinouts:	See Table 3-11

The inverter connector is connected to the LCD backlight.

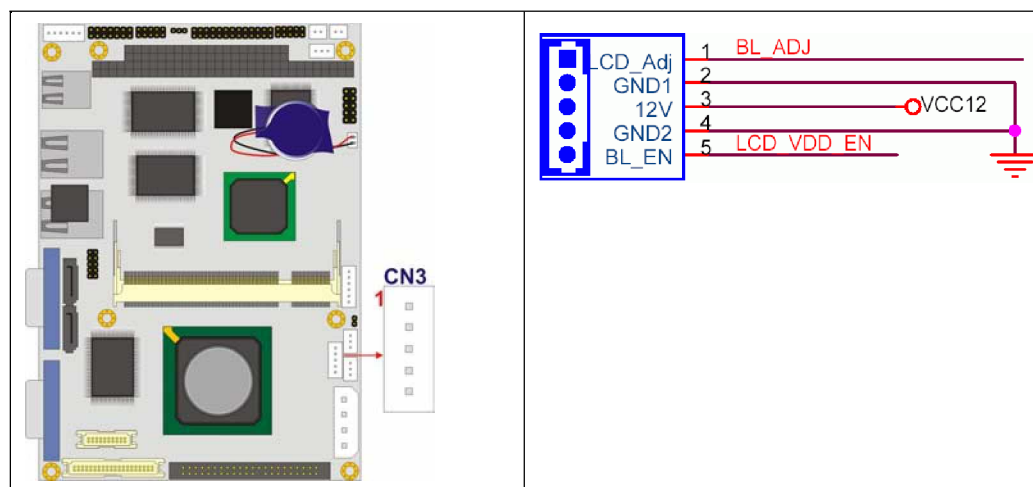

Figure 3-10: Inverter Connector Location

PIN NO.	DESCRIPTION
1	BL_ADJ
2	GND
3	12V
4	GND
5	VDD_EN

Table 3-11: Inverter Power Connector Pinouts

3.2.9 Keyboard and Mouse Connector

CN Label:	CN17
CN Type:	6-pin wafer (1x6)
CN Location:	See Figure 3-11
CN Pinouts:	See Table 3-12

The keyboard and mouse connector can be connected to a standard PS/2 cable or PS/2 Y-cable to add keyboard and mouse functionality to the system.

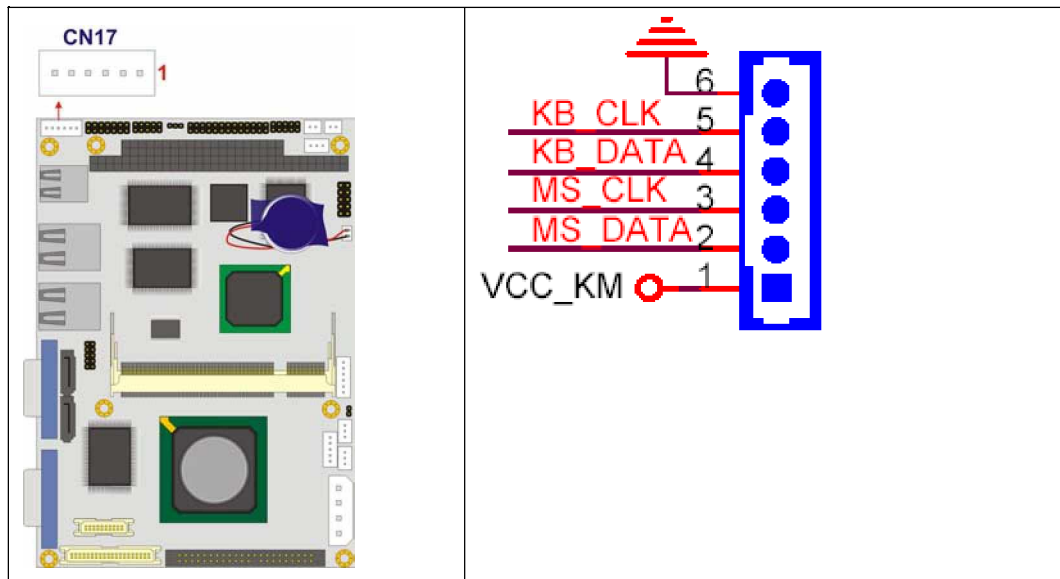

Figure 3-11: Keyboard Connector Location

PIN NO.	DESCRIPTION
1	+5V KB DATA
2	MS DATA
3	MS CLK
4	KB DATA
5	KB CLK
6	GROUND

Table 3-12: Keyboard Connector Pinouts

3.2.10 LED Connector

CN Label:	CN5
CN Type:	6-pin wafer (1x6)
CN Location:	See Figure 3-12
CN Pinouts:	See Table 3-13

The LED connector is connected to LED power and HDD LED indicators locate on the chassis in which the 3302040 is installed.

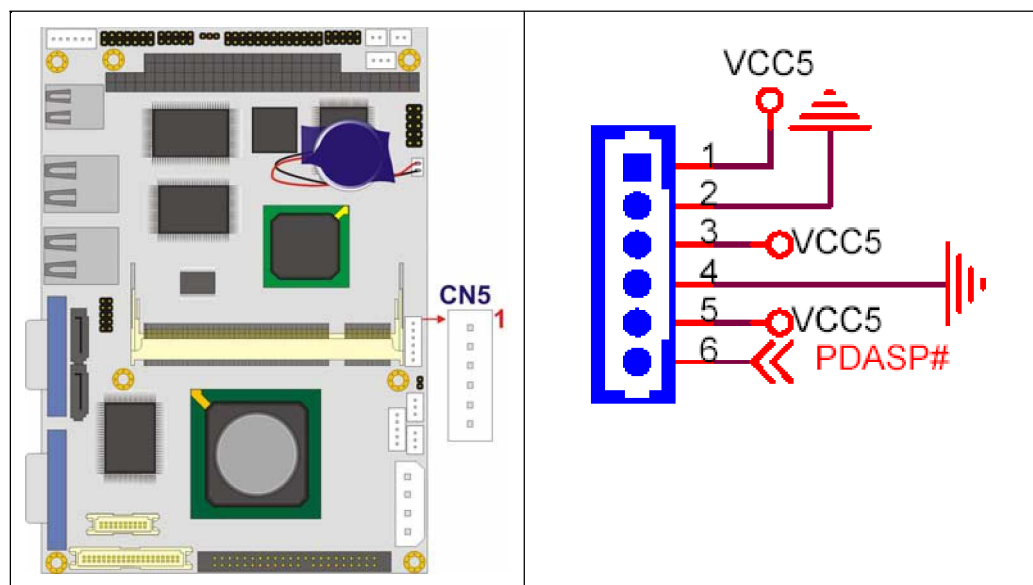

Figure 3-12: LED Connector Location

PIN NO.	DESCRIPTION
1	+5V
2	GND
3	PWR LED+
4	PWR LED-
5	HDD LED+
6	HDD LED-

Table 3-13: LED Connector Pinouts

3.2.11 LCD LVDS Connector

CN Label:	CN29
CN Type:	20-pin crimp (2x10)
CN Location:	See Figure 3-13
CN Pinouts:	See Figure 3-13

The TFT LCD LVDS can be connected to a TFT LCD screen directly.

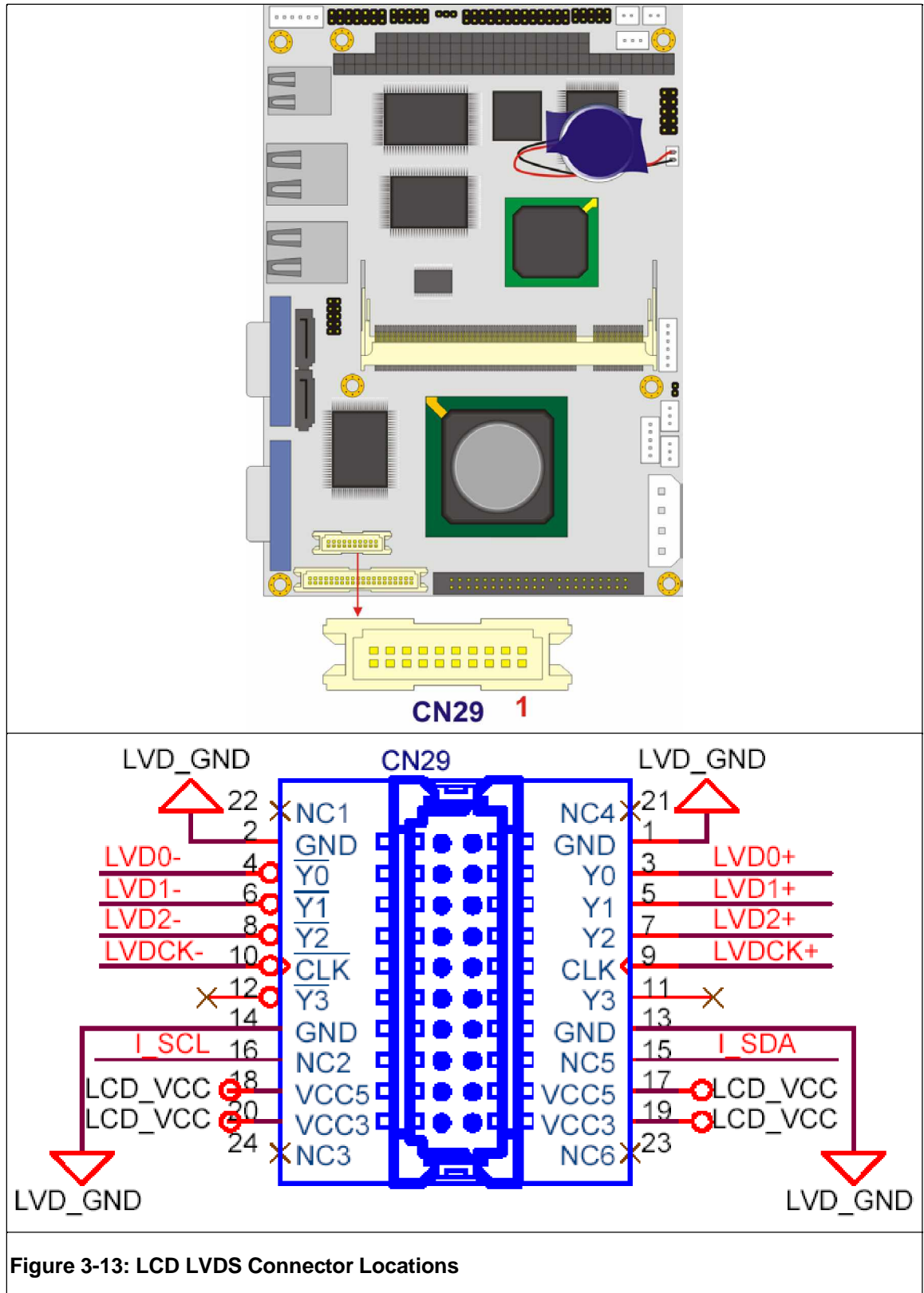

PIN	DESCRIPTION	PIN	DESCRIPTION
1	GND	2	GND
3	LVDS_Y0+	4	LVDS_Y0-
5	LVDS_Y1+	6	LVDS_Y1-
7	LVDS_Y2+	8	LVDS_Y2-
9	LVDS_CLK+	10	LVDS_CLK-
11	NC	12	NC
13	GND	14	GND
15	NC	16	NC
17	LCD_VCC	18	LCD_VCC
19	LCD_VCC	20	LCD_VCC

Table 3-14: LCD LVDS Connector Pinouts

3.2.12 LCD TTL Connector

CN Label:	CN28
CN Type:	30-pin crimp (2x15)
CN Location:	See
CN Pinouts:	See

The TFT LCD LVDS can be connected to a TFT LCD screen directly.

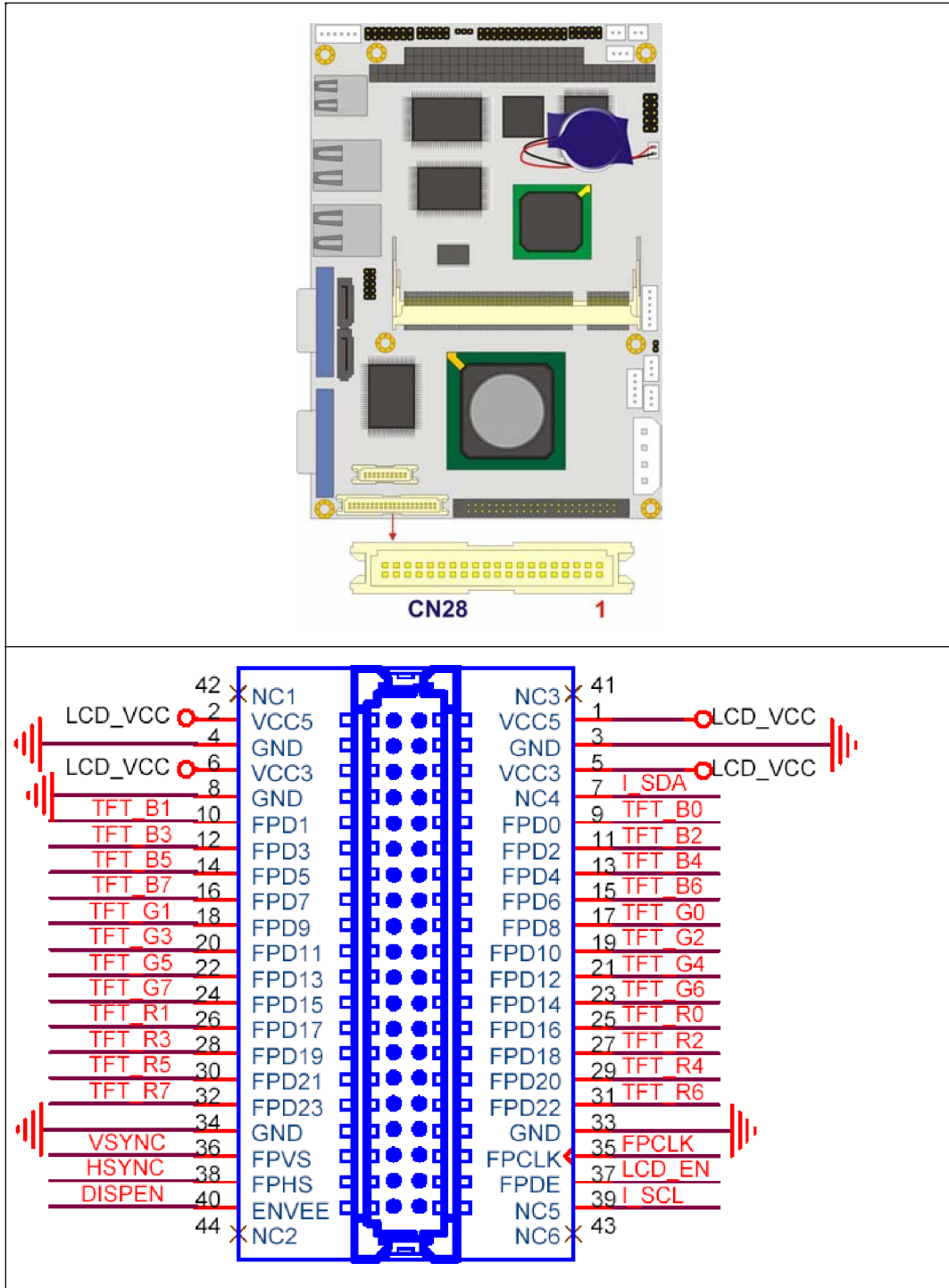

Figure 3-14: LCD TTL Connector Pinout Locations

PIN NO.	DESCRIPTION	PIN NO.	DESCRIPTION
1	LCD_Vcc	2	LCD_Vcc
3	GND	4	GND
5	LCD_Vcc	6	LCD_Vcc
7	I_SDA	8	GND
9	TFT_B0	10	TFT_B1
11	TFT_B2	12	TFT_B3
13	TFT_B4	14	TFT_B5
15	TFT_B6	16	TFT_B7
17	TFT_G0	18	TFT_G1
19	TFT_G2	20	TFT_G3
21	TFT_G4	22	TFT_G5
23	TFT_G6	24	TFT_G7
25	TFT_R0	26	TFT_R1
26	TFT_R2	28	TFT_R3
29	TFT_R4	30	TFT_R5
31	TFT_R6	32	TFT_R7
33	GND	34	GND
35	FPCLK	36	VSYNC
37	LCD_EN	38	HSYNC
39	I_SCL	40	DISP_EN

Table 3-15: TFT LCD TTL Port Connector Pinouts

3.2.13 Parallel Port Connector

CN Label: **CN15**

CN Type: 26-pin box header

CN Location: See **Figure 3-15**

CN Pinouts: See **Table 3-16**

The 3302040 has one 26-pin header that can be connected to a parallel port connector interface or some other parallel port device such as a printer.

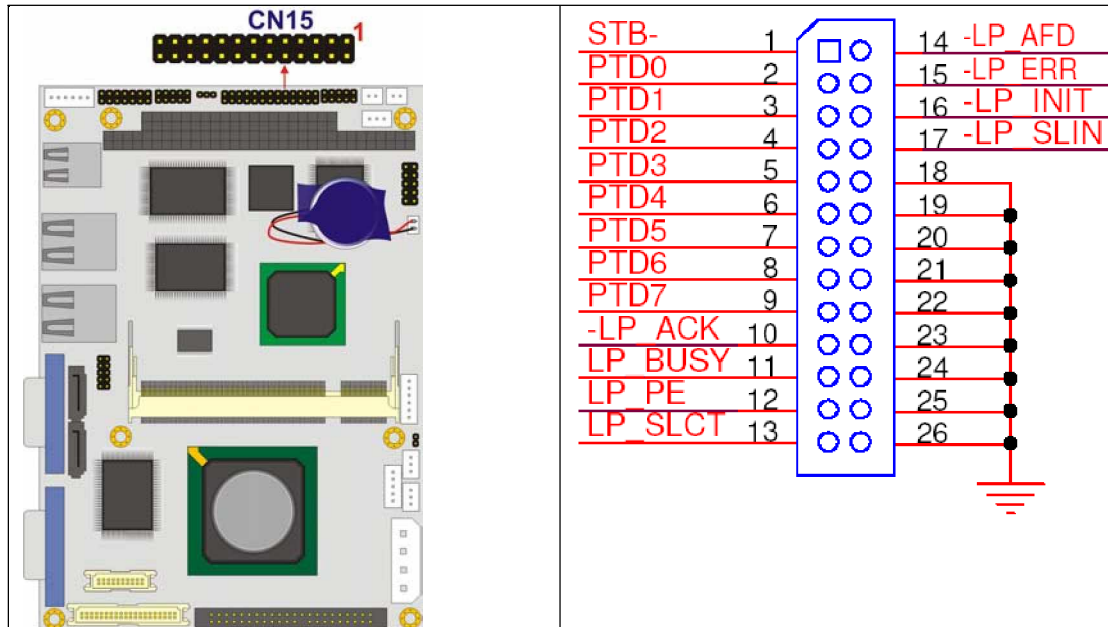

Figure 3-15: Parallel Port Connector Location

PIN NO.	DESCRIPTION	PIN NO.	DESCRIPTION
1	STROBE#	2	DATA 0
3	DATA 1	4	DATA 2
5	DATA 3	6	DATA 4
7	DATA 5	8	DATA 6
9	DATA 7	10	ACKNOWLEDGE
11	BUSY	12	PAPER EMPTY
13	PRINTER SELECT	14	AUTO FORM FEED #
15	ERROR#	16	INITIALIZE
17	PRINTER SELECT LN#	18	GROUND
19	GROUND	20	GROUND
21	GROUND	22	GROUND
23	GROUND	24	GROUND
25	GROUND	26	NC

Table 3-16: Parallel Port Connector Pinouts

3.2.14 PC/104 Slot

- CN Label: **CN10**
- CN Type: 104-pin PC/104 slot
- CN Location: See **Figure 3-16**
- CN Pinouts: See **Table 3-17**

The PC/104 slot enables a PC/104 compatible expansion module to be connected to the board.

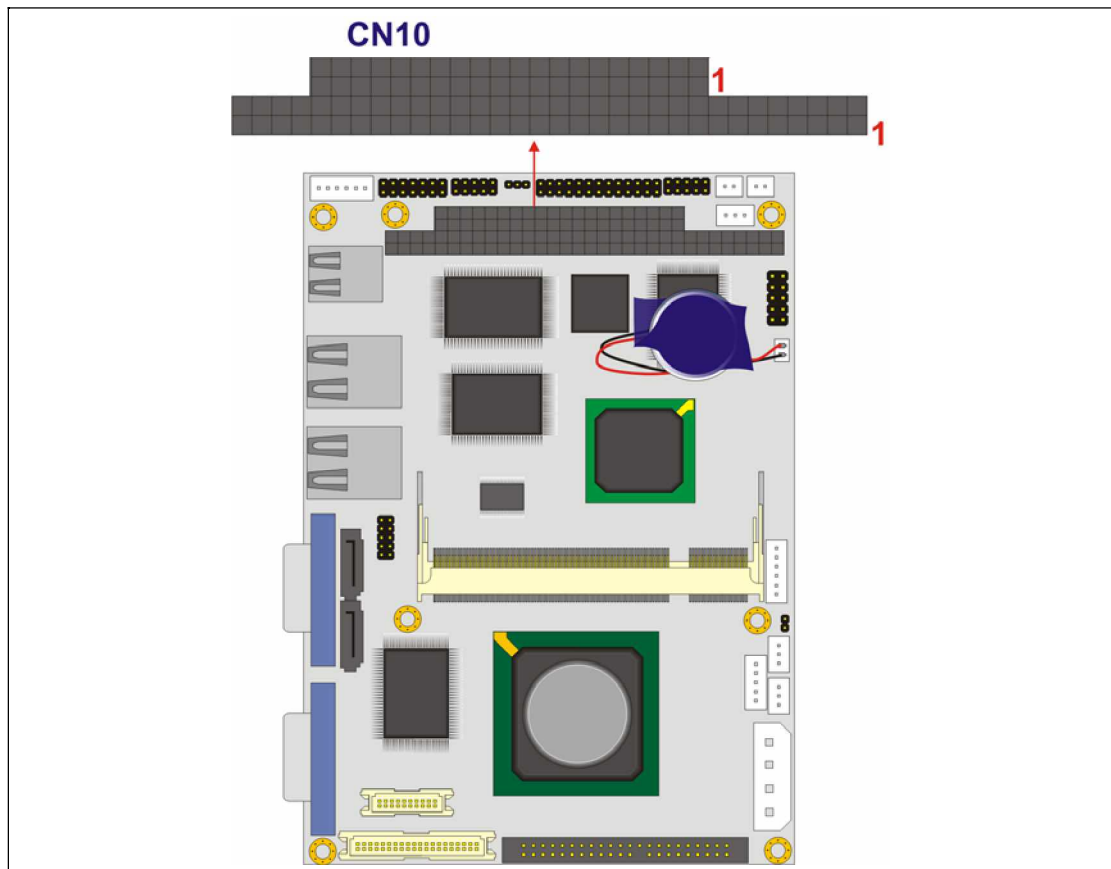

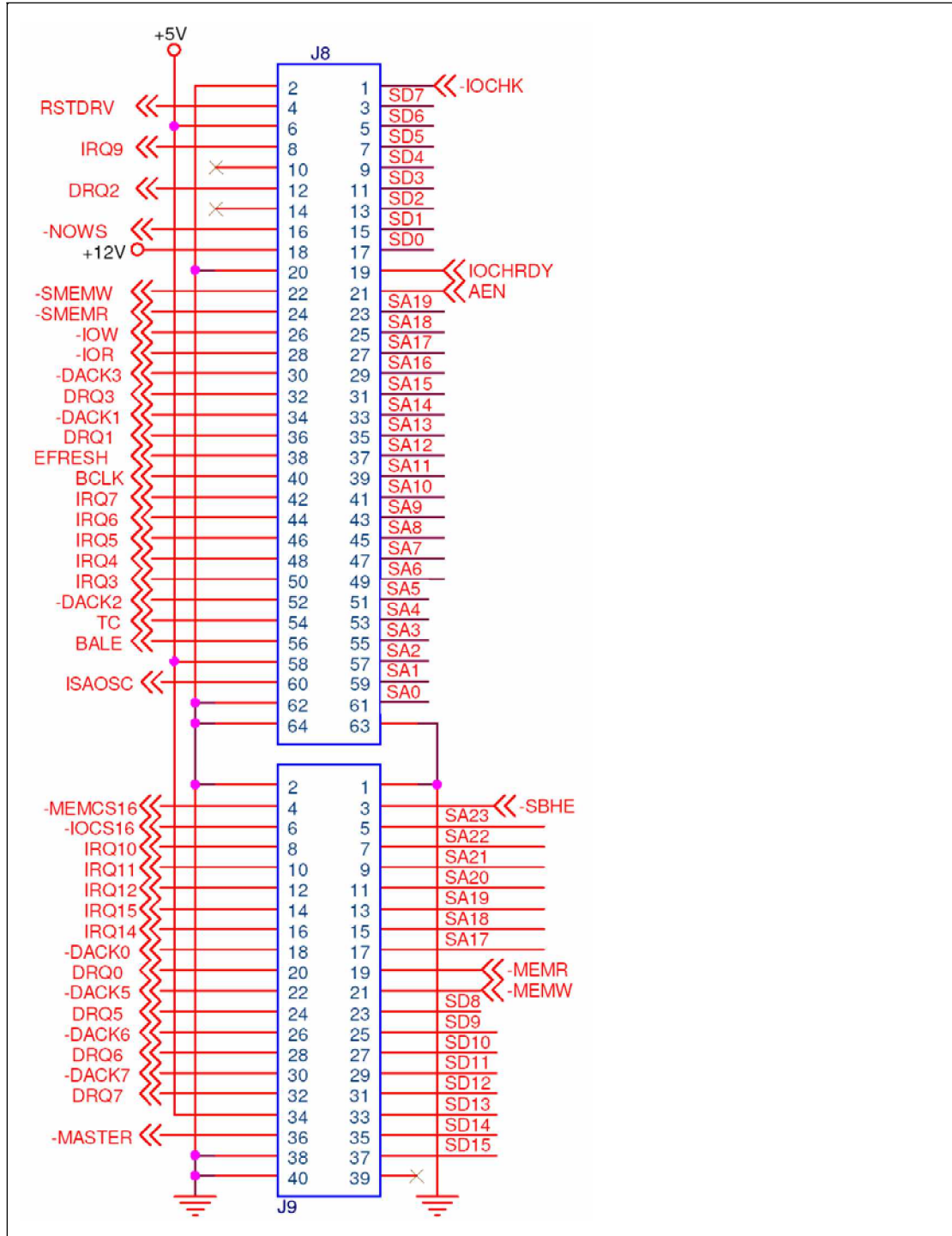

Figure 3-16: PC/104 Slot Location

Pin No.	Column A	Column B	Column C	Column D
---------	----------	----------	----------	----------

1	IOCHK-	GROUND	GROUND	GROUND
2	SD7	RSTDRV	SBHE-	MCS16-
3	SD6	+5V	SA23	IOCS16-
4	SD5	IRQ9	SA22	IRQ10
5	SD4	-5V	SA21	IRQ11
6	SD3	DREQ2	SA20	IRQ12
7	SD2	-12V	SA19	IRQ15
8	SD1	ZWS-	SA18	IRQ14
9	SD0	+12V	SA17	DACK0-
10	IOCHRDY	GROUND	MEMR-	DREQ0
11	AEN	SMEMW-	MEMW-	DACK5-
12	SA19	SMEMR-	SD8	DRREQ5
13	SA18	IOW-	SD9	DACK6-
14	SA17	IOR-	SD10	DREQ6
15	SA16	DACK3-	SD11	DACK7-
16	SA15	DREQ3	SD12	DREQ7
17	SA14	DACK1-	SD13	+5V
18	SA13	DREQ1	SD14	MASTER-
19	SA12	REFRESH-	SD15	GROUND
20	SA11	ISACLK	NC	GROUND
21	SA10	IRQ7		
22	SA9	IRQ6		
23	SA8	IRQ5		
24	SA7	IRQ4		
25	SA6	IRQ3		
26	SA5	DACK2-		
27	SA4	TC		
28	SA3	BALE		
29	SA2	+5V		
30	SA1	ISA_OSC		
31	SA0	GROUND		

32	GROUND	GROUND		
----	--------	--------	--	--

Table 3-17: PC/104 Slot Connector Pinouts

3.2.15 Power Switch Connector

CN Label:	CN13
CN Type:	2-pin wafer (1x2)
CN Location:	See Figure 3-17
CN Pinouts:	See Table 3-18

The power switch connector is connected to the reset button on the external chassis.

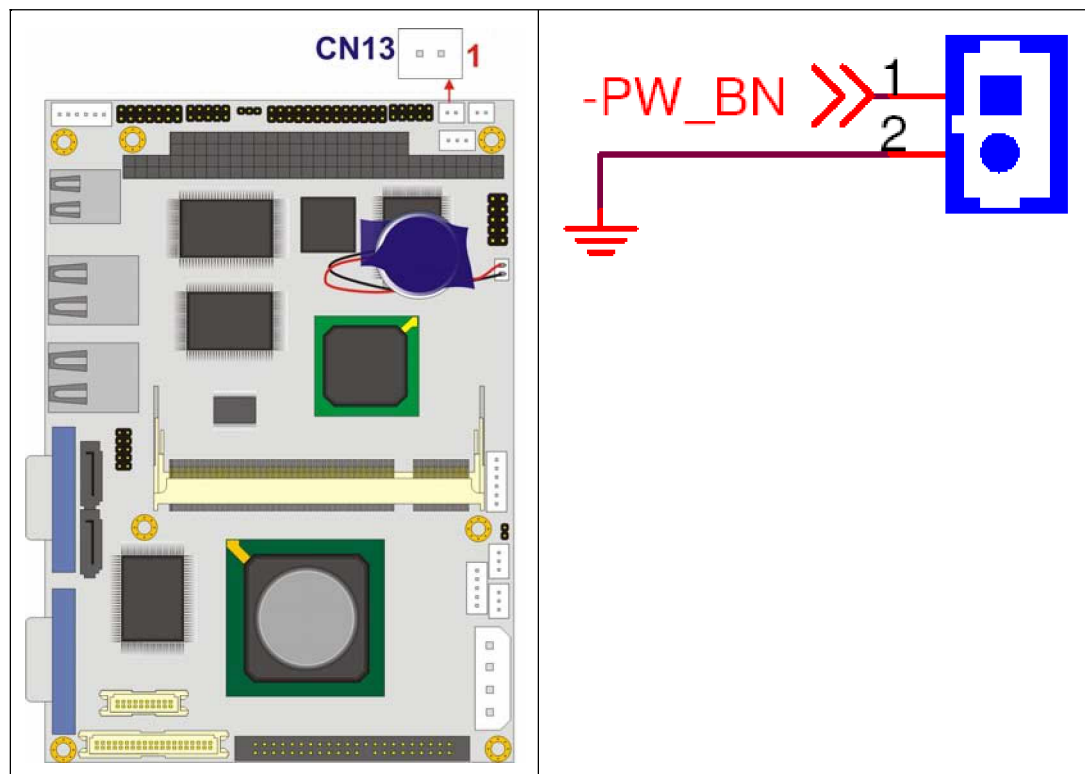

Figure 3-17: Power Switch Connector Locations

PIN NO.	DESCRIPTION
1	PWRBTN#
2	GND

Table 3-18: Power Switch Connector Pinouts

3.2.16 Reset Button Connector

- CN Label: **CN12**
- CN Type: 2-pin wafer (1x2)
- CN Location: See **Figure 3-18**
- CN Pinouts: See **Table 3-19**

The reset button connector is connected to the reset button on the external chassis.

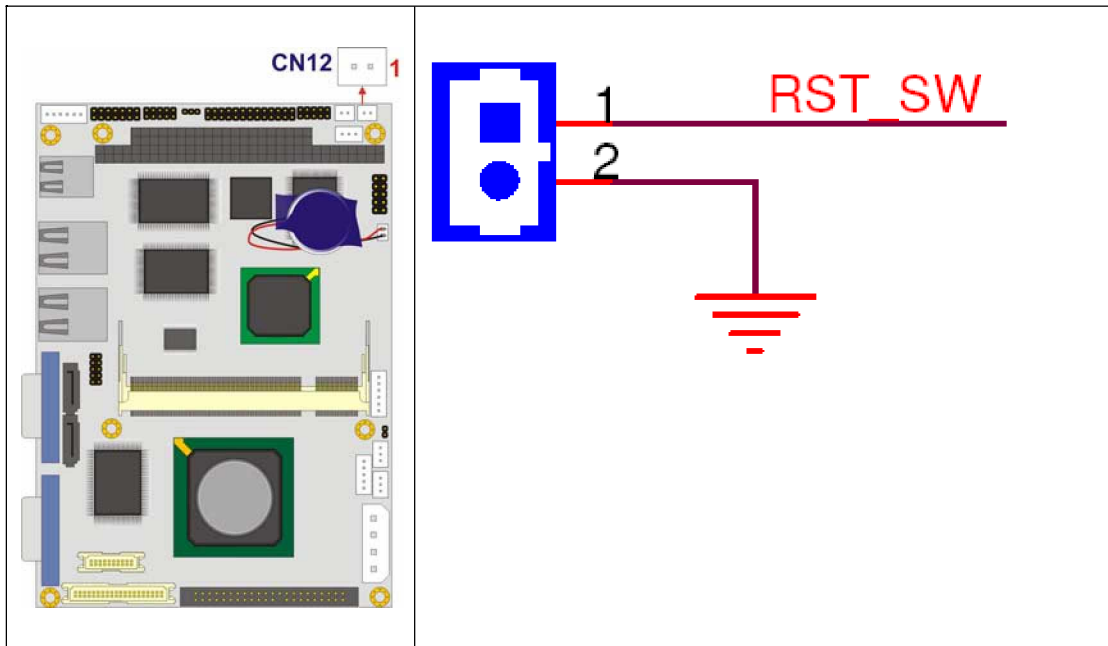

Figure 3-18: Reset Button Connector Locations

PIN NO.	DESCRIPTION
1	Reset Switch

2	GND
---	-----

Table 3-19: Reset Button Connector Pinouts

3.2.17 RS-232/422/485 Serial Port Connectors

- CN Label: **CN16**
- CN Type: 14-pin box header (2x7)
- CN Location: See **Figure 3-19**
- CN Pinouts: See **Table 3-20**

The serial port connector connects to an RS-232, RS-422 or RS-485 serial port devices.

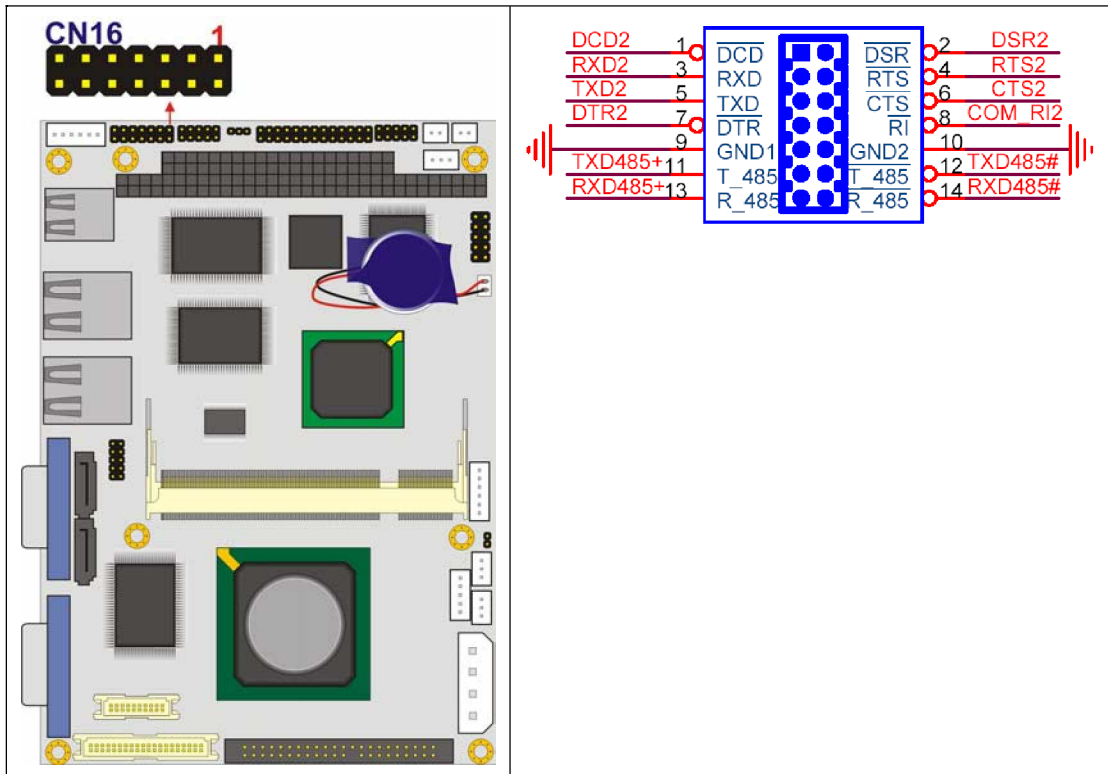

Figure 3-19: RS-232 Serial Port Connector Locations

PIN NO.	DESCRIPTION	PIN NO.	DESCRIPTION
1	DCD	2	DSR

3	RXD	4	RTS
5	TXD	6	CTS
7	DTR	8	RI
9	GROUND	10	GROUND
11	TXD485+	12	TXD485#
13	RXD485+	14	RXD485#

Table 3-20: RS-232/422/485 Serial Port Connector Pinouts

3.2.18 SATA Drive Connectors

- CN Label: **CN23 and CN25**
- CN Type: 7-pin SATA drive connectors
- CN Location: See **Figure 3-20**
- CN Pinouts: See **Table 3-21**

The two SATA drive connectors are connected to two first generation SATA drives. First generation SATA drives transfer data at speeds as high as 150Mb/s.

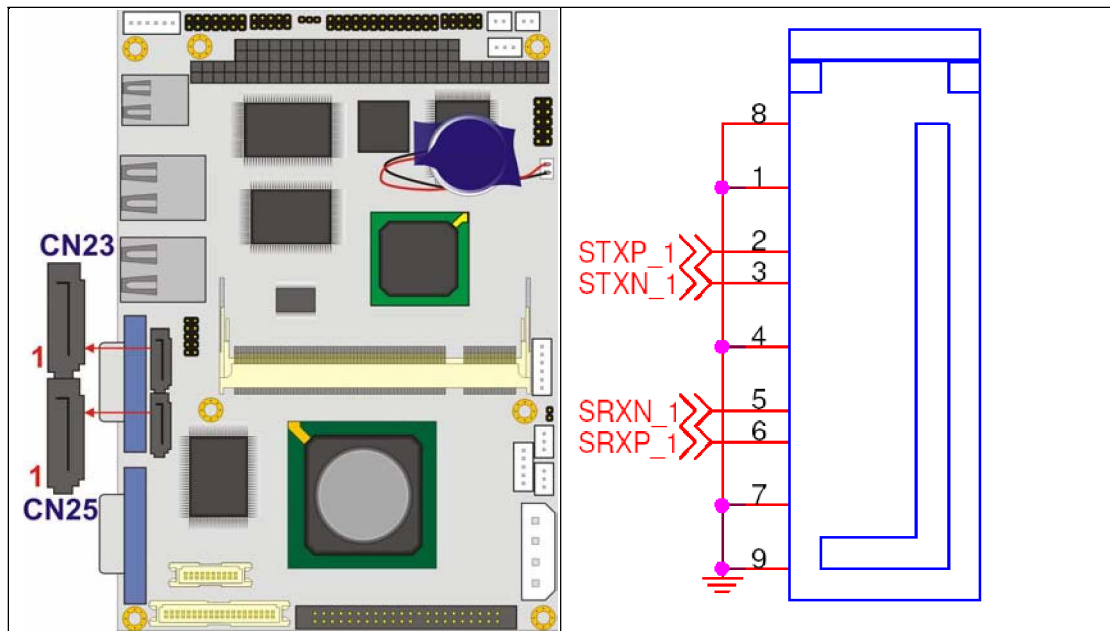

Figure 3-20: SATA Drive Connector Locations

PIN NO.	DESCRIPTION
1	GND
2	TX+
3	TX-
4	GND
5	RX-
6	RX+
7	GND

Table 3-21: SATA Drive Connector Pinouts

3.2.19 Suspend Power Input

CN Label:	CN2
CN Type:	3-pin wafer (1x3)
CN Location:	See Figure 3-21
CN Pinouts:	See Table 3-22

The suspend power connector is located next to the main AT power connector.

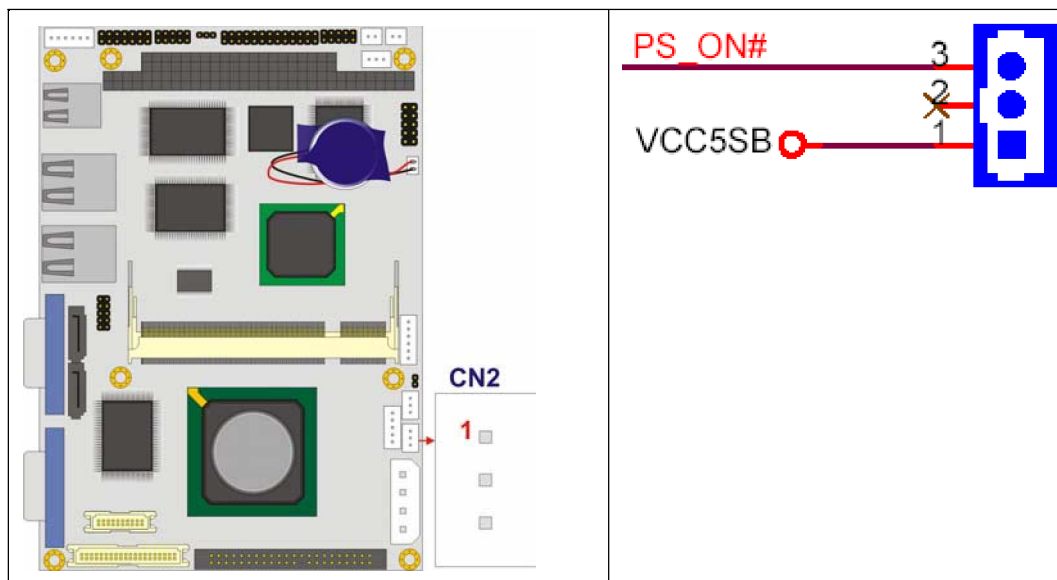

Figure 3-21: Suspend Power Connector Location

PIN NO.	DESCRIPTION
1	PS_ON#
3	NC
5	VCC 5VSB

Table 3-22: Suspend Power Connector Pinouts

3.2.20 Internal USB Connectors

CN Label:	CN24
CN Type:	8-pin header (2x4)
CN Location:	See Figure 3-22
CN Pinouts:	See Table 3-23

The two 2x4 USB pin connectors provide connectivity to four additional USB 2.0 ports. The USB connectors can support two USB devices each. The USB ports are used for I/O bus expansion.

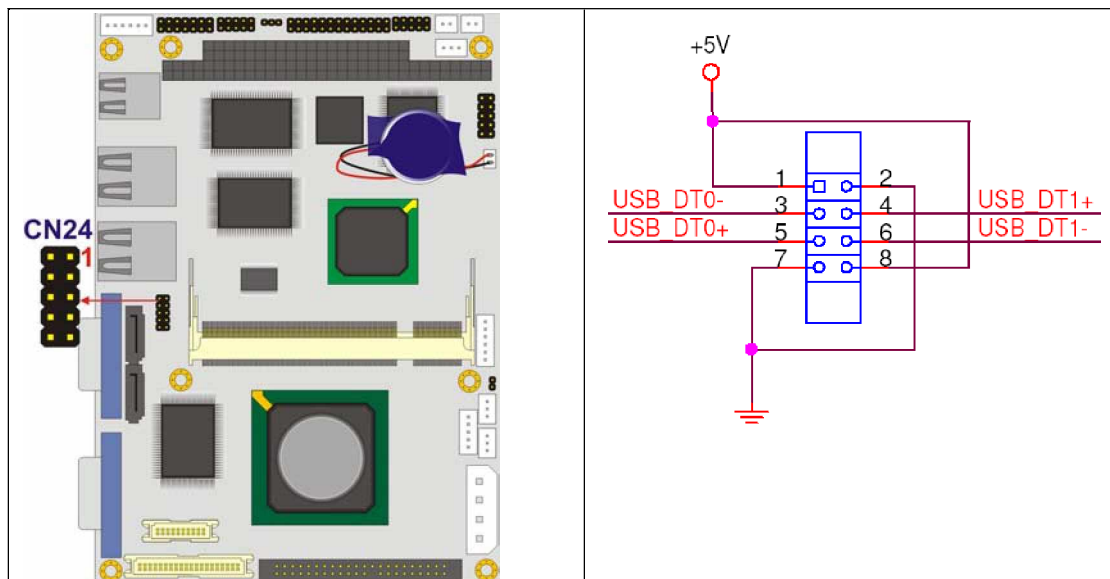

Figure 3-22: USB Connector Pinout Locations

PIN NO.	DESCRIPTION	PIN NO.	DESCRIPTION
1	VCC_USB	2	GND
3	DATA0-	4	DATA1+
5	DATA0+	6	DATA1-
7	GND	8	VCC_USB

Table 3-23: USB Port Connector Pinouts

3.3 External Interface Connectors

3.3.1 External Interface Connector Overview

Figure 3-23 shows the 3302040 motherboard external interface connectors. The 3302040 on-board external interface connectors are listed below and shown in **Figure 3-23**:

- „ 1 x USB combo port
- „ 2 x Ethernet connector
- „ 1 x Serial communications port
- „ 1 x VGA port

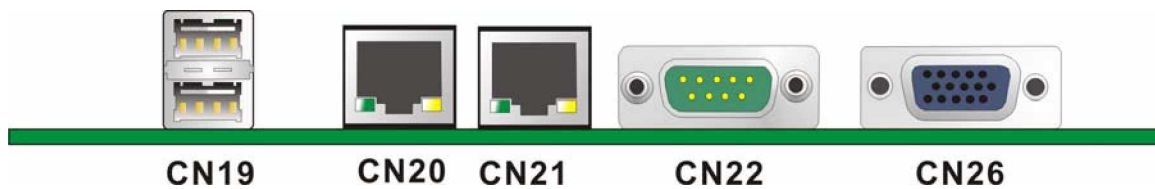

Figure 3-23: 3302040 On-board External Interface Connectors

3.3.2 USB Combo Port

- CN Label: **CN19**
- CN Type: USB Combo port
- CN Location: See **Figure 3-23**
- CN Pinouts: See Table 3-24

3302040

The USB combo port provides connectivity to additional USB devices through an adapter cable. Various adapters may come with USB ports on a slot bracket or ports that can be attached to D-SUB openings on a chassis. USB devices connect directly to the USB connectors on the rear panel.

PIN	DESCRIPTION	PIN	DESCRIPTION
1	5V	2	GND
3	USBP2N	4	USBP3P
5	USBP2P	6	USBP3N
7	GND	8	5V

Table 3-24: J6 Connector Pinouts

3.3.3 Ethernet Connector

CN Label: **CN20 and CN 21**

CN Type: **RJ-45**

CN Location: See **Figure 3-23**

CN Pinouts: See Table 3-25

A 1Gb connection can be made between the Ethernet connector and a Local Area Network (LAN) through a network hub.

PIN	DESCRIPTION	PIN	DESCRIPTION
1	TX-	5	N/C
2	N/C	6	RX-
3	TX-	7	N/C
4	RX+	8	N/C

Table 3-25: J7 Connector Pinouts

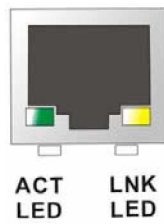

Figure 3-24: J7 Connector

The RJ-45 Ethernet connector has two status LEDs, one green and one yellow. The green LED indicates activity on the port and the yellow LED indicates the port is linked.

SPEED LED		LINK LED	
Status	Description	Status	Description
GREEN	ON: 100MB OFF: 10MB	YELLOW	ON: Linked Flashing: Activity

Table 3-26: J7 Connector LEDs

3.3.4 Serial Communications COM 1 and COM2 Connector

- CN Label: **CN22**
- CN Type: RS-232 serial connector
- CN Location: See **Figure 3-23**
- CN Pinouts: See **Table 3-27** and **Figure 3-25**

The RS-232 serial connector provides serial connection in the RS-232 mode.

PIN	DESCRIPTION	PIN	DESCRIPTION
1	DCD1	2	DSR1
3	RX1	4	RTS1
5	TX1	6	CTS1
7	DTR1	8	RI1
9	GND		

Table 3-27: COM1 Pinouts

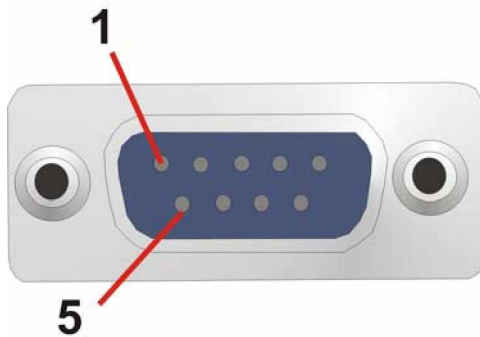

Figure 3-25: COM1 Pinout Locations

3.3.5 VGA Connector

CN Label: **CN26**

CN Type: See VGA Connector

CN Location: See **Figure 3-23**

CN Pinouts: See **Figure 3-26** and **Table 3-28**

The standard 15-pin female VGA connector connects to a CRT or LCD monitor.

PIN	DESCRIPTION	PIN			DESCRIPTION
1	RED	6	GROUND	11	NC
2	GREEN	7	GROUND	12	DDCDAT
3	BLUE	8	GROUND	13	HSYNC

4	NC	9	NC	14	VSYNC
5	GROUND	10	GROUND	15	DDCCLK

Table 3-28: VGA1 Connector Pinouts

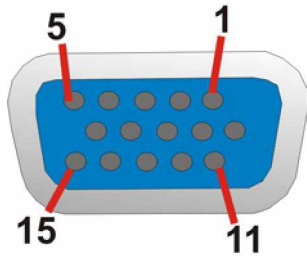

Figure 3-26: VGA1 Connector

Chapter

4

Installation and Configuration

4.1 Anti-static Precautions

Electrostatic discharge (ESD) can cause serious damage to electronic components, including the 3302040. (Dry climates are especially susceptible to ESD.) It is therefore critical that whenever the 3302040 (or any other electrical component) is handled, the following anti-static precautions are strictly adhered to.

- „ **Wear an anti-static wrist band:** - Wearing a simple anti-static wrist band can help to prevent ESD from damaging the board.
- „ **Self-grounding:**- Before handling the board touch any grounded conducting material. During the time the board is handled, frequently touch any conducting materials that are connected to the ground.

4.2 Installation Considerations



NOTE:

The following installation notices and installation considerations should be read and understood before the motherboard is installed. All installation notices pertaining to the installation of the motherboard should be strictly adhered to. Failing to adhere to these precautions may lead to severe damage of the motherboard and injury to the person installing the motherboard.

4.2.1 Installation Notices

Before and during the installation of the 3302040, please **do** the following:

- „ Read the user manual:
 - The user manual provides a complete description of the 3302040, installation instructions and configuration options.
- „ Wear an electrostatic discharge cuff (ESD):
 - Electronic components are easily damaged by ESD. Wearing an ESD cuff removes ESD from the body and helps prevent ESD damage.

3302040

- „ Place the motherboard on an antistatic pad:
 - When installing or configuring the motherboard, place it on an antistatic pad. This helps to prevent potential ESD damage.
- „ Turn off all power to the 3302040:
 - When working with the motherboard, make sure that it is disconnected from all power supplies and that no electricity is being fed into the system.

Before and during the installation of the 3302040 **DO NOT:**

- „ remove any of the stickers on the PCB board. These stickers are required for warranty validation.
- „ use the product before verifying all the cables and power connectors are properly connected.
- „ allow screws to come in contact with the PCB circuit, connector pins, or its components.

4.3 Unpacking



NOTE:

If any of the items listed below are missing when the 3302040 is unpacked, do not proceed with the installation and contact the 3302040 reseller or vendor.

4.3.1 Unpacking Precautions

Before installing the 3302040, unpack the motherboard. Some components on 3302040 are very sensitive to static electricity and can be damaged by a sudden rush of power. To protect it from being damaged, follow these precautions:

- „ The user should ground them self to remove any static charge before touching the 3302040. To do so wear a grounded wrist strap at all times or frequently touch any conducting materials that is connected to the ground.
- „ Handle the 3302040 by its edges. Do not touch the IC chips, leads or

circuitry if not necessary.

Do not place a PCB on top of an anti-static bag. Only the inside of the bag is safe from static discharge.

4.3.2 Checklist

When unpacking the 3302040, please make sure that the package contains the following items.

- „ 1 x 3302040 single board computer
- „ 1 x Mini jumper pack
- „ 1 x ATA 33 flat cable
- „ 1 x KB/MS Y cable
- „ 1 x RS-232 cable
- „ 1 x RS-232/422/485 cable
- „ 2 x SATA cable
- „ 1 x SATA power cable
- „ 1 x Utility CD
- „ 1 x Quick installation guide

If one or more of these items are missing, please contact the reseller or vendor the 3302040 was purchased from and do not proceed any further with the installation.

4.4 3302040 Motherboard Installation



WARNING!

Never run the motherboard without an appropriate heatsink and cooler that can be ordered from Global American, Inc or purchased separately.



WARNING!

Please note that the installation instructions described in this manual should be carefully followed in order to avoid damage to the motherboard components

and injury to the user.



WARNING!

When installing electronic components onto the motherboard always take the anti-static precautions listed above in order to prevent ESD damage to the motherboard and other electronic components like the CPU and DIMM modules

The following components must be installed onto the motherboard or connected to the motherboard during the installation process.

- „ DIMM modules
- „ Peripheral device connection

4.4.1 DIMM Module Installation

4.4.1.1 Purchasing the Memory Module

When purchasing SO-DIMM modules, the following considerations should be taken into account:

- „ The SO-DIMM socket can support a memory chip with a maximum size of 512MB
- „ The SO-DIMM socket supports SDRAM DIMM speeds of 266MHz

4.4.1.2 DIMM Module Installation

The 3302040 motherboard has two DDR SDRAM DIMM sockets. To install the DIMM modules, follow the instructions below.

Step 1: Locate the SO-DIMM module connector.

Step 2: Push the SO-DIMM chip into the socket at an angle. (See **Figure 4-1**)

Step 3: Gently pull the arms of the SO-DIMM socket out and push the rear of the SO-DIMM module down. (See **Figure 4-1**)

Step 4: Release the arms on the SO-DIMM socket. They clip into place and secure the SO-DIMM module in the socket.

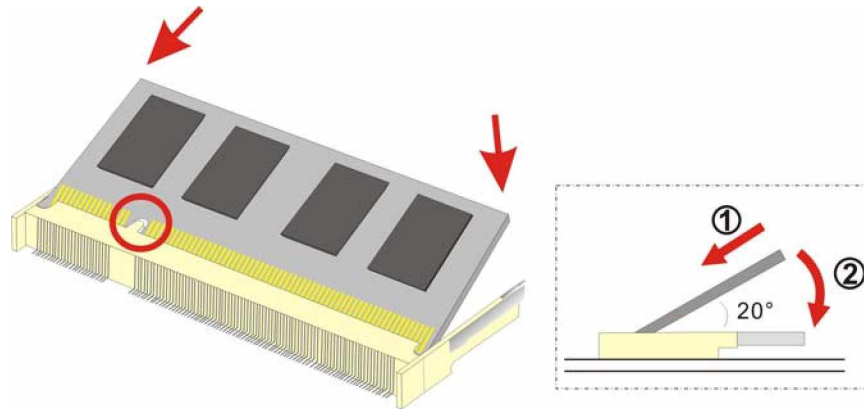

Figure 4-1: SO-DIMM Module Installation

4.5 Jumper Settings



NOTE:

A jumper is a metal bridge that is used to close an electrical circuit. It consists of two metal pins and a small metal clip (often protected by a plastic cover) that slides over the pins to connect them. To CLOSE/SHORT a jumper means connecting the pins of the jumper with the plastic clip and to OPEN a jumper means removing the plastic clip from a jumper.

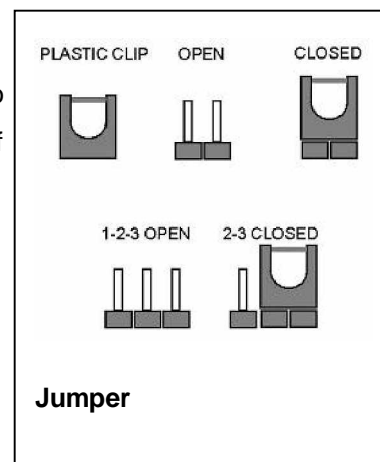

Before the 3302040 is installed in the system, the jumpers must be set in accordance with the desired configuration. The 3302040 motherboard has three on-board jumpers.

Description	Label	Type
-------------	-------	------

3302040

Clear CMOS	CN7	2-pin wafer
RS-422/485 select	JP2	3-pin header
COM1/2 Port RI and Voltage Selection (optional)	JP3	10-pin header
LCD panel voltage select	JP4	3-pin header
CRT/LCD Mode Select	JP5	3-pin header

Table 4-1: Jumpers

4.5.1 Clear CMOS Jumper



NOTE:

The battery connector (CN7) is used as the clear CMOS jumper on the 3302040.

Jumper Label:	CN7
Jumper Type:	2-pin header
Jumper Settings:	See Figure 4-2
Jumper Location:	See Table 4-2

If the 3302040 fails to boot due to improper BIOS settings, use this connector to clear the CMOS data and reset the system BIOS information. To do this, disconnect CN7 and keep it disconnected for at least five seconds. After five seconds has elapsed, reinsert the connector.

If the “CMOS Settings Wrong” message is displayed during the boot up process, the fault may be corrected by pressing the F1 to enter the CMOS Setup menu. Do one of the following:

- „ Enter the correct CMOS setting

- „ Load Optimal Defaults
- „ Load Failsafe Defaults.

After having done one of the above, save the changes and exit the CMOS Setup menu.

	DESCRIPTION
Closed	Keep CMOS Setup
Open	Clear CMOS Setup

Table 4-2: Clear CMOS Jumper Settings

The location of the clear CMOS connector is shown in **Figure 4-2** below.

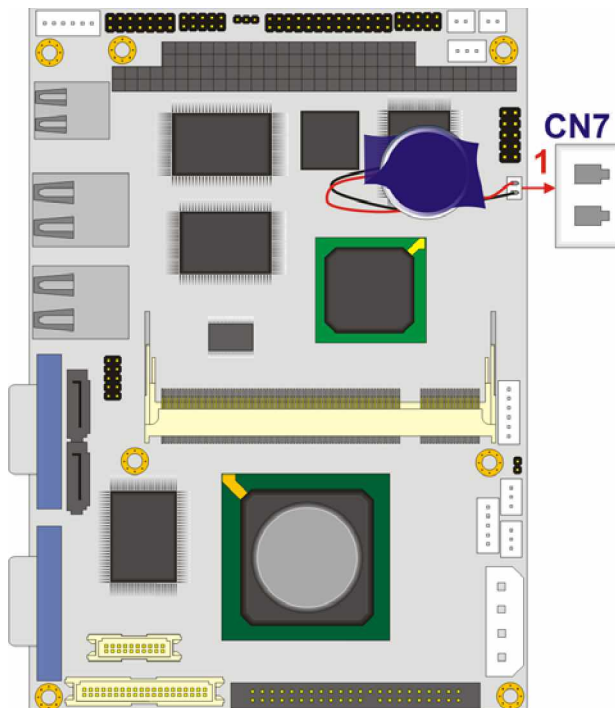

Figure 4-2: Clear CMOS Connector

4.5.2 AT Power Select Jumper Settings

Jumper Label:	JP1
Jumper Type:	2-pin header
Jumper Settings:	See Table 4-3
Jumper Location:	See Figure 4-3

The AT/ATX Power Mode Select jumper specifies the systems power mode. Jumper settings are shown in **Table 4-3**.

AT Power Select	Description	
Short	Use AT power	Default
Open	Use ATX power	

Table 4-3: AT Power Select Jumper Settings

The location of the clear CMOS connector is shown in **Figure 4-3** below.

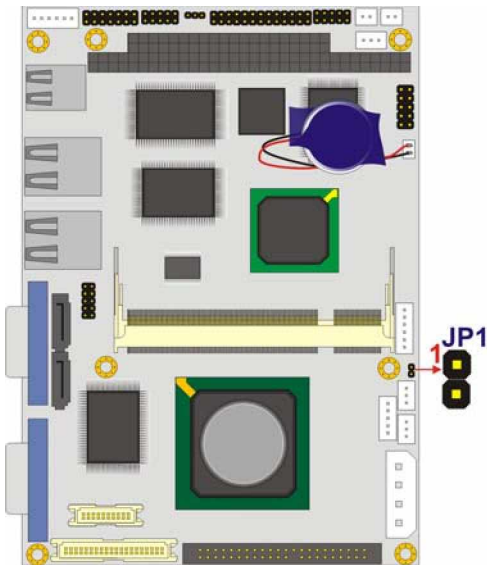

Figure 4-3: AT/ATX Mode Select Jumper

4.5.3 RS-422/485 Serial Port Select

Jumper Label:	JP2
Jumper Type:	3-pin header
Jumper Settings:	See Table 4-4
Jumper Location:	See Figure 4-4

This jumper configures the serial port connector as an RS-422 serial port or as an RS-485 serial port. The selection options are shown in **Table 4-4**.

	DESCRIPTION
Short 1 – 2	RS-422
Short 2 – 3 (Default)	RS-485

Table 4-4: Serial Port Mode Select Jumper Settings

The serial port setup jumper location is shown in **Figure 4-4** below.

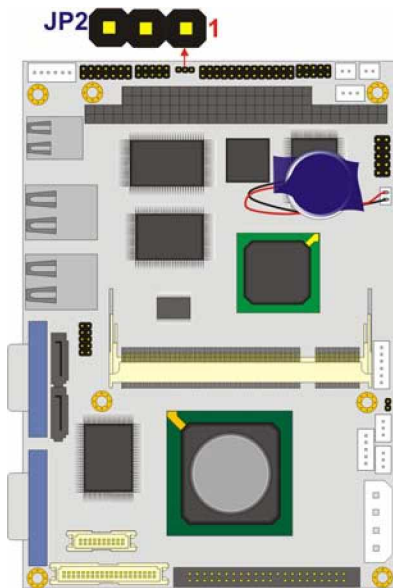

Figure 4-4: Serial Port Mode Select Jumper Pinout Locations

4.5.4 COM 1/2 Port RI and Voltage Select (OPTIONAL)

Jumper Label:	JP3
Jumper Type:	10-pin header
Jumper Settings:	See Table 4-5
Jumper Location:	See Figure 4-5

This jumper configures the RI pin for both the COM 1 serial port and the COM 2 serial port.

The selection options are shown in **Table 4-5**.

	DESCRIPTION
Short 1 – 3	COM 1 RI Pin use +12V
Short 3 – 5	COM 1 RI Pin use +5V
Short 7 – 9 (Default)	COM 1 RI Pin use RI
Short 2 – 4	COM 2 RI Pin use +12V
Short 4 – 6	COM 2 RI Pin use +5V
Short 8 – 10 (Default)	COM 2 RI Pin use RI

Table 4-5: COM 1/2 Port RI and Voltage Select Jumper Settings

The serial port setup jumper location is shown in **Figure 4-5** below.

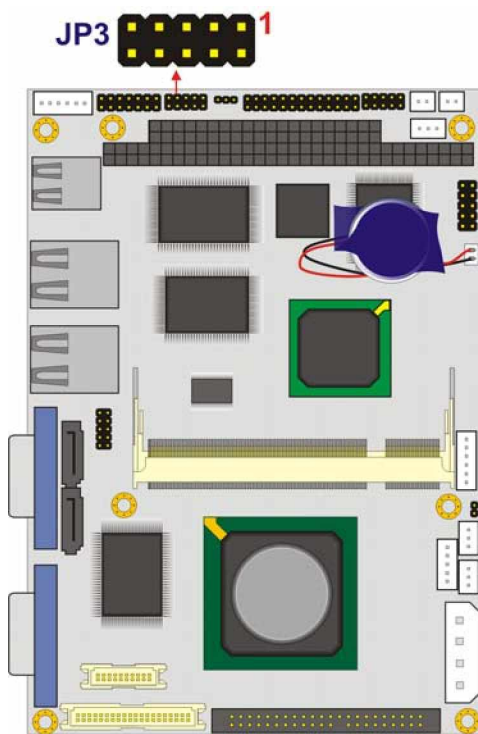

Figure 4-5: COM 1/2 Port RI and Voltage Select Jumper Pinout Locations

4.5.5 LCD Voltage Selection



WARNING

Permanent damage to the screen and 3302040 may occur if the wrong voltage is selected with this jumper. Please refer to the user guide that came with the monitor to select the correct voltage.

Jumper Label:	JP4
Jumper Type:	3-pin header
Jumper Settings:	See Table 4-6
Jumper Location:	See Figure 4-6

The **JP4** jumper allows the LVDS screen voltage to be set.

	DESCRIPTION
Short 1-2 (Default)	+ 3.3V LVDS
Short 2-3	+5V LVDS

Table 4-6: LVDS Voltage Selection Jumper Settings

The LVDS Voltage Selection jumper location is shown in **Figure 4-6**.

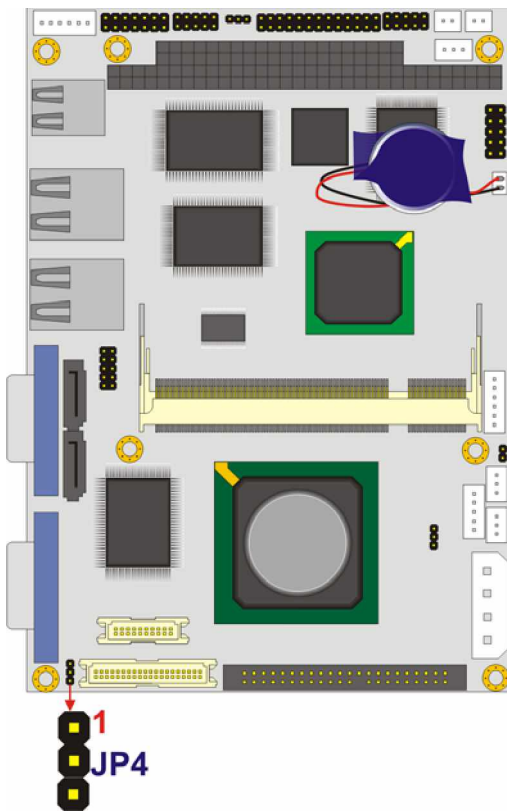

Figure 4-6: LVDS Voltage Selection Jumper Pinout Locations

4.5.6 CRT/LCD Mode Selection

- Jumper Label: **JP5**
- Jumper Type: 3-pin header
- Jumper Settings: See **Figure 4-7**

Jumper Location: See **Table 4-7**

The CRT/LCD mode select jumper allows the video mode of the motherboard to be selected.

	DESCRIPTION
1-2	LCD MODE
2-3 (Default)	DE

Table 4-7: CRT/LCD Mode Selection Jumper Settings

The LVDS Voltage Selection jumper location is shown in **Figure 4-7**.

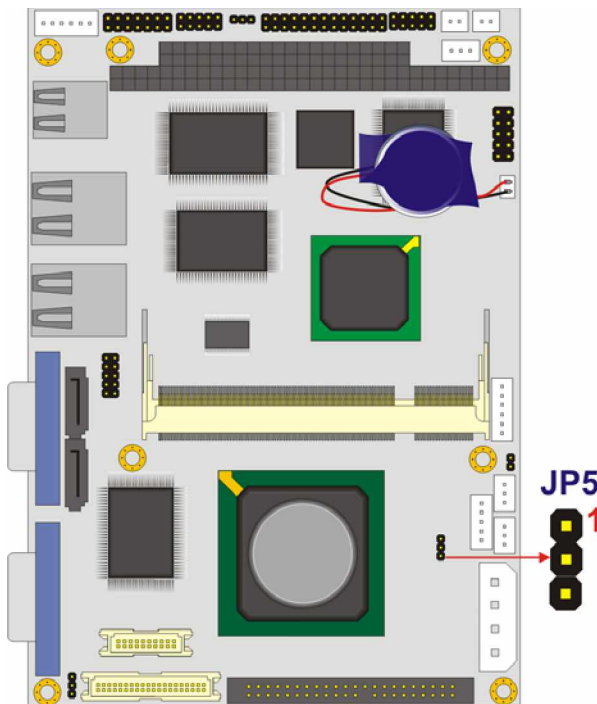

Figure 4-7: CRT/LCD Mode Selection Jumper Settings

4.6 Chassis Installation

Cables provided by Global American, Inc that connect peripheral devices to the 3302040 are listed in

Table 4-8. Cables not included in the kit must be separately purchased.

3302040

Quantity	
1	ATA 33 flat cable
1	RS-232/422/485 cable
2	SATA drive cable
1	SATA drive power cable
1	KB/MS Y cable

Table 4-8: Global American, Inc Provided Cables

To install the 3302040 into a chassis, please follow the steps below.

- Step 1:** Select a chassis
- Step 2:** Install the CompactFlash card (optional)
- Step 3:** Install the RS-232/422/485 cable (optional)
- Step 4:** Connect the 3302040 to the hard disks (optional)
- Step 5:** Connect the 3302040 to the SATA drives
- Step 6:** Connect other internal peripheral devices

4.6.1 Chassis selection

The chassis selected must be able to support a half-size CPU PCI card. Global American, Inc has many available options. Please visit the Global American, Inc website (www.globalamericaninc.com) or contact an Global American, Inc sales representative for more details.

4.6.2 Install the CompactFlash card

To install the a CF card (Type 1 or Type 2) onto the 3302040, please follow the steps below:

- Step 1:** Place the CPU card on an anti-static pad with the solder side facing up.
- Step 2:** Locate the CF socket.
- Step 3:** Make sure the CF card is properly aligned with the CF socket.
- Step 4:** Gently insert the CF card into the socket making sure the socket pins are properly inserted into the socket (**Figure 4-8**).

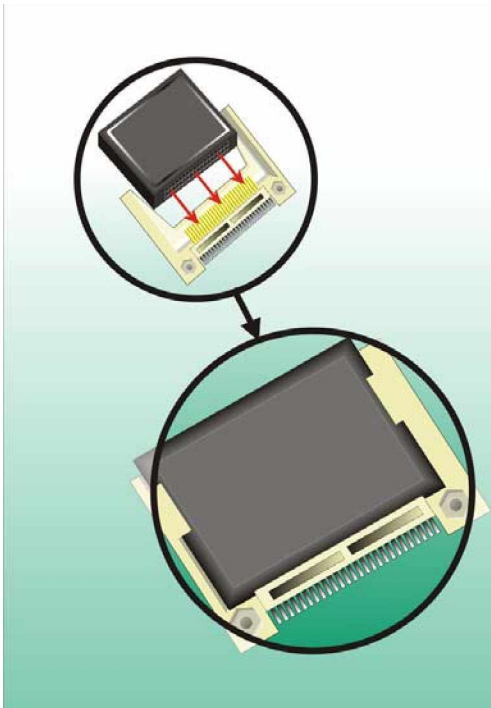

Figure 4-8: CompactFlash Card Installation

4.6.3 Install the RS-232/422/485 Cable

The 3302040 is shipped with a RS-232/422/485 cable. To install the RS-232 cable please follow the steps below.

- Step 1:** Locate the COM2 serial port connector.
- Step 2:** Insert the small connector on the cable into the serial port box headers on the 3302040.

4.6.4 IDE Disk Drive Connector

The 3302040 is shipped with an ATA 33 flat cable. The cable is connected to the 3302040 and to one or two IDE HDD. To connect an IDE HDD to the 3302040, follow the instructions below.

Step 1: Find the ATA 33 flat cable in the kit that came with the motherboard.

Step 2: Locate the IDE connector on the motherboard.

Step 3: Connect one of the connectors two the connector on the board and the other two connectors to a hard-drive.

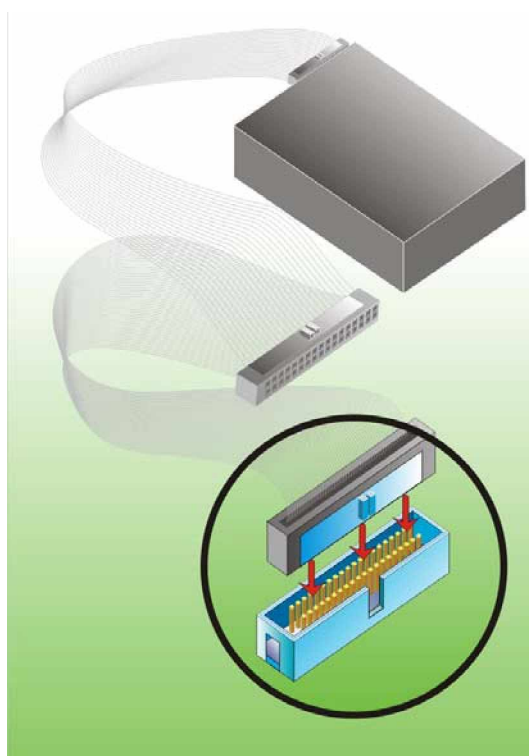

Figure 4-9: IDE Cable Connection

Step 4: Locate the red wire on the other side of the cable that corresponds to the pin 1 connector.

Step 5: Connect the other side of the cable to the HDD making sure that the pin 1 cable corresponds to pin 1 on the connector

4.6.5 SATA Drive Connection

The 3302040 has four onboard 150Mb/s SATA drive connectors. The 3302040 is shipped with two SATA drive cables and one SATA drive power cable. To connect the SATA drives to the connectors, please follow the steps below.

Step 1: Locate the SATA drive connector on the board.

Step 2: Press the clip on the connector at the end of the SATA cable and insert the cable connector into the onboard SATA drive connector (**Figure 4-10**).

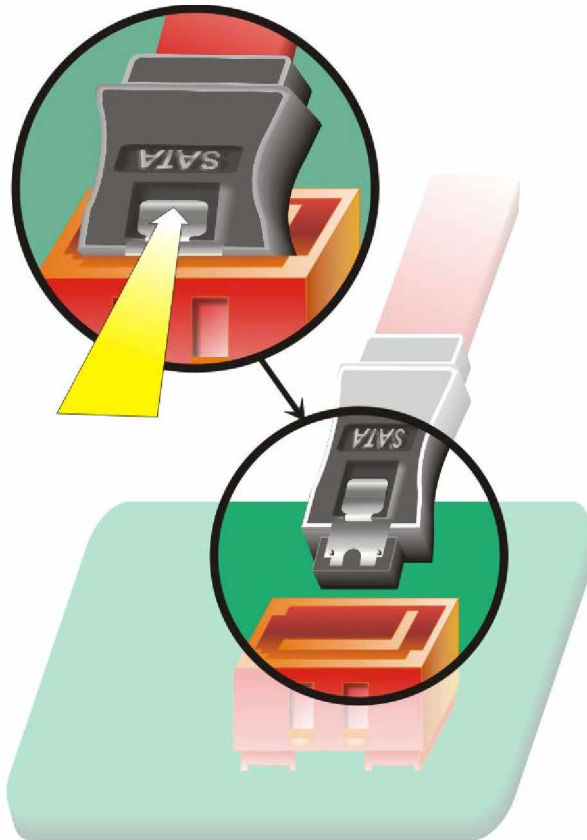

Figure 4-10: SATA Drive Cable Connection

Step 3: Connect the connector on the other end of the cable to the connector at the back

of the SATA drive (**Figure 4-11**).

Step 4: Connect the SATA power connector to the back of the SATA drive (**Figure 4-11**).

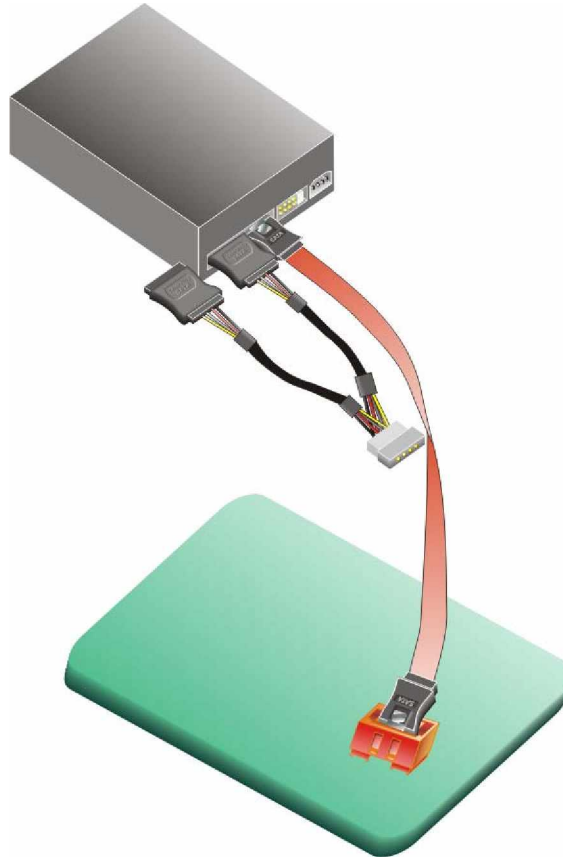

Figure 4-11: SATA Drive Connection

4.7 Rear Panel Connectors

4.7.1 LCD Panel Connection

The conventional CRT monitor connector, VGA1, is a 15-pin, female D-SUB connector. Pin assignments can be seen in that can be connected to external monitors.

4.7.2 Ethernet Connection

The rear panel RJ-45 connectors can be connected to an external LAN and communicate with data transfer rates up to 1Gb/s.

4.7.3 USB Connection

The rear panel USB connectors provide easier and quicker access to external USB devices. The rear panel USB connector is a standard connector and can easily be connected to other USB devices.

4.7.4 Keyboard and Mouse Connection

A PS/2 keyboard and a PS/2 mouse can be connected to the appropriate PS/2 connector on the rear panel.

Chapter

5

AWARD BIOS Setup

5.1 Introduction

A licensed copy of Phoenix Award BIOS is preprogrammed into the ROM BIOS. The BIOS setup program allows users to modify the basic system configuration. This chapter describes how to access the BIOS setup program and the configuration options that may be changed.

5.1.1 Starting Setup

The Phoenix Award BIOS is activated when the computer is turned on. The setup program can be activated in one of two ways.

1. Press the **DELETE** key as soon as the system is turned on or
2. Press the **DELETE** key when the “**Press Del to enter SETUP**” message appears on the screen.

If the message disappears, restart the computer and try again.

5.1.2 Using Setup

Use the arrow keys to highlight items, press **ENTER** to select, use the **PAGEUP** and **PAGEDOWN** keys to change entries, press **F1** for help and press **ESC** to quit. Navigation keys are shown below.

Key	Function
Up arrow	Move to the item above
Down arrow	Move to the item below
Left arrow	Move to the item on the left hand side
Right arrow	Move to the item on the right hand side
+ / Page up	Increase the numeric value or make changes
- / Page down	Decrease the numeric value or make changes
Esc	Main Menu – Quit and do not save changes into CMOS Status Page Setup Menu and Option Page Setup Menu -- Exit current page and return to Main Menu

F1	General help, only for Status Page Setup Menu and Option Page Setup Menu
F2	Item help
F5	Previous values for the page menu items
F6	Fail-safe defaults for the current page menu items
F7	Optimized defaults for the current page menu items
F9	Menu in BIOS
F10	Save changes and Exit BIOS

Table 5-1: BIOS Navigation Keys

5.1.3 Getting Help

When **F1** is pressed a small help window describing the appropriate keys to use and the possible selections for the highlighted item appears. To exit the Help Window press **Esc** or the **F1** key again.

5.1.4 Unable to Reboot After Configuration Changes

If the system cannot be booted after changes are made, restore the CMOS defaults. The CPU card should come with a restore CMOS settings jumper. Refer to **Section ??** for more information.

5.1.5 Main BIOS Menu

Once the BIOS opens, the **Main Menu (BIOS Menu 1)** appears.

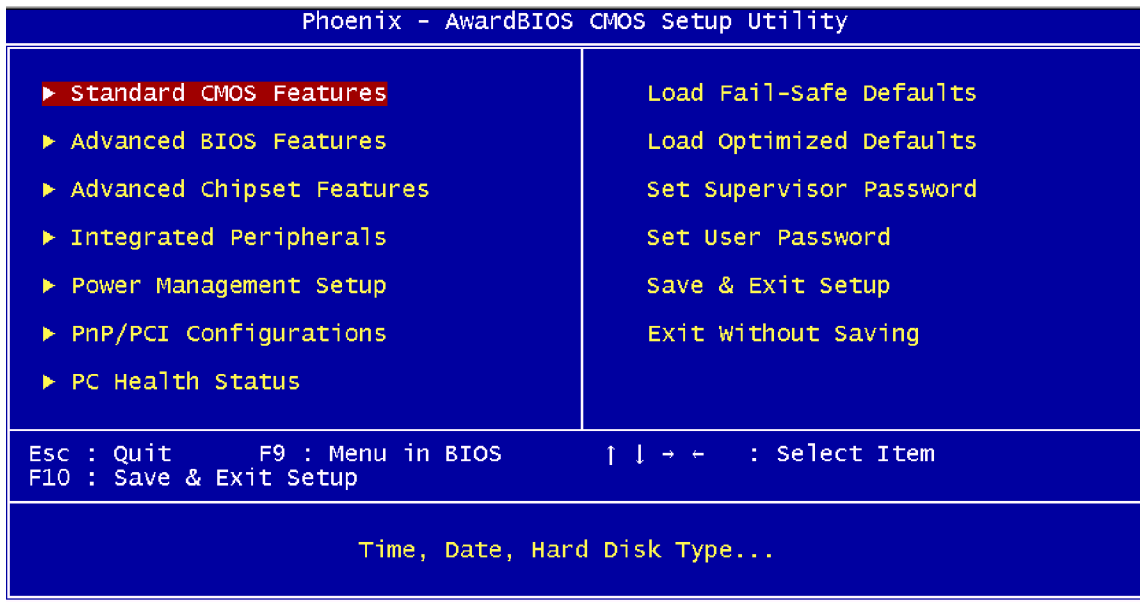

BIOS Menu 1: Award BIOS CMOS Setup Utility



NOTE:

The following sections will completely describe the menus listed below and the configuration options available to users.

The following menu options are seen in **BIOS** Menu 1.

- „ **Standard CMOS Features:** Changes the basic system configuration.
- „ **Advanced BIOS Features:** Changes the advanced system settings.
- „ **Advanced Chipset Features:** Changes the chipset configuration features.
- „ **Integrated Peripherals:** Changes the settings for integrated peripherals.
- „ **Power Management Setup:** Configures power saving options.
- „ **PnP/PCI Configurations:** Changes the advanced PCI/PnP settings.
- „ **PC Health Status:** Monitors essential system parameters.

The following user configurable options are also available in **BIOS Menu 1:**

⏪ Load Fail-Safe Defaults

Use the **Load Fail-Safe Defaults** option to load failsafe default values for each BIOS parameter in the setup menus. Press **F6** for this operation on any page.

Load Optimized Defaults

Use the **Load Optimized Defaults** option to load optimal default values for each BIOS parameter in the setup menus. Press **F7** for this operation on any page.

Set Supervisor Password

Use the **Set Supervisor Password** option to set the supervisor password. By default, no supervisor password is set. To install a supervisor password, select this field and enter the password. After this option is selected, a red dialogue box appears with “**Enter Password:**”. Type the password and press **ENTER**. Retype the original password into the “**Confirm Password:**” dialogue box and press **ENTER**. To disable the password, simply press **ENTER** in the “**Enter Password:**” dialogue box, then press any key in the “**Password Disabled !!!**” dialogue box.

Set User Password

Use the **Set User Password** option to set the supervisor password. By default no user password is set. To install a user password, select this field and enter the password. After this option is selected, a red dialogue box appears with “**Enter Password:**”. Type the password and press **ENTER**. Retype the original password into the “**Confirm Password:**” dialogue box and press **ENTER**. To disable the password, simply press **ENTER** in the “**Enter Password:**” dialogue box, then press any key in the “**Password Disabled !!!**” dialogue box.

Save & Exit Setup

Use the **Save & Exit Setup** option to save any configuration changes made and exit the BIOS menus.

Exit Without Saving

Use the **Exit Without Saving** option to exit the BIOS menus without saving any configuration changes.

5.2 Standard CMOS Features

Use the **Standard CMOS Features** BIOS menu (**BIOS Menu 2**) to set basic BIOS configuration options.

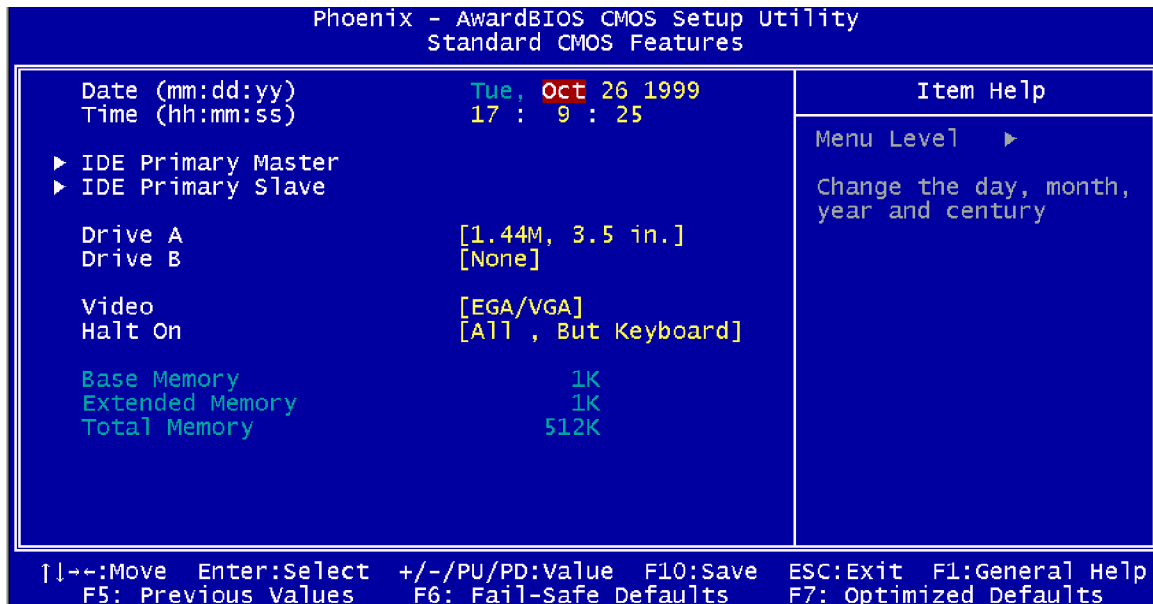

BIOS Menu 2: Standard CMOS Features

📅 Date [Day mm:dd:yyyy]

Use the **Date** option to set the system date

🕒 Time [hh/mm/ss]

Use the **Time** option to set the system time.

📁 IDE Master and IDE Slave

When entering setup, BIOS auto detects the presence of IDE devices. The **Standard CMOS Features** menu shows the status of the auto detected IDE devices. The following IDE devices are detected and shown in the **Standard CMOS Features** menu:

3302040

- „ IDE Primary Master
- „ IDE Primary Slave
- „ IDE Secondary Master
- „ IDE Secondary Slave

IDE device configurations are changed or set in the IDE Configuration menu (**BIOS Menu 3**). If an IDE device is detected, and one of the above listed two BIOS configuration options is selected, the IDE configuration options shown in **Section 5.2.1** appear.

Drive A/B [None]

Use the **Drive A/B** configuration to specify the floppy drive type installed in the system. The floppy drive configuration options are:

- „ None
- „ 360K, 5.25 in.
- „ 1.2M, 5.25 in.
- „ 720K, 3.5 in.
- „ 1.44M, 3.5in (Default)
- „ 2.88M, 3.5 in.

Video

Use the **Video** option to select the CRT screen type the system connects to. The video configuration options are:

- „ EGA/VGA (Default)
- „ CGA 40
- „ CGA 80
- „ MONO

Halt On [All, But Keyboard]

Use the **Halt On** option to specify what errors detected during the power up process stop the system.

↑	All Errors		Whenever BIOS detects a non-fatal error the system is stopped and the user prompted.
↑	No Errors		The system boot is not stopped for any errors that may be detected.
↑	All, But Keyboard	(Default)	The system boot does not stop for a keyboard error; it stops for all other errors.
↑	All, But Diskette		The system boot does not stop for a disk error; it stops for all other errors.
↑	All, But Disk/Key		The system boot does not stop for a keyboard or a disk error; it stops for all other errors.

↑ **Base Memory:**

The **Base Memory** is NOT user configurable. The POST determines the amount of base (or conventional) memory installed in the system. The value of the base memory is typically 512K for systems with 512K memory installed, or 640K for systems with 640K or more memory installed.

↑ **Extended Memory**

The **Extended Memory** is NOT user configurable. The BIOS determines how much extended memory is present during the POST. This is the amount of memory above 1MB located in the memory address map of the CPU.

↑ **Total Memory**

The **Total Memory** is NOT user configurable.

5.2.1 IDE Primary Master/Slave

Use the **IDE Primary Master/Slave** menu (**BIOS Menu 3**) to set or change the master/slave IDE configurations.

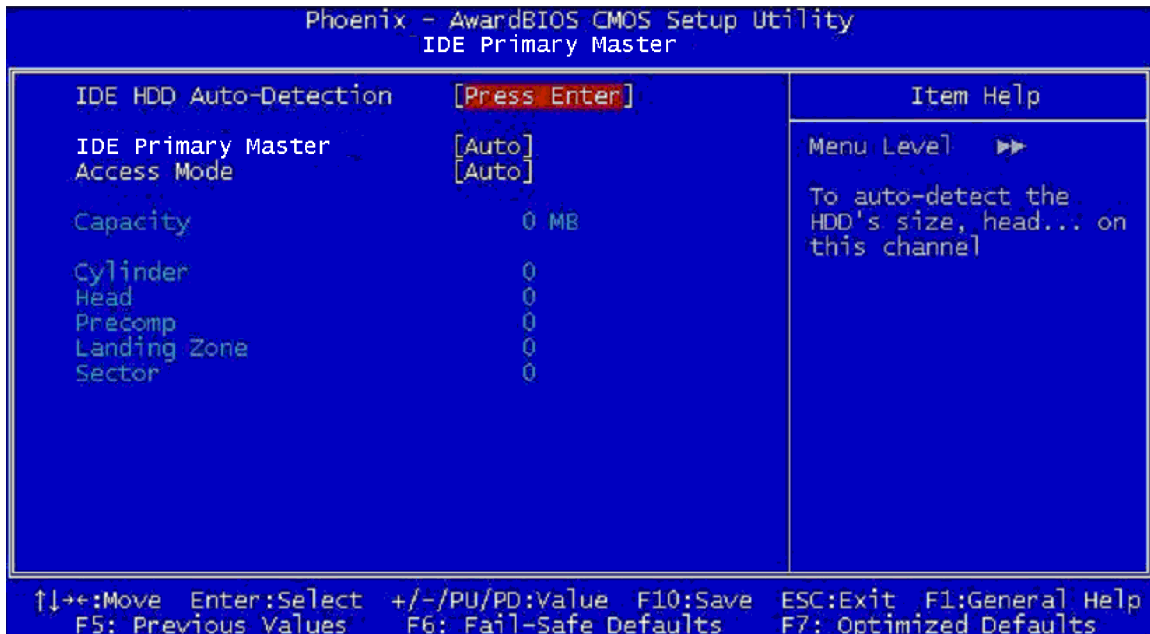

BIOS Menu 3: IDE Channel Master

⌄ IDE HDD Auto-Detection [Press Enter]

Use the **IDE HDD Auto-Detection** option to enable BIOS to automatically detect the IDE settings. Select **IDE HDD Auto-Detection** and press **ENTER**. BIOS automatically detects the HDD type. Do not set this option manually.

⌄ IDE Primary Master [Auto]

Use the **IDE Primary Master** option to activate or deactivate the following drive channels:

- „ Channel 0 Master
- „ Channel 0 Slave

- „ Channel 1 Master
- „ Channel 0 Slave

 **None** If no drives are connected to the IDE channel select this option. Once set, this IDE channel becomes inaccessible and any drives attached to it are undetected.

 **Auto** (Default) Setting this option allows the device to be automatically detected by the BIOS.

 **Manual** Selecting this option allows manual configuration of the device on the IDE channel in BIOS.

Access Mode [Auto]

The **Access Mode** option can only be configured if the BIOS configuration option is set to either **Manual** or **Auto**.. Use the **Access Mode** option to determine the hard disk BIOS translation modes. Most systems now use hard drives with large capacities and therefore either the LBA translation mode or auto mode should be selected.

 **CHS** Select this mode if the HDD capacity is less than 504MB.

 **LBA** Select this mode if the HDD capacity is more than 8.4GB.

 **Large** This mode is an extended ECHS mode and while it supports HDDs larger than 504MB, it is not recommended.

 **Auto** (Default) If you are unsure of what access mode to set, select this option.

Capacity

3302040

The **Capacity** specification indicates the storage capacity of the HDD installed in the system.

↑ **Cylinder**

The **Cylinder** specification indicates how many cylinders (tracks) are on the HDD installed in the system.

↑ **Head**

The **Head** specification indicates how many logical heads are on the HDD installed in the system.

↑ **Precomp**

The **Precomp** specification indicates on what track the write precompensation begins.

↑ **Landing Zone**

The **Landing Zone** specification indicates where the disk head will park itself after the system powers off.

↑ **Sector**

The **Sector** specification indicates how many logical sectors the HDD has been divided into.

5.3 Advanced BIOS Features

Use the **Advanced BIOS Features** menu (**BIOS Menu 4**) to configure the CPU and peripheral device configuration options.

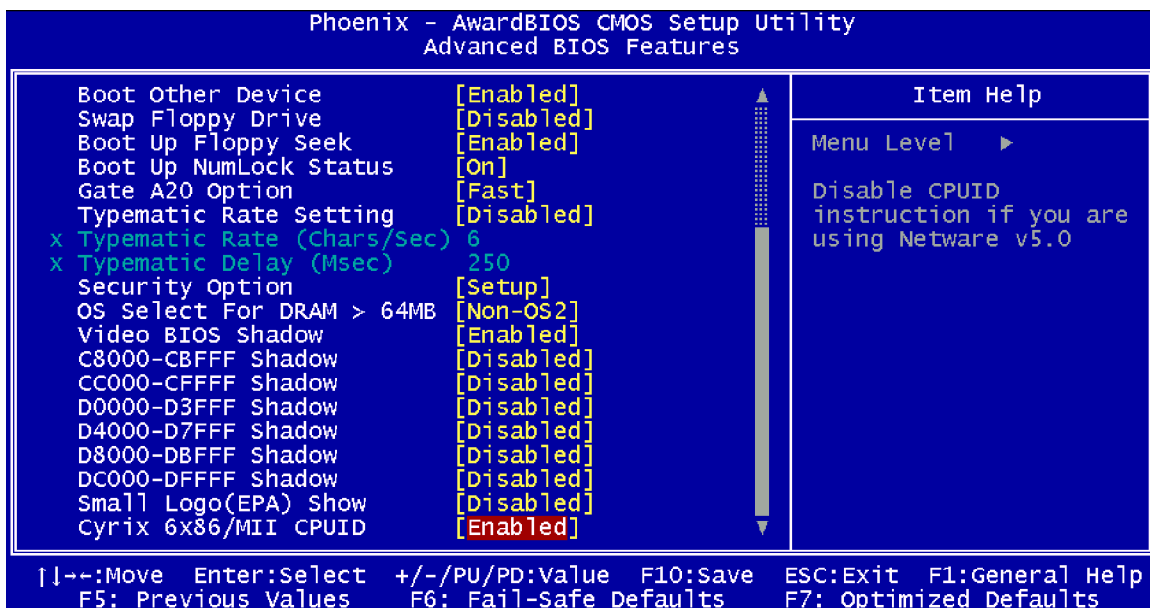
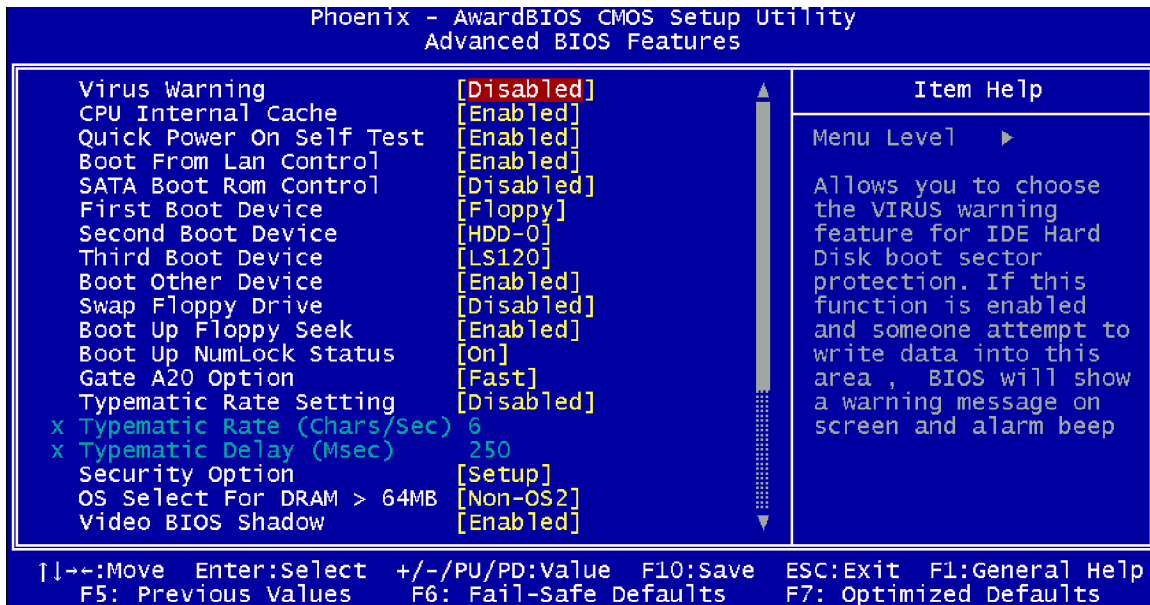

BIOS Menu 4: Advanced BIOS Features

↑ Virus Warning [Disabled]



NOTE:

Many disk diagnostic programs can cause the above warning message to

appear when the program attempts to access the boot sector table. If you are running such a program, it is recommended that the virus protection function be disabled beforehand.

Use the **Virus Warning** option to enable BIOS to monitor the boot sector and partition table of the HDD for any attempted modification. If a modification attempt is made, the BIOS halts the system and an error message appears. If necessary, an anti-virus program can then be run to locate and remove the virus before any damage is done.

- ↑ **Enabled** Activates automatically when the system boots up causing a warning message to appear when anything attempts to access the boot sector or HDD partition table.
- ↑ **Disabled** (Default) No warning message appears when there is an attempt to access the boot sector or HDD partition table.

↑ **CPU Internal Cache [Enabled]**

Use the **CPU Internal Cache** option to enable or disable the internal CPU cache.

- ↑ **Disabled** The internal CPU cache is disabled.
- ↑ **Enabled** (Default) The internal CPU cache is enabled.



↑ **Quick Power On Self Test [Enabled]**

Use the **Quick Power On Self Test** option to speed up the POST after the computer is turned on. If enabled, BIOS shortens or skips some POST check items.

- ↑ **Disabled** Normal POST occurs after the computer is turned on.
- ↑ **Enabled** (Default) Quick POST occurs after the computer is turned on.



↑ **Boot From LAN Control [Disabled]**

Use the **BOOT From LAN Control** option to enable the system to be booted from a remote system.

- 
Disabled (Default) The system cannot be booted from a remote system through the LAN.
- 
Enabled The system can be booted from a remote system through the LAN.

SATA Boot ROM Control [Disabled]

Use the **SATA Boot ROM Control** option to configure SATA IDE use in DOS mode.

- 
Disabled (Default) Disables SATA IDE use in DOS mode.
- 
Enabled Enables SATA IDE use in DOS mode.

Boot Device

Use the **Boot Device** options to select the order of the devices the system boots from.

There are three boot device configuration options:

- „ **First Boot Device** [Default: HDD-0]
- „ **Second Boot Device** [Default: CDROM]
- „ **Third Boot Device** [Default: SCSI]

Using the default values, the system first looks for a HDD to boot from. If it cannot find an HDD, it boots from a CD-ROM. If both The HDD and the CD-ROM are unavailable, the system boots from a SCSI drive.



Boot Device configuration options are:

- „ Floppy
- „ LS120
- „ HDD-0
- „ SCSI
- „ CDROM

- ” HDD-1
- ” HDD-2
- ” HDD-3
- ” ZIP100
- ” USB-FDD
- ” USB-ZIP
- ” USB-CDROM
- ” USB-HDD
- ” LAN
- ” Disabled



Boot Other Device [Enabled]

Use the **Boot Other Device** option to determine whether the system uses a second or third boot device if the first boot device is not found.

-  **Disabled** The system does not look for second and third boot devices if the first one is not found.
-  **Enabled** (Default) The system looks for second and third boot devices if the first one is not found.

Swap Floppy Drive [Disabled]

Use the **Swap Floppy Drive** option to designate drive A as drive B and drive B as drive A.

-  **Disabled** (Default) Cannot designate A or B to a floppy drive without changing the physical connection
-  **Enabled** Can designate A or B to a floppy drive without changing the physical connection

Boot Up Floppy Seek [Disabled]

Use the **Boot Up Floppy Seek** option to enable the BIOS to determine if the floppy disk drive installed has 40 or 80 tracks during the POST. 360K FDDs have 40 tracks while 760K, 1.2M and 1.44M FDDs all have 80 tracks.

 **Disabled** (Default) BIOS does not search for the type of FDD drive by track number. Note that there is no warning message if the drive installed is 360K.

 **Enabled** BIOS searches for a FDD to determine if it has 40 or 80 tracks. Note that BIOS cannot tell the difference between 720K, 1.2M or 1.44M drives as they all have 80 tracks.

Boot Up Numlock Status [On]

Use the **Boot Up Numlock Status** option to specify the default state of the numeric keypad.

 **Off** The keys on the keypad are not activated.

 **On** (Default) Activates the keys on the keypad.

Gate A20 Option [Fast]

Use the **Gate A20 Option** option to set if the keyboard controller or the chipset controls the Gate A20 switching.

 **Normal** The keyboard controller does the switching.

 **Fast** (Default) The chipset does the switching.

Typematic Rate Setting [Disabled]

Use the **Typematic Rate Setting** configuration option to specify if only one character is allowed to appear on the screen if a key is continuously held down. When this option is enabled, the BIOS reports as before, but it then waits a moment, and, if the key is still held

3302040

down, it begins to report that the key has been pressed repeatedly. This feature accelerates cursor movement with the arrow keys.

 **Disabled** (Default) Disables the typematic rate.

 **Enabled** Enables the typematic rate.

Typematic Rate (Chars/sec) [6]

The **Typematic Rate** option can only be configured if the **Typematic Rate Setting** is enabled. Use the **Typematic Rate** option to specify the rate keys are accelerated.

 **6** (Default) 6 characters per second

 **8** 8 characters per second

 **10** 10 characters per second

 **12** 12 characters per second

 **15** 15 characters per second

 **20** 20 characters per second

 **24** 24 characters per second

 **30** 30 characters per second

Typematic Delay (Msec) [250]

The **Typematic Rate** option can only be configured if the **Typematic Rate Setting** is enabled. Use the **Typematic Delay** option to specify the delay time between when a key is first pressed and when the acceleration begins.

 **250** (Default) 250 milliseconds

 **500** 500 milliseconds

 **750** 750 milliseconds

 **1000** 1000 milliseconds

Security Option [Setup]

Use the **Security Option** to limit access to both the system and Setup, or just Setup.

 **Setup** (Default) The system does not boot and access to Setup is denied if the correct password is not entered at the prompt.

 **System** The system boots, but access to Setup is denied if the correct password is not entered at the prompt.





NOTE:

To disable security, select the password setting in the Main Menu. When asked to enter a password, don't type anything, press **ENTER** and the security is disabled. Once the security is disabled, the system boots and Setup can be accessed.

OS Select For DRAM > 64MB [Non-OS2]

Use the **OS Select For DRAM > 64MB** option to specify the operating system.

 **Enabled** Specifies the operating system used as OS/2.

 **Disabled** (Default) Select this option when not using the OS/2 operating system.

Video BIOS Shadow [Enabled]

Use the **Video Bios Shadow** option to enable video BIOS to be copied to RAM.

 **Disabled** Video BIOS is not copied to RAM.

3302040

 **Enabled** (Default) Video BIOS is copied to RAM.

XXXXX-YYYYY Shadow [Disabled]

Use the **XXXXX-YYYYY Shadow** option to write the contents of the ROM area XXXXX-YYYYY to the same address in the system RAM.

 **Disabled** (Default) Contents from ROM area XXXXX-YYYYY are not written to the RAM.

 **Enabled** Contents from ROM area XXXXX-YYYYY are written to the RAM.

Small Logo (EPA) Show [Disabled]

Use the **Small Logo (EPA) Show** option to specify if the Environmental Protection Agency (EPA) logo appears during the system boot-up process. If enabled, the boot up process may be delayed.

 **Disabled** (Default) EPA logo does not appear during boot up.

 **Enabled** EPA logo appears during boot up.

Cyrix 6x86/MII CPUID [Enabled]

Use the **Cyrix 6x86/MII CPUID** option to determine if the system checks to see if a Cyrix CPU is installed.

 **Disabled** (Default) The system doesn't look for a Cyrix CPU.

 **Enabled** The system looks for a Cyrix CPU.

5.4 Advanced Chipset Features

Use the **Advanced Chipset Features** menu (**BIOS Menu 5**) to change chipset configuration options.

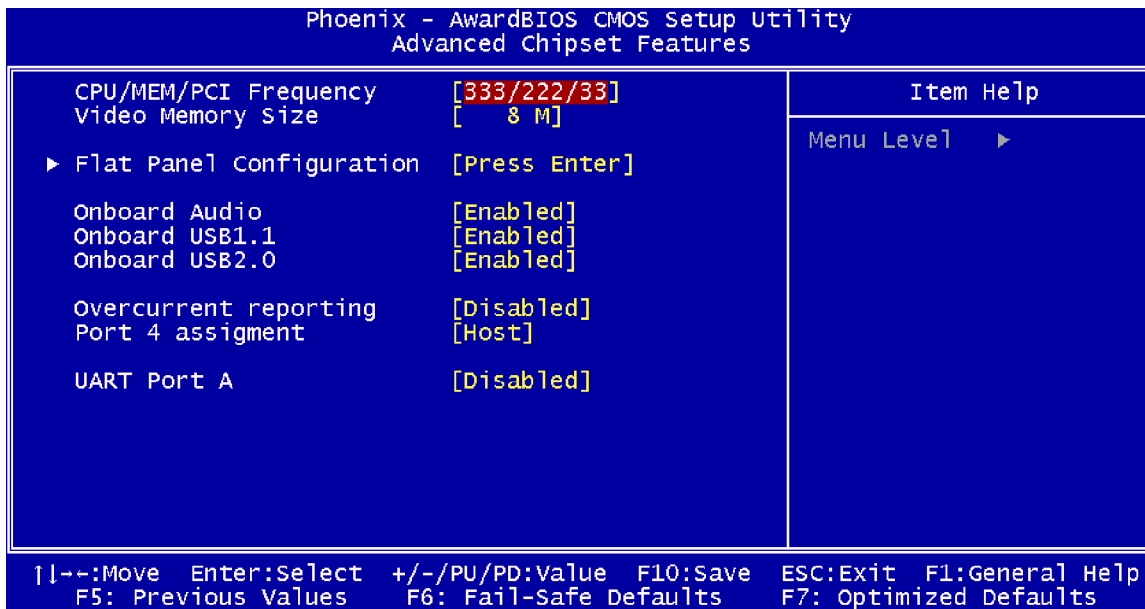

BIOS Menu 5: Advanced Chipset Features

⏪ CPU Frequency [200/133/33]

Use the **CPU Frequency** option to set the CPU frequency. The **CPU Frequency** options are:

- „ 200/33/33 (Default)
- „ 333/222/33

⏪ Video Memory Size [8M]

Use the **Video Memory Size** option to determine how much memory is allocated to the video graphics device. The **Video Memory Size** options are:

- „ None
- „ 4M
- „ 6M
- „ 8M (Default)
- „ 12M
- „ 16M

⏮ **Flat Panel Configuration [Press Enter]**

Use the **Flat Panel Configuration** option to open the **Flat Panel Configuration** menu.
The **Flat Panel Configuration** options are shown in **Section 5.4.1**.

⏮ **OnBoard Audio [Enabled]**

Use the **OnBoard Audio** option to enable or disable the onboard codec.

⏮ **Disabled** The onboard codec is disabled.

⏮ **Enabled** (Default) The onboard codec is detected and enabled.

⏮ **Onboard USB1.1 [Enabled]**

Use the **Onboard USB1.1** option to enable or disable the USB 1.1 controller.

⏮ **Disabled** USB 1.1 controller disabled

⏮ **Enabled** (DEFAULT) USB 1.1 controller enabled

⏮ **Onboard USB2.0 [Enabled]**

Use the **Onboard USB2.0** option to enable or disable the USB 2.0 controller.

⏮ **Disabled** USB 2.0 controller disabled

⏮ **Enabled** (DEFAULT) USB 2.0 controller enabled

⏮ **UART Port A [Disabled]**

Use the **UART Port A** option to select the I/O address and IRQ for the UART port A. The **UART Port A** options are:

- „ Disabled (Default)
- „ 3F8/IRQ4
- „ 2F8/IRQ3
- „ 3E8/IRQ4
- „ 2E8/IRQ3

5.4.1 Flat Panel Configuration

Use the **Flat Panel Configuration** menu (**BIOS Menu 6**) to set the configuration settings for the flat panel screen connected to the system.

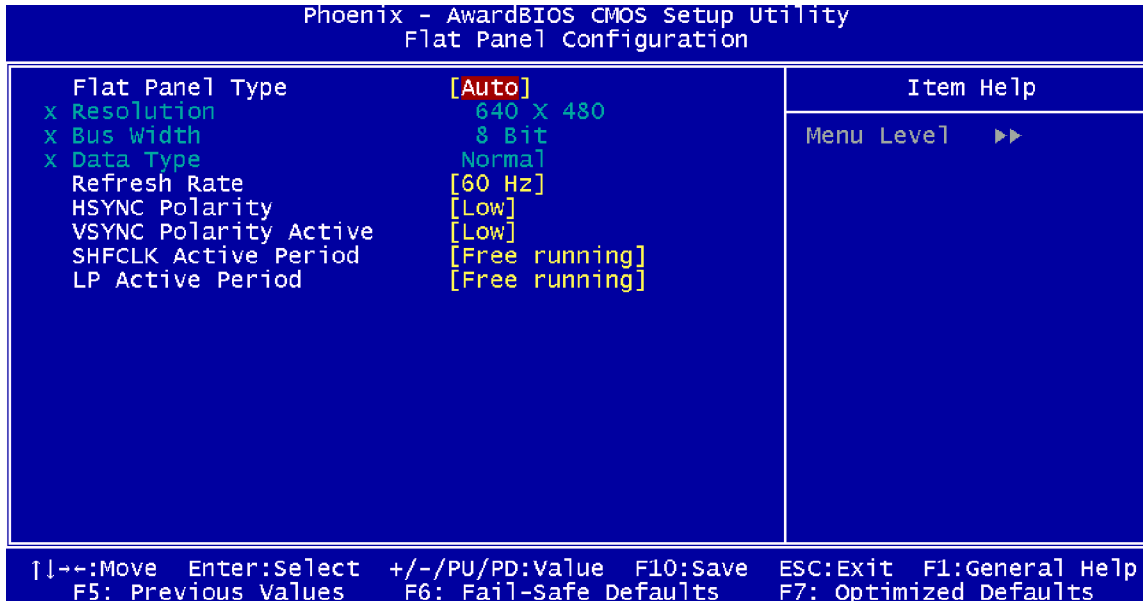

BIOS Menu 6: Flat Panel Configuration

Flat Panel Type [Auto]

Use the **Flat Panel Type** option to specify the type of flat panel screen connected to the system.

- ↑ **SSTN** Specifies the system is connected to a SSTN display.
- ↑ **DSTN** Specifies the system is connected to an DSTN display.
- ↑ **TFT** Specifies the system is connected to a TFT display.
- ↑ **LVDS** Specifies the system is connected to an LVDS display.
- ↑ **Auto** (Default) The system detects the display type and the display settings.

Resolution [640 x 480]

3302040

The **Resolution** option can only be configured if the **Flat Panel Type** option is not set to **Auto**. Use the **Resolution** option to set the resolution of the flat panel screen connected to the system. The **Resolution** options are:

- „ 640 x 480 (Default)
- „ 800 x 600
- „ 1024 x 768

↑ **Bus Width [8 Bit]**

The **Bus Width** option can only be configured if the **Flat Panel Type** option is not set to **Auto**. Use the **Data Bus Width** to specify the number of bits that can be transmitted to and from the selected display.

- „ 8 Bit
- „ 9 Bit
- „ 12 Bit
- „ 16 Bit
- „ 18 Bit
- „ 24 Bit

↑ **Data Type [Normal]**

The **Data Type** option can only be configured if the **Flat Panel Type** option is not set to **Auto**. Use the **Data Type** option to set the bus type used to transfer data between the system and the flat panel screen connected to the system. The **Data Type** options are:

- „ Normal (Default)
- „ 2 X

↑ **Refresh Rate [60Hz]**

The **Refresh Rate** option can only be configured if the **Flat Panel Type** option is not set to **Auto**. Use the **Refresh Rate** option to set the screen refresh rate required by the panel connected to the system. Check the documentation that came with the panel before setting this option. The **Refresh Rate** options are:

- „ 60Hz (Default)
- „ 65Hz
- „ 70Hz
- „ 72Hz
- „ 75Hz
- „ 85Hz

↑ **HSYNC Polarity [Low]**

The **HSYNC Polarity** option can only be configured if the **Flat Panel Type** option is not set to **Auto**. Use the **HSYNC Polarity** option to set the polarity of the HSYNC signal to the panel. The **HSYNC Polarity** options are:

- „ High
- „ Low (Default)

↑ **VSYNC Polarity Active [Low]**

The **VGSYNC Polarity Active** option can only be configured if the **Flat Panel Type** option is not set to **Auto**. Use the **VGSYNC Polarity Active** option to set the polarity of the VSYNC signal to the panel. The **VGSYNC Polarity Active** options are:

- „ High
- „ Low (Default)

↑ **SHFCLK Active Period [Free Running]**

Use the **SHFCLK Active Period** option to set the SHFCLK. The **SHFCLK Active Period** options are:

- „ Active Only
- „ Free running (Default)

↑ **LP Active Period [Free Running]**

Use the **LP Active Period** option to set the LDE/MOD signal to the panel. The **LP Active Period** options are:

- „ Active Only
- „ Free running (Default)

5.5 Integrated Peripherals

Use the **Integrated Peripherals** menu (**BIOS Menu 7**) to change the configuration options for the attached peripheral devices.

Phoenix - AwardBIOS CMOS Setup Utility
Integrated Peripherals

On-chip IDE Channel 1	[Enabled]	Item Help Menu Level ▶
Master Drive PIO Mode	[Auto]	
Slave Drive PIO Mode	[Auto]	
IDE Primary Master UDMA	[Auto]	
IDE Primary Slave UDMA	[Auto]	
IDE DMA transfer access	[Enabled]	
▶ IT8888 ISA Decode IO	[Press Enter]	
▶ IT8888 ISA Decode Memory	[Press Enter]	
IDE HDD Block Mode	[Enabled]	
Onboard FDC Controller	[Enabled]	
Onboard Serial Port 1	[3F8/IRQ4]	
Onboard Serial Port 2	[2F8/IRQ3]	
UART Mode Select	[Normal]	
RXD , TXD Active	[Hi,Lo]	
IR Transmission Delay	[Enabled]	
UR2 Duplex Mode	[Half]	
Use IR Pins	[IR-Rx2Tx2]	
Onboard Parallel Port	[378/IRQ7]	
Parallel Port Mode	[SPP]	

↑↓←→:Move Enter:Select +/-/PU/PD:Value F10:Save ESC:Exit F1:General Help
F5: Previous Values F6: Fail-Safe Defaults F7: Optimized Defaults

Phoenix - AwardBIOS CMOS Setup Utility
Integrated Peripherals

Slave Drive PIO Mode	[Auto]	Item Help Menu Level ▶
IDE Primary Master UDMA	[Auto]	
IDE Primary Slave UDMA	[Auto]	
IDE DMA transfer access	[Enabled]	
▶ IT8888 ISA Decode IO	[Press Enter]	
▶ IT8888 ISA Decode Memory	[Press Enter]	
IDE HDD Block Mode	[Enabled]	
Onboard FDC Controller	[Enabled]	
Onboard Serial Port 1	[3F8/IRQ4]	
Onboard Serial Port 2	[2F8/IRQ3]	
UART Mode Select	[Normal]	
RXD , TXD Active	[Hi,Lo]	
IR Transmission Delay	[Enabled]	
UR2 Duplex Mode	[Half]	
Use IR Pins	[IR-Rx2Tx2]	
Onboard Parallel Port	[378/IRQ7]	
Parallel Port Mode	[SPP]	
EPP Mode Select	[EPP1.7]	
ECP Mode Use DMA	[3]	

↑↓←→:Move Enter:Select +/-/PU/PD:Value F10:Save ESC:Exit F1:General Help
F5: Previous Values F6: Fail-Safe Defaults F7: Optimized Defaults

BIOS Menu 7: Integrated Peripherals

↑ On-Chip IDE Channel 0/1 [Enabled]

Use the **On-Chip IDE Channel 0/1** option to specify if the system uses the integrated primary IDE channel or not.

- ↑ **Disabled** The primary IDE channel is not used.
- ↑ **Enabled** (Default) The primary IDE channel is used.

↑ Drive PIO Mode [Auto]

Use the **Drive PIO Mode** options below to select the Programmed Input/Output (PIO) mode for the following HDDs:

- „ Master Drive PIO Mode
- „ Slave Drive PIO Mode

- ↑ **Auto** (Default) The computer selects the correct mode.
- ↑ **Mode 0** PIO mode 0 selected with a maximum transfer rate of 3.3MBps.
- ↑ **Mode 1** PIO mode 1 selected with a maximum transfer rate of 5.2MBps.
- ↑ **Mode 2** PIO mode 2 selected with a maximum transfer rate of 8.3MBps.
- ↑ **Mode 3** PIO mode 3 selected with a maximum transfer rate of 11.1MBps.
- ↑ **Mode 4** PIO mode 4 selected with a maximum transfer rate of 16.6MBps.
- ↑ **Mode 5** PIO mode 5 selected with a maximum transfer rate of 22.2MBps.

↑ IDE UDMA [Auto]

Use the **IDE UDMA** option below to select the Ultra DMA (UDMA) mode for the following HDDs:

- „ IDE Primary Master UDMA
- „ IDE Primary Slave UDMA

3302040

↑ **Auto** (Default) The computer selects the correct UDMA.

↑ **Disabled** The UDMA for the HDD device is disabled.

↑ **IDE DMA transfer access [Enabled]**

Use the **IDE DMA transfer access** option to enable or disable DMA support for IDE devices connected to the system.

↑ **Disabled** All IDE drive DMA transfers are disabled. The IDE drives use PIO mode transfers.

↑ **Enabled** (Default) All IDE drive DMA transfers are enabled.

↑ **IT8888 ISA Decode IO [Press Enter]**

Use the IDE ISA Decode IO option to open the IT8888 ISA Decode I/O menu. The IT8888 ISA Decode I/O options are shown in **Section 0**.

↑ **IT8888 ISA Decode Memory [Press Enter]**

Use the IDE ISA Decode Memory option to open the IT8888 ISA Decode Memory menu. The IT8888 ISA Decode Memory options are shown in **Section 5.5.2**.

↑ **IDE HDD Block Mode [Enabled]**

If the drive connected to the system supports block mode, use the **IDE HDD Block Mode** option to enable the system to detect the optimal number of block read/writes per sector the system IDE drive can support. Block mode is also called block transfer, multiple commands, or multiple sector read/write.

↑ **Disabled** Block mode is not supported.

↑ **Enabled** (Default) Block mode is supported.

↑ **Onboard FDC Controller [Enabled]**

Use the **Onboard FDC Controller** option to enable or disable the onboard floppy controller. If the system is not connected to a floppy disk or uses an adapter for the FDD, this option can be disabled.

- ↑ **Disabled** The FDD controller is disabled.
- ↑ **Enabled** (Default) The FDD controller is enabled.

↑ **Onboard Serial Port 1 [3F8/IRQ4]**

Use the **Onboard Serial Port 1** option to select the I/O address and IRQ for the onboard serial port 1. The serial port can be disabled or the I/O address and the IRQ can be automatically selected by the BIOS. The **Onboard Serial Port 1** options are:

- „ Disabled
- „ 3F8/IRQ4 (Default)
- „ 2F8/IRQ3
- „ 3E8/IRQ4
- „ 2E8/IRQ3
- „ Auto

↑ **Onboard Serial Port 2 [2F8/IRQ3]**

Use the **Onboard Serial Port 2** option to select the I/O address and IRQ for the onboard serial port 2. The serial port can be disabled or the I/O address and the IRQ can be automatically selected by the BIOS. The **Onboard Serial Port 2** options are:

- „ Disabled
- „ 3F8/IRQ4
- „ 2F8/IRQ3 (Default)
- „ 3E8/IRQ4
- „ 2E8/IRQ3
- „ Auto

↑ **UART Mode Select [Normal]**

Use the **UART Mode Select** to select the UART mode for the system.

Normal	(Default) RS-232C serial port
IrDA	Infrared port compliant with IrDA specification
ASK IR	Amplitude shift keyed infrared port

↑ x RxD, TxD Active [Hi,Lo]

The **RxD, TxD Active** option can only be selected if the **UART Mode Select** option is set to IrDA mode or ASKIR mode. Use the **RxD, TxD Active** option to set the infrared reception (RxD) and transmission (TxD) polarity. The **RxD, TxD Active** options are:

- „ Hi, Hi
- „ Hi, Lo (Default)
- „ Lo, Hi
- „ Lo, Lo

↑ x IR Transmission Delay [Enabled]

Use the **IR Transmission Delay** option to enable or disable IR transmission delays.

- ↑ **Disabled** IR transmission are not delayed.
- ↑ **Enabled** (Default) IR transmission are delayed.

↑ x UR2 Duplex Mode [Half]

Use the **UR2 Duplex Mode** option to specify the transmission mode for the IR port device.

- ↑ **Full** Simultaneous bi-directional transmission occurs.
- ↑ **Half** (Default) Transmission only occurs in one direction at a time.

↑ x Use IR Pins [IR-Rx2Tx2]

Use the **Use IR Pins** options to specify how the IR pins respond. The **Use IR Pins** options are:

- „ RxD2,TxD2
- „ IR-Rx2Tx2 (Default)

Onboard Parallel Port [378/IRQ7]

Use the **Onboard Parallel Port** option to specify a logical LPT port address and corresponding interrupt for the physical parallel port. The **Onboard Parallel Port** options are:

- „ Disabled
- „ 378/IRQ7 (Default)
- „ 3BC/IRQ7

Parallel Port Mode [SPP]

Use the **Parallel Port Mode** option to select parallel port operation mode.

 **SPP** (Default) The parallel port operates in the standard parallel port (SPP) mode. This parallel port mode works with most parallel port devices but is slow.

 **EPP** The parallel port operates in the enhanced parallel port mode (EPP). The EPP mode supports bi-directional communication between the system and the parallel port device and the transmission rates between the two are much faster than the SPP mode.

 **ECP** The parallel port operates in the extended capabilities port (ECP) mode. The ECP mode supports bi-directional communication between the system and the parallel port device and the transmission rates between the two are much faster than the SPP mode.

3302040

 **ECP+EPP** The parallel port is compatible with both ECP and EPP devices.

 **Normal**

x EPP Mode Select [EPP1.7]

The **EPP Mode Select** option is only available if the **Parallel Port Mode** option is set to EPP mode. Use the **EPP Mode Select** option to select the parallel port mode standard for the parallel port.

 **EPP1.9** EPP 1.9 is selected as the EPP standard.

 **EPP1.7** (Default) EPP 1.7 is selected as the EPP standard.

x ECP Mode Use DMA [3]

The **ECP Mode Use DMA** option is only available if the **Parallel Port Mode** option is set to ECP mode. Use the **ECP Mode Use DMA** option to specify the DMA channel the parallel port must use in the ECP mode.

 **1** The parallel port uses DMA Channel 1 in ECP mode.

 **3** (Default) The parallel port uses DMA Channel 3 in ECP mode.

5.5.1 IT8888 ISA Decode IO

**NOTE:**

Five PCI-104 devices can be stacked onto the 3302040 motherboard. If these devices are stacked onto the board, the ISA bus space should be enabled. If no PCI-104 devices are being used, disable all the buses. Disabling these buses frees up system resources that can be allocated to other system applications.

Use the **IT8888 ISA Decode IO** menu (**BIOS Menu 8**) to set the IO memory range for the onboard ISA.

```

Phoenix - AwardBIOS CMOS Setup Utility
IT8888 ISA Decode IO

Decode I/O Space 0      [Enabled]
Decode I/O Speed 0     [Slow Speed]
Decode I/O Addr. 0 [15:0] [0100]
Decode I/O Size 0      [ 64 Bytes]
Decode I/O Space 1     [Enabled]
Decode I/O Speed 1     [Slow Speed]
Decode I/O Addr. 1 [15:0] [0200]
Decode I/O Size 1      [128 Bytes]
Decode I/O Space 2     [Enabled]
Decode I/O Speed 2     [Slow Speed]
Decode I/O Addr. 2 [15:0] [0280]
Decode I/O Size 2      [ 16 Bytes]
Decode I/O Space 3     [Enabled]
Decode I/O Speed 3     [Slow Speed]
Decode I/O Addr. 3 [15:0] [0300]
Decode I/O Size 3      [ 64 Bytes]
Decode I/O Space 4     [Enabled]
Decode I/O Speed 4     [Slow Speed]
Decode I/O Addr. 4 [15:0] [0380]

Item Help
Menu Level  >>

↑↓←→:Move Enter:Select +/-/PU/PD:Value F10:Save ESC:Exit F1:General Help
F5: Previous Values F6: Fail-Safe Defaults F7: Optimized Defaults

```

```

Phoenix - AwardBIOS CMOS Setup Utility
IT8888 ISA Decode IO

Decode I/O Speed 1     [Slow Speed]
Decode I/O Addr. 1 [15:0] [0200]
Decode I/O Size 1      [128 Bytes]
Decode I/O Space 2     [Enabled]
Decode I/O Speed 2     [Slow Speed]
Decode I/O Addr. 2 [15:0] [0280]
Decode I/O Size 2      [ 16 Bytes]
Decode I/O Space 3     [Enabled]
Decode I/O Speed 3     [Slow Speed]
Decode I/O Addr. 3 [15:0] [0300]
Decode I/O Size 3      [ 64 Bytes]
Decode I/O Space 4     [Enabled]
Decode I/O Speed 4     [Slow Speed]
Decode I/O Addr. 4 [15:0] [0380]
Decode I/O Size 4      [ 16 Bytes]
Decode I/O Space 5     [Enabled]
Decode I/O Speed 5     [Slow Speed]
Decode I/O Addr. 5 [15:0] [0A78]
Decode I/O Size 5     [ 4 Bytes]

Item Help
Menu Level  >>

↑↓←→:Move Enter:Select +/-/PU/PD:Value F10:Save ESC:Exit F1:General Help
F5: Previous Values F6: Fail-Safe Defaults F7: Optimized Defaults

```

BIOS Menu 8: IT8888 ISA Decode IO

The **IT8888 ISA Decode IO** menu has the following common options:

- „ Decode I/O Space N
- „ Decode I/O Speed N
- „ Decode I/O Addr. N [15:0]
- „ Decode I/O Size N

Where N is an integer in the set [1, 2, 3, 4, 5] and represents a set for the PCI-104 devices that are attached to the system.

Decode IO Space N [Enabled]

Use the **Decode IO Space N** option to allocate system resources to the ISA bridge and to enable the Nth PCI-104 to function correctly.

 **Disabled** The Nth IO set is disabled and the system resources are reallocated to other applications.

 **Enabled** (Default) The Nth IO set is enabled and dedicated system resources are allocated to the Nth ISA bus.

Decode IO Speed N [Fast Speed]

Use the **Decode IO Speed N** option to specify the speed of the Nth ISA bus. The following options are available:

- „ Fast Speed
- „ Middle Speed
- „ Slow Speed
- „ Subtractive Speed

Decode IO Address N 0:15 [xx]

Use the **Decode IO Address N 0:15** option to allocate an address to the ISA bus. The address may range from **0001** to **FFFF**.

Decode IO Size N [Fast Speed]

Use the **Decode IO Size N** option to specify the size of the ISA bus. The following options are available:

- „ 1 Byte
- „ 2 Bytes
- „ 4 Bytes

3302040

- ” 8 Bytes
- ” 16 Bytes
- ” 32 Bytes
- ” 64 Bytes
- ” 128 Bytes

5.5.2 IT8888 ISA Decode Memory



NOTE:

Five PCI-104 devices can be stacked onto the 3302040 motherboard. If these devices are stacked onto the board, the ISA memory should be enabled. If no PCI-104 devices are being used, disable all the memory allocations for these buses. Disabling the memory allocations frees up system resources that can be allocated to other system applications.

Use the **IT8888 ISA Decode Memory (BIOS Menu 9)** to set the resources for the onboard ISA bus.

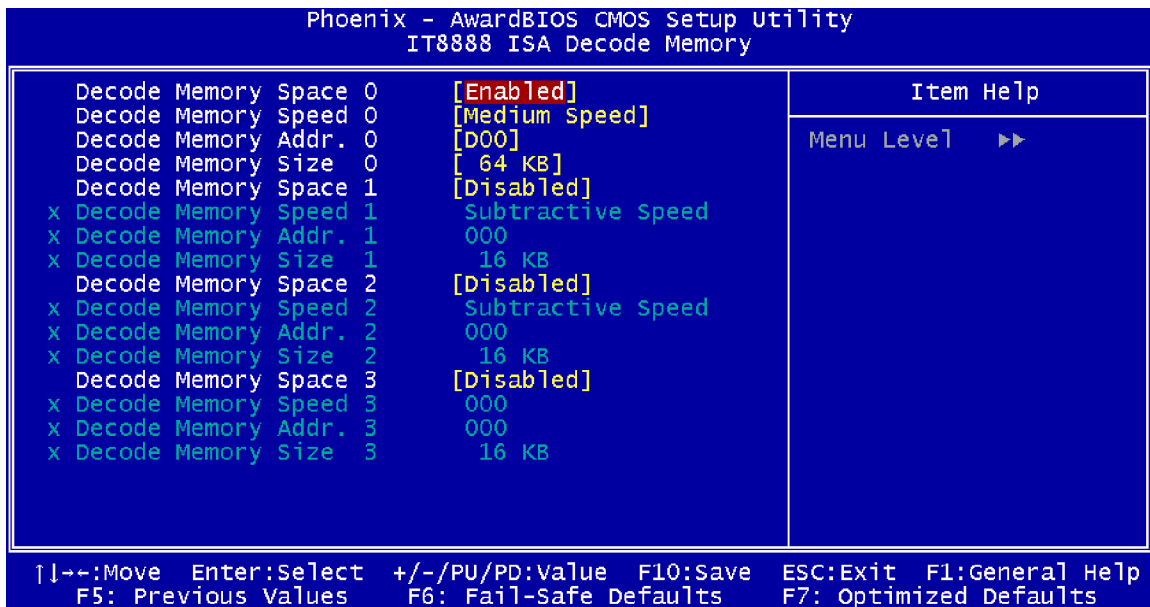

BIOS Menu 9: IT8888 ISA Decode Memory

The **IT8888 ISA Decode IO Memory** menu has the following common options:

- „ Decode Memory Space N
- „ Decode Memory Speed N
- „ Decode Memory Addr. N [15:0]
- „ Decode Memory Size N

Where N is an integer in the set [1, 2, 3, 4, 5] and represents a memory set for the PCI-104 devices that are attached to the system.

↑ Decode Memory Space N [Enabled]

Use the **Decode IO Memory N** option to allocate memory resources to the ISA bridge and to enable the PCI-104 to function correctly.

↑ **Disabled** The Nth memory set is disabled and the system memory resources are reallocated to other applications.

↑ **Enabled** (Default) The Nth memory set is enabled and dedicated system memory resources are allocated to the ISA bus.

↑ **Decode Memory Speed N [Fast Speed]**

Use the **Decode Memory Speed N** option to specify the memory speed of the ISA bus.

The following options are available:

- „ Fast Speed
- „ Middle Speed
- „ Slow Speed
- „ Subtractive Speed

↑ **Decode Memory Address N [xx]**

Use the **Decode Memory Address N** option to allocate an address to the memory of the ISA bus. The address may range from **0001** to **FFFF**.

↑ **Decode Memory Size N [xx]**

Use the Decode Memory **Size N** option to specify the memory size of the ISA bus. The following options are available:

- „ 16 KB
- „ 32 KB
- „ 64 KB
- „ 128 KB
- „ 256 KB
- „ 512 KB
- „ 1 MB
- „ 2 MB

5.6 Power Management Setup

Use the **Power Management Setup** menu (**BIOS Menu 10**) to set the BIOS power management and saving features.

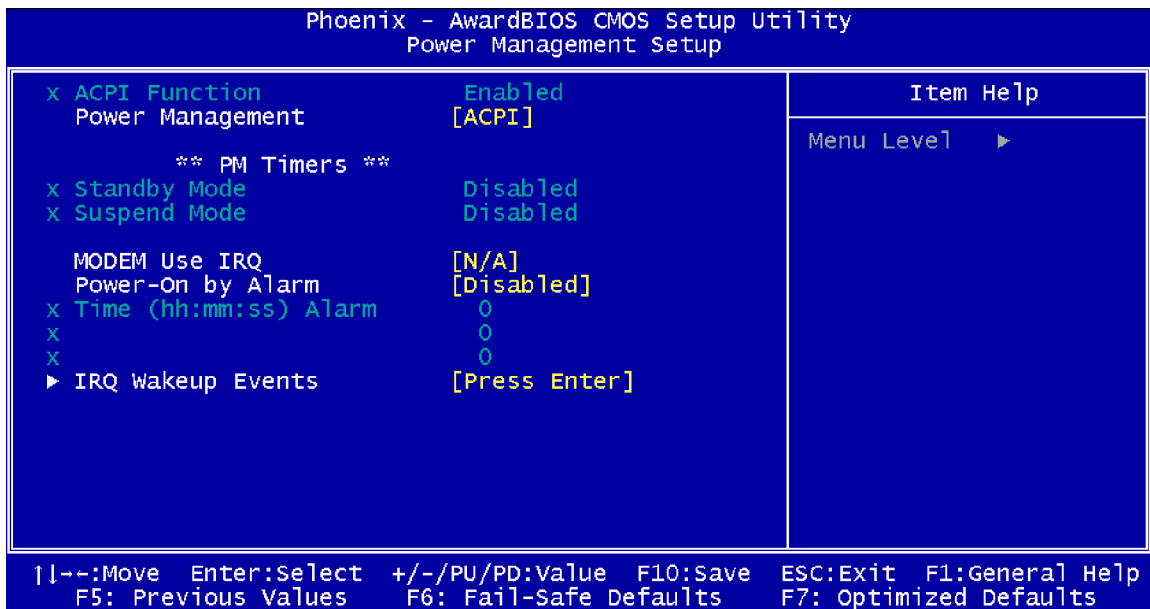

BIOS Menu 10: Power Management Setup

⏪ ACPI Function [Disabled]

The **ACPI Function** option is not user configurable.

⏪ Power Management [ACPI]

Use the **Power Management** option to set the power management type used by the system.

⏪ Disabled

All power management options are turned off. The only user configurable options are the power button and alarm settings.

⏪ Legacy

Standby and suspend modes can be set.

⏪ APM

Advanced power management (APM) is activated

ACPI (Default) Advanced Configuration and Power Interface (ACPI) is activated.

↑ x Standby Mode [Disabled]

The **Standby Mode** option can only be selected if the **Power Management** option is set to Legacy. The **Standby Mode** specifies the amount of time the system can be inactive before the system enters standby mode. The **Standby Mode** options are:

- „ Disabled (Default)
- „ 1 Sec
- „ 5 Sec
- „ 10 Sec
- „ 15 Sec
- „ 30 Sec
- „ 45 Sec
- „ 1 Min
- „ 5 Min
- „ 10 Min
- „ 15 Min
- „ 30 Min
- „ 45 Min
- „ 60 Min
- „ 90 Min
- „ 120 Min

↑ x Suspend Mode [Disabled]

The **Suspend Mode** option can only be selected if the **Power Management** option is set to Legacy. The **Suspend Mode** specifies the amount of time the system can be inactive before the system enters suspend mode. The **Suspend Mode** options are:

- „ Disabled (Default)
- „ 1 Sec
- „ 5 Sec
- „ 10 Sec
- „ 15 Sec
- „ 30 Sec
- „ 45 Sec

- ” 1 Min
- ” 5 Min
- ” 10 Min
- ” 15 Min
- ” 30 Min
- ” 45 Min
- ” 60 Min
- ” 90 Min
- ” 120 Min

Modem Use of IRQ [N/A]



Use the **Modem Use of IRQ** to select the IRQ address for the system modem. The following IRQ addresses are available.

- ” N/A (Default)
- ” 3
- ” 4
- ” 5
- ” 7
- ” 9
- ” 10
- ” 11

5.6.1 Power Management

Power-On by Alarm [Disabled]

Use the **Power-On by Alarm** option to specify when the computer is roused from a suspended state.

-  **Disabled** (Default) The real time clock (RTC) cannot generate a wake event
-  **Enabled** If selected, the following appears with values that can be selected:

↑ RTC Alarm Date (Days)

↑ System Time

After setting the alarm, the computer will turn itself on from a suspend state when the alarm goes off.

↑ IRQ Wakeup Events [Press Enter]

To view the **IRQ Wakeup Events** options press **ENTER**.

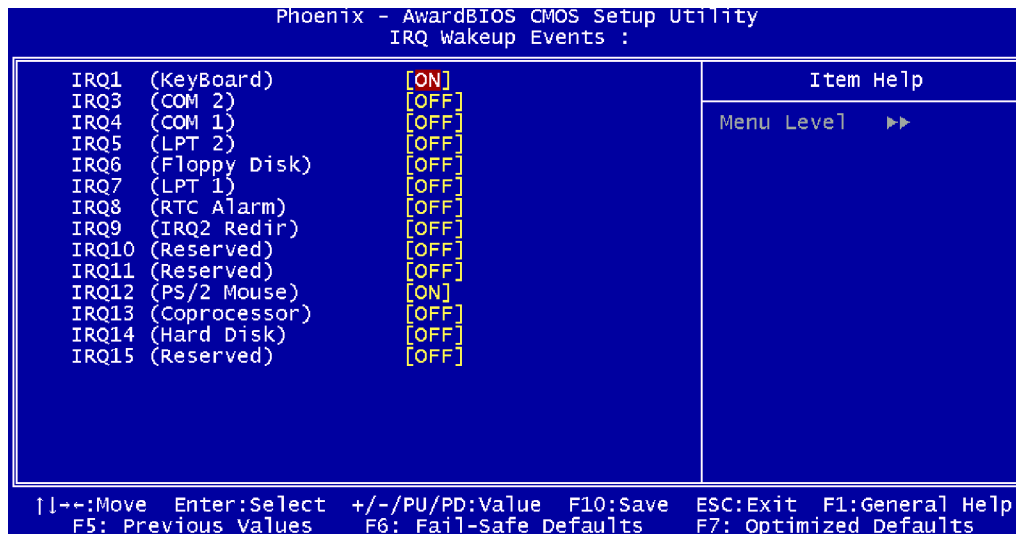

BIOS Menu 11: IRQ Wakeup Events

If the Primary INTR was selected as ON, the IRQs can be monitored and used to generate wake events. The following IRQs are monitored:

„	IRQ1	(Keyboard)	ON
„	IRQ3	(COM 2)	OFF
„	IRQ4	(COM 1)	OFF
„	IRQ5	(LPT 2)	OFF
„	IRQ6	(Floppy Disk)	OFF
„	IRQ7	(LPT)	OFF
„	IRQ8	(RTC Alarm)	OFF

„	IRQ9	(IRQ2 Redir)	OFF
„	IRQ10	(Reserved)	OFF
„	IRQ11	(Reserved)	OFF
„	IRQ12	(PS/2 Mouse)	ON
„	IRQ13	(Coprocessor)	OFF
„	IRQ14	(Hard Disk)	OFF
„	IRQ15	(Reserved)	OFF

5.7 PnP/PCI Configurations

Use the **PnP/PCI Configurations** menu (**BIOS Menu 12**) to set the plug and play, and PCI options.

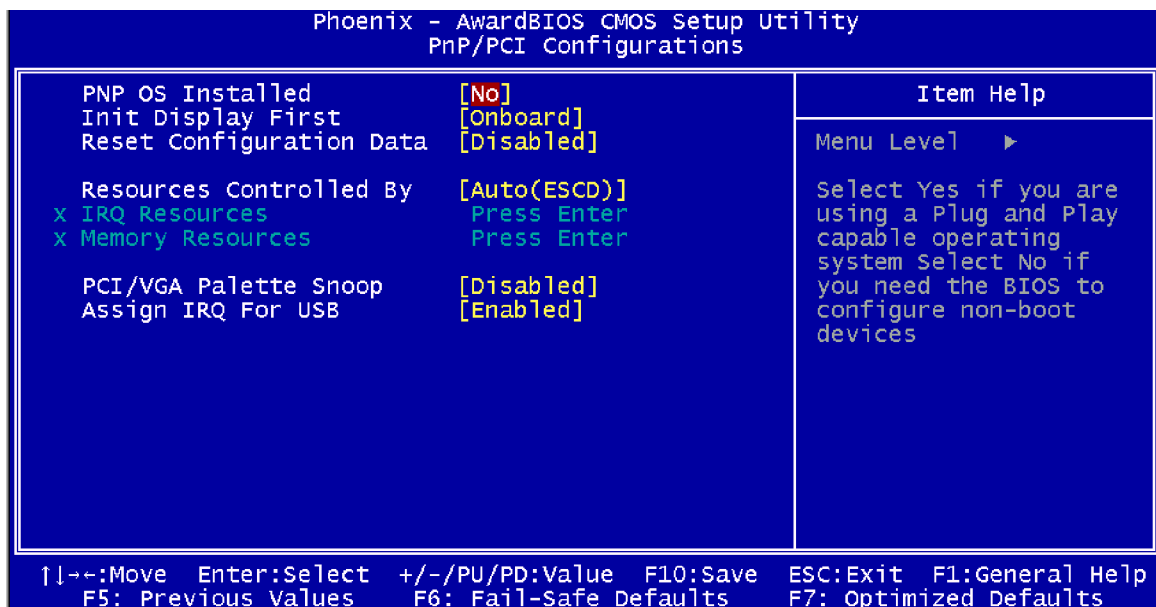

BIOS Menu 12: PnP/PCI Configurations

⌄ PNP OS Installed [No]

The **PNP OS Installed** option determines whether the Plug and Play devices connected to the system are configured by the operating system or the BIOS.

- ⌄ **No** (Default) If the operating system does not meet the Plug and Play specifications, BIOS configures all the devices in the system.

3302040



Yes

Set this option if the system is running Plug and Play aware operating systems. The operating system changes the interrupt, I/O, and DMA settings.



Init. Display First [Onboard]

Use the **Init. Display First** option to select the graphics controller the system uses as a primary boot device. The options are:

- „ PCI Slot
- „ Onboard (Default)



Reset Configuration Data [Disabled]

Use the **Reset Configuration Data** option to reset the Extended System Configuration Data (ESCD) when exiting setup if booting problems occur after a new add-on is installed.



Disabled

(Default)

ESCD will not be reconfigured



Enabled

ESCD will be reconfigured after you exit setup



Resources Controlled By [Auto (ESCD)]

Use the **Resources Controlled By** option to either manually configure all the boot and plug and play devices, or allow BIOS to configure these devices automatically. If BIOS is allowed to configure the devices automatically IRQs, DMA and memory base address fields cannot be set manually.



Auto(ESCD)

(Default)

BIOS automatically configures plug and play devices as well as boot devices.



Manual

Manually configure the plug and play devices and any other boot devices.



x IRQ Resources [Press Enter]

The **IRQ Resources** option (**BIOS Menu 13**) can only be selected if the **Resources Controlled By** option is set to **Manual**.

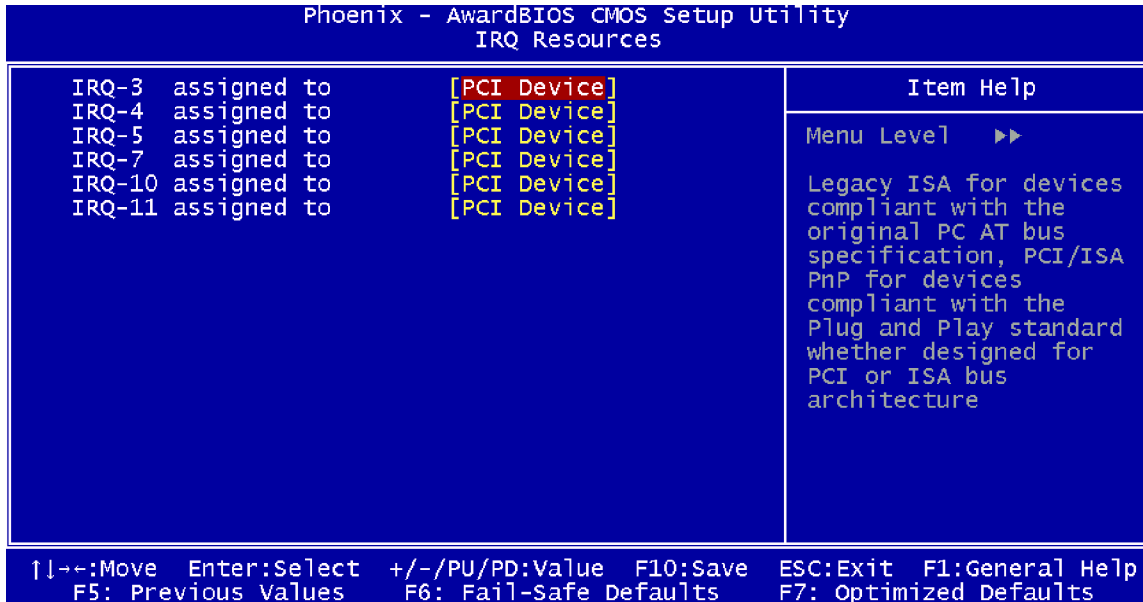

BIOS Menu 13: IRQ Resources

The **IRQ Resources** menu has the following options:

- „ IRQ-3 assigned to
- „ IRQ-4 assigned to
- „ IRQ-5 assigned to
- „ IRQ-7 assigned to
- „ IRQ-10 assigned to
- „ IRQ-11 assigned to

The above options all have the following default options.



PCI Device (Default)

The IRQ is assigned to legacy ISA for devices compliant with the original PC AT bus specification, PCI/ISA PNP for devices compliant with the Plug and Play standard whether designed for PCI or ISA bus architecture.

3302040



Reserved

The IRQ is reserved by BIOS.



x Memory Resources [Press Enter]

The **Memory Resources** menu (**BIOS Menu 14**) can only be accessed if the **Resources Controlled By** option is set to **Manual**. Use **Memory Resources** to select a base address and the length for the memory area used by a peripheral that requires high memory.

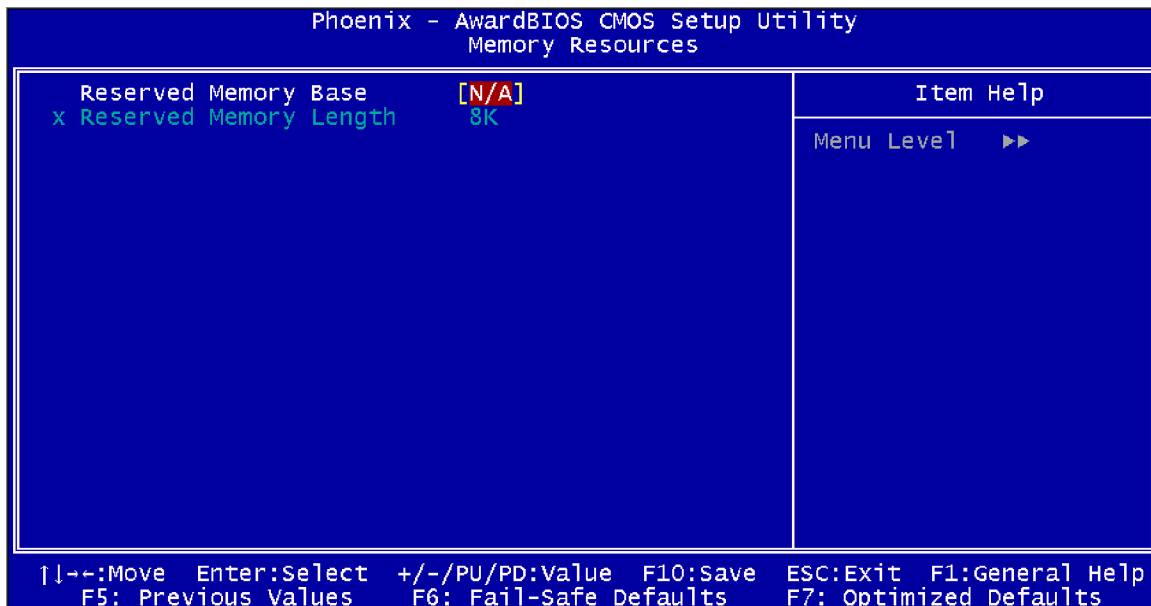

BIOS Menu 14: Memory Resources

The menu has two configurable options:

- „ Reserved Memory Base
- „ Reserved Memory Length



Reserved Memory Base [N/A]

The **Reserved Memory Base** option specifies the base address for the peripheral device.

The **Reserved Memory Base** options are:

- „ N/A (Default)
- „ C800
- „ CC00

- „ D000
- „ D400
- „ D800
- „ DC00



x Reserved Memory Length [8K]

The **Reserved Memory Length** option can only be accessed if the **Reserved Memory Base** option is not set to **N/A**. The **Reserved Memory Length** specifies the amount of memory reserved for the peripheral device. The **Reserved Memory Length** options:

- „ 8K (Default)
- „ 16K
- „ 32K
- „ 64K

PCI/VGA Palette Snoop [Disabled]

Use the **PCI/VGA Palette Snoop** option enables the system to determine whether or not some special VGA cards, high-end hardware MPEG decoders and other similar devices are allowed to look at the VGA palette on the video card so these devices can determine what colors are in use. This option is needed *very rarely* and should be left "Disabled" unless a video device specifically requires the setting to be enabled upon installation.

- | | | |
|---|---------------------------|--|
|  | Disabled (Default) | Does not allow the graphics devices to examine the VGA palette on the graphics card. |
|  | Enabled | Allows the graphics devices to examine the VGA palette on the graphics card. |

Assign IRQ for USB [Enabled]

Use the **Assign IRQ for USB** option to enable the system to allocate an interrupt address to the system USB display.

- | | | |
|---|-----------------|-------------------------------|
|  | Disabled | No IRQ is assigned to the USB |
|---|-----------------|-------------------------------|

3302040

 **Enabled** (Default) An IRQ is assigned to the USB

5.8 PC Health Status

The **PC Health Status** menu (**BIOS Menu 15**) has no user configurable options, but shows system operating parameters that are essential to the stable operation of the system.

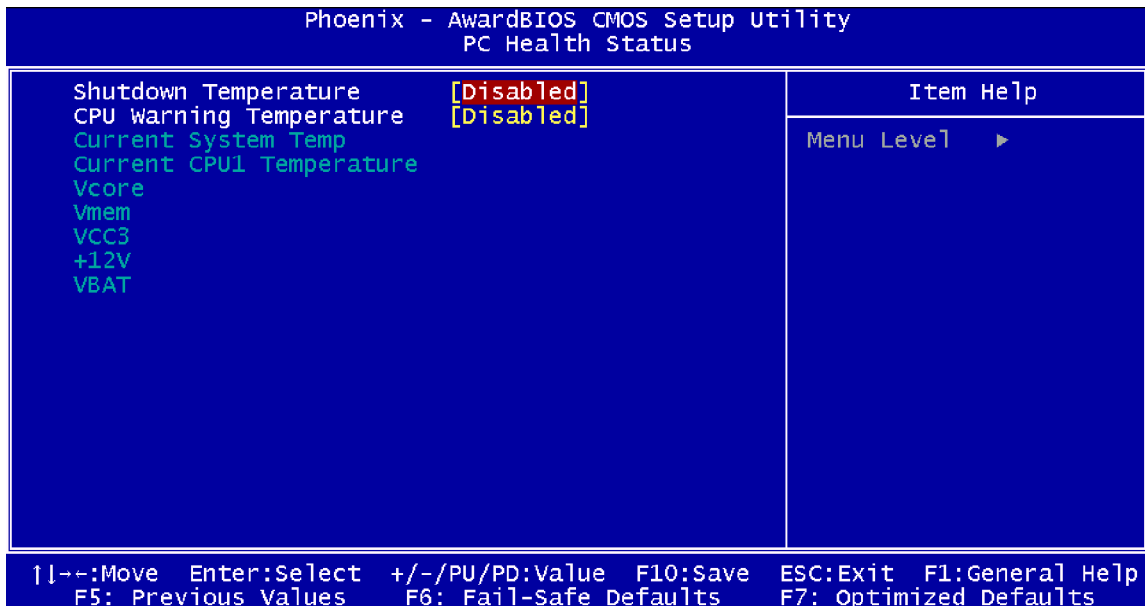

BIOS Menu 15: PC Health Status

The following system parameters are monitored by the **PC Health Status** menu.

Shutdown Temperature [Disabled]

Use the **Shutdown Temperature** option to specify at what CPU temperature should the system shut down to protect the system from overheating. The following configuration options are available:

- .. 60°C/140°F
- .. 65°C/149°F
- .. 70°C/158°F
- .. Disabled (Default)

↑ CPU Warning Temperature [Disabled]

Use the **CPU Warning Temperature** option to specify at what CPU temperature should the system issue a warning. The following configuration options are available:

- „ Disabled (Default)
- „ 50°C/122°F
- „ 53°C/127°F
- „ 56°C/133°F
- „ 60°C/140°F
- „ 63°C/145°F
- „ 66°C/151°F
- „ 70°C/158°F

↑ System Temperature

The following temperatures are monitored:

- „ System Temperature
- „ Current CPU Temperature

↑ Voltages

The following voltages are monitored:

- „ Vcore
- „ Vmem
- „ VCC3
- „ +12 V
- „ VBAT

Chapter

6

Software Drivers

6.1 Available Software Drivers



NOTE:

The content of the CD may vary throughout the life cycle of the product and is subject to change without prior notice. You may visit the Global American, Inc website or contact technical support for the latest updates.

There are five software drivers for the 3302040 motherboard installed in the subsystem:

- „ VGA Driver
- „ Audio Driver
- „ LAN Driver
- „ SATA/RAID Driver
- „ ISA Driver

All five drivers can be found on the CD that came with the CPU card. To install the drivers please follow the instructions in the sections below.

Insert the CD into the system that contains the 3302040 CPU card.



NOTE:

If your system does not run the "autorun" program when the CD is inserted, click the **Start** button, select **Run**, then type **X:\autorun.exe** (replace **X** with the actual drive letter for your CD-ROM) to access the Global American, Inc **Driver CD** main menu.

Step 5: From the AMD LX/GX Driver CD main menu (**Figure 6-1**), click **3302040**.

3302040

Step 6: A window appears listing the drivers available for installation.

Step 7: Select any item from the list to view more information on the driver installation, or select Manual to navigate to the 3302040 user manual.

The following sections fully describe the driver installation procedures for the 3302040 CPU card.

6.2 VGA Driver

To install the VGA driver please follow the steps below.

Step 1: Open **Windows Control Panel** (**Figure 6-3**).

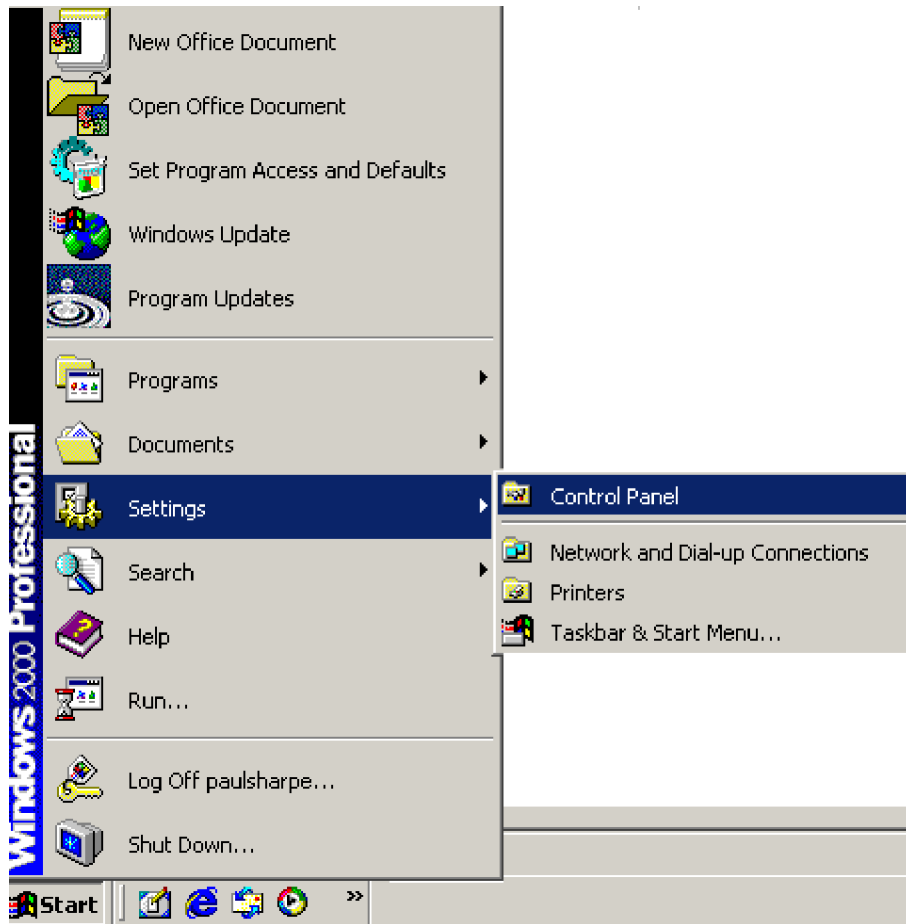

Figure 6-3: Access Windows Control Panel

Step 2: Double click the **System** icon (Figure 6-4).

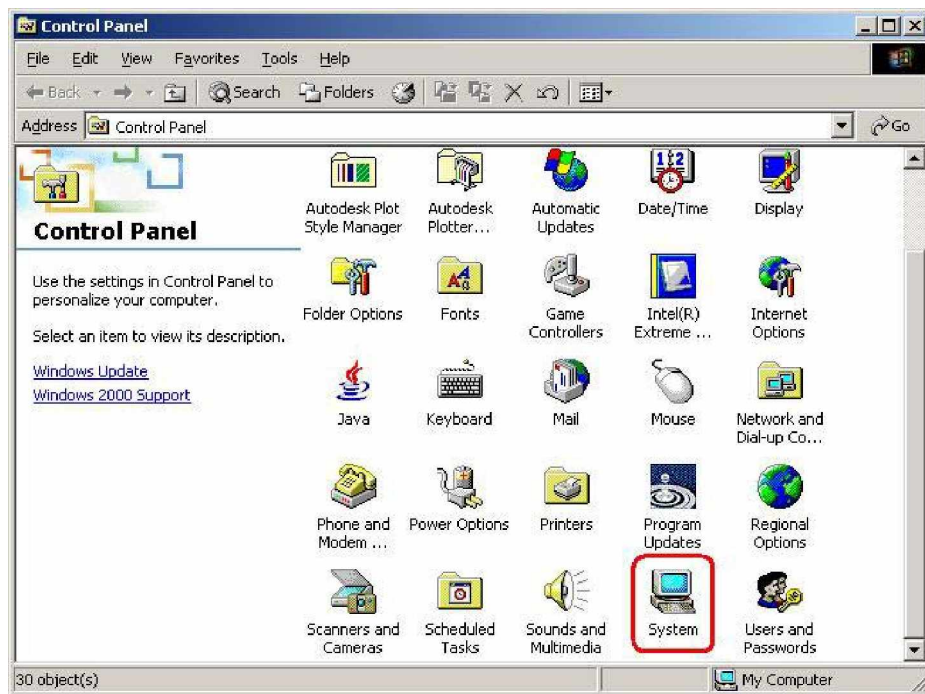

Figure 6-4: Double Click the System Icon

Step 3: Double click the **Device Manager** tab (Figure 6-5).

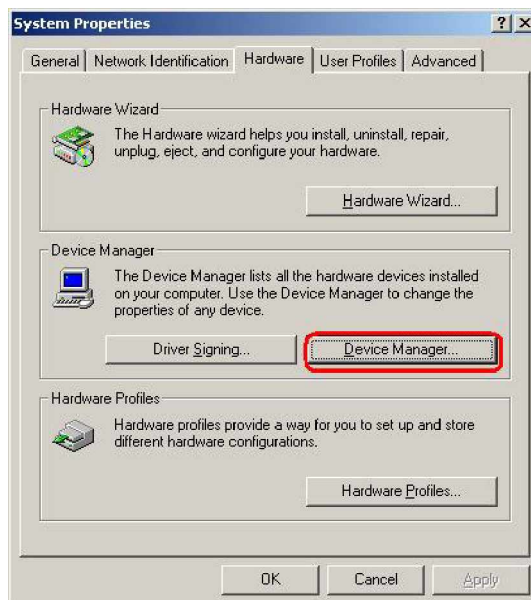

Figure 6-5: Double Click the Device Manager Tab

Step 4: A list of system hardware devices appears (Figure 6-6).

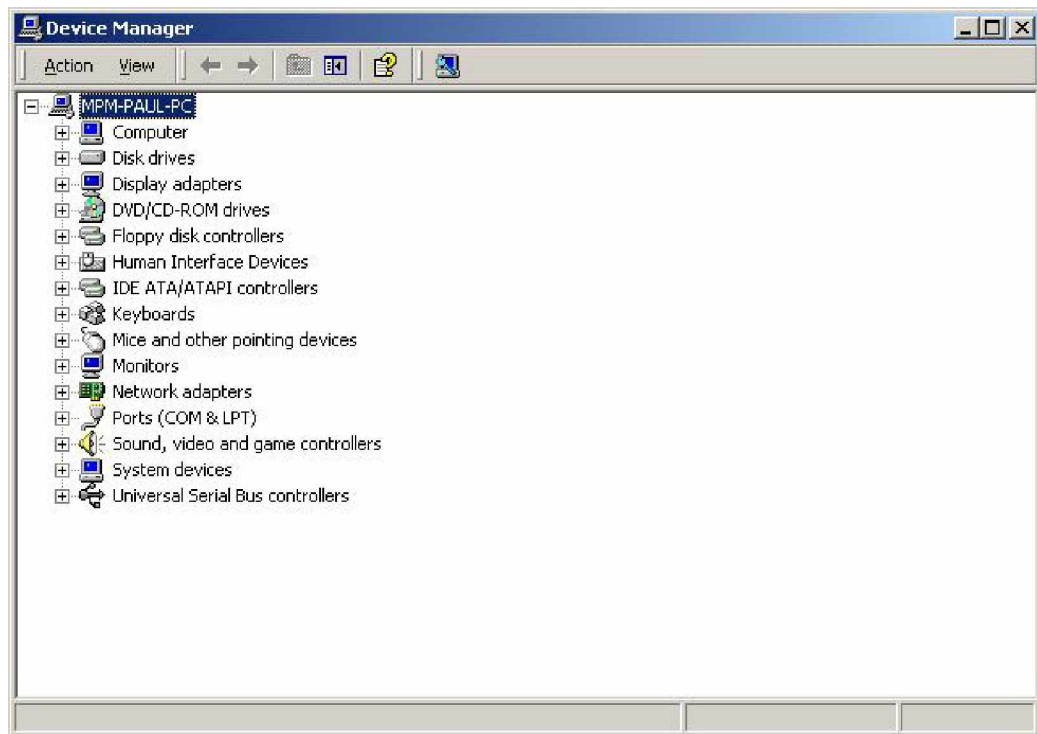

Figure 6-6: Device Manager List

Step 5: Expand the **Display Adapters** category (**Figure 6-7**). Right click the adapter and select **Properties**.



NOTE:

If the **Display Adapters** category is not available, navigate to **X:\VGALX800\XP\VGA 2.01.05** (where **X:** is the system CD drive) and read the **ReleaseNotes.txt** file for further information on installing the VGA driver.

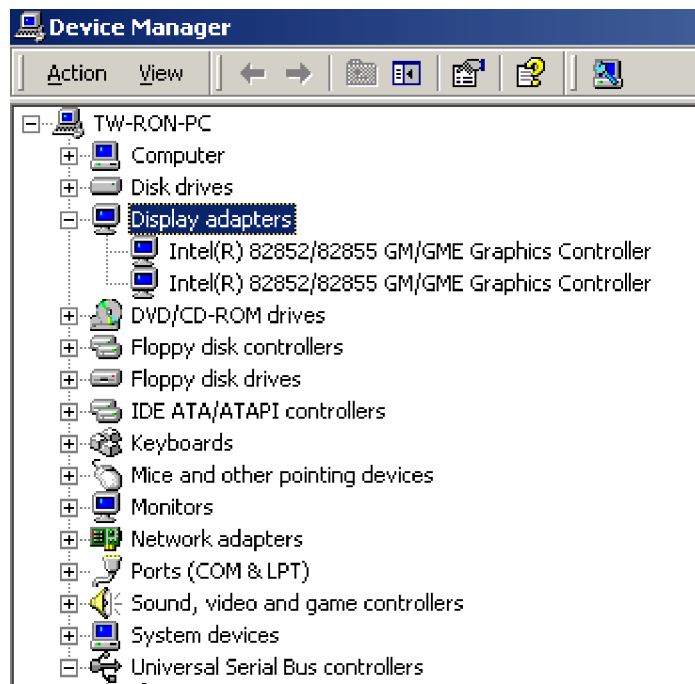

Figure 6-7: Expand the Display Adapters Category

Step 6: From the **Driver** tab of the **Properties** window, click **Update Driver** (Figure 6-8) or, click **Reinstall Driver** if **Update Driver** is not seen.

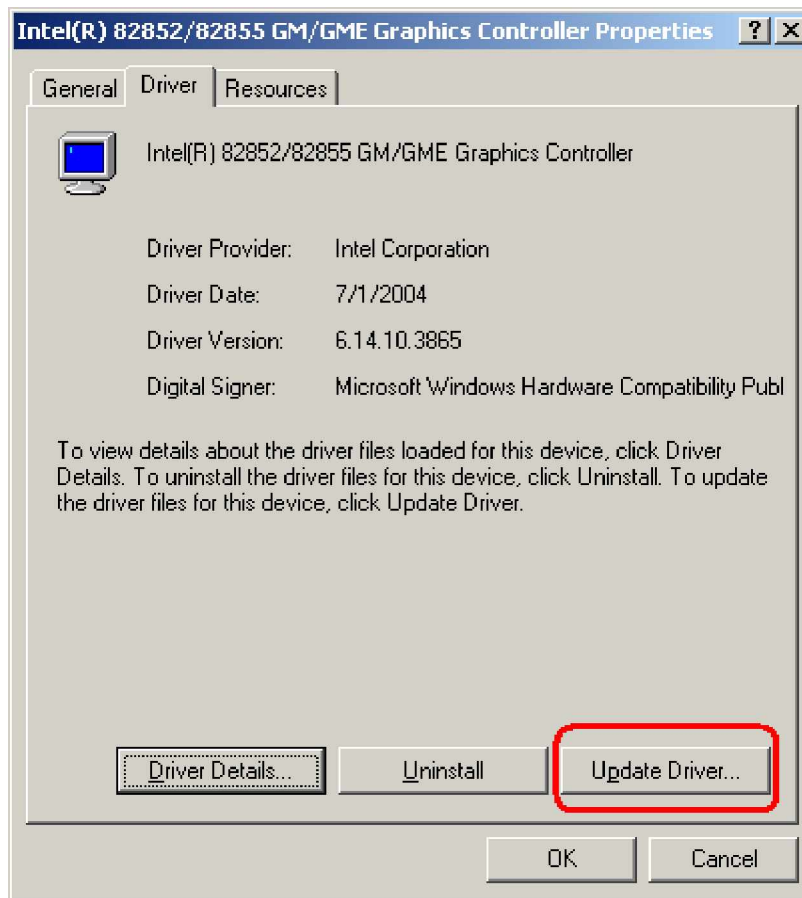

Figure 6-8: Update Driver

Step 7: The **Upgrade Device Driver Wizard** appears (**Figure 6-9**). Click **NEXT** to continue.



Figure 6-9: Upgrade Device Driver Wizard

Step 8: The **Install Hardware Device Driver** screen appears (**Figure 6-10**). Select the **Search for a suitable driver for my device** radio button and click **NEXT** to continue.



Figure 6-10: Search for Suitable Driver

- Step 9:** Select **Specify a Location** in the **Locate Driver Files** window (**Figure 6-11**).
- Click **NEXT** to continue.



Figure 6-11: Locate Driver Files

Step 10: Click **Browse** and navigate to the `X:\AMD\DX800\XP\VGA 2.01.05` directory, where “X:” is the system CD drive (**Figure 6-12**).



Figure 6-12: Location Browsing Window

Step 11: Click **OK** to continue.

Step 12: A driver files location menu window appears. Click NEXT to continue. The driver is installed.

6.3 Audio Driver Installation

To install the audio driver please follow the steps below.

Step 1: Open **Windows Control Panel (Figure 6-13)**.

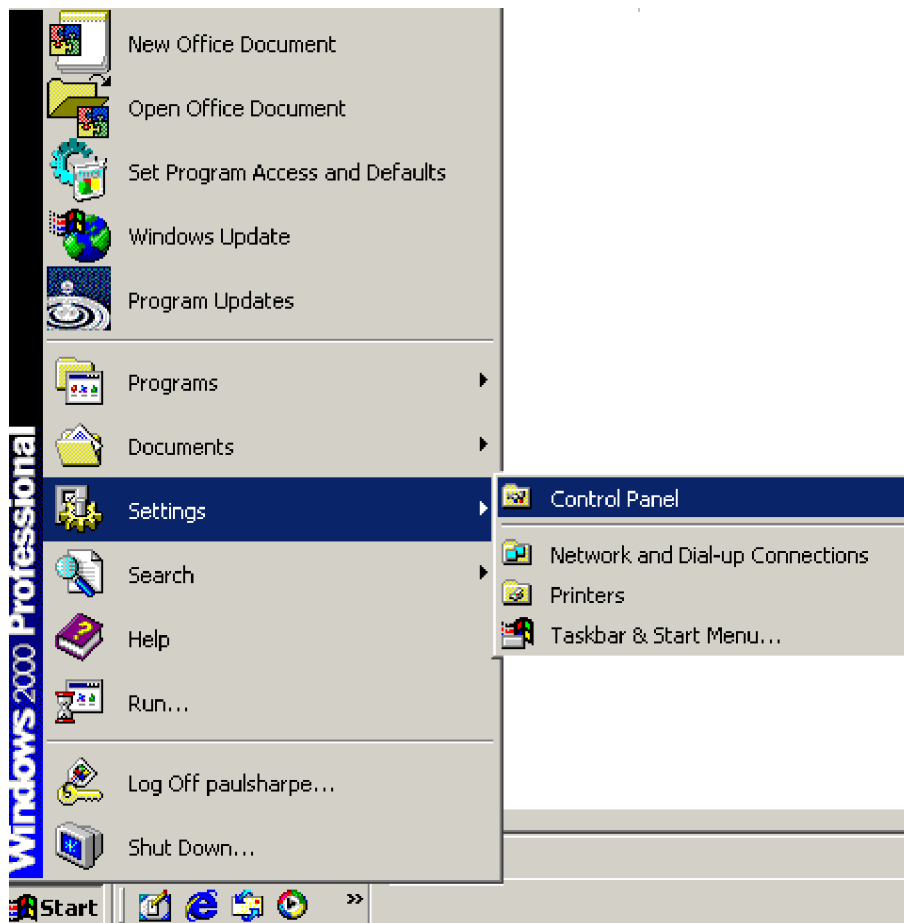

Figure 6-13: Access Windows Control Panel

Step 2: Double click the **System** icon (Figure 6-14).

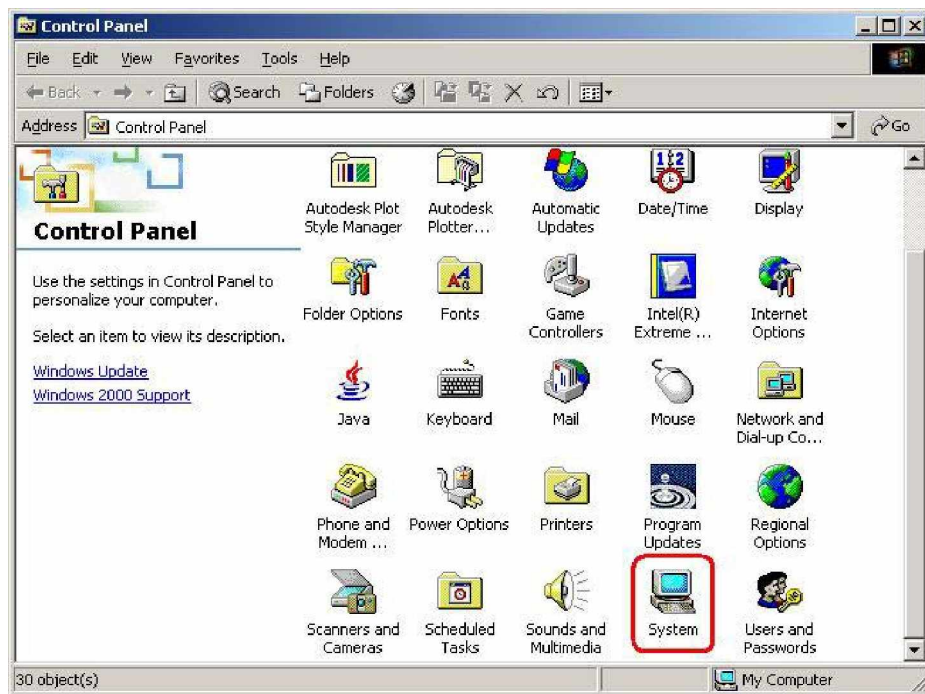

Figure 6-14: Double Click the System Icon

Step 3: Double click the **Device Manager** tab (Figure 6-15).

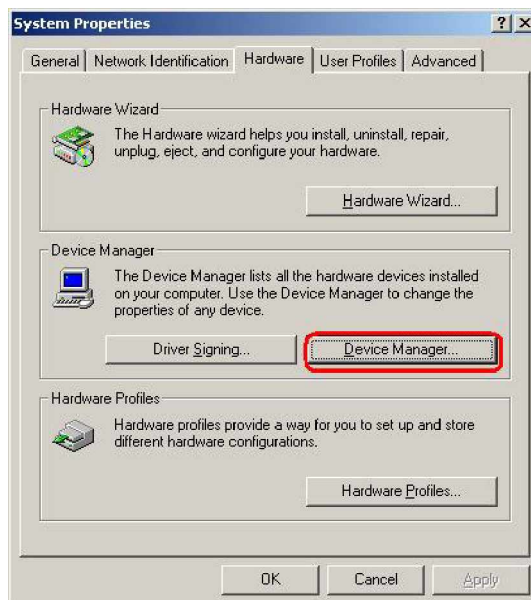

Figure 6-15: Double Click the Device Manager Tab

Step 4: A list of system hardware devices appears (Figure 6-16).

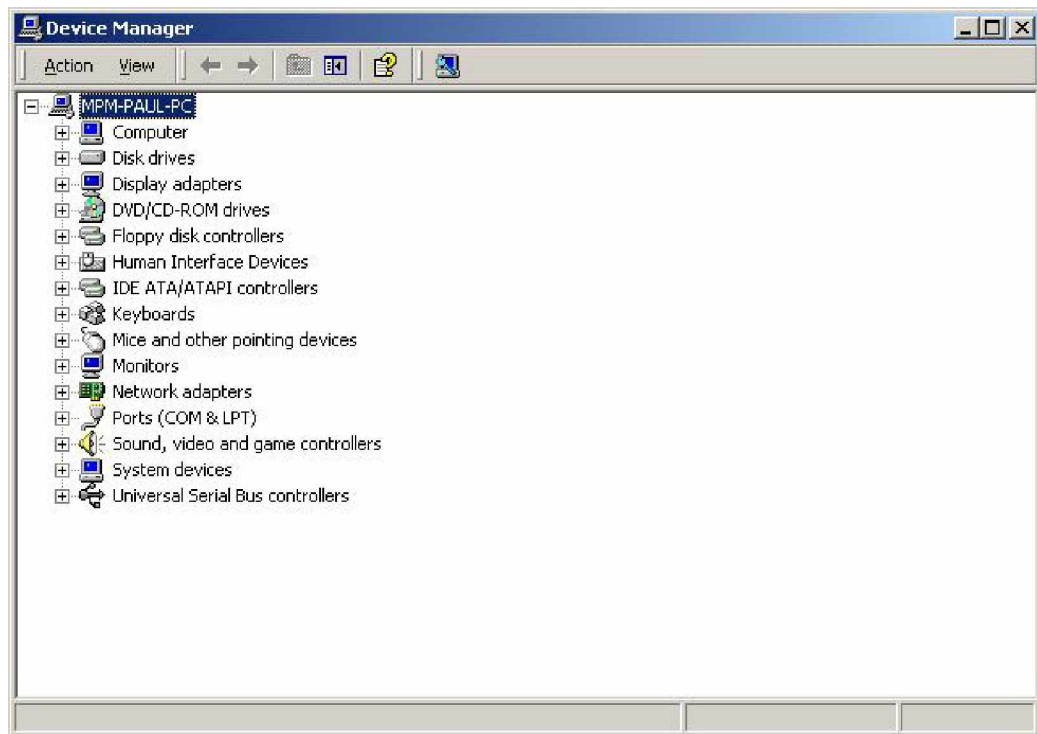

Figure 6-16: Device Manager List

- Step 5:** Double click the listed device that has question marks next to it. (This means Windows does not recognize the device).
- Step 6:** The **Device Driver Wizard** appears (**Figure 6-17**). Click **NEXT** to continue.



Figure 6-17: Search for Suitable Driver

Step 7: Select “Specify a Location” in the **Locate Driver Files** window (Figure 6-18).

Click **NEXT** to continue.



Figure 6-18: Locate Driver Files

Step 8: Select "X:\Audio\GeodeLX_XP_XPe_WDM_Audio_v2.03.00" directory in the location browsing window, where "X:\" is the system CD drive (**Figure 6-19**).

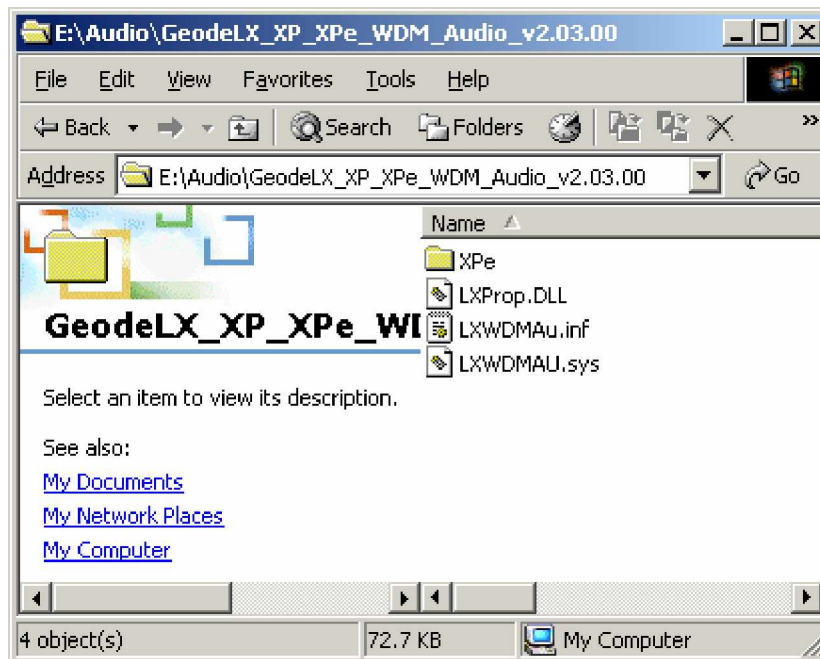

Figure 6-19: Location Browsing Window

Step 9: Click **OK** to continue. A driver files location menu window appears. Select the **LXWDMAu.inf** file and click **OPEN** to continue. The driver is installed.

6.4 LAN Driver

To install the LAN driver, please follow the steps below.

Step 1: Click **LAN** from the **AMD LX/GX CD Driver Menu** to open a window to the **X:\LAN\Realtek** (where X:\ is the system CD drive) folder on the driver CD.

Step 2: Open the **RTL8100C** folder.

Step 3: Locate the **Setup** program icon (**Figure 6-20**).

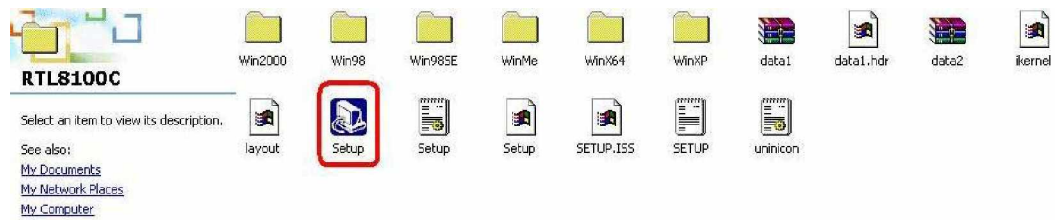

Figure 6-20: Locate the Setup Program Icon

Step 4: Double click the **Setup** program icon in **Figure 6-20**.

Step 5: The **Install Shield Wizard** is prepared to guide the user through the rest of the process (**Figure 6-21**).

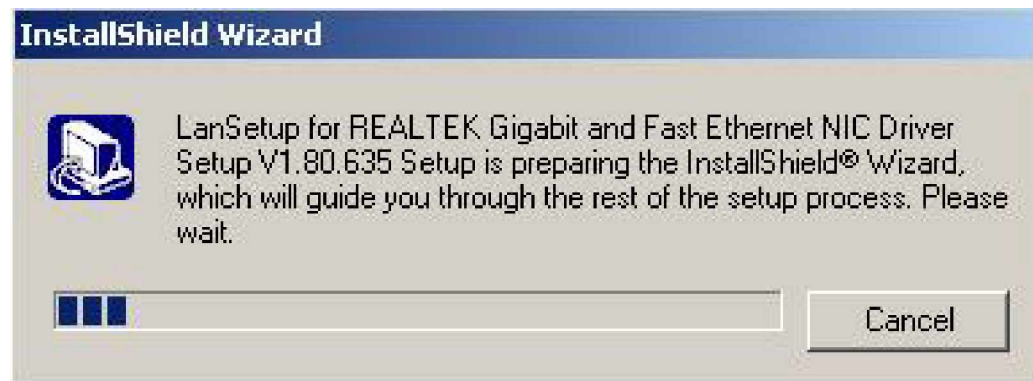

Figure 6-21: Preparing Setup Screen

Step 6: Once initialized, the **Install Wizard** welcome screen appears (**Figure 6-22**).

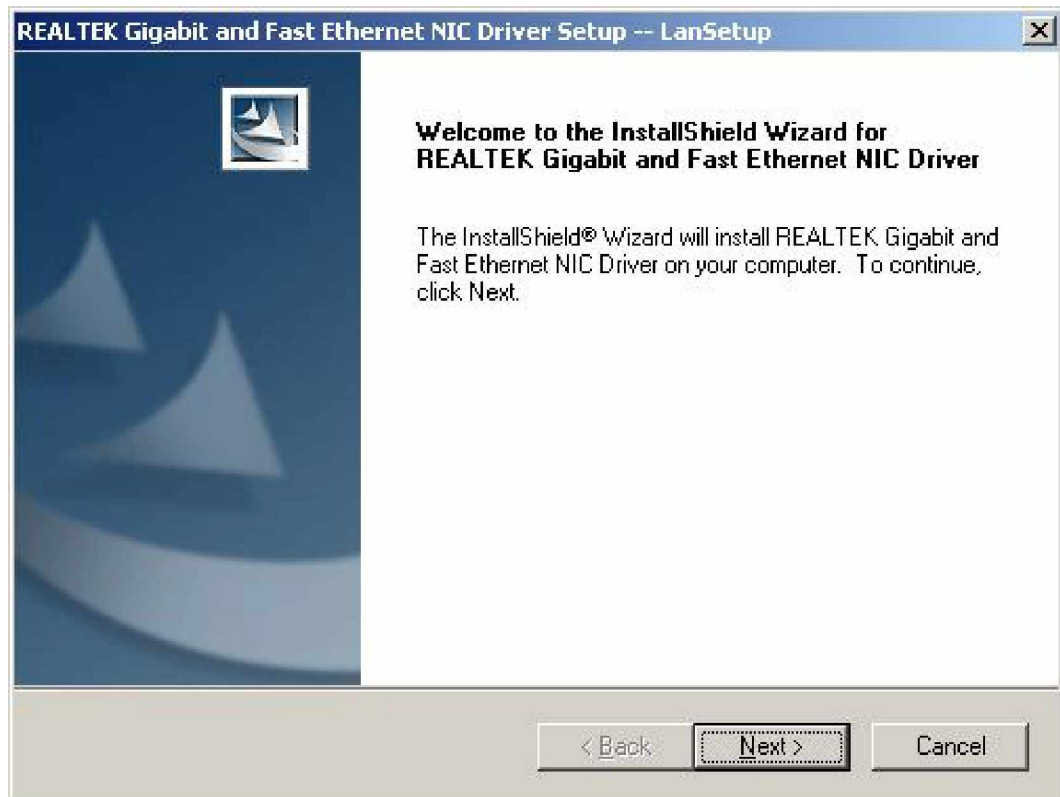

Figure 6-22: Install Wizard Welcome Screen

- Step 7:** Click **NEXT** to continue the installation or **CANCEL** to stop the installation.
- Step 8:** The **Install Wizard** starts to install the LAN driver.
- Step 9:** Once the installation is complete, the **InstallShield Wizard Complete** screen appears (**Figure 6-23**).

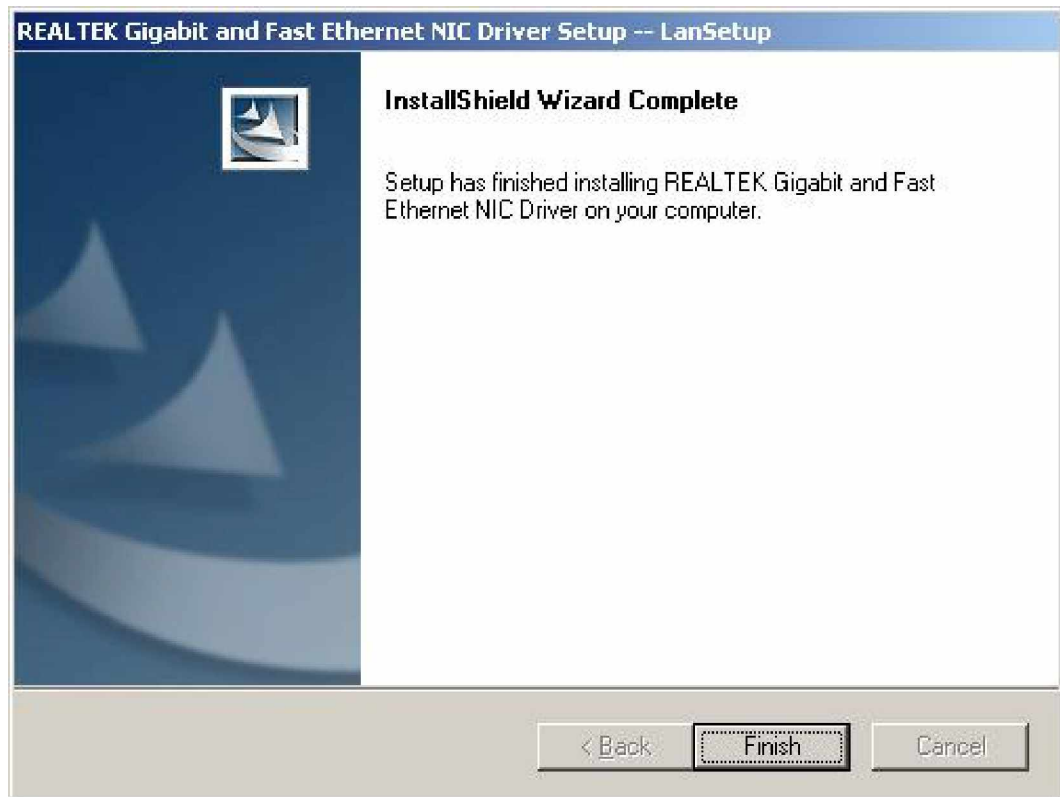

Figure 6-23: Installing Screen

Step 10: Click **FINISH** to complete the installation and exit the **Install Shield Wizard**.

Step 11: Once the installation process is complete, the computer may be restarted immediately or later. Select the preferred option and click **FINISH** to complete the installation process and exit the **Install Shield Wizard (Figure 6-24)**.



Figure 6-24: Restart the Computer

6.5 SATA/RAID Driver

To install the ALi SATA/RAID driver, please follow the steps below.

Step 1: Click **SATA** from the **AMD LX/GX CD Driver Menu** to open a window to the **X:\ALi_SATA_M5283** (where X:\ is the system CD drive) folder on the driver CD.

Step 2: Locate the **Setup** program icon (**Figure 6-25**).

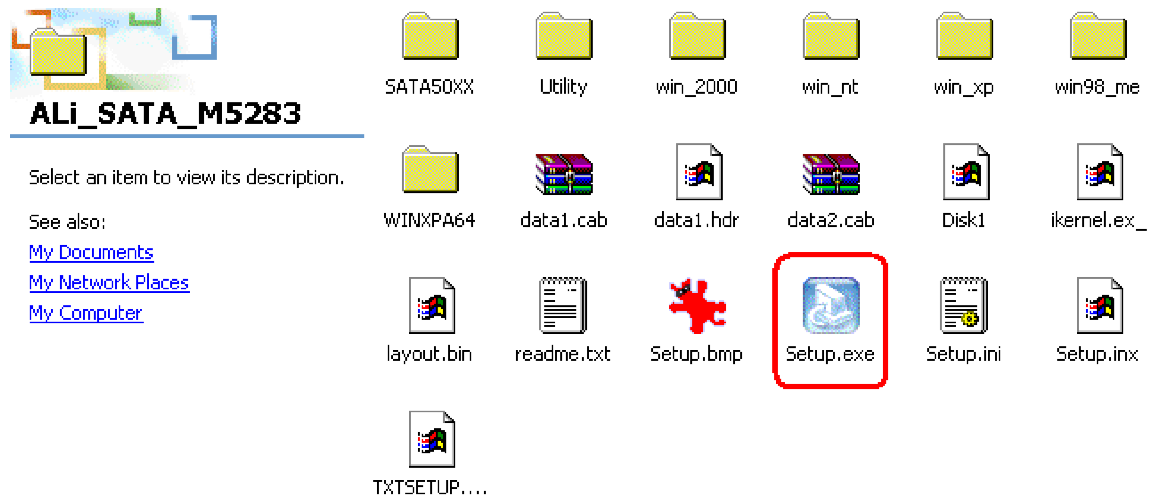

Figure 6-25: Locate the Setup Program Icon

Step 3: The **Install Shield Wizard** (Figure 6-26) is prepared to guide the user through the rest of the process.

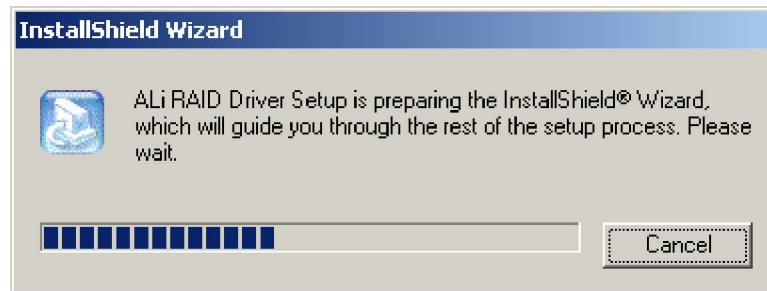

Figure 6-26: Preparing Setup Screen

Step 4: Once initialized, the **Install Wizard** welcome screen appears (Figure 6-27).

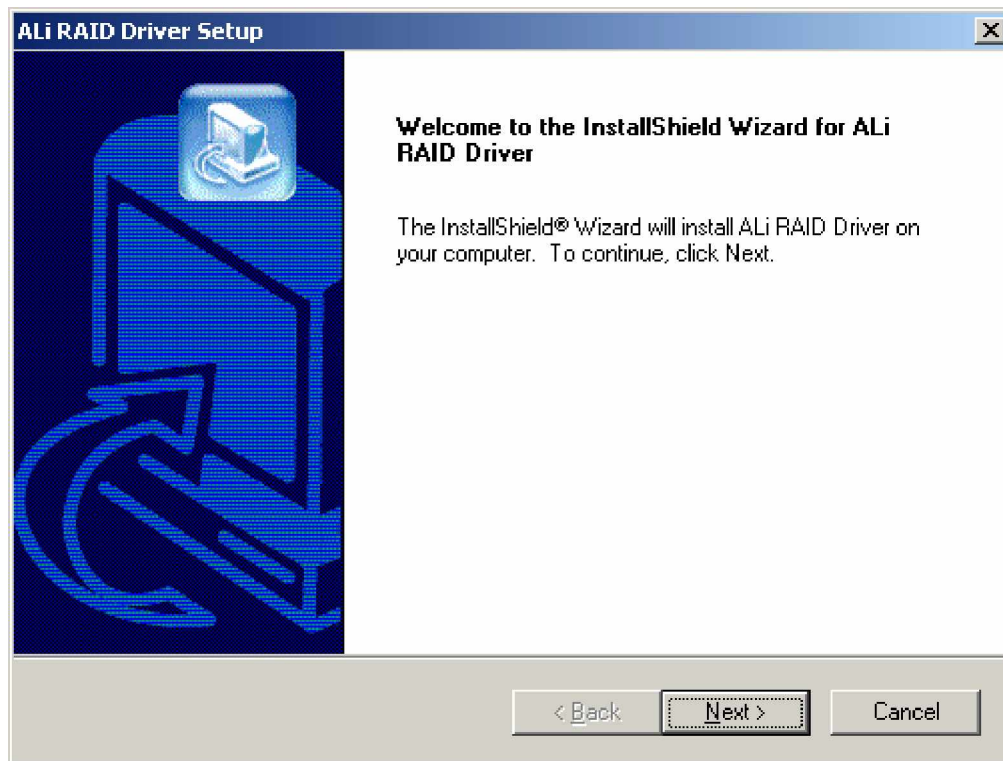

Figure 6-27: Install Wizard Welcome Screen

Step 5: Click **NEXT** to continue the installation or **CANCEL** to stop the installation.

Step 6: The **Install Wizard** starts to install the driver (**Figure 6-28**).

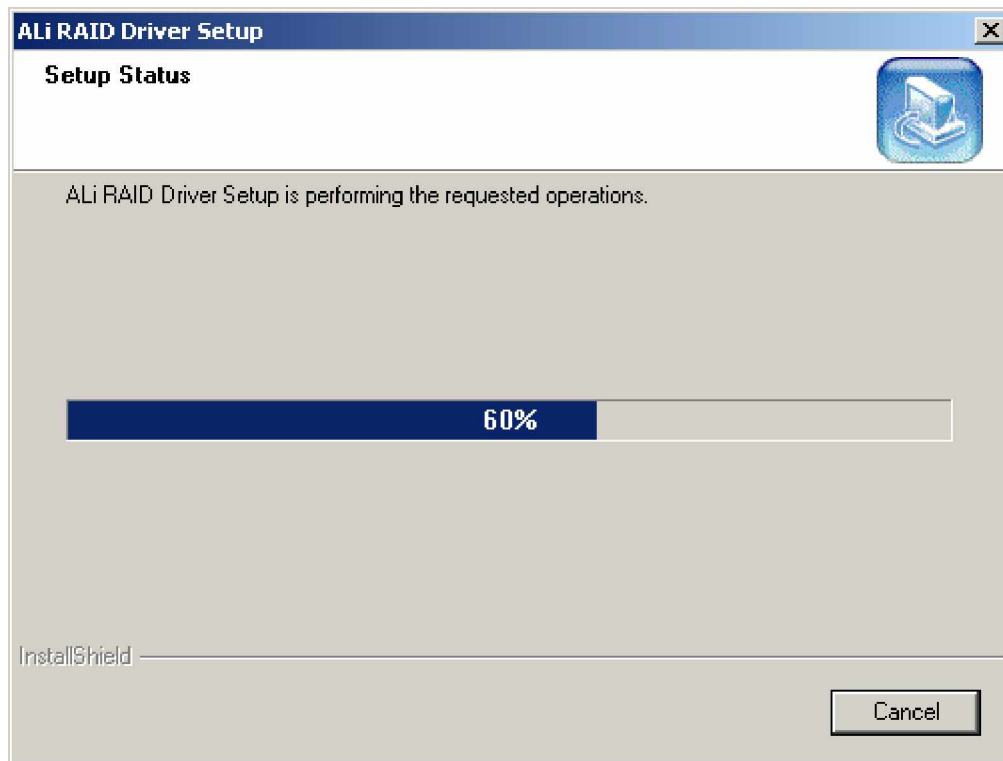

Figure 6-28: Installing Screen

Step 7: A "Digital Signal Not Found" screen appears (Figure 6-29). Click YES to continue the installation process.

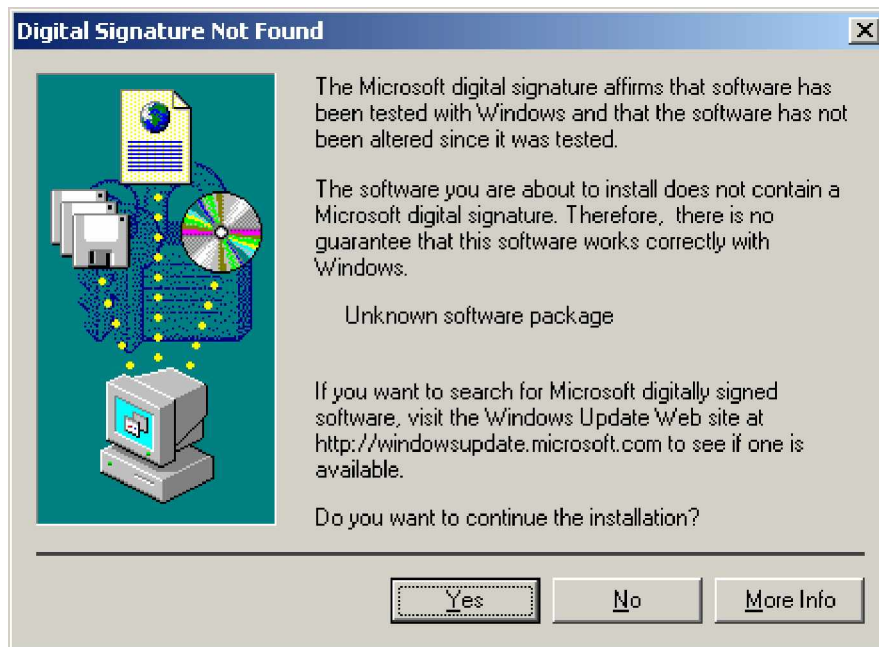

Figure 6-29: RAID Driver Digital Signal

Step 8: Once the installation is complete, the **InstallShield Wizard Complete** screen appears (**Figure 6-30**).

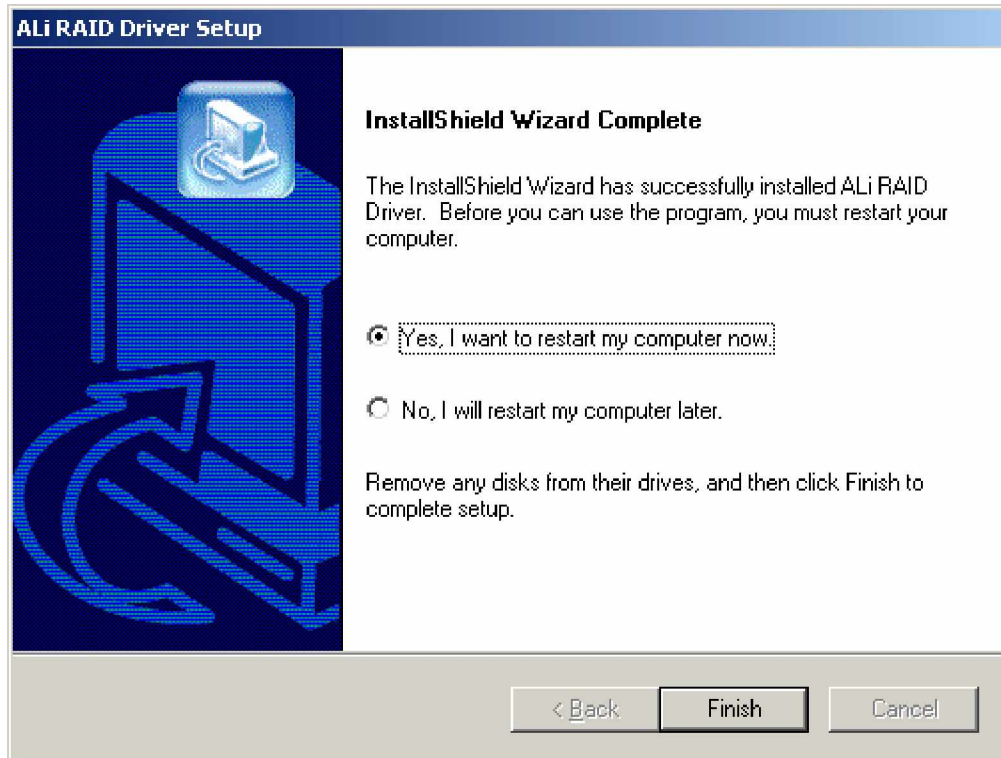

Figure 6-30: InstallShield Wizard Complete Screen

Step 9: Once the installation process is complete, the computer may be restarted immediately or later. Select the preferred option and click **FINISH** to complete the installation process and exit the **Install Shield Wizard**.

6.6 ISA Driver

To install the IT8888 ISA Bridge driver please follow the steps below:

Step 1: Open **Windows Control Panel** (Figure 6-31).

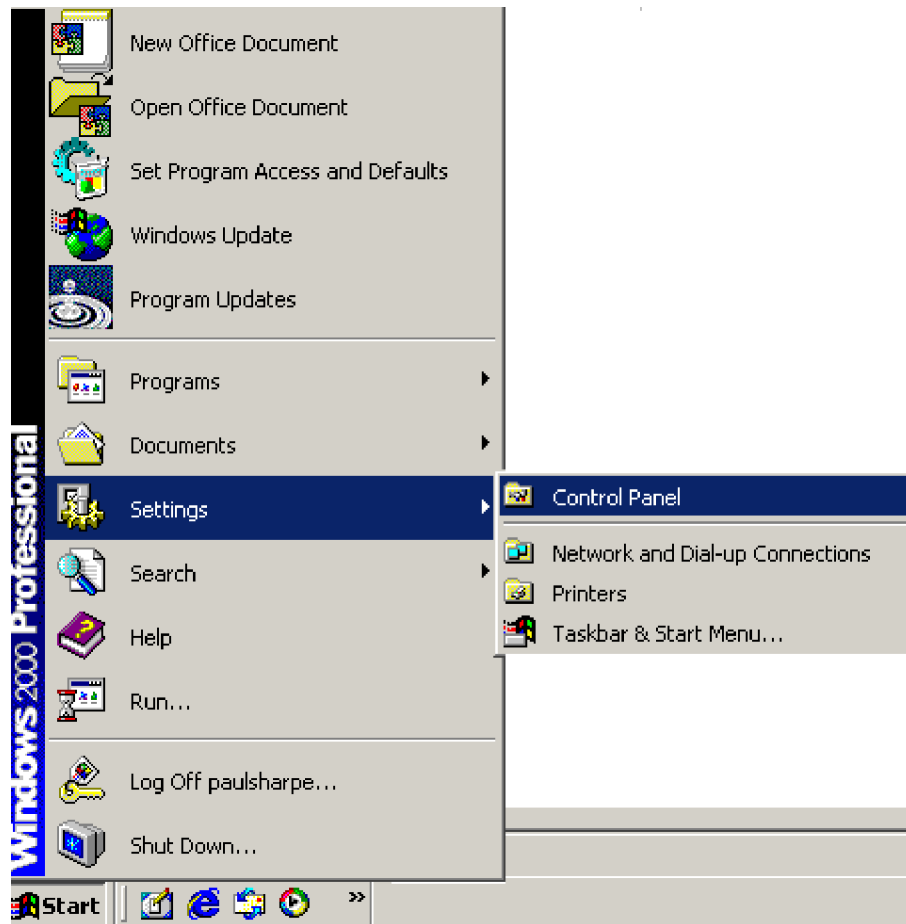

Figure 6-31: Access Windows Control Panel

Step 2: Double click the **System** icon (Figure 6-32).

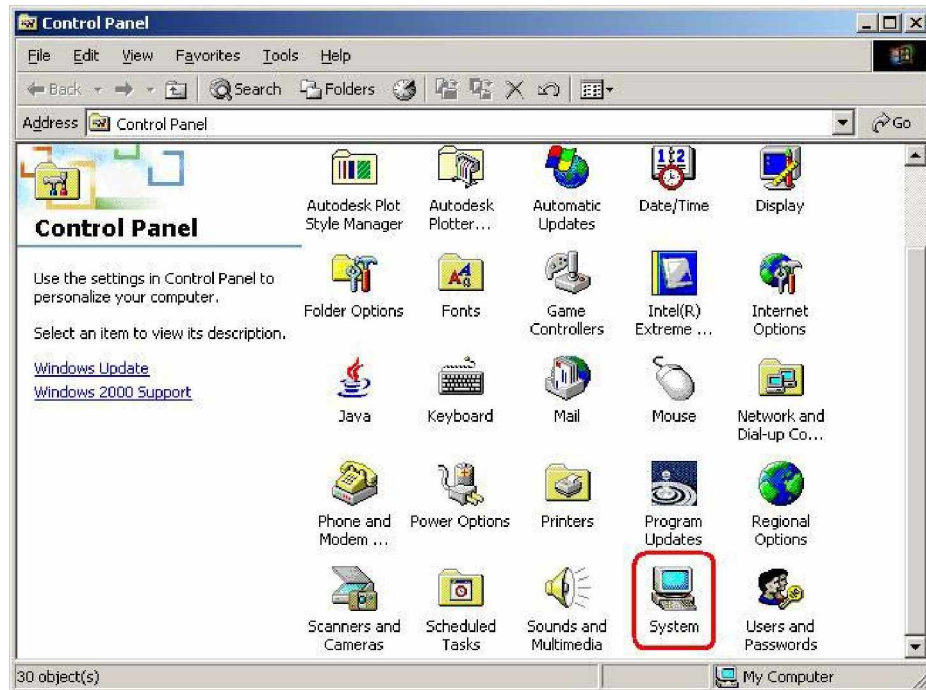

Figure 6-32: Double Click the System Icon

Step 3: Double click the **Device Manager** tab (**Figure 6-33**).

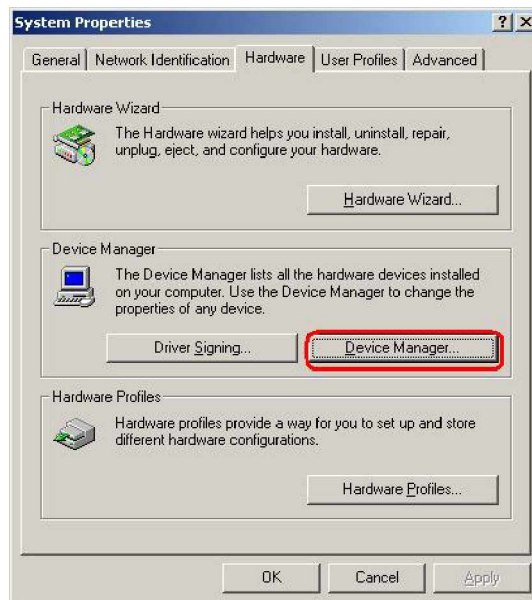

Figure 6-33: Double Click the Device Manager Tab

Step 4: A list of system hardware devices appears (**Figure 6-34**).

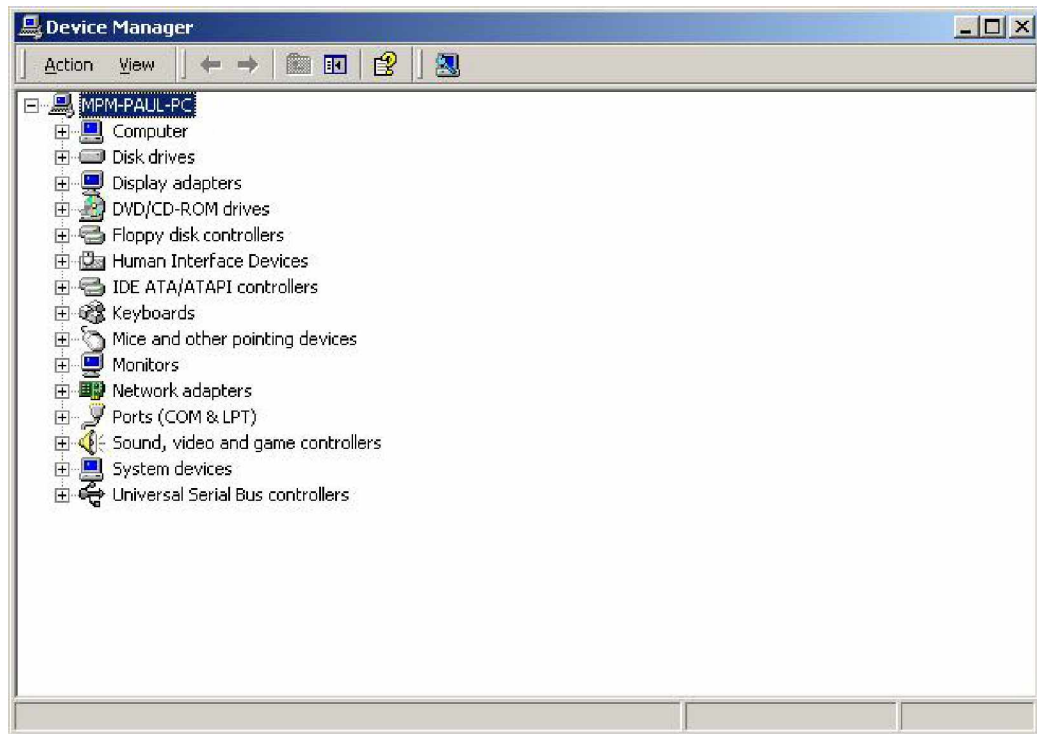

Figure 6-34: Device Manager List

Step 5: Double click the listed device that has question marks next to it. (This means Windows does not recognize the device).

Step 6: The **Device Driver Wizard** appears (**Figure 6-35**). Click **NEXT** to continue.



Figure 6-35: Search for Suitable Driver

- Step 7:** Select “Specify a Location” in the **Locate Driver Files** window (Figure 6-36).
Click **NEXT** to continue.



Figure 6-36: Locate Driver Files

Step 8: Select "X:\IT8888" directory in the location browsing window, where "X:\:" is the system CD drive (**Figure 6-37**).

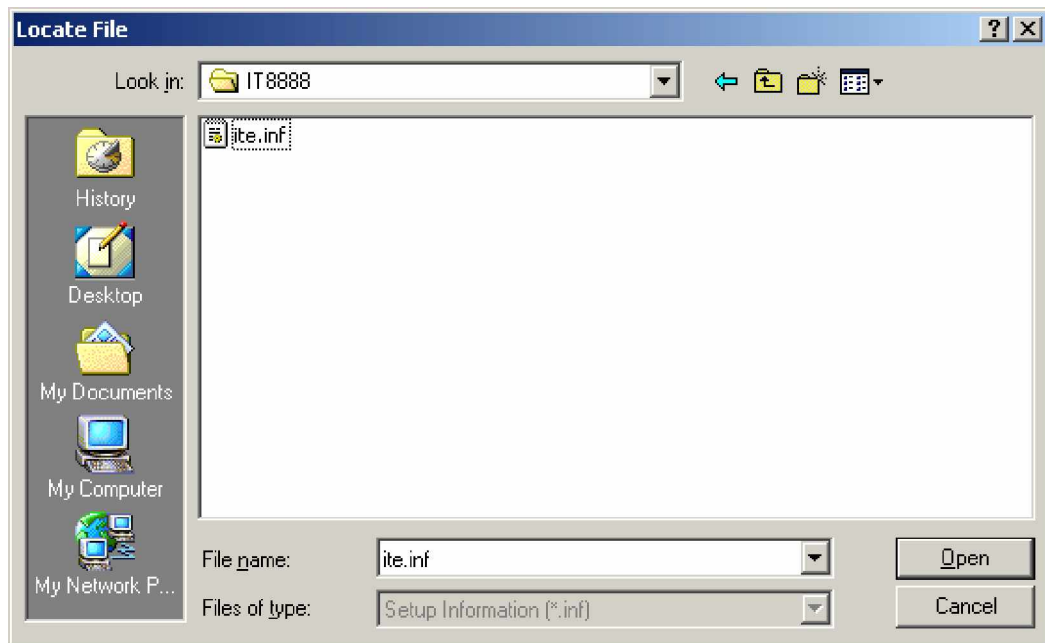

Figure 6-37: Location Browsing Window

Step 9: Click **OK** to continue. A driver files location menu window appears. Select the **ite.inf** file and click **OPEN** to continue. The driver is installed.

Appendix

A

BIOS Options

⌈ Load Fail-Safe Defaults	82
⌈ Load Optimized Defaults.....	83
⌈ Set Supervisor Password	83
⌈ Set User Password	83
⌈ Save & Exit Setup	83
⌈ Exit Without Saving	83
⌈ Date [Day mm:dd:yyyy].....	84
⌈ Time [hh/mm/ss]	84
⌈ IDE Master and IDE Slave	84
⌈ Drive A/B [None]	85
⌈ Video	85
⌈ Halt On [All, But Keyboard]	85
⌈ Base Memory:	86
⌈ Extended Memory	86
⌈ Total Memory	86
⌈ IDE HDD Auto-Detection [Press Enter].....	87
⌈ IDE Primary Master [Auto]	87
⌈ Access Mode [Auto]	88
⌈ Capacity	88
⌈ Cylinder	89
⌈ Head	89
⌈ Precomp	89
⌈ Landing Zone	89
⌈ Sector	89
⌈ Virus Warning [Disabled]	90
⌈ CPU Internal Cache [Enabled].....	91
⌈ Quick Power On Self Test [Enabled]	91
⌈ Boot From LAN Control [Disabled].....	91
⌈ SATA Boot ROM Control [Disabled]	92
⌈ Boot Device	92
⌈ Boot Other Device [Enabled].....	93

⌈ Swap Floppy Drive [Disabled]	93
⌈ Boot Up Floppy Seek [Disabled]	93
⌈ Boot Up Numlock Status [On]	94
⌈ Gate A20 Option [Fast]	94
⌈ Typematic Rate Setting [Disabled]	94
⌈ Typematic Rate (Chars/sec) [6]	95
⌈ Typematic Delay (Msec) [250]	95
⌈ Security Option [Setup]	96
⌈ OS Select For DRAM > 64MB [Non-OS2]	96
⌈ Video BIOS Shadow [Enabled]	96
⌈ XXXXX-YYYYY Shadow [Disabled]	97
⌈ Small Logo (EPA) Show [Disabled]	97
⌈ Cyrix 6x86/MII CPUID [Enabled]	97
⌈ CPU Frequency [200/133/33]	98
⌈ Video Memory Size [8M]	98
⌈ Flat Panel Configuration [Press Enter]	99
⌈ OnBoard Audio [Enabled]	99
⌈ Onboard USB1.1 [Enabled]	99
⌈ Onboard USB2.0 [Enabled]	99
⌈ UART Port A [Disabled]	99
⌈ Flat Panel Type [Auto]	100
⌈ Resolution [640 x 480]	100
⌈ Bus Width [8 Bit]	101
⌈ Data Type [Normal]	101
⌈ Refresh Rate [60Hz]	101
⌈ HSYNC Polarity [Low]	102
⌈ VSYNC Polarity Active [Low]	102
⌈ SHFCLK Active Period [Free Running]	102
⌈ LP Active Period [Free Running]	102
⌈ On-Chip IDE Channel 0/1 [Enabled]	104
⌈ Drive PIO Mode [Auto]	104
⌈ IDE UDMA [Auto]	104

⌈ IDE DMA transfer access [Enabled].....	105
⌈ IT8888 ISA Decode IO [Press Enter]	105
⌈ IT8888 ISA Decode Memory [Press Enter]	105
⌈ IDE HDD Block Mode [Enabled]	105
⌈ Onboard FDC Controller [Enabled].....	105
⌈ Onboard Serial Port 1 [3F8/IRQ4].....	106
⌈ Onboard Serial Port 2 [2F8/IRQ3].....	106
⌈ UART Mode Select [Normal]	106
⌈ x RxD, TxD Active [Hi,Lo].....	107
⌈ x IR Transmission Delay [Enabled].....	107
⌈ x UR2 Duplex Mode [Half]	107
⌈ x Use IR Pins [IR-Rx2Tx2].....	107
⌈ Onboard Parallel Port [378/IRQ7].....	108
⌈ Parallel Port Mode [SPP].....	108
⌈ x EPP Mode Select [EPP1.7]	109
⌈ x ECP Mode Use DMA [3]	109
⌈ Decode IO Space N [Enabled]	112
⌈ Decode IO Speed N [Fast Speed].....	112
⌈ Decode IO Address N 0:15 [xx]	112
⌈ Decode IO Size N [Fast Speed].....	112
⌈ Decode Memory Space N [Enabled]	114
⌈ Decode Memory Speed N [Fast Speed].....	115
⌈ Decode Memory Address N [xx].....	115
⌈ Decode Memory Size N [xx].....	115
⌈ ACPI Function [Disabled].....	116
⌈ Power Management [ACPI]	116
⌈ x Standby Mode [Disabled].....	117
⌈ x Suspend Mode [Disabled].....	117
⌈ Modem Use of IRQ [N/A]	118
⌈ Power-On by Alarm [Disabled].....	118
⌈ RTC Alarm Date (Days)	119
⌈ System Time	119

⌈ IRQ Wakeup Events [Press Enter]	119
⌈ PNP OS Installed [No]	120
⌈ Init. Display First [Onboard]	121
⌈ Reset Configuration Data [Disabled]	121
⌈ Resources Controlled By [Auto (ESCD)].....	121
⌈ x IRQ Resources [Press Enter].....	121
⌈ x Memory Resources [Press Enter]	123
⌈ Reserved Memory Base [N/A].....	123
⌈ x Reserved Memory Length [8K].....	124
⌈ PCI/VGA Palette Snoop [Disabled].....	124
⌈ Assign IRQ for USB [Enabled].....	124
⌈ Shutdown Temperature [Disabled]	125
⌈ CPU Warning Temperature [Disabled].....	126
⌈ System Temperature	126
⌈ Voltages	126

THIS PAGE IS INTENTIONALLY LEFT BLANK

Appendix

B

DIO Connector

B.1 DIO Interface Introduction

The DIO connector on the 3302040 is interfaced to GIO ports on the Winbond W83627EHG Super I/O chipset. The DIO has both 4-bit digital inputs and 4-bit digital outputs. The digital inputs and digital outputs are generally control signals that control the on/off circuit of external devices or TTL devices. Data can be read or written to the selected address to enable the DIO functions.



NOTE:

For further information, please refer to the Winbond datasheet for the Winbond W83627EHG Super I/O chipset.

B.2 DIO Connector Pinouts

The following table describes how the DIO connector pins are connected to the Super I/O GPIO port 1.

Pin No	Description	Super I/O Pin	Super I/O Pin Description
1	Ground	N/A	N/A
2	VCC	N/A	N/A
3	Output 0	GP14	General purpose I/O port 1 bit 4.
4	Output 1	GP15	General purpose I/O port 1 bit 5.
5	Output 2	GP16	General purpose I/O port 1 bit 6.
6	Output 3	GP17	General purpose I/O port 1 bit 7.
7	Input 0	GP10	General purpose I/O port 1 bit 0.
8	Input 1	GP11	General purpose I/O port 1 bit 1
9	Input 2	GP12	General purpose I/O port 1 bit 2
10	Input 3	GP13	General purpose I/O port 1 bit 3

B.3 Assembly Language Samples

B.3.1 Enable the DIO Input Function

The BIOS interrupt call INT 15H controls the digital I/O. An assembly program to enable digital I/O input functions is listed below.

MOV	AX, 6F08H	Sets the digital port as input
INT	15H	Initiates the INT 15H BIOS call

B.3.2 Enable the DIO Output Function

The BIOS interrupt call INT 15H controls the digital I/O. An assembly program to enable digital I/O output functions is listed below.

MOV	AX, 6F09H	Sets the digital port as output
MOV	BL, 09H	
INT	15H	Initiates the INT 15H BIOS call

THIS PAGE IS INTENTIONALLY LEFT BLANK

Appendix

C

Watchdog Timer

**NOTE:**

The following discussion applies to DOS environment. Global American, Inc support is contacted or the Global American, Inc website visited for specific drivers for more sophisticated operating systems, e.g., Windows and Linux.

The Watchdog Timer is provided to ensure that standalone systems can always recover from catastrophic conditions that cause the CPU to crash. This condition may have occurred by external EMI or a software bug. When the CPU stops working correctly, Watchdog Timer either performs a hardware reset (cold boot) or a Non-Maskable Interrupt (NMI) to bring the system back to a known state.

A BIOS function call (INT 15H) is used to control the Watchdog Timer:

INT 15H:

AH – 6FH Sub-function:	
AL – 2:	Sets the Watchdog Timer's period.
BL:	Time-out value (Its unit-second is dependent on the item "Watchdog Timer unit select" in CMOS setup).

Table C-1: AH-6FH Sub-function

Call sub-function 2 to set the time-out period of Watchdog Timer first. If the time-out value is not zero, the Watchdog Timer starts counting down. While the timer value reaches zero, the system resets. To ensure that this reset condition does not occur, calling sub-function 2 must periodically refresh the Watchdog Timer. However, the Watchdog timer is disabled if the time-out value is set to zero.

A tolerance of at least 10% must be maintained to avoid unknown routines within the operating system (DOS), such as disk I/O that can be very time-consuming.

**NOTE:**

When exiting a program it is necessary to disable the Watchdog Timer, otherwise the system resets.

Example program:

```
; INITIAL TIMER PERIOD COUNTER
;
W_LOOP:

    MOV     AX, 6F02H      ;setting the time-out value
    MOV     BL, 30        ;time-out value is 48 seconds
    INT     15H

;
; ADD THE APPLICATION PROGRAM HERE
;

    CMP     EXIT_AP, 1    ;is the application over?
    JNE     W_LOOP       ;No, restart the application

    MOV     AX, 6F02H    ;disable Watchdog Timer
    MOV     BL, 0        ;
    INT     15H

;
; EXIT ;
```

THIS PAGE IS INTENTIONALLY LEFT BLANK

Appendix

D

Address Mapping

D.1 Address Map

I/O address Range	Description
000-01F	DMA Controller
020-021	Interrupt Controller
040-043	System time
060-06F	Keyboard Controller
070-07F	System CMOS/Real time Clock
080-09F	DMA Controller
0A0-0A1	Interrupt Controller
0C0-0DF	DMA Controller
0F0-0FF	Numeric data processor
1F0-1F7	Primary IDE Channel
2F8-2FF	Serial Port 2 (COM2)
378-37F	Parallel Printer Port 1 (LPT1)
3B0-3BB	Graphics Controller
3C0-3DF	Graphics Controller
3F6-3F6	Primary IDE Channel
3F7-3F7	Standard floppy disk controller
3F8-3FF	Serial Port 1 (COM1)

Table D-1: IO Address Map

D.2 1st MB Memory Address Map

Memory address	Description
00000-9FFFF	System memory
A0000-BFFFF	VGA buffer
F0000-FFFFFF	System BIOS
1000000-	Extend BIOS

Table D-2: 1st MB Memory Address Map

D.3 IRQ Mapping Table

IRQ0	System Timer	IRQ8	RTC clock
IRQ1	Keyboard	IRQ9	ACPI
IRQ2	Available	IRQ10	LAN
IRQ3	COM2	IRQ11	LAN/USB2.0/SATA
IRQ4	COM1	IRQ12	PS/2 mouse
IRQ5	SMBus Controller	IRQ13	FPU
IRQ6	FDC	IRQ14	Primary IDE
IRQ7	Available	IRQ15	Secondary IDE

Table D-3: IRQ Mapping Table

D.4 DMA Channel Assignments

Channel	Function
0	Available
1	Available
2	Floppy disk (8-bit transfer)
3	Available
4	Cascade for DMA controller 1
5	Available
6	Available
7	Available

Table D-4: IRQ Mapping Table

THIS PAGE IS INTENTIONALLY LEFT BLANK

Appendix

E

External AC'97 Audio CODEC

E.1 Introduction

The motherboard comes with an on-board Realtek ALC655 CODEC. Realtek ALC655 is a 16-bit, full duplex AC'97 Rev. 2.3 compatible audio CODEC with a sampling rate of 48KHz.

E.1.1 Accessing the AC'97 CODEC

The CODEC is accessed through a connector on the 3302040 motherboard. Connect the audio kit to the connector.

E.1.2 Driver Installation

The driver installation has been described in **Chapter 6**.

After rebooting the sound effect configuration utility appears in the Windows Control Panel (see **Figure E-1**). If the peripheral speakers are properly connected, sound effects should be heard.

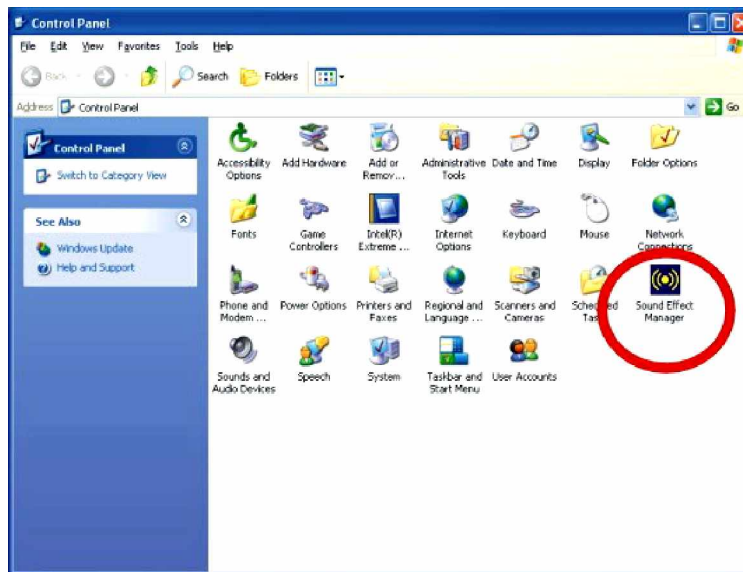

Figure E-1: Sound Effect Manager Control Panel

E.2 Sound Effect Configuration

E.2.1 Accessing the Sound Effects Manager

To access the **Sound Effects Manager**, please do the following:

Step 1: Install the audio CODEC driver.

Step 2: Click either:

- „ The Sound Effect Manager icon in the Notification Area of the system task bar (see **Figure E-2**), or
- „ The Sound Effect Manager icon in the Control Panel (**Figure E-3**).

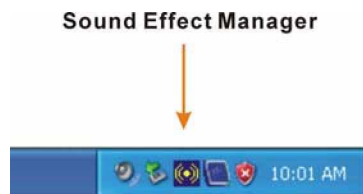

Figure E-2: Sound Effect Manager Icon [Task Bar]

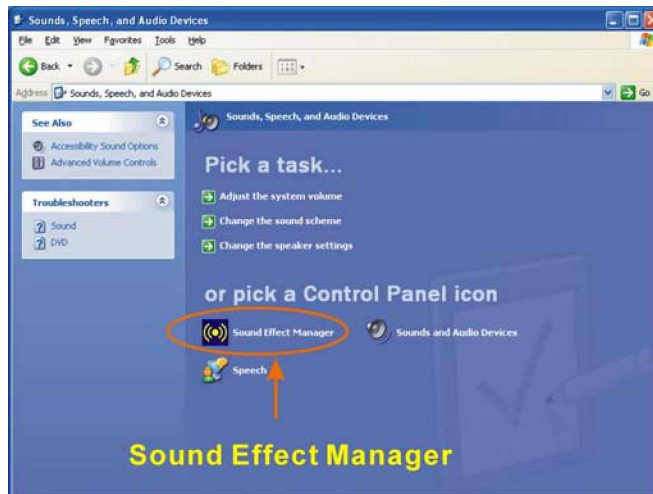

Figure E-3: Sound Effect Manager Icon [Control Panel]

Step 3: The sound effect manager appears. (See **Figure E-4**)

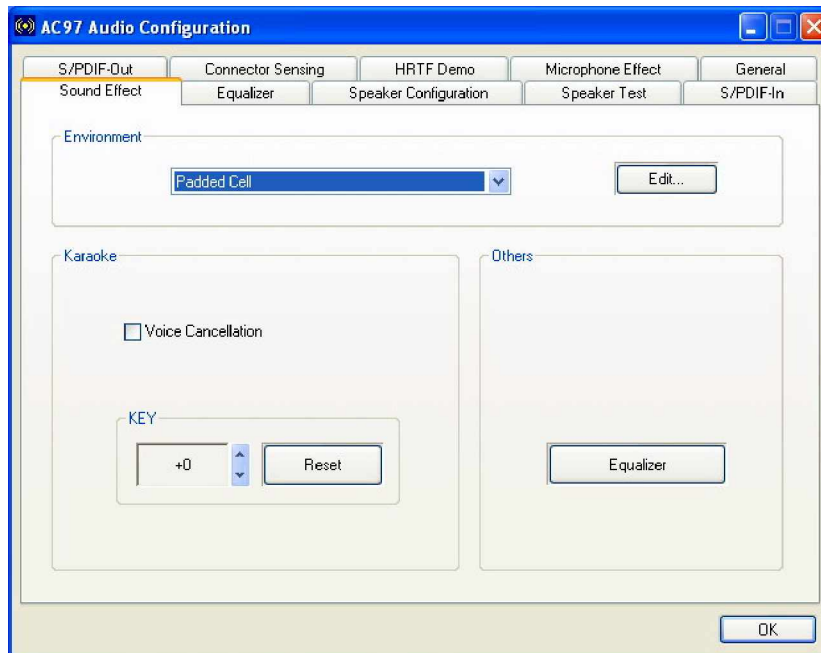

Figure E-4: Sound Effects Manager (ALC655)



NOTE:

The Sound Effect Manager shown in Error! Reference source not found. is for the RealTek ALC655 audio CODEC. Different CODECs may have different sound manager appearances.

The following section describes the different configuration options in the Sound Effect Manager.

E.2.2 Sound Effect Manager Configuration Options

The **Sound Effects Manager** enables configuration of the items listed below. To configure these items click the corresponding menu tab in the **Sound Effects Manager**.

**NOTE:**

The **Karaoke Mode** is configured in the **Sound Effect** menu. To access Karaoke configuration settings, click on the **Sound Effect** menu tab.

- „ Sound Effect
 - „ Karaoke Mode
 - „ Equalizer
 - „ Speaker Configuration
 - „ Speaker Test
 - „ S/PDIF-In
 - „ S/PDIF-Out
 - „ Connector Sensing
 - „ HRTF Demo
 - „ Microphone Effect
 - „ General
-

**NOTE:**

Not all RealTek **Sound Effect Managers** have all the above listed options. The Sound Effect Manager loaded onto the system may only have some of the options listed above.

Below is a brief description of the available configuration options in the **Sound Effects Manager**.

- „ **Sound Effect**:- Select a sound effect from the 23 listed options in the drop down menu. Selected sound effect properties can be edited. To edit the sound effect click “**EDIT**.”
- „ **Karaoke Mode**:- The **Karaoke Mode** is accessed in the Sound Effect window. The **Voice Cancellation** disables the vocal part of the music being played.

The **Key adjustment** up or down arrow icons enables users to define a key that fits a certain vocal range.

- „ **Equalizer Selection:**- Preset equalizer settings enable easy audio range settings. Ten frequency bands can be configured.

- „ **Speaker Configuration:**- Multi-channel speaker settings are configured in this menu. Configurable options include:
 - Headphone
 - Channel mode for stereo speaker output
 - Channel mode for 4 speaker output
 - Channel mode for 5.1 speaker output
 - Synchronize the phonejack switch with speakers settings

- „ **Speaker Test:**- Each speaker connected to the system is tested individually to see if the 4-channel or 6-channel audio operates properly.

- „ **S/PDIF-In & S/PDIF-Out:**- These functions are currently not supported.

- „ **Connector Sensing:**- Realtek ALC655 detects if an audio device is plugged into the wrong connector. If an incorrect device is plugged in a warning message appears.

- „ **HRTF Demo:**- Adjust HRTF (Head Related Transfer Functions) 3D positional audio here before running 3D applications.

- „ **Microphone Effect:**- Microphone noise suppression is enabled in this menu.

- „ **General:**- General information about the installed AC'97 audio configuration utility is listed here.

Appendix

E

Ai RAID

F.1 Introduction

The ALi M5283 SATA RAID chipset can control parallel ATA (PATA) and serial ATA (SATA) disks. The ALi controller supports PATA UDMA transfer mode up to mode 6 and SATA 1 disk drives. The ALi M5283 also has a cost-effective RAID functionality that can increase the data read/write speed and provide protection to data by distributing mirrored duplicates of data onto two disk drives (RAID 1).



CAUTION!

A configured RAID volume (which may consist of multiple hard drives) appears to an operating system as a contingent storage space. The operating system will not be able to distinguish the physical disk drives contained in a RAID configuration.

F.1.1 Precautions

One key benefit a RAID configuration brings is that a single hard drive can fail within a RAID array without damaging data. With RAID1 array, a failed drive can be replaced and the RAID configuration restored.



WARNING!

Irrecoverable data loss occurs if a working drive is removed when trying to remove a failed drive. It is strongly recommended to mark the physical connections of all SATA disk drives. Drive locations can be identified by attaching stickers to the drive bays. If a drive member of a RAID array should fail, the failed drive can then be correctly identified.



CAUTION!

Do not accidentally disconnect the SATA drive cables. Carefully route the cables within the chassis to avoid system down time.

F.2 Features and Benefits

- „ Supports RAID levels 0, 1, and JBOD
- „ Supports connectivity to two disk drives
- „ Supported Operating Systems include: Windows 98/Me, Windows 2000 and Windows XP
- „ Windows-based software for RAID management

F.3 Accessing the ALi RAID Utility

To access the **Ali RAID Utility**, please follow the steps below:

Step 4: Connect SATA drives to the system. Connect two SATA drives to the system. Make sure the drives have the same capacity, are the same type and have the same speed.



NOTE:

Make sure the SATA drives are EXACTLY the same when they are configured in a RAID configuration (JBOD, RAID 0 or RAID 1). If they are not the same size, disk drive capacity is sacrificed and overall performance affected.

Step 5: Enable SATA drives in BIOS. Start the computer and access the **AMI BIOS** setup program. Next, open the **Advanced CMOS Setup** menu. Enable the **SATA ROM Support BIOS** option. (See **Section** Error! Reference source not found.)

Step 6: Save and Exit BIOS. After the **SATA ROM Support BIOS** option is enabled, save and exit the **BIOS**.

Step 7: **Reboot the system.** Reboot the system after saving and exiting the **BIOS**.

Step 8: **Press Ctrl-A.** When the screen in **FigureF-1** appears press **Ctrl-A** to enter the **ALi RAID BIOS** setup program.

```
ALi RAID BIOS V1.XX
(c) ALi Corporation 2005, All Rights Reserved.
Identifying IDE drives...

Channel 1 Master: None
Channel 1 Slave: None
Channel 2 Master: [Drive Brand Name] [Drive ID number] SATA 1 [Drive Capacity]
Channel 3 Master: [Drive Brand Name] [Drive ID number] SATA 1 [Drive Capacity]

Press Ctrl-A to enter ALi RAID BIOS setup utility
```

Figure : **Accessing ALi RAID BIOS Utility**

Step 9: **Delete RAID settings and partitions.** The **RAID BIOS Setup Utility** in **FigureF-2** appears. Before configuring the array select the “**Delete All RAID Setting & Partition**”.

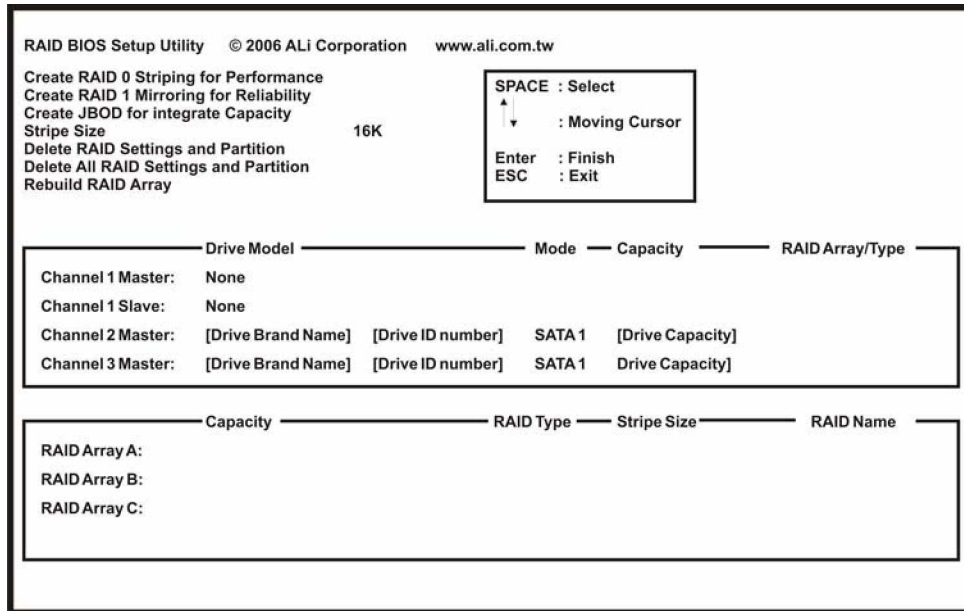

Figure F-2: RAID BIOS Setup Utility

Step 10: Configure the RAID settings. Use the RAID BIOS Setup Utility in Error!

Reference source not found. to configure the RAID array. Brief descriptions are given below.

Step 11: Install the OS. After the RAID array has been configured (see below) install the OS. To do this, please refer to the documentation that came with the OS.

F.4 RAID Options:

F.4.1 Create RAID 0 Striping for Performance



WARNING!

All data previously stored on the member drives of a RAID configuration **are**

destroyed during the RAID initialization process. If “used” drives are used to create a RAID array, make sure the data has been moved or backed up before creating a RAID array out of the disk drives.

- Step 1:** Select “**Create RAID 0 Striping for Performance**”. Use the arrow keys to highlight **Create RAID0 Striping for Performance** and press **ENTER**. A flashing ‘S’ appears on the **Drive Menu** where the member drives to be included in the RAID 0 array can be chosen.
- Step 2:** **Select RAID array drive members.** Use the space bar to select members of the RAID array. The flashing cursor changes to a lower case ‘s’ once any of the connected disk drives has been selected. Follow the same method to select another member drive.
- Step 3:** **Confirm.** The **Create RAID0(Y/N)** confirm box appears. Press **Y**.
- Step 4:** **Name the array.** Enter a nickname for the created array. Upper and lower case alphabetic, numeric, space, and underscore characters are all applicable for naming an array.

**NOTE:**

1. To reduce the chance of losing data, ALi imposes certain limitations on the RAID configuration options. PATA drives connected on the same IDE channel cannot be selected as the members of a RAID 0 array. Avoid mixing PATA and SATA disk drives in a RAID 0 array.
 2. Always use disk drives of the same capacity to create a RAID array. The excessive capacity of a larger disk drive cannot be utilized because data stripes are equally distributed across all members of a RAID array.
-

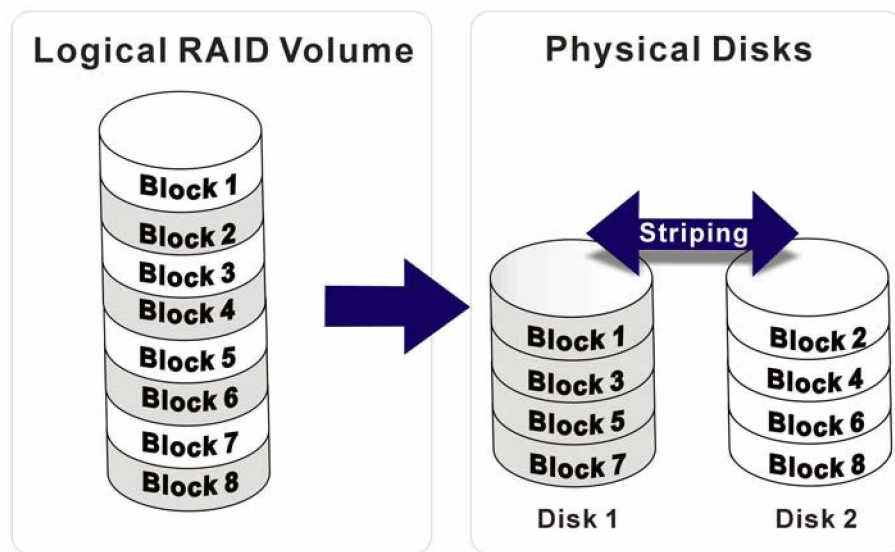

F.4.2 Create RAID 1 Mirroring for Reliability



WARNING!

All data previously stored on the member drives of a RAID configuration is **destroyed** during the RAID initialization process. If “used” drives are used to create a RAID array, make sure the data has been moved or backed up before creating a RAID array out of the disk drives.

-
- Step 1:** Select “Create RAID 1 Striping for Reliability”. Use the arrow keys to highlight **Create RAID 1 Striping for Reliability** and press **ENTER**. A flashing ‘S’ appears on the **Drive Menu** where the member drives to be included in the RAID 0 array can be chosen.
- Step 2:** **Select RAID array drive members.** Use the space bar to select members of the RAID array. The flashing cursor changes to a lower case ‘s’ once any of the connected disk drives has been selected. Follow the same method to select another member drive.
- Step 3:** **Confirm.** The **Create RAID0(Y/N)** confirm box appears. Press **Y**.

Step 4: Name the array. Enter a nickname for the created array. Upper and lower case alphabetic, numeric, space, and underscore characters are all applicable for naming an array

Step 5: View the array. A prompt appears to proceed with drive copy. The **Source** and **Destination** drives are indicated as “M” and “m” in the **Drive Menu**.



NOTE:

1. To reduce the chance of losing data, ALi imposes certain limitations on the RAID configuration options. PATA drives connected on the same IDE channel cannot be selected as the members of a RAID 1 array. Avoid mixing PATA and SATA disk drives in a RAID 1 array.
2. Always use disk drives of the same capacity to create a RAID array. The excessive capacity of a larger disk drive cannot be utilized because data stripes are equally distributed across all members of a RAID array.

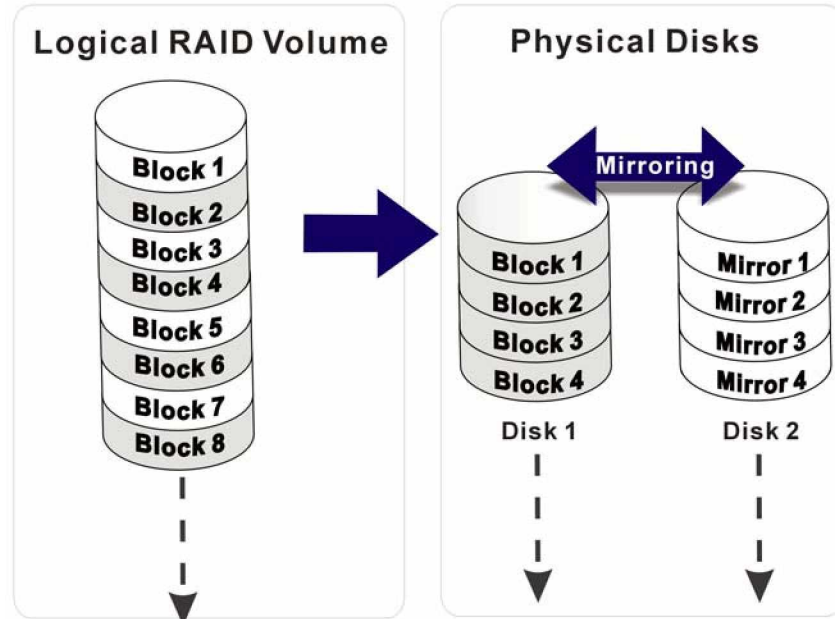

F.4.3 Create JBOD for Integrated Capacity

JBOD is defined as “Just a Bunch of Drives.” JBOD provides neither performance gains nor data redundancy.



WARNING!

All data previously stored on the member drives of a RAID configuration **is destroyed** during the RAID initialization process. If “used” drives are used to create a RAID array, make sure the data has been moved or backed up before creating a RAID array out of the disk drives.

Step 1: Select “**Create JBOD for Integrated Capacity**”. Use the arrow keys to highlight **Create JBOD for Integrated Capacity** and press **ENTER**. A flashing ‘J’ appears on the **Drive Menu** where the member drives to be included in the JBOD array can be chosen.

Step 2: Select **RAID array drive members**. Use the space bar to select members of the RAID array. The flashing cursor changes to a lower case ‘s’ once any of the connected disk drives has been selected. Follow the same method to select another member drive.

Step 3: **Confirm**. The **Create RAID 0 (Y/N)** confirm box appears. Press **Y**.

Step 4: **Name the array**. Enter a nickname for the created array. Upper and lower case alphabetic, numeric, space, and underscore characters are all applicable for naming an array



NOTE:

To reduce the chance of losing data, ALi imposes certain limitations on the RAID configuration options. Parallel-ATA drives connected on the same IDE channel cannot be selected as the members of a RAID1 array. Avoid mixing Parallel-ATA and Serial-ATA disk drives in a RAID1 array.

F.4.4 Stripe Size

Changing the stripe size effects RAID 0 arrays. Configurable options are:

- „ 64K (default)
- „ 32K
- „ 16K
- „ 8K
- „ 4K

Select a small stripe size if the I/Os to the hard drives are small and occur randomly. Choose a larger stripe size if the I/Os are mostly large and come in sequential orders, e.g., A/V playback and editing applications. The default value should be appropriate for most applications.

F.4.5 Delete RAID Setting & Partition



WARNING!

If a RAID configuration is deleted, all data previously stored on the member drives of the RAID configuration will also be deleted.

Step 1: Delete a RAID setting. Use the arrow keys to highlight **Delete RAID Setting & Partition** and press **ENTER**. A flashing 'E' appears at the **Drive Menu** where the member drives to be removed can be chosen.

Step 2: Confirm Delete. The **Data on RAID drives will be erased (Y/N)** confirm box appears. Press **Y**.

F.4.6 Delete All RAID Setting & Partition



WARNING!

If a RAID configuration is deleted, all data previously stored on the member drives of the RAID configuration will also be deleted.

3302040

Step 1: Delete RAID Settings. Use the arrow keys to highlight **Delete All RAID Setting & Partition** and press **ENTER**.

Step 2: Confirm delete. The **Data on RAID drives will be erased (Y/N)** confirm box appears. Press **Y**.

F.4.7 Rebuild RAID Array

The **Rebuild RAID Array** option can rebuild a RAID array if a member of a RAID configuration should fail. Neither RAID 0 nor JBOD provides data redundancy. The **Rebuild RAID Array** option only applies to RAID1 arrays and is applicable when a member of a RAID1 configuration has failed.

Step 1: Select Rebuild Array. Use the arrow keys to highlight **Rebuild RAID Array** and press **ENTER**. A flashing 'R' appears in the list of existing arrays. The source and destination drives will be displayed.

Step 2: Confirm rebuild array. Press **Y** to begin the rebuild process.



NOTE:

A status bar will indicate the rebuild progress. Rebuild consumes considerable system resources and the time required for rebuilding a RAID array may vary depending on the size of stored data, disk drive capacity, and drive performance.

F.4.8 Select Boot Drive

Step 1: Select the Boot Drive. Use the arrow keys to highlight **Select Boot Drive** and press **ENTER**. A flashing 'A' appears at the **Drive Menu** where the boot drive can be chosen.

Step 2: Press ENTER. Press **ENTER** or the space bar to finish the configuration.

THIS PAGE IS INTENTIONALLY LEFT BLANK

Index

A

applications 2
 AT power connector 27, 52
 AT power input connector..... 5
 ATA 33 IDE devices..... 35
 ATX power connector 28
 ATX power input connector..... 5
 audio connector..... 5, 25, 29

B

battery connector..... 5, 25

C

CompactFlash ... 5, 17, 30, 31, 32, 73, 74

D

data flow..... 13
 Digital I/O 5
 dimensions 10, 11
 DIO connector..... 32

E

Electrostatic discharge 60
 Ethernet connector 54
 Ethernet connectors..... 6
 Ethernet controller 15
 external interface connectors 54
 external peripheral interface connectors
 24

F

fan connector..... 5, 8, 25, 34

G

Graphics Processor 11, 13, 14

I

IDE controller 17
 IDE interface connectors..... 5
 inverter connector 36
 inverter power connector 5

K

keyboard and mouse connector..... 37
 keyboard/mouse connector 6

L

LED connector..... 6, 38
 low power 2
 LVDS LCD panel connector..... 6

O

onboard jumpers..... 6, 24, 27
 operating temperatures..... 18

P

parallel port connector 6, 26, 43
 PC/104 slot..... 6, 26, 45
 PCI bridge 15

power button connector.....	6, 26
power consumption	20
power switch connector	48
PS/2 Y-cable	37

R

reset button connector	6, 26, 49
RS-232	50
RS-232 serial connector	56
RS-232/422/485 serial port connector .	6, 26
RS-422	50
RS-485	50

S

SATA connectors.....	6, 7
SATA drives	16, 17, 51, 73, 76, 187
self-monitoring.....	17
Serial communications port	54
serial port devices	50

SO-DIMM socket	6, 15, 63, 64
Suspend power input connector	6, 26

T

technical specifications	7
TFT interface connector.....	6
TFT LCD LVDS	39, 41

U

UART serial ports	17
USB 2.0 ports.....	53
USB combo port	54
USB connector	6, 26, 78

V

VGA connector	6, 27, 57
VGA port.....	54

Any advice or comments about our products and service, or anything we can help you with please don't hesitate to contact with us. We will do our best to support you for your products, projects and business.

Global American Inc.

Address: 17 Hampshire Drive
Hudson, NH 03051

TEL: Toll Free (U.S. Only) 800-833-8999
(603)886-3900

FAX: (603)886-4545

Website: <http://www.globalamericaninc.com>

E-Mail: salesinfo@globalamericaninc.com

