

3304030

Half-size Single Board Computer

User's manual

Edition 1.0

2005/3/25

Copyright

© 2004 - 2005. All rights reserved. This document is copyrighted and all rights reserved.

The information in this document is subject to change without prior notice to make improvements to the products.

This document contains proprietary information and protected by copyright. No part of this document may be reproduced, copied, or translated in any form or any means without prior written permission of the manufacturer.

All trademarks and/or registered trademarks contains in this document are property of their respective owners.

Disclaimer

The company shall not be liable for any incidental or consequential damages resulting from the performance or use of this product.

The company does not issue a warranty of any kind, express or implied, including without limitation implied warranties of merchantability or fitness for a particular purpose.

The company has the right to revise the manual or include changes in the specifications of the product described within it at any time without notice and without obligation to notify any person of such revision or changes.

Trademark

All trademarks are the property of their respective holders.

Hardware:

3304030 Single Board Computer x 1

Cable Kit:



40-pin ATA100 IDE flat cable x 1



Floppy flat cable x 1

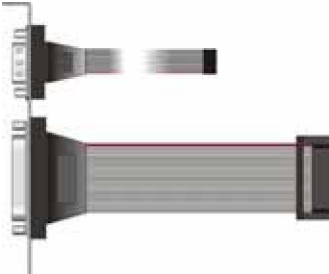

DB25 & DB9 cable with bracket x 1

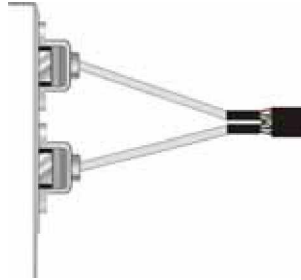

Dual USB cable with bracket x 1

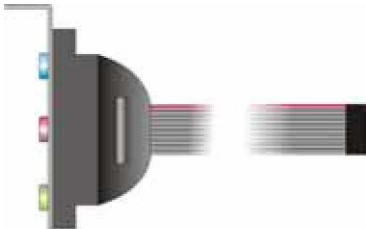

Audio cable with bracket x 1

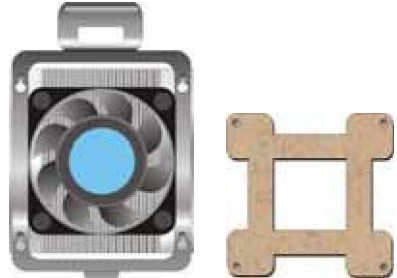

CPU Cooler x 1

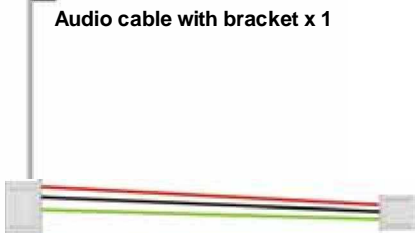

4-pin to 3-pin ATX cable x 1



PS/2 Keyboard & Mouse Cable x 1

Other Accessories:

Divers CD (including User's Manual)

Index

Chapter1 <Introductions>	7
1.1 <Product Overview>	7
1.2 <Product Specification>	8
1.3 <Component Placement>.....	10
1.4 <Block Diagram>	11
Chapter 2 <Hardware Setup>	13
2.1 <Connectors Location>	13
2.2 <Jumper Reference>	14
2.3 <Connectors Reference>	15
2.3.1 <Internal Connectors>.....	15
2.3.2 <External Connector>	15
2.4 <System Setup>.....	16
2.4.1 <CPU setup>.....	16
2.4.2 <Memory Module setup>.....	17
2.4.3 <CPU cooler setup>.....	18
2.4.4 <Complete the system installation>	19
2.5 <CMOS Setup>.....	20
2.6 <Watchdog Timer Setting>	21
2.7 <Embedded Solid State Disk>	22
2.8 <Power and Fan Setup>	23
2.9 <Display Interface>.....	24
2.9.1 <Analog VGA interface>	24
2.9.2 <Digital VGA interface>	25
2.10 < Ethernet Network Interface>	29
2.11 <Audio Interface>.....	30
2.12 <GPIO interface>.....	31
2.13 <Switch and Indicator>.....	32
Chapter 3 <Display Mode Setup>	33

Chapter 4 <BIOS Setup>	37
Appendix A <I/O ports pin assignment>	39
A.1 <IDE Port>.....	39
A.2 <Floppy Port>	41
A.3 < Parallel Port>	42
A.4 <Serial Port>.....	43
A.4.1 <External DB9 COM>	43
A.4.2 <Internal COM2>.....	43
A.5 <USB Port>	44
A.6 <IrDA Port>.....	44
A.7 <VGA Port>	45
A.8 <LAN Port>.....	45
A.9 <AT Keyboard Port>	46
A.10 <PS/2 Keyboard & Mouse Port>.....	46
Appendix B <Flash BIOS>	47
B.1 BIOS Auto Flash Tool	47
B.2 Flash Method	47
Appendix C <Watchdog Timer Programming Guide>	49
Appendix D <Hardware Test>	53
D.1 <Power Consumption>	53
Contact Information	54

(This Page is Left for Blank)

(This Page is Left for Blank)

Chapter1 <Introductions>

1.1 <Product Overview>

The **3304030** is an all-in-one single board computer with PISA bus. Based on Intel Mobile solutions with 852GM chipset, it is bundled with Intel Mobile Celeron 1.2GHz processor, DDR266 SDRAM up to 1GB of capacity, Intel Extreme Graphics Technology of onboard VGA display interface, AC97 2-channel audio, USB2.0 interface and one Gigabit Ethernet controller.

To be a powerful multimedia platform, **3304030** is also integrated with 24-bit dual channel LVDS interface and one Compact Flash Type II socket. For these features **3304030** can be easily used for industrial multimedia platform like POS or KIOSK system.

Intel 852GM & ICH4 chipset

Based on Intel 852GM and ICH4 chipset, the board supports Intel Pentium 4 –M and Mobile Celeron M with 400MHz of front-side-bus, DDR200/266 memory, 24-bit dual-channel LVDS interface, Intel Extreme Graphic Technology of onboard VGA.

Dual Display Interface

The board supports dual display interface with CRT monitor and LCD panel, for extended desktop or clone mode supported. Users can have the different resolution or color bit for each display device.

Hi-Speed USB 2.0 Interface

Intel ICH4 built-in Hi-Speed USB 2.0 controller let **3304030** offering up to 480Mbps of Hi-Speed USB 2.0 interfaces.

1.2 <Product Specification>

General Specification

Form Factor	Half-size PISA CPU card
CPU	Intel Pentium 4 –M / Mobile Celeron Processor Supports up to 1.2GHz Battery Mode is not supported Intel Speed Step Technology is not supported
Memory	1GBytes DDR200/266 SDRAM on one 184-pin DIMM socket Non-ECC, un-buffered Memory is supported
Chipset	Intel 82852GM GMCH and 82801DB ICH4
BIOS	Phoenix-Award v6.00PG 4Mb PnP flash BIOS
Green Function	Power saving mode includes doze, standby and suspend modes. ACPI version 1.0 and APM version 1.2 compliant
Watchdog Timer	System reset programmable watchdog timer with 1 ~ 255 sec./min. of timeout value
Real Time Clock	Intel ICH4 built-in RTC with lithium battery
Enhanced IDE	PCI enhanced IDE interface supports dual channels and up to 4 ATAPI devices at UltraATA/100 One 40-pin and one 44-pin IDE port DiskOnModule (DOM) embedded flash disk up to 1GBytes

Multi-I/O Port

Chipset	Intel 82801DB ICH4 and Winbond W83627HF-AW LPC Super I/O controller
Serial Port	One external and one internal RS-232 serial ports with 16C550 compatible UART and 16 bytes FIFO
USB Port	Two Hi-Speed USB 2.0 ports with 480 Mbps of transfer rate
Parallel Port	One internal bi-direction parallel port with SPP/ECP/EPP mode
Floppy Port	One FDD port supports up to two FDD
IrDA Port	One IrDA compliant Infrared interface supports SIR
K/B & Mouse	External PS/2 keyboard and mouse ports on rear I/O panel One internal AT keyboard port
GPIO	One 12-pin Digital I/O connector with 8-bit programmable I/O interface

VGA Display Interface

Chipset	Intel 852GM GMCH built-in Intel Extreme Graphics Technology
Memory	Intel dynamic video memory up to 64Mbytes shared with system
Display Type	CRT, LCD monitor and analog display
Connector	External DB15 female connector on rear I/O panel Internal 40-pin LVDS connector

Ethernet Interface

Chipset	Intel PRO/1000+ LAN interface with Intel 82540EM
Type	10Base-T / 100Base-TX/1000Base-T, auto-switching Fast Ethernet Full duplex, IEEE802.3U compliant
Connector	External RJ45 connector with LED on rear I/O panel

Audio Interface

Chipset	Intel ICH4 with Realtek ALC201A AC97 3D audio codec
Interface	2 channel 3D audio with Line-in, Line-out and MIC-in
Connector	Internal 10-pin header for line-in/-out, MIC-out, 4-pin header for CD-in

Solid State Disk Interface

Flash Type	Compact Flash Type-I/II for CFC (Compact Flash Card) or IBM MicroDrive
Capacity	Up to 1 GB flash memory

Power and Environment

Power Requirement	4-pin onboard +5V/+12V power connector
ATX function	Onboard 3-pin PS-ON & 5V standby connector
Dimension	185 (L) x 127 (H) mm
	Storage within -20 ~ 85 °C (°F)
	F)

Ordering Code

3304030	Half-size PISA bus single board computer with Intel Mobile Celeron processor 1.2GHz , onboard VGA, Gigabit LAN, Audio, Hi-Speed USB 2.0, Compact Flash socket and LVDS interface.
----------------	--

1.3 <Component Placement>

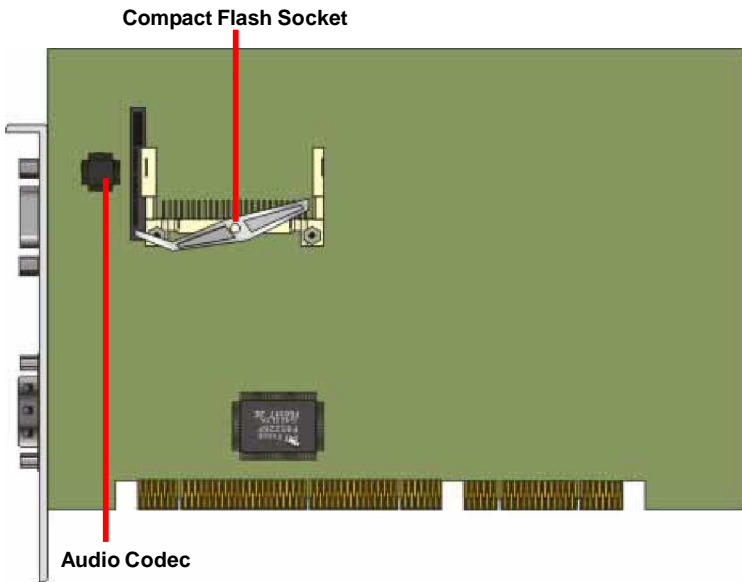
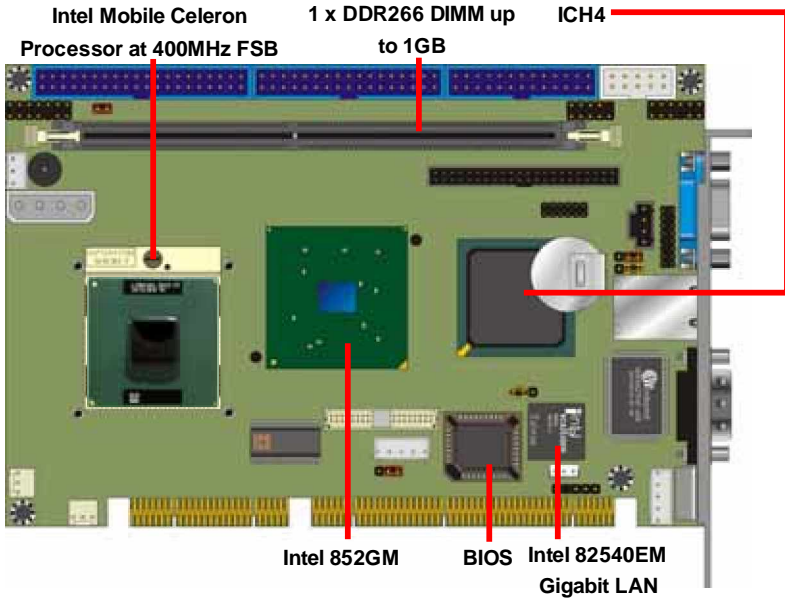

1.4 <Block Diagram>

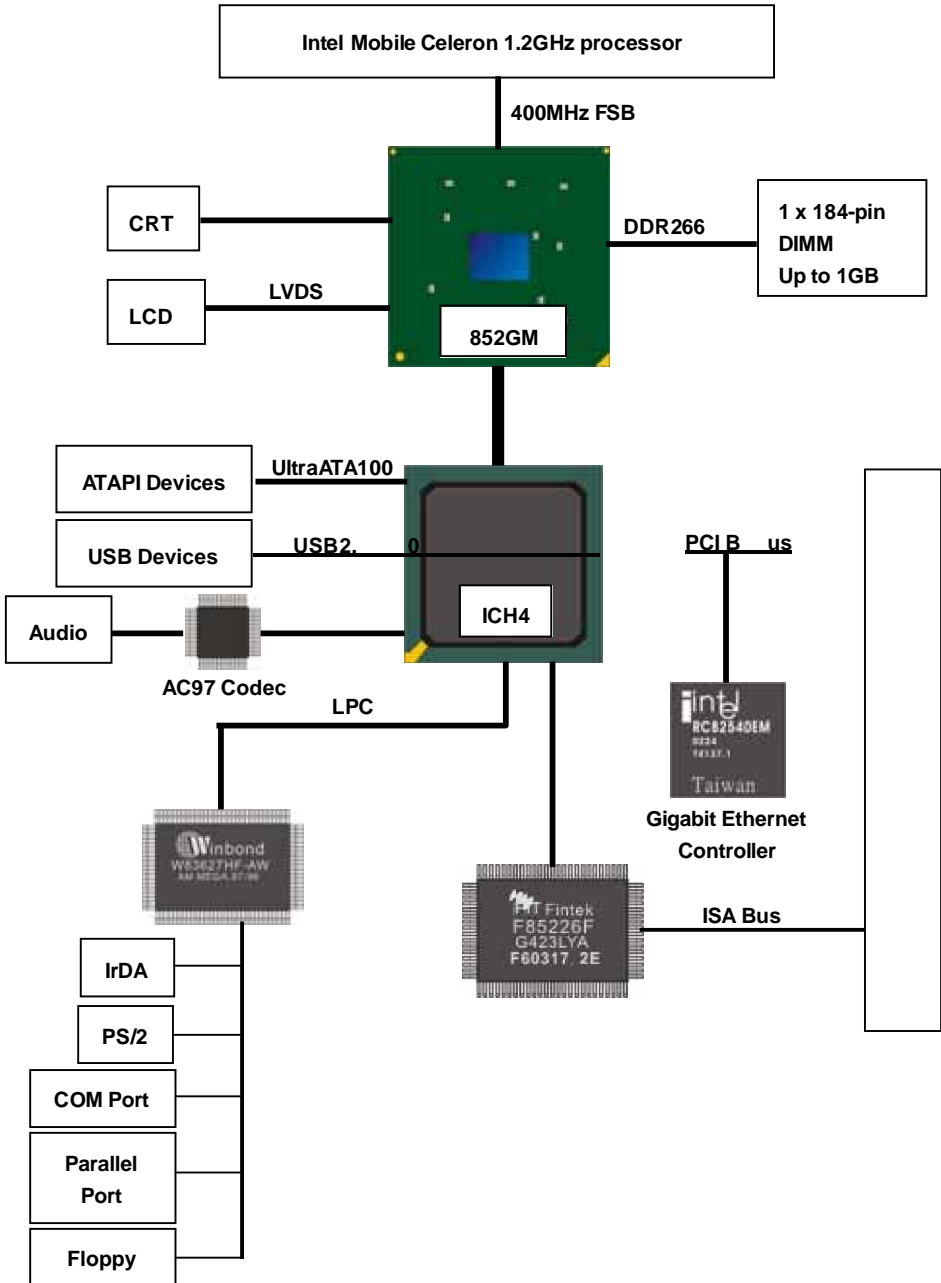

(This Page is Left for Blank)

(This Page is Left for Blank)

Chapter 2 <Hardware Setup>

2.1 <Connectors Location>

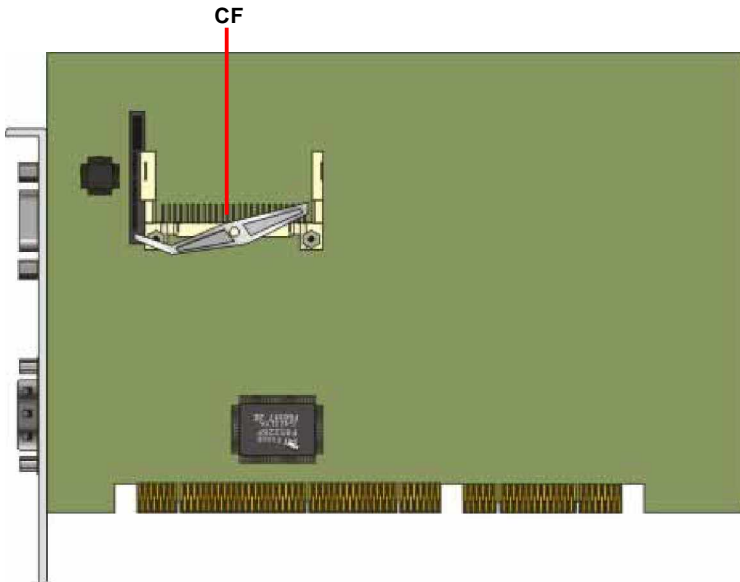
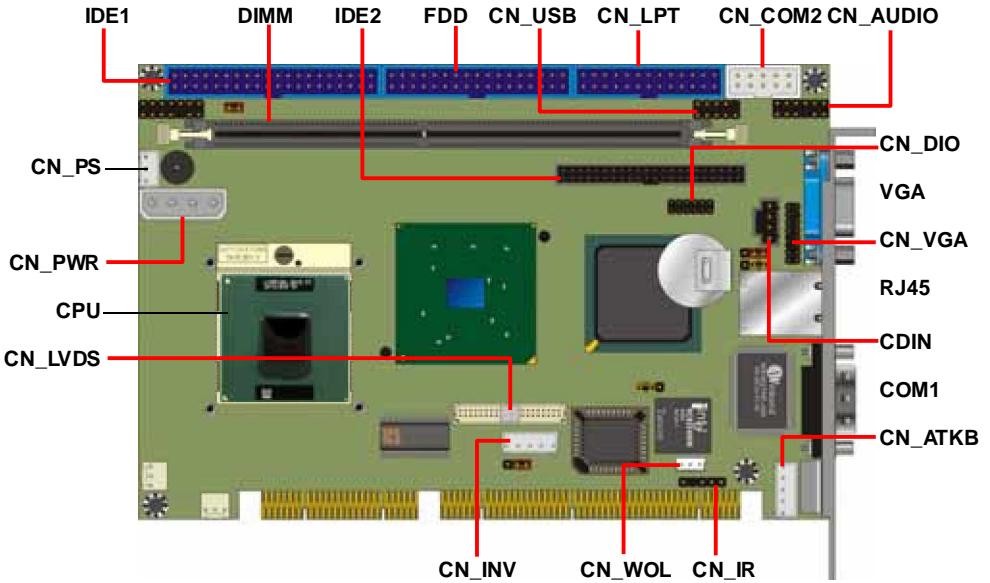

2.2 <Jumper Reference>

Jumper	Function
JRTC	CMOS Operating/Clear Setting
JCFSEL	Compact Flash Addressing Setting
JDOM	IDE1 Pin-20 voltage setting
JVLCD	LCD Panel Voltage Setting
JLAN	Ethernet Controller Enable/Disable Setting

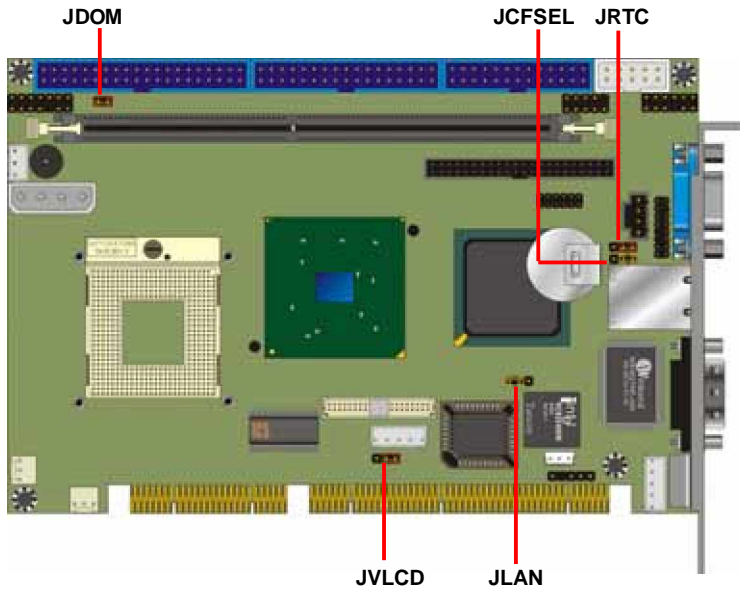

2.3 <Connectors Reference>

2.3.1 <Internal Connectors>

Connector	Function	Remark
CPU	mPGA479 CPU socket	Standard
DIMM	184 -pin DDR SDRAM DIMM socket	Standard
IDE1	40-pin primary IDE connector	Standard
IDE2	44-pin secondary IDE connector	Standard
FDD	34-pin floppy connector	Standard
CN_VGA	8 x 2-pin VGA connector (pitch = 2.0mm)	Standard
CN_USB	5 x 2-pin USB connector (pitch =2.54mm)	Standard
CN_COM2	5 x 2-pin serial port connector	Standard
CN_LVDS	20 x 2-pin LVDS connector	Standard
CN_INV	5-pin panel inverter connector	Standard
CN_PS	3-pin ATX function connector	Standard
CN_PWR	4-pin power input connector	Standard
CN_AUDIO	5 x 2-pin audio connector	Standard
CDIN	4-pin CD-ROM audio input connector	Standard
CN_DIO	6 x 2-pin digital I/O connector	Standard
CN_WOL	3-pin wake-on-LAN connector	Standard
CPUFAN	3-pin CPU fan connector	Standard
SYSFAN	3-pin system fan connector	Standard
CN_LPT	26-pin parallel port connector	Standard
CF	Compact Flash Type II socket	Standard

2.3.2 <External Connector>

Connector	Function	Remark
VGA	DB15 VGA connector	Standard
RJ45	RJ45 LAN connector	Standard
COM1	Serial port connector	Standard
PS2	PS/2 Keyboard/Mouse connector	Standard

2.4 <System Setup>

2.4.1 <CPU setup>

3304030 has one 479-pin CPU socket to support Intel Pentium 4 –M / Mobile Celeron processor up to 1.2GHz. Please follow the instruction to install the processor well.

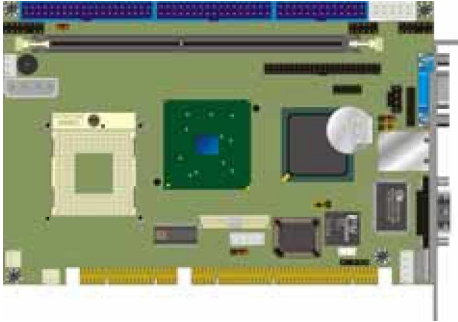

CPU Socket

1. Use flat-type Screw Driver to unlock the CPU locket

CPU locket

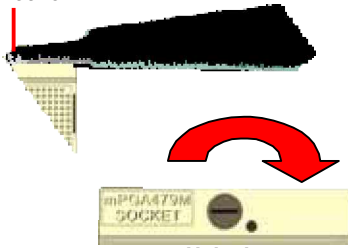

Unlock way

2. Find the pin direction and install the processor on the socket.

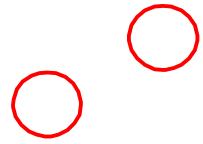

3. Lock the socket well.

2.4.2 <Memory Module setup>

3304030 supports one DDR266 SDRAM up to 1GB of capacity, with non-ECC, un-buffered memory supported.

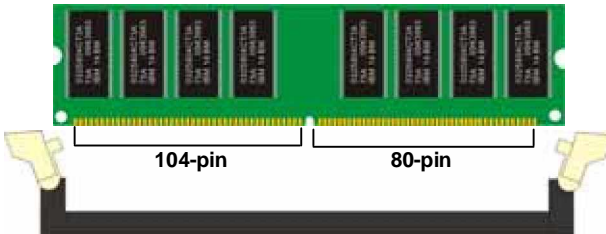
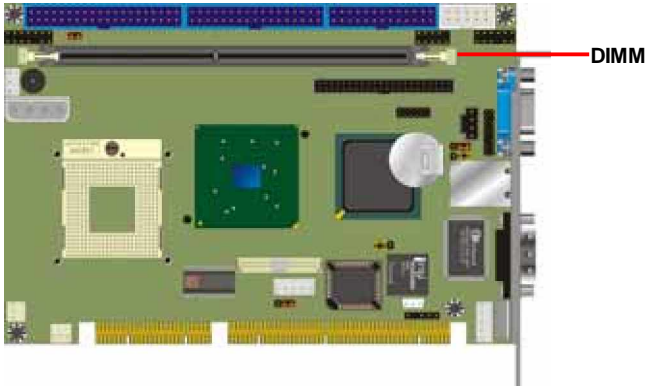

Please check the pin number to match the socket side well before installing memory module.

2.4.3 <CPU cooler setup>

There is a cooler attached with the board package, please follow the instructions to install the cooler on the processor.

1. Remove the sticker of the base.

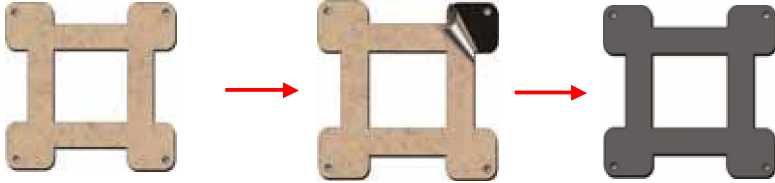

2. Put the base through the fixing hole of the processor and paste on the solder side. Then put the cooler through the base pillar.

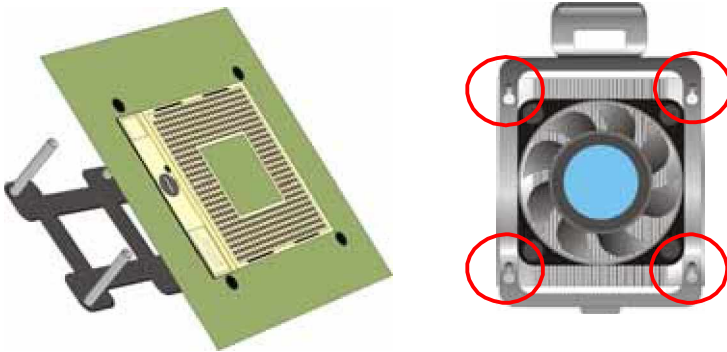

3. Press the both sides of the cooler shield down and push it to move front

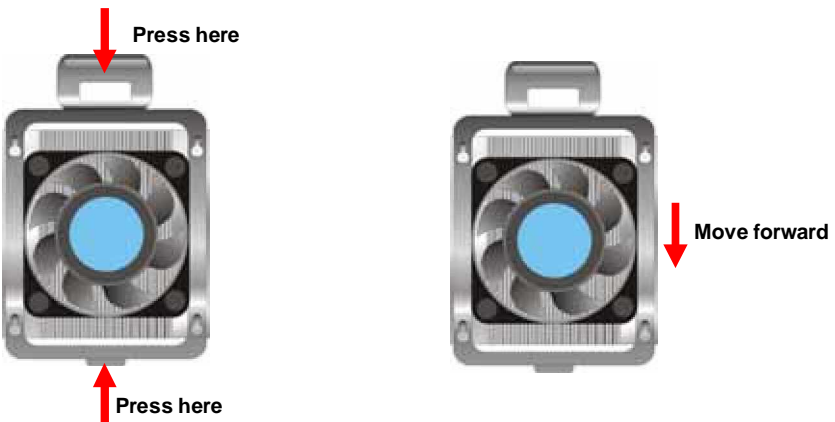

2.4.4 <Complete the system installation>

After installing the CPU, CPU cooler and the memory module, please slot the main board into PISA slot of the backplane carefully. If you connect an ATX power supply with the backplane, you will need to connect an ATX function cable between the main board and the backplane.

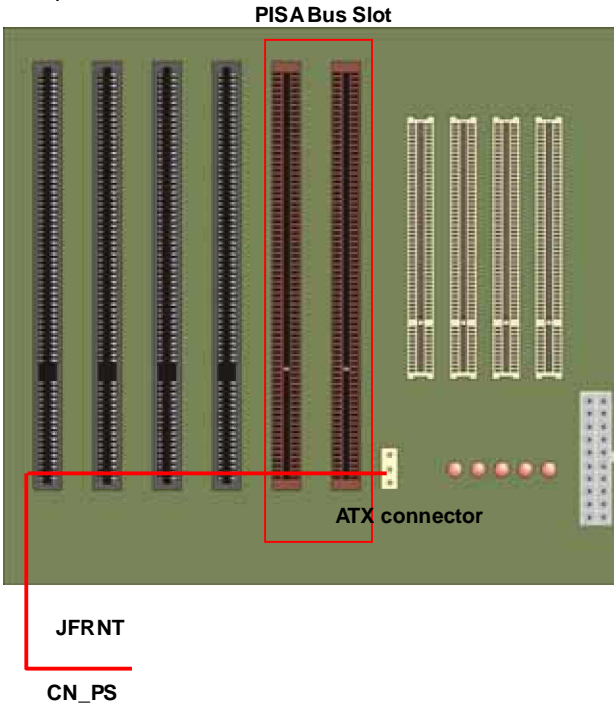

Notice:
The ATX function connector may have different types on different backplanes, please check the pin assignment for the connector on the backplane before you install the ATX function cable.

To power supply

To power on the system, please check chapter 10 to short the power button pin on JFRNT.

2.5 <CMOS Setup>

The board's data of CMOS can be setting in BIOS. If the board refuses to boot due to inappropriate CMOS settings, here is how to proceed to clear (reset) the CMOS to its default values.

Jumper: JRTC

Type: Onboard 3-pin jumper

JRTC	Mode
1-2	Clear CMOS
2-3	Normal Operation

Default setting

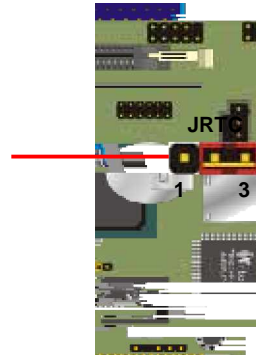

2.6 <Watchdog Timer Setting>

The watchdog timer makes the system auto-reset while it stops to work for a period. The integrated watchdog timer can be setup as system reset mode by program.

Timeout Value Range

- 1 to 255
- Second or Minute

Program Sample

Watchdog timer setup as system reset with 5 second of timeout

```

2E, 87
2E, 87
2E, 07
2F, 08      Logical Device 8
2E, 30      Activate
2F, 01
2E, F5      Set as Second*
2F, 00
2E, F6      Set as 5
2F, 05

```

* Minute: bit 3 = 0; Second: bit 3 = 1

You can select Timer setting in the BIOS, after setting the time options, the system will reset according to the period of your selection.

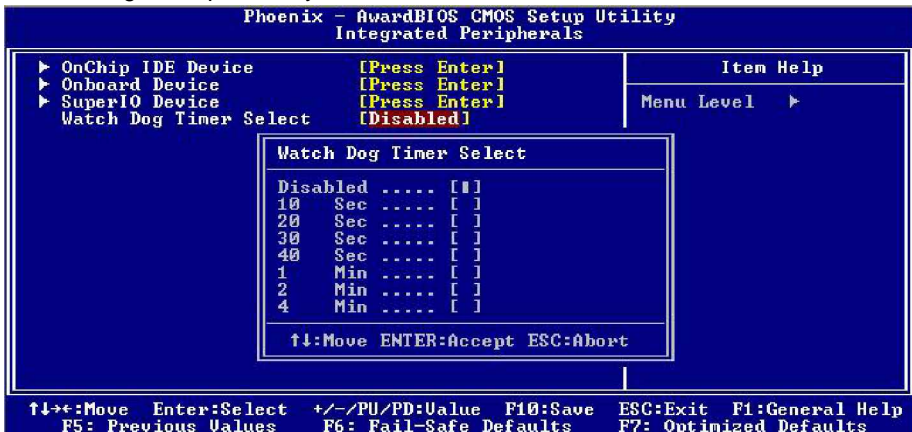

For more specification of watchdog timer program, please check appendix document.

2.7 <Embedded Solid State Disk>

The **3304030** supports the IDE-based, bootable and driver free DiskOnModule (DOM) embedded flash disk. The onboard 40-pin IDE1 and 44-pin IDE2 box header supports normal DOM (DiskOnModule) or M-systems DiskOnChip IDE Pro flash disk with or without the additional VCC power cable.

The **3304030** also supports Compact Flash Card Type I/II interface. The jumper **JCFSEL** provides you to setup the CF card on master or slave mode.

Jumper: **JCFSEL**

Type: onboard 3-pin header

JCFSEL	Mode
1-2	Master
2-3	Slave

Default setting

Jumper: **JDOM**

Type: onboard 3-pin header

JDOM	Mode
ON	IDE1 pin-20 5V power supply enable
OFF	No 5V power supply on IDE1 pin-20

Default setting

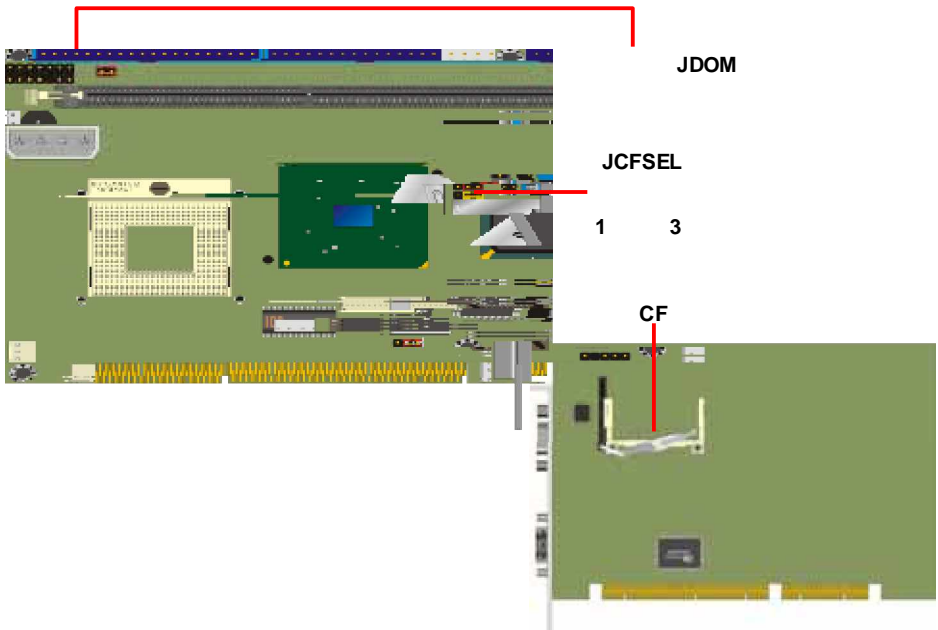

2.8 <Power and Fan Setup>

3304030 has one 4-pin power input connector expect PISA bus powering; it also has two fan connectors. For ATX function, you should connect the ATX connector on the backplane with CN_PS on 3304030.

Connector: **CN_PWR**

Type: 4-pin P-type connector for +5V/+12V input

Pin	Description	Pin	Description	Pin	Description	Pin	Description
1	+12V	2	Ground	3	Ground	4	+5V

Connector: **CPUFAN, SYSFAN**

Type: 3-pin fan wafer connector

Pin	Description	Pin	Description	Pin	Description
1	Ground	2	+12V	3	Fan Control

Connector: **CN_PS**

Type: 3-pin ATX function connector

Pin	Description	Pin	Description	Pin	Description
1	5V Standby	2	Ground	3	Power On

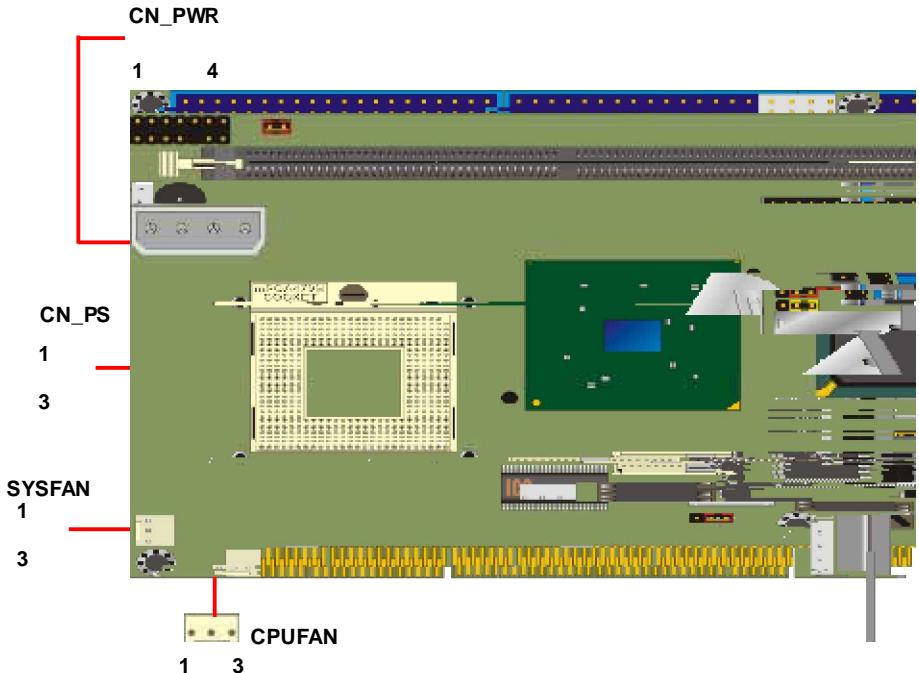

2.9 <Display Interface>

2.9.1 <Analog VGA interface>

The board is integrated with Intel 852G GMCH chipset built-in Intel Extreme Graphics Technology with Intel Dynamic Video Memory up to 64MBytes shared with system memory. The CRT / analog VGA interface includes one external DB15 female connector on bracket and one 8 x 2-pin header connector on board.

(The two interfaces can not be used at the same time)

Connector: **CN_VGA**

Type: 16-pin (2 x 8) pin header (pitch = 2.0mm)

Pin	Description	Pin	Description
1	Red	9	Green
2	Blue	10	N/C
3	Ground	11	Ground
4	Ground	12	Ground
5	N/C	13	Ground
6	N/C	14	Data
7	HSYNC	15	VSYNC
8	Clock	16	N/C

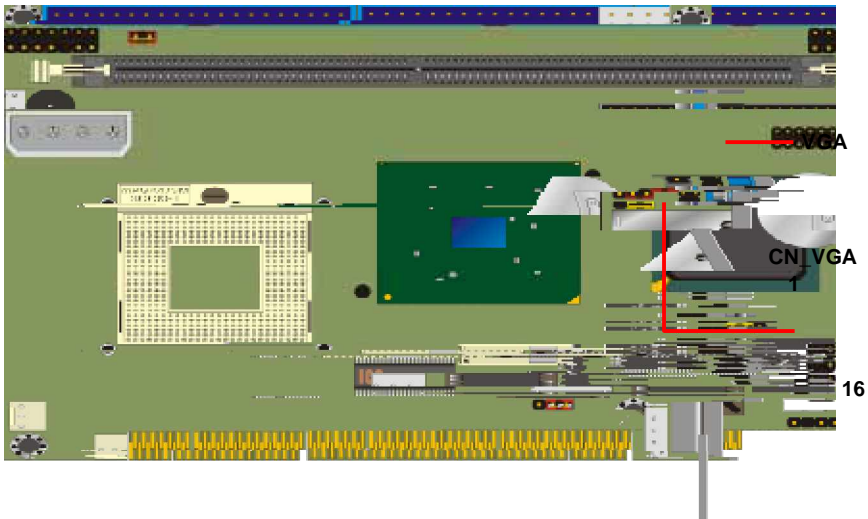

2.9.2 <Digital VGA interface>

The board provides one 20 x 2-pin LVDS interface for LCD panel, it supports 18/24-bit single/dual channel up to 1600 x 1200 of resolution. The jumper **JVLCD** can let you select your panel whether supports +5V or +3.3V of voltage, and the **CN_INV** provides panel inverter interface includes backlight controlling and powering.

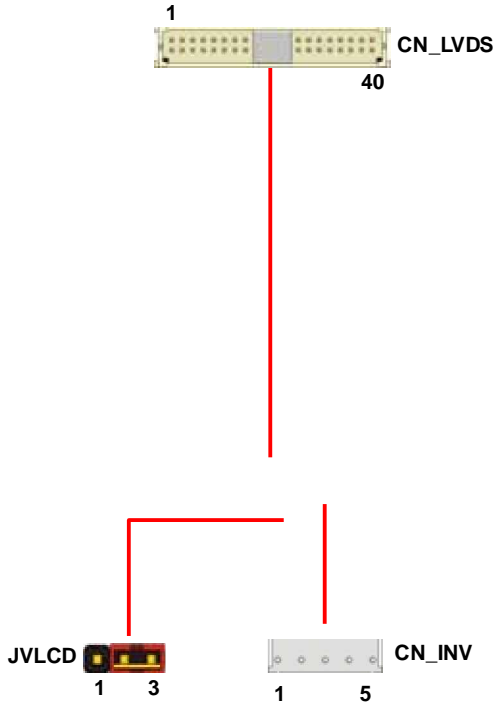

Connector: **CN_INV**

Type: 5-pin LVDS Power Header

Pin	Description
1	+12V
2	GND
3	GND
4	GND
5	ENABKL

Connector: **JVLCD**

Type: 3-pin Power select Header

Pin	Description
1	VCC
2	LCDVCC
3	VCC3

Connector: **CN_LVDS**

Type: onboard 40-pin connector for LVDS connector

Connector model: **HIROSE DF13-40S**

Pin	Signal	Pin	Signal
2	LCDVCC	1	LCDVCC
4	GND	3	GND
6	ATX0-	5	BTX0-
8	ATX0+	7	BTX0+
10	GND	9	GND
12	ATX1-	11	BTX1-
14	ATX1+	13	BTX1+
16	GND	15	GND
18	ATX2-	17	BTX2-
20	ATX2+	19	BTX2+
22	GND	21	GND
24	ATXCK-	23	BTX3-
26	ATXCK+	25	BTX3+
28	GND	27	GND
30	ATX3-	29	BTXCK-
32	ATX3+	31	BTXCK+
34	GND	33	GND
36	PANELCLK	35	N/C
38	PANELDATA	37	N/C
40	N/C	39	N/C

To setup the LCD, you need the components below:

1. A panel (support up to 24-bit dual channel) with LVDS interfaces.
2. An inverter for panel's backlight power.
3. A LCD cable and an inverter cable.

For the cables, please follow the pin assignment of the connector to make a cable, because every panel has its own pin assignment, so we do not provide a standard cable; please find a local cable manufacture to make cables.

LCD installing guide:

1. Prepare a panel, inverter and **3304030**.



870P SBC



LCD panel

Inverter

2. Please check the datasheet of the panel to see the voltage of the panel, and set the jumper **JVLCD** to +5V or +3.3V.
3. Prepare a LVDS type LCD cable

Panel side

For sample illustrator only

Board side

4. Connect all the devices well.

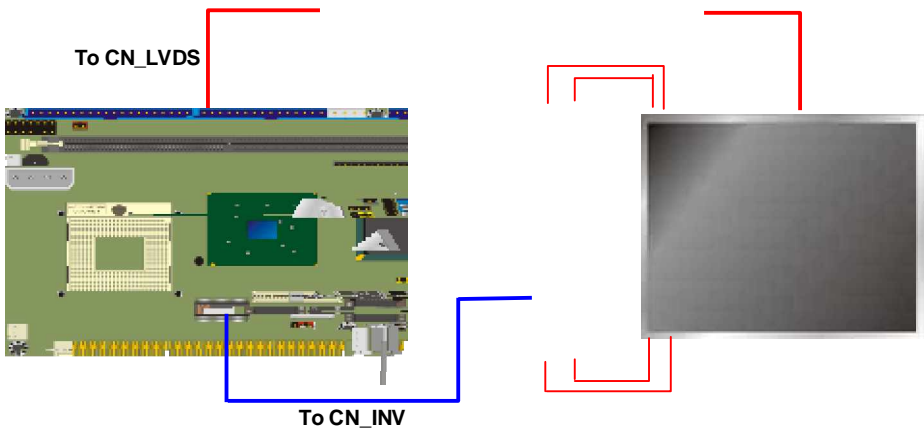

After setup the devices well, you need to select the LCD panel type in the BIOS.

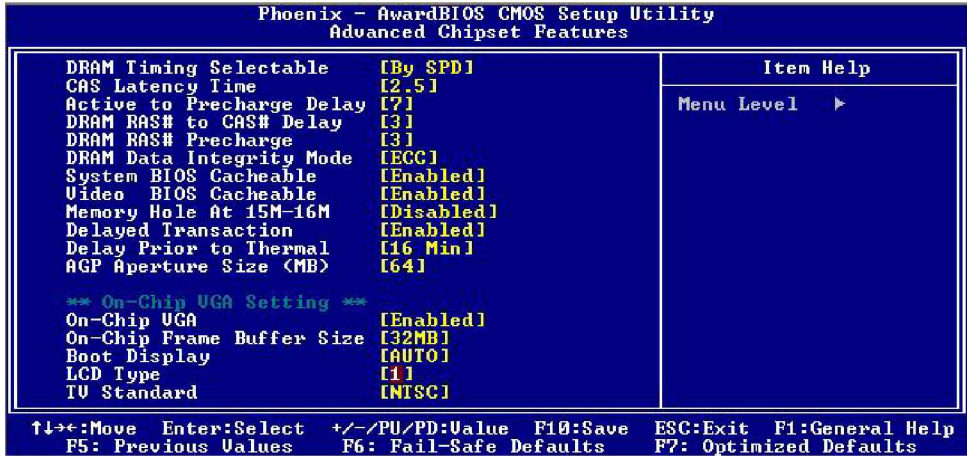

The panel type mapping is list below:

BIOS panel type selection form			
For 18-bit color		For 24-bit color	
NO.	Output format	NO.	Output format
1	640 x 480	8	1024 x 768
2	800 x 600	9	1280 x 1024 Dual Channel
3	1024 x 768	10	1400 x 1050 Dual Channel
4	1280 x 1024	11	1600 x 1200 Dual Channel
5	1400 x 1050 Dual Channel @ 108Mhz	13	1024 x 768 Dual Channel
6	1400 x 1050 Dual Channel @ 122Mhz	14	1920 x 1080 Dual Channel
7	1600 x 1200 Dual Channel		
12	1024 x 768 Dual Channel		

2.10 < Ethernet Network Interface >

The **3304030** is integrated with Intel PRO/1000+ Gigabit Ethernet interface at the type of 10Base-T/100Base-TX/100Base-T auto-switching Ethernet with full duplex and IEEE 802.3U compliant. The **3304030** Ethernet interface is controlled by Intel 82540EM, and it provides the external RJ45 connector on rear I/O panel. The jumper **JLAN** can let you set to enable/disable onboard network function.

Connector: **CN_WOL**

Type: onboard 3-pin (1 x 3) wafer connector

Pin	1	2	3
Description	WOL-Ctrl	Ground	+5V Standby

Jumper: **JLAN**

Type: onboard 3-pin header

JRTC	Mode
1-2	Enable Onboard LAN controller
2-3	Disable Onboard LAN controller

Default setting

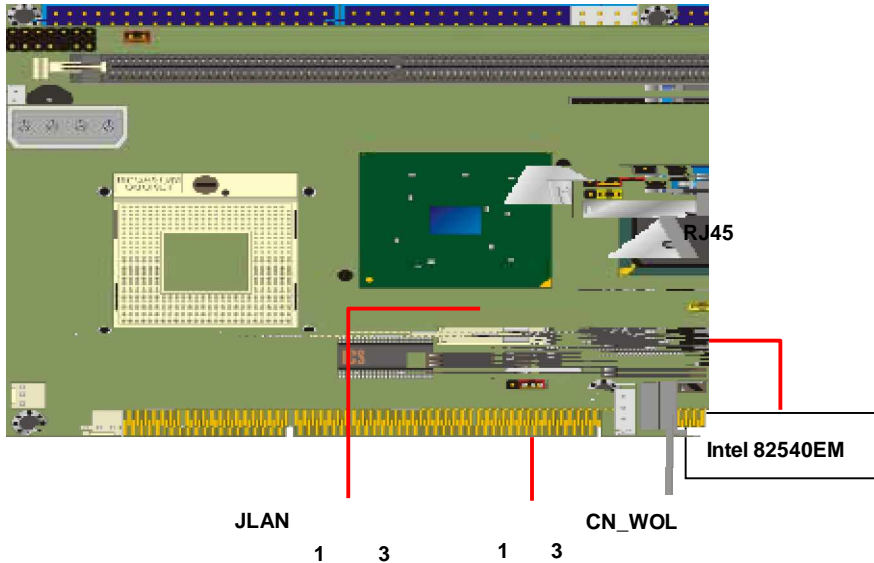

2.11 <Audio Interface>

3304030 provides a stereo audio interface with Realtek ALC201A AC97 Codec. The **CN_AUDIO** provides the interface to use attached audio cable, the **CDIN** can let you connect audio output from CD-ROM drives.

Connector: CN_AUDIO

Type: 10-pin (2 x 5) 2.54-pitch header

Pin	Description	Pin	Description
1	Line – Right	2	Ground
3	Line – Left	4	MIC
5	MIC	6	Ground
7	N/C	8	Line Out – Left
9	Line Out – Right	10	Ground

Connector: CDIN

Type: 4-pin header

Pin	Description
1	CD – Left
2	Ground
3	Ground
4	CD – Right

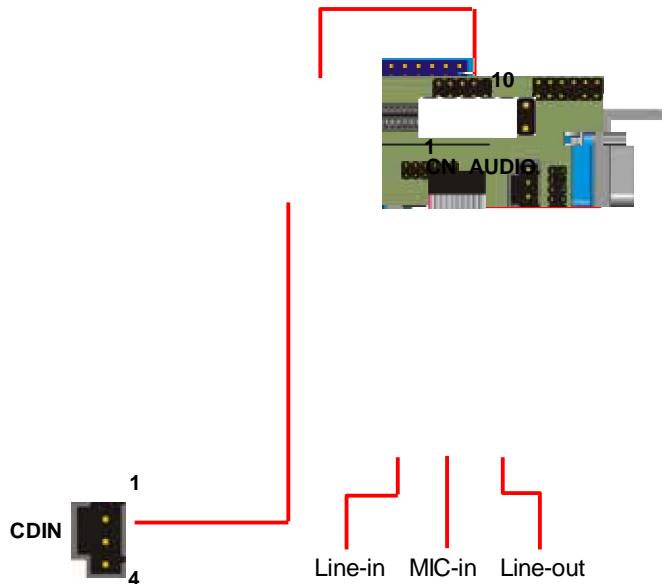

2.12 <GPIO interface>

The board offers 8-bit digital I/O to customize its configuration to your control needs. For example, you may configure the digital I/O to control the opening and closing of the cash drawer or to sense the warning signal from a tripped UPS. The following is a detailed description of how the digital I/O is controlled via software programming.

Connector: **CN_DIO**

Type: 12-pin (6 x 2) header (pitch = 2.0mm)

Pin	Description	Pin	Description
1	Ground	2	Ground
3	LGP0	4	LGP4
5	LGP1	6	LGP5
7	LGP2	8	LGP6
9	LGP3	10	LGP7
11	VCC	12	+12V

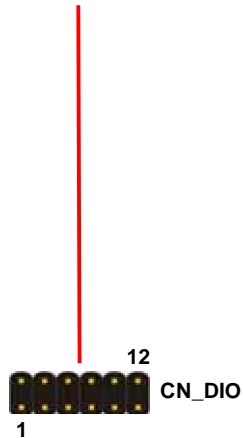

2.13 <Switch and Indicator>

The **JFRNT** provides front control panel of the board, such as power button, reset and beeper, etc.

Connector: **JFRNT**

Type: onboard 14-pin (2 x 7) 2.54-pitch header

Function	Signal	PIN		Signal	Function
IDE LED	VCC (+)	1	2	(+) VCC	Power LED
	Active	3	4	N/C	
Reset	Reset	5	6	GND	Speaker
	GND	7	8	VCC	
N/C		9	10	N/C	
Power Button	PWRBT	11	12	N/C	
	5VSB	13	14	SPKIN	

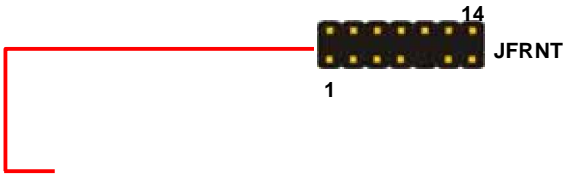

Chapter 3 <Display Mode Setup>

This chapter shows you how to setup the display device under Windows OS.

Before you using your display device:

1. Check your software

Before you can use the display device properly, please install the VGA driver.

2. Check your hardware

Please setup the display device properly before you boot up the system.

For configure your Display device, please follow the instructions below:

1. Please lunch Display Properties.

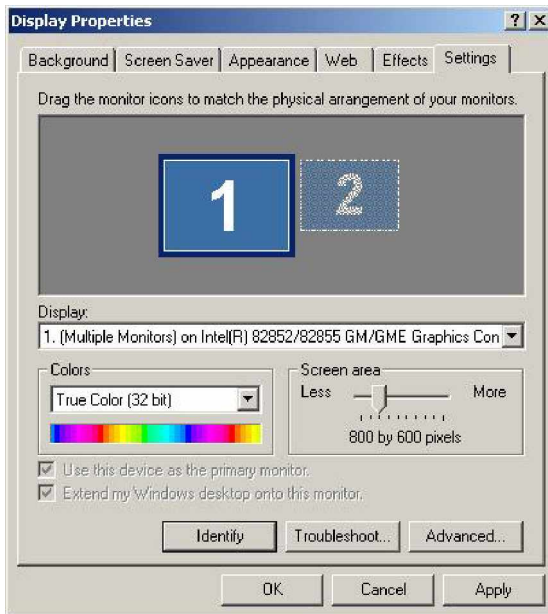

You would see two Graphics Controllers. If you connect two display devices, you would be able to setup each device for color bit and resolution.



This item can let you configure which device would be the primary if you connect two display devices.



This item can let you extend your Windows Desktop to second display device.

If you click the identify button, the screen will pop up the number sequence of your device.

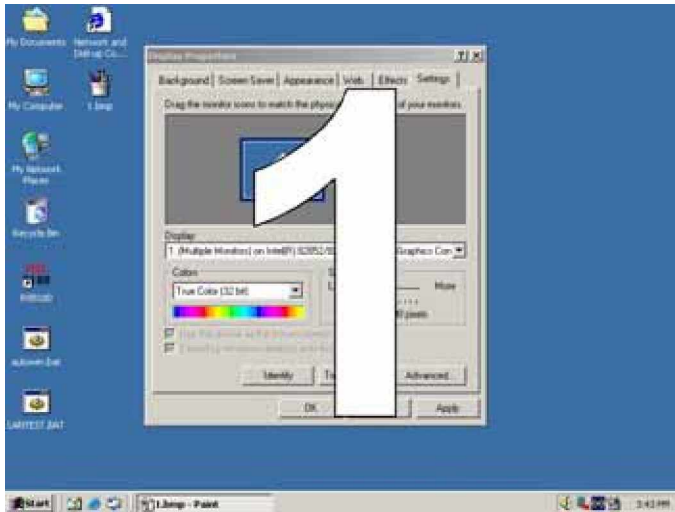

For advanced display settings, please click Advanced... button and choose Intel(R) Extreme Graphics.

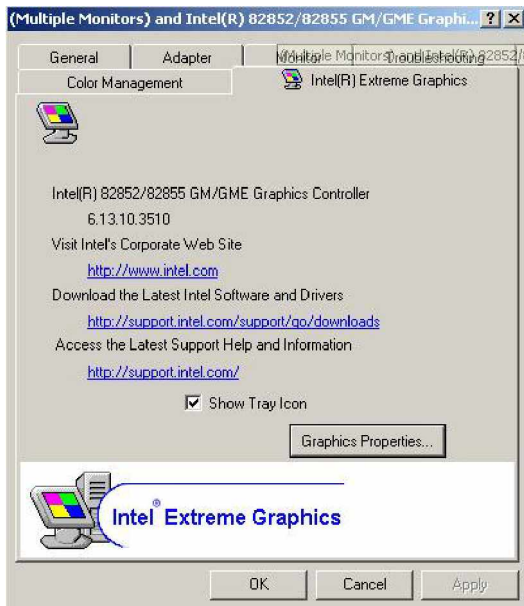

Please click Graphics Properties button to enter the advanced setup.

While you entering the Graphics Properties, you will see the options below:

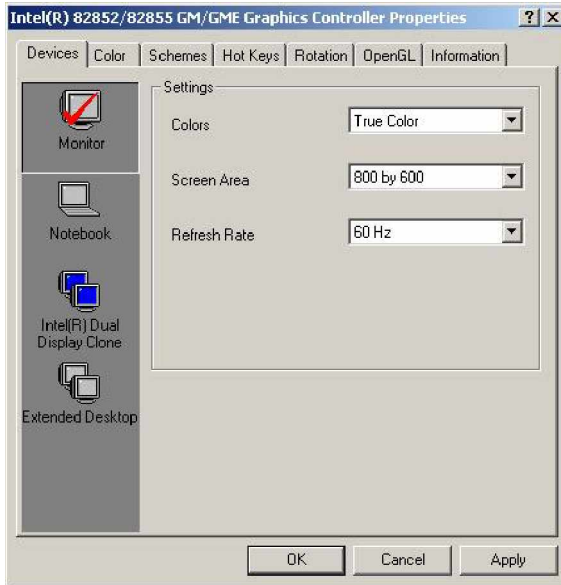

This option can let you configure the CRT monitors for Colors, Screen Area (Resolution) and Refresh Rate.

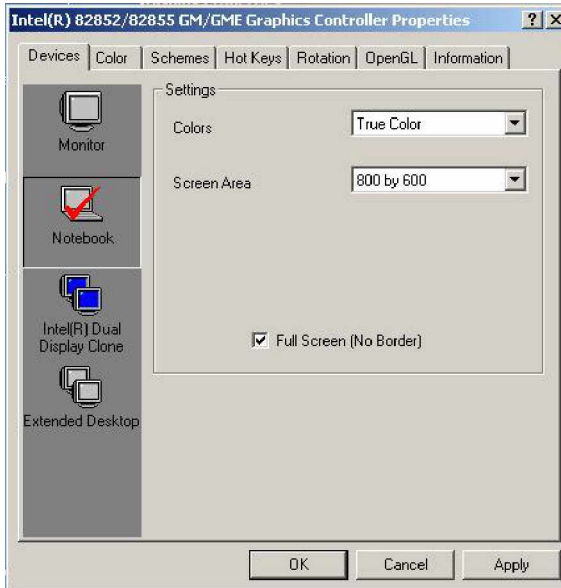

This option can let you configure the LCD panel for Colors, Screen Area (Resolution) and Full Screen option.

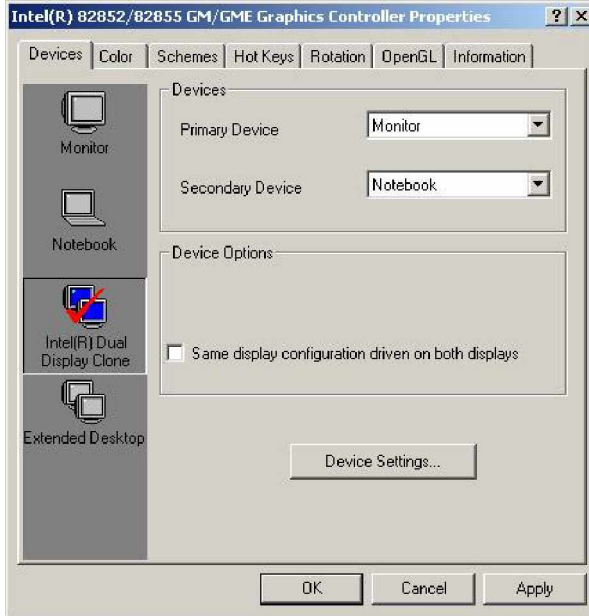

This option can let you configure the Dual Display for clone mode (same display on two devices)

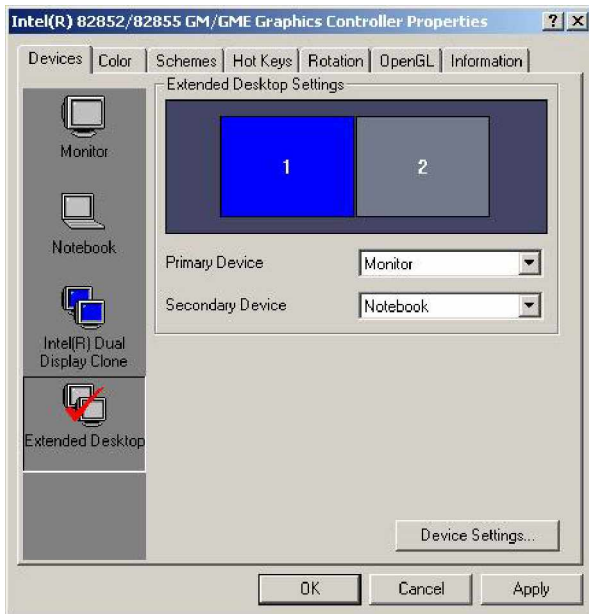

This option can let you configure the Dual Display for Extended Desktop mode

Chapter 4 <BIOS Setup>

The single board computer uses the Award BIOS for the system configuration. The Award BIOS in the single board computer is a customized version of the industrial standard BIOS for IBM PC AT-compatible computers. It supports Intel x86 and compatible CPU architecture based processors and computers. The BIOS provides critical low-level support for the system central processing, memory and I/O sub-systems.

The BIOS setup program of the single board computer let the customers modify the basic configuration setting. The settings are stored in a dedicated battery-backed memory, NVRAM, retains the information when the power is turned off. If the battery runs out of the power, then the settings of BIOS will come back to the default setting.

The BIOS section of the manual is subject to change without notice and is provided here for reference purpose only. The settings and configurations of the BIOS are current at the time of print, and therefore they may not be exactly the same as that displayed on your screen.

To activate CMOS Setup program, press **DEL** key immediately after you turn on the system. The following message "Press DEL to enter SETUP" should appear in the lower left hand corner of your screen. When you enter the CMOS Setup Utility, the Main Menu will be displayed as **Figure 5-1**. You can use arrow keys to select your function, press **Enter** key to accept the selection and enter the sub-menu.

Figure 5-1 CMOS Setup Utility Main Screen
Phoenix - AwardBIOS CMOS Setup Utility



(This Page is Left for Blank)

(This Page is Left for Blank)

Appendix A <I/O ports pin assignment>

A.1 <IDE Port>

Connector: IDE1

Type: 40-pin (20 x 2) box header



Pin	Description	Pin	Description
1	Reset	2	Ground
3	D7	4	D8
5	D6	6	D9
7	D5	8	D10
9	D4	10	D11
11	D3	12	D12
13	D2	14	D13
15	D1	16	D14
17	D0	18	D15
19	Ground	20	VCC
21	REQ	22	Ground
23	IOW-/STOP	24	Ground
25	IOR-/HDMARDY	26	Ground
27	IORDY/DDMARDY	28	IDESEL
29	DACK-	30	Ground
31	IRQ	32	N/C
33	A1	34	CBLID
35	A0	36	A2
37	CS0 (MASTER CS)	38	CS1 (SLAVE CS)
39	LED ACT-	40	Ground



Connector: IDE2

2

44

Type: 44-pin (22 x 2) box header



Pin	Description	Pin	Description
1	Reset	2	Ground
3	D7	4	D8
5	D6	6	D9
7	D5	8	D10
9	D4	10	D11
11	D3	12	D12
13	D2	14	D13
15	D1	16	D14
17	D0	18	D15
19	Ground	20	N/C
21	REQ	22	Ground
23	IOW-/STOP	24	Ground
25	IOR-/HDMARDY	26	Ground
27	IORDY/DDMARDY	28	Ground
29	DACK-	30	Ground
31	IRQ	32	N/C
33	A1	34	SD
35	A0	36	A2
37	CS1	38	CS3
39	ASP1	40	Ground
41	Vcc	42	Vcc
43	Ground	44	Ground

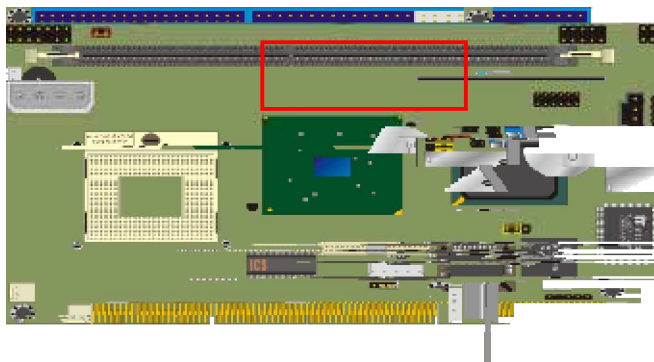

A.2 <Floppy Port>

Connector: FDD

Type: 34-pin (2 x 17) 2.54-pitch header



Pin	Description	Pin	Description
1	Ground	2	DRIVE DENSITY SELECT 0
3	Ground	4	DRIVE DENSITY SELECT 1
5	Ground	6	N/C
7	Ground	8	INDEX-
9	Ground	10	MOTOR ENABLE A-
11	Ground	12	DRIVER SELECT B-
13	Ground	14	DRIVER SELECT A-
15	Ground	16	MOTOR ENABLE B-
17	Ground	18	DIRECTION-
19	Ground	20	STEP-
21	Ground	22	WRITE DATA-
23	Ground	24	WRITE GATE-
25	Ground	26	TRACK 0-
27	Ground	28	WRITE PROTECT-
29	Ground	30	READ DATA-
31	Ground	32	HEAD SELECT-
33	Ground	34	DISK CHANGE-



A.3 < Parallel Port>

Connector: LPT

Type: 26-pin (2 x 13) 2.54-pitch box header



Pin	Description	Pin	Description
1	STROBE-	14	AUTO FEED-
2	D0	15	ERROR-
3	D1	16	INITIALIZE-
4	D2	17	SELECT INPUT-
5	D3	18	Ground
6	D4	19	Ground
7	D5	20	Ground
8	D6	21	Ground
9	D7	22	Ground
10	ACKNOWLEDGE-	23	Ground
11	BUSY	24	Ground
12	PAPER EMPTY	25	Ground
13	SELECT+	26	N/C



A.4 <Serial Port>

A.4.1 <External DB9 COM>

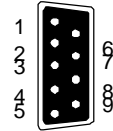

Connector: **COM1**

Type: 9-pin D-sub male connector on bracket

Pin	Description	Pin	Description
1	DCD	6	DSR
2	SIN	7	RTS
3	SO	8	CTS
4	DTR	9	RI
5	Ground		

A.4.2 <Internal COM2>

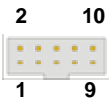

Connector: **CN_COM2**

Type: 10-pin (2 x 5) 2.54-pitch header

Pin	Description	Pin	Description
1	DCD	2	SIN
3	SO	4	DTR
5	Ground	6	DSR
7	RTS	8	CTS
9	RI	10	N/C



A.5 <USB Port>

Connector: **CN_USB**

Type: 10-pin (2 x 5) header for dual USB Ports

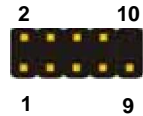

Pin	Description	Pin	Description
1	VCC	2	VCC
3	Data0-	4	Data1-
5	Data0+	6	Data1+
7	Ground	8	Ground
9	Ground	10	N/C

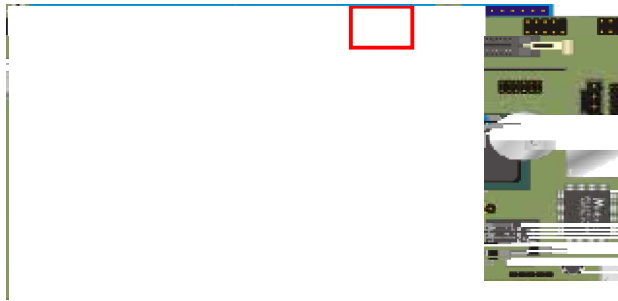

A.6 <IrDA Port>

Connector: **CN_IR**

Type: 5-pin (1 x 5) 2.54-pitch header for SIR Port



Pin	Description
1	VCC
2	N/C
3	IRRXD
4	Ground
5	IRTXD



A.7 <VGA Port>

Connector: **VGA**

Type: 15-pin D-sub female connector on bracket

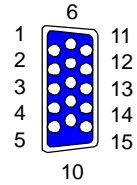

Pin	Description	Pin	Description	Pin	Description
1	RED	6	Ground	11	N/C
2	GREEN	7	Ground	12	5VCCA
3	BLUE	8	Ground	13	HSYNC
4	N/C	9	LVGA5V	14	VSYNC
5	Ground	10	Ground	15	5VCLK

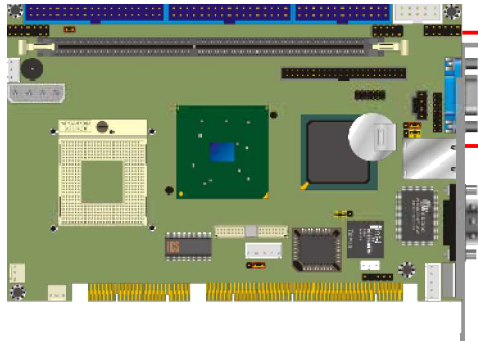

A.8 <LAN Port>

Connector: **RJ45**

Type: RJ45 connector with LED on bracket

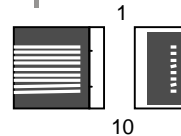

Pin	1	2	3	4	5
Description	TRD0+	TRD0-	TRD1+	TRD1-	NC
Pin	6	7	8	9	10
Description	NC	TRD2+	TRD2-	TRD3+	TRD3-

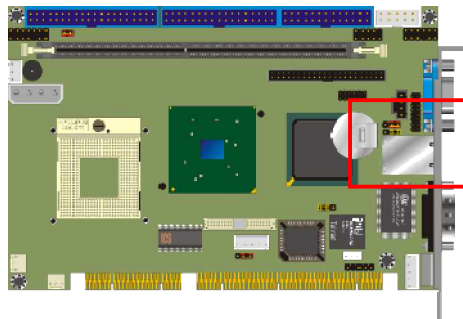

A.9 <AT Keyboard Port>

Connector: **CN_ATKB**
 Type: 5-pin box header

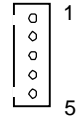

Pin	1	2	3	4	5
Description	CLK	DATA	N/C	Ground	VCC



A.10 <PS/2 Keyboard & Mouse Port>

Connector: **PS2**
 Type: 6-pin Mini-DIN connector on bracket

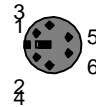

Pin	1	2	3	4	5	6
Description	KBD	MSD	Ground	VCC	KBC	MSC

Note: The PS/2 connector supports standard PS/2 keyboard directly or both PS/2 keyboard and mouse through the PS/2 Y-type cable. The cable is the standard on packing list.

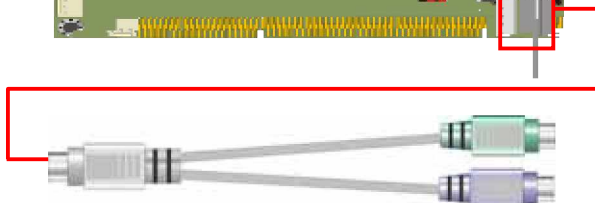
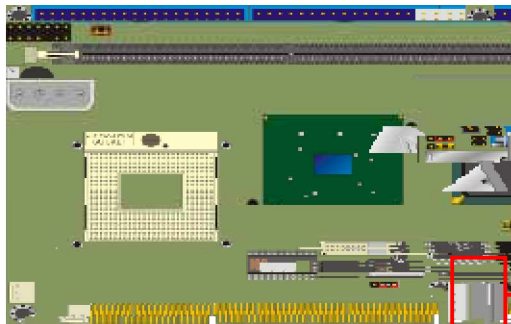

Appendix B <Flash BIOS>

B.1 BIOS Auto Flash Tool

The board is based on Award BIOS and can be updated easily by the BIOS auto flash tool. You can download the tool online at the address below:

<http://www.award.com>

<http://www.commell.com.tw/support/support.htm>

File name of the tool is "awdfash.exe", it's the utility that can write the data into the BIOS flash chip and update the BIOS.

B.2 Flash Method

1. Please make a bootable floppy disk.
2. Get the last .bin files you want to update and copy it into the disk.
3. Copy awardflash.exe to the disk.
4. Power on the system and flash the BIOS. (Example: C:/ awardflash XXX.bin)
5. Re-start the system.

Any question about the BIOS re-flash please contact your distributors or visit the web-site at below:

<http://www.commell.com.tw/support/support.htm>

(This Page is Left for Blank)

(This Page is Left for Blank)

Appendix C <Watchdog Timer Programming Guide>

WDT source from : WinBond 83627HF

(1) General Description

Winbond has a WDT feature inside its chip. We implement its function into our circuit .

There are many configuration Registers (CR) in 83627HF. The following sequence must be followed for CR programming :

- (*1) Enter the extended function mode
- (*2) Configure the configuration registers
- (*3) Exit the extended function mode

EFER : Extended Function Enable Registers.(EFER=2Eh in our system)

EFIR : Extended Function Index Register. (Same addr. with EFER.) EFDR :

Extended Function Data Register.(Located at addr.[EFIR +1])

For instance ;

(*1) Enter extended function mode

```
MOV DX,2EH
MOV AL,87H
CLI           ; disable interrupt
OUT DX,AL
JMP $+2
OUT DX,AL
STI           ; enable interrupt
```

(*2) Configurate logical device 1 , configuration register CRF0

```
MOV DX,2EH
MOV AL,07H
OUT DX,AL
           ; point to Logical Device Number Register
MOV DX,2FH
MOV AL,01H
OUT DX,AL
           ; select logical device 1
MOV DX,2EH
MOV AL,0F0H
OUT DX,AL
MOV DX,2FH
MOV AL,3CH
OUT DX,AL ; update CRF0 of LD0 with value 3Ch
```

(*3) Exit extended function mode

```
MOV DX,2EH
MOV AL,0AAH
OUT DX,AL
```

The Configuration Register (CR) Definition :

- ** Chip (Global) Control Register (CCR) : CR02 -->CR2F.
CR07 = Logical Device Number Register (LDNR)
- ** Logical Device 0 (LD0) = FDC , with CR : CR30 -->CRF5 .
When LDNR (= CR07) = 00h , you can program the CR30 --CRF5 related to FDC feature .
- ** Logical Device 1 (LD1) = Parallel Port,with CR :CR30 -->CRF0.
- ** LD2 = UART A (Serial Port 1) ,with CR :CR30 -->CRF0.
- ** LD3 = UART B (Serial Port 2) ,with CR :CR30 -->CRF1.
- ** LD5 = KBC ,with CR :CR30 -->CRF0.
- ** LD6 = CIR ,with CR :CR30 -->CR70.
- ** LD7 = GAME PORT,MIDI PORT & GP I/O Port I,with CR :CR30 -->CRF2.
- ** LD8 = GP I/O Port II,with CR :CR30 -->CRF7.
- ** LD9 = GP I/O Port III,with CR :CR30 -->CRF3.
- ** LDA = ACPI,with CR :CR30 -->CRFF.
- ** LDB = HARDWARE MONITOR, with CR : CR30 --> CRF0

(2) Related CR for WDT programming

CR2B-Bit 4 ;[0] for WDT function (via Pin89)

LD8-CRF5-Bit 3; Select WDT count time

0 = second.

1 = minute.

LD8-CRF6 ; WDT time-out period ,

00h = disabled

01h = 1 second/minute .

02h = 2 seconds/minutes .

03h = 3 seconds/minutes .

04h = 4 seconds/minutes .

05h = 5 seconds/minutes .

.....

FEh = 254 seconds/minutes .

FFh = 255 seconds/minutes .

When writing a non-zero value to LD8-CRF6 , this value will be loaded into WDT counter and start to count down .Read this register can not get the WDT time-out period (the original one written into) , but the current value in WDT counter .

Enable and Refresh WDT : program LD8-CRF6 a
non-zero value .

Disable WDT : program LD8-CRF2 with 00h .

LD8-CRF7- Bit 4 : WDT Status

1 = WDT time-out happened

0 = WDT counting .

LD8-CRF7- Bit[3..0] : Select IRQ resource for WDT time-out
(Setting of 2 selects SMI)

(3) WDT Programming guide

Step 1 . Enter extended function mode as mentioned as above.

Step 2 . Program WDT related CR.

(2-1) CR2B-b[4]P[0] ; Set pin output as WDT function

(2-2) CR07-P08h ; Point to LD8

(2-3) CRF6-Pxyh

 ; Program WDT time-out period and start

count down . xy = 00 ; No WDT time-out and counting

xy = 01 ; WDT time-out = 30 sec. and starts counting .

.....

(2-4) Read CRF7-b4 if needed ; 0 : WDT counting

 1 : WDT time-out happened

Step 3. Exit extended function mode as mentioned as above.

Example (ENABLE WDT AND SET WDT time-out = 5 minutes)

Step 1 .

```
MOV  DX,2EH
MOV  AL,87H
CLI                         ; disable interrupt
OUT  DX,AL
JMP  $+2
OUT  DX,AL
STI                         ; enable interrupt
```

Step 2 .

```
MOV  DX,2Eh
MOV  AL,2BH
OUT  DX,AL
MOV  DX,2Fh
IN   AL,DX                   ; READ CR2B
AND  AL,0EFH
MOV  AH,AL
```

```
MOV  DX,2Eh
MOV  AL,2BH
OUT  DX,AL
MOV  DX,2Fh
MOV  AL,AH
OUT  DX,AL                   ; CR2B-b[4]P[0]
```

```
MOV  DX,2Eh
MOV  AL,07H
OUT  DX,AL                   ; point to Logical Device Number Register
```

```
MOV DX,2Fh
MOV AL,08H
OUT DX,AL ; select logical device 8
;
MOV DX,2Eh
MOV AL,0F5H
OUT DX,AL
MOV DX,2Fh
IN AL,DX ;
OR AL,08h ; SELECT MINUTE
MOV AH,AL

MOV DX,2Eh
MOV AL,0F5h
OUT DX,AL
MOV DX,2Fh
MOV AL,AH
OUT DX,AL

MOV DX,2Eh ; SETTING 5 MINUTES
MOV AL,0F6h ; ( LD8-CRF6-P05h )
OUT DX,AL
MOV DX,2Fh
MOV AL,05h
OUT DX,AL
```

Step 3 . Exit extended function mode

```
MOV DX,2Eh
MOV AL,0AAH
OUT DX,AL
```

REMARK :

**** I/O PORT 2Eh --> Index port for programming CR .
2Fh --> Data port for programming CR .

**** LD8-CRF6-P05h :

Program CR index F6h of Logical Device 8
with the value "05h" .

Appendix D <Hardware Test>

D.1 <Power Consumption>

Hardware		
CPU	Intel® Mobile Celeron® 1.2GHz	
Memory	UNIGEN DDR333 512MB x 1	
HDD	Seagate ST340014A	(not counted)
CDROM	SONY DDU1621 DVD-ROM	(not counted)
Power Supply	SEVENTEAM ST-402HLP	
Software		
OS	Windows XP SP1 English Version	
Application	3DMARK 2003	
Test Result		
5V	5.42A	27.1W
12V	427mA	5.124W

Contact Information

Any adviser or comment about our products and service, or anything we can help you please don't hesitate to contact with us. We will do our best service for you.



Global American Inc.

Address 17 Hampshire Drive Hudson

NH 03051

USA

TEL 1-603-886-3900

FAX 1-603-886-4545

Website: www.globalamericaninc.com