



integration with integrity

3307421 User's Manual

Full Size PICMG

Version 1.0

Copyrights

This document is copyrighted and all rights are reserved. It does not allow any non authorization in copied, photocopied, translated or reproduced to any electronic or machine readable form in whole or in part without prior written consent from the manufacturer.

In general, the manufacturer will not be liable for any direct, indirect, special, incidental or consequential damages arising from the use of inability to use the product or documentation, even if advised of the possibility of such damages. The manufacturer keeps the rights in the subject to change the contents of this document without prior notices in order to improve the function design, performance, quality and reliability. The author assumes no responsibility for any errors or omissions, which may appear in this document, nor does it make a commitment to update the information contained herein.

Trademarks

Intel is a registered trademark of Intel Corporation.

Award is a registered trademark of Award Software, Inc.

All other trademarks, products and or product's name mentioned herein are mentioned for identification purposes only, and may be trademarks and/or registered trademarks of their respective companies or owners.

Table of Contents

How to Use This Manual

Chapter 1 System Overview	1-1
1.1 Introduction.....	1-1
1.2 Check List	1-2
1.3 Product Specification	1-2
1.3.1 Mechanical Drawing.....	1-6
1.4 System Architecture	1-6
Chapter 2 Hardware Configuration	2-1
2.1 Jumper Setting	2-1
2.2 Connector Allocation	2-2
Chapter 3 System Installation.....	3-1
3.1 Pentium 4 Processor	3-1
3.2 Main Memory	3-2
3.3 M-systems Flash Disk	3-2
3.4 Installing the Single Board Computer	3-3
3.4.1 Chipset Component Driver.....	3-3
3.4.2 Intel Integrated Graphics GMCH Chip	3-3
3.4.3 On-board Fast Ethernet Controller	3-4
3.4.4 On-board AC-97 Audio Device	3-4
3.4.5 On-board 68-pin PCI connector.....	3-4
3.5 Clear CMOS Operation.....	3-5
3.6 WDT Function.....	3-5
3.7 On-Board USB 2.0 Controller.....	3-6
3.8 Panel Display Output (Factory Optional only)	3-7
3.9 GPIO	3-7
Chapter 4 BIOS Setup Information.....	4-1
4.1 Entering Setup.....	4-1
4.2 Main Menu	4-2
4.3 Standard CMOS Setup Menu	4-3
4.4 IDE Adaptors Setup Menu.....	4-5
4.5 Advanced BIOS Feature	4-6
4.6 Advanced Chipset Feature.....	4-9
4.7 Integrated Peripherals	4-12
4.8 Power Management Setup	4-17
4.9 PnP/PCI Configurations	4-21
4.10 PC Health Status	4-24
4.11 Frequency/Voltage Control.....	4-25
4.12 Default Menu	4-25
4.13 Supervisor/User Password Setting	4-26
4.14 Exiting Selection	4-27
Chapter 5 Troubleshooting	5-1
5.1 Backplane Setup.....	5-1
5.2 Onboard Hardware Installation	5-4
5.3 BIOS Setting.....	5-6
5.4 OS Diagnostics	5-7

How to Use This Manual

The manual describes how to configure your 3307421 system to meet various operating requirements. It is divided into five chapters, with each chapter addressing a basic concept and operation of Single Board Computer.

Chapter 1: System Overview. This chapter presents what you have in the inside of box and give you an overview of the product specifications and basic system architecture for this model of single board computer.

Chapter 2: Hardware Configuration Setting. This chapter shows the definitions and locations of Jumpers and Connectors that you can easily configure your system.

Chapter 3: System Installation. This chapter describes how to properly mount the CPU and main memory, M-system Flash disk, or optional flat panel display interface module if any to get a safe installation and give you a programming guide of Watch Dog Timer function. Besides, it will introduce and show you the driver installation procedure about Graphics Controller.

Chapter 4: BIOS Setup Information. This chapter specifies the meaning of each setup parameters and how to get advanced BIOS performance and update new BIOS. In addition, POST checkpoint list will give you a guide of trouble-shooting.

Chapter 5: Troubleshooting. This chapter provides you a few useful tips to quickly get your 3307421 running with no failure. As basic hardware installation has been addressed in Chapter 3, this chapter will basically focus on system integration issues, in terms of backplane setup, BIOS setting, and OS diagnostics.

The content of this manual and EC declaration document is subject to change without prior notice. These changes will be incorporated in new editions of the document.

WARNING

■ Remove Processor

Caution: Do not pull out processor without opening socket handle!

- High viscosity thermal grease between processor and cooler will lead the processor be pulled out from socket when taking cooler off.
- This action may damage processor socket, which will cause poor contact between CPU & socket.

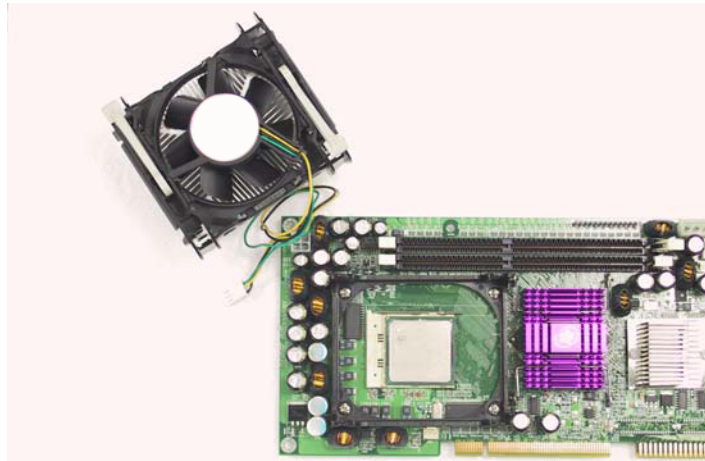

■ Handling SBC

Caution: Do not just hold any single side of the SBC; hold evenly on both sides!

- Heavy processor cooler shall bend the SBC when SBC being held just on one side.
- The bending may cause serious soldering or circuit damage.

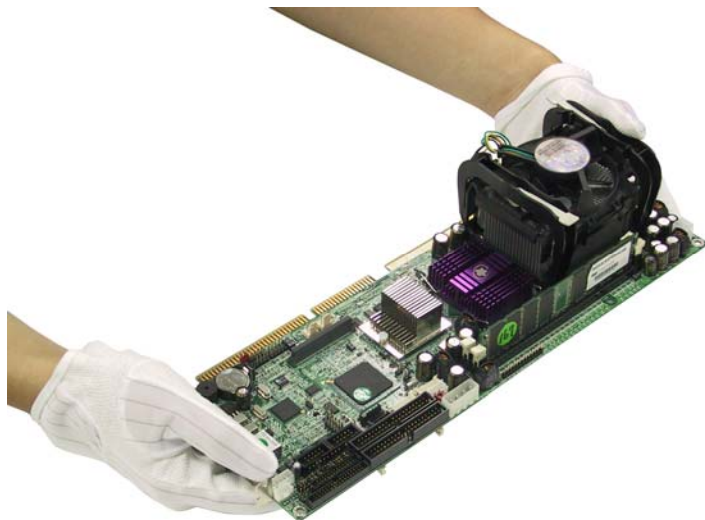

Chapter 1

System Overview

1.1 Introduction

3307421 is a cost effective and high integration Pentium 4 applied computing platform. It provides innovative, high integration, high quality Single Board Computers in the applied computing market. The board is based on Intel 845GV chipset and support Intel latest high performance processor, Intel Socket 478 Pentium® 4 Processor, running at up to 3.06Ghz with 533Mhz Process system bus that built on Intel ® 0.13 micron processor technology.

With Intel 845GV chipset that support high speed non-ECC DDR SDRAM, high-performance graphic controller AGP 4X controller and Intel fast Ethernet connection enable 3307421 to provide most versatile SBC in the market.

3307421 was designed to meet all kind of applied computing application. With Intel most advance mainstream chipset 845GV 3307421 is aiming the most wide range of Multimedia and networking application in the market.

Its proprietary PCI extension connector provides an easy way to add additional functions like U160 SCSI or 2nd LAN device in minutes.

It's compact design with industry PICMG standard form factor make it the best solution for high density server. High reliability and easy-to-maintain nature (lower MTTR) meet high-availability need of Mission critical application.

1.2 Check List

The 3307421 package should cover the following basic items:

- ✓ One 3307421 single board computer
- ✓ One serial port kit with two COM ports
- ✓ One Parallel port cable kit
- ✓ One FDC cable
- ✓ One IDE cable
- ✓ One Y-cable cable for PS/2 keyboard and mouse
- ✓ One 4-pin ATX power control cable for backplane connection
- ✓ One Installation Resources CD-Title
- ✓ CPU holder
- ✓ One booklet of 3307421 manual
- ✓ One Multimedia kit with MIC, Line In, Line Out and Single-port USB connectors (Optional Accessory, not included in standard package)

If any of these items is damaged or missing, please contact your vendor and keep all packing materials for future replacement and maintenance.

1.3 Product Specification

Main Features

- Intel 845GV based PICMG SBC with VGA/LAN/Audio and optional SCSI 160 or 2nd LAN module through proprietary connector (PCI bus)
- Support mPGA478 socket Pentium 4
- PSB speed 400/533 MHz
- Support DDR200/266 DDR SDRAM memory up to 2GB without ECC support
- Intel GMCH integrated graphic device with up to 64MB Dynamic display memory
- ICH4 integrated fast Ethernet controller
- Support two a DMA/33/66/100 IDE
- Support Standard I/O including 2 serial ports, 1parallel port, one IrDA port, 3 USB ports (USB 2.0 compliant) and 8 high driving GPIO.
- Compliant with PCI Bus spec V2.1
- Full-size All-in-one SBC with PICMG 1.0 Rev 2.0 compliant
- Proprietary socket for optional daughter board (PCI bus) for SCSI or 2nd LAN options

System Specifications

- **Chipset**
 - Intel 845GV
 - Intel GMCH and Intel ICH4
- **CPU**
 - Support one mPGA478 socket Pentium 4 Processor up to 3.06GHz
 - PSB speed 400/533 MHz
 - With standard CPU retention for easy heat sink and fan installation
 - 512KB or 256KB L2 Cache Memory Intel® Pentium® 4 or Celeron Processor
- **Main memory**
 - Two 184-pin DIMM sockets
 - Supports 200/266Mhz DDR SDRAM up to 2GB
 - Available bandwidth up to 2.1GB/s (DDR266)
 - 64/128/256/512 MB SDRAM technologies
 - 2.5V DDR SDRAM support
 - Registered DIMM not supported
 - Do not support ECC functionality
- **System BIOS**
 - Phoenix - Award BIOS with PC'98 support
 - 4Mbit flash ROM (Intel FWH) for easy upgrade
 - Support DMI, PnP, Green function and ACPI
 - ACPI support suspend to RAM, USB wake up.
- **On Board I/O**
 - PCI IDE Interface
 - Support two enhanced IDE channel up to four HDDs with PIO mode 4, Ultra DMA/33/66/100 model transfer and Bus master feature.
 - Floppy Drive Interface
 - Support one FDD port up to two floppy drives and 5-1/4"(360K, 1.2MB), 3-1/2" (720K, 1.2MB, 1.44MB, 2.88MB) diskette format and 3-mode FDD
 - Serial Ports
 - Support two high-speed 16C550 compatible UARTs with 16-byte T/R FIFOs RS-232/422/485 selectable for COM2 by jumper
 - IR Interface
 - Support one 6-pin header for serial Standard Infrared wireless communication Shared with one serial port
 - Parallel Port
 - Support one parallel port with SPP, EPP and ECP modes
 - USB Interface
 - USB 2.0 compliant
 - Support three USB (Universal Serial Bus) ports for high-speed I/O peripheral devices
 - One on bracket; two with pin header

- PS/2 Mouse and Keyboard Interface
Support one 6-pin Mini-DIN connector for PS/2 mouse/keyboard connection through Y-Cable separation and one 5-pin shrouded connector for PS/2 keyboard connection through backplane connection
- **Auxiliary I/O**
 - One 2-pin system reset switch
 - One 4-pin external speaker interface
 - One 5-pin key-lock header
 - One 2-pin HDD active indicator interface
 - One 8-pin USB dual port interface
 - One 4-pin ATX power control interface
 - One 10-pin connector for GPIO (4 GPI and 4 GPO)
- **Bracket**
 - Support one RJ45 connectors (LAN)
 - One VGA connector
 - One USB Port
 - One PS/2 Keyboard/mouse connector (Mini din)
- **Hardware Monitoring**
Support CPU voltage, temperature and FAN monitoring
- **Watchdog Timer**
 - Support WDT function through software programming
 - Software programmable time-out internal setting
 - Generate system reset or NMI
- **Solid State Disk (SSD)**
 - Reserved one 32-pin socket for M-systems Flash Disk (Disk-on-Chip,DOC) up to 512MB
 - DOS, Windows, Win95, NT (bootable) drivers and Utility supported
- **Real Time Clock/Calendar (RTC)**
 - Support Y2K Real Time Clock/Calendar with battery backup for 7-year data retention
 - A high quality external Li battery
- ACPI compliant support the full-on (S0), Stop Grant (S1), Suspend to RAM (S3), Suspend to Disk (S4), and soft-off (S5) power management states.
- **ATX Power Control Interface**
One 4-pin header to support ATX power control with Modem Ring-On and Wake-On-LAN function
- **Auxiliary I/O Interfaces**
System reset switch, external speaker, Keyboard lock and HDD active LED, etc.
- **Power Good**
On-Board power good generator with 200 ms to 300 ms reset duration
- **CPU Cooling Fan**
Support one 3-pin header with wafer

Additional Main Peripheral Function

- On Board High performance Graphics (Intel GMCH Integrated Graphics controller)
 - IGD with analog display port
 - Analog Display Support up to 2048 x 1536 @ 60Hz refresh
 - AGP 2.0, AGP 4X. 1.5V
 - Software DVD at 30 fps, full screen
 - Motion Video Acceleration
- One On Board Ethernet (one ICH4 Integrated MAC controller with external 10/100 Mb phy)
 - Support 10/100 MB Base-TX
 - One RJ-45 phone jack.
 - Support two LEDs to indicator LAN access and link status on RJ45 jack
 - Support Wake-on-LAN
- PICMG Compliant PCI plus ISA bus Interface
 - Follow PICMG 1.0 Rev 2.0 standard (32-bit PCI and 16-bit ISA)
 - Fully complies with PCI Local Bus specification V2.1 (support 4 master PCI slots)
- On Board PCI to ISA Bridge
 - Support ISA Bus mastering
 - Support standard ISA slot
 - 64mA high driving
 - Support M-system DOC
- ISA64 High ISA-Bus Driving Capability
Support 64mA high driving capability for ISA-Bus slots on back plane
- On-board 68-pin PCI connector
Support one additional PCI daughter board
- Optional daughter Board Ultra 160 SCSI (AIC 7892 chipset)
 - Support Proprietary PCI connector
 - Support one 68-pin SCSI interface
 - SCSI data transfers up to 160MB/sec
- Physical and Environmental requirements
 - Outline Dimension (L x W) 338.5mm (13.33") X 122mm (4.8")
 - Power Requirements:
 - . +12V (CPU) @4.0A
 - . +12V (System) @0.8A
 - . +5V @2.8A
 - Test configuration:
 - . CPU: Intel P4 2.4GHz/533MHz FSB/512KB L2 Cache
 - . Memory: DDR SDRAM 512MBx2
 - . Primary Master IDE HDD: Samsung SV2042H (20GB)
 - . OS: Microsoft Windows 2000 + SP2

- . Test Programs: 3D Mark 2001 for loading VGA and Burning Test V2.2 for loading CPU
- . Connected Fans: Only CPU fan connected
- . Run Time: 10 minutes
- Operating Temperature: 0°C ~ 55°C (32°F ~ 131°F)
- Storage Temperature: -20°C ~ 80°C
- Relative Humidity: 0% ~ 95%, non-condensing

1.3.1 Mechanical Drawing

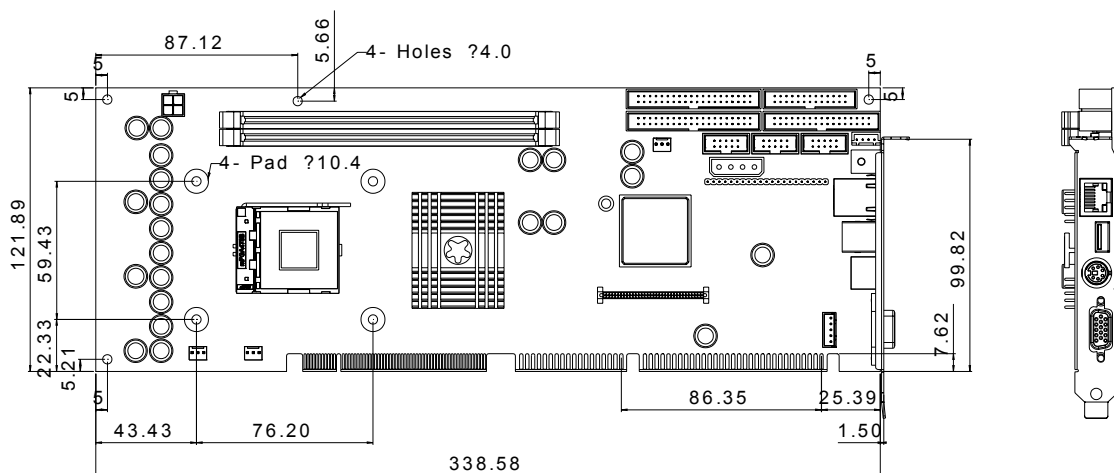

1.4 System Architecture

The system architecture of 3307421 includes two main Intel chips, Intel 845GV chipset supports Pentium-4/Celeron processor, DDR-SDRAM, 2D/3D graphic display, and its ICH4 supports PCI bus interface, APM, ACPI compliant power management, USB port, SMBus communication, and Ultra DMA/33/66/100 IDE Master, and it also provides a Fast Ethernet controller. The W83627HF (I/O Controller) is responsible for PS/2 Keyboard/Mouse, UARTs, FDC, Hardware Monitor, Parallel, Watch Dog Timer and Infrared interface.

The special pin configuration of the CPU socket adopts the 478 pins in total. This new generation CPU provides better performance to many applications.

The PCI-to-ISA bridge supports a standard 16-bit ISA bus interface which is applied for all slower I/O operations. In 3307421, it supports DiskOnChip (DOC) for M-systems Flash disk.

There is one on-board PCI Fast Ethernet via RJ-45 Ports to support full functionality of 3307421 AIO SBC (All-In-One Single Board Computer).

The on-board 68-pin PCI connector supports one additional PCI daughter board for further extension.

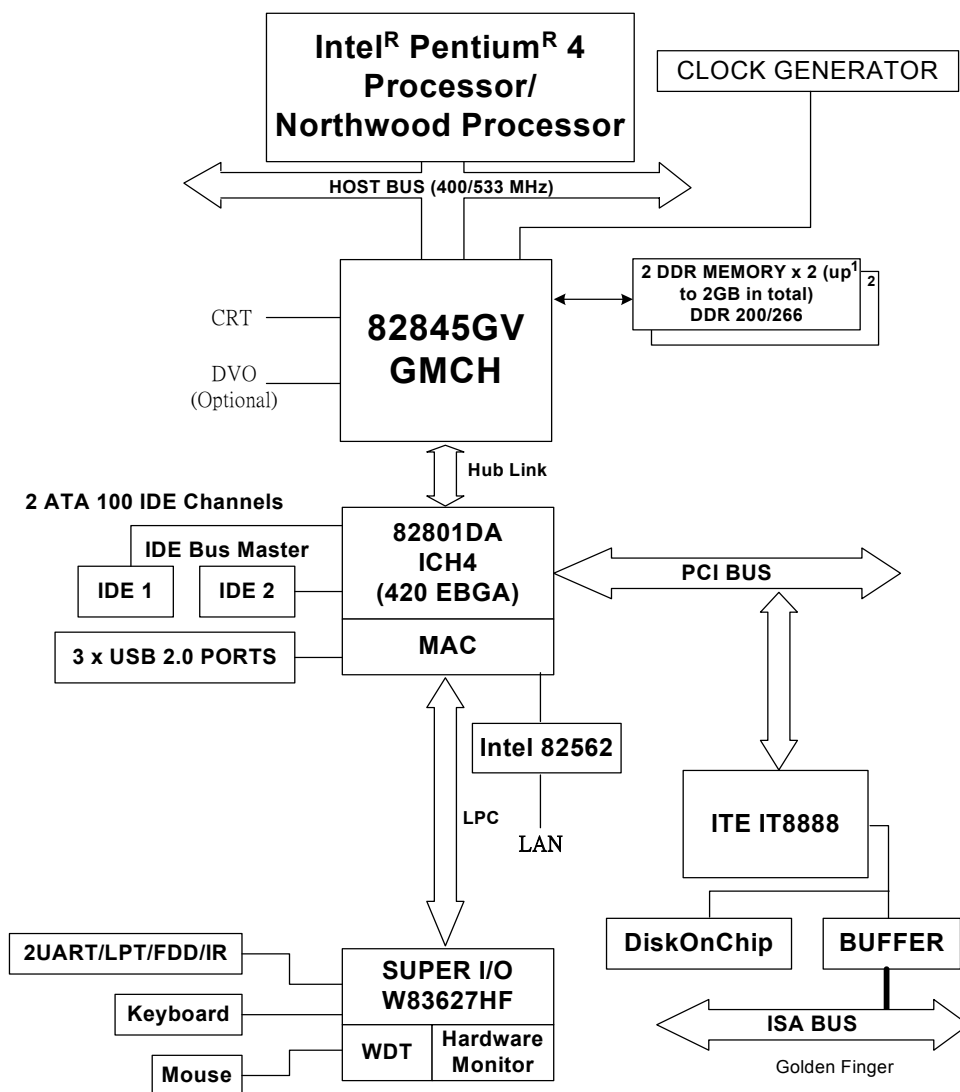

3307421 System Block Diagram

Chapter 2 Hardware Configuration

This chapter indicates jumpers', headers' and connectors' locations. Users may find useful information related to hardware settings in this chapter. The default settings are indicated with a star sign (★).

2.1 Jumper Setting

For users to customize 3307421 features. In the following sections, Short means covering a jumper cap over jumper pins; Open or N/C (Not Connected) means removing a jumper cap from jumper pins.

Users can refer to Figure 2-1 for the Jumper locations.

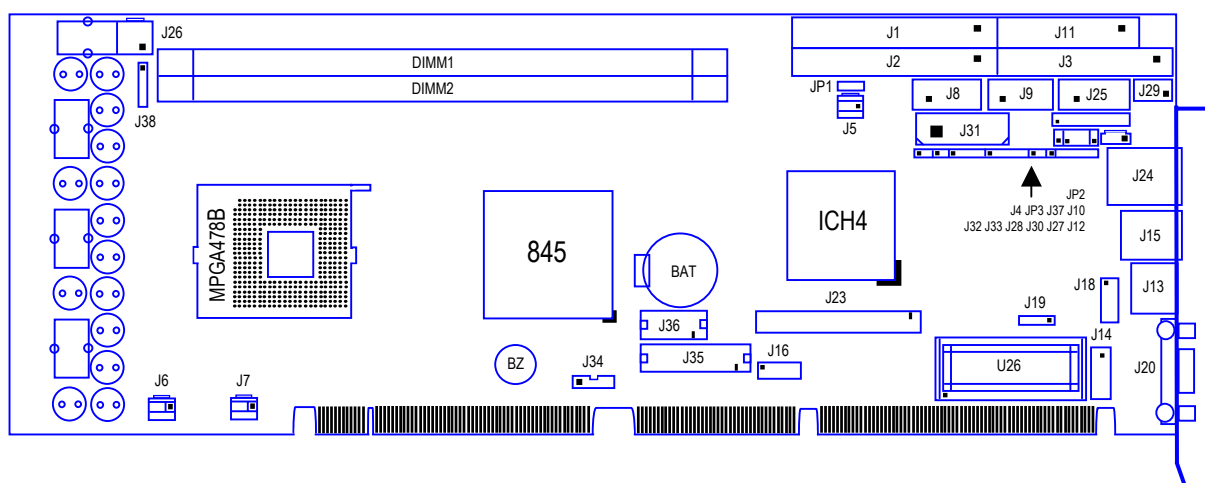

Figure 2-1 3307421 Jumper/Connector Location

JP1: CMOS Clear

JP1	Function
1-2 Short	Normal Operation ★
2-3 Short	Clear CMOS / Contents

JP2: COM2(J9) Interface Selection

JP2	
5-6,9-11,10-12,15-17,16-18 Short	RS-232 ★
3-4,7-9,8-10,13-15,14-16,21-22 Short	RS-422
1-2,7-9,8-10,19-20 Short	RS-485

JP3: AT/ATX Power Selection

JP3	
1-3, 2-4 Short	AT Power
3-5,4-6 Short	ATX Power ★

2.2 Connector Allocation

I/O peripheral devices and flash disk are connected to the interface connectors and DOC socket on this single board computer (Figure 2-1)

Connector's Function List

Connector	Function	Remark
J1	Primary IDE Connector (IDE1)	
J2	Secondary IDE Connector (IDE2)	
J3	FDC Interface Connector	
J5	Power FAN Connector	
J6	CPU Fan Connector	
J7	System Fan Connector	
J8	COM1 Serial Port (RS-232)	
J9	COM2 Serial Port (RS-232/422/485)	
J10	External Wake On LAN Connector	
J11	Parallel Port Connector	
J12	IrDA Connector	
J13	PS/2 keyboard/Mouse Connector	6-pin Mini-DIN
J14	External keyboard Connector	Connect to Backplane
J15	Single-port USB Connector	
J16	External USB Connector	
J18	Audio MIC/Line-in/Line-out	
J19	Audio CD-in Connector	
J20	On-board VGA CRT Connector	
J23	68-pin PCI Connector	
J24	Ethernet RJ-45 Connector	
J25	General Purpose I/O Connector	
J26	12V CPU Power Connector	Must to connect
J27	Hard Disk Drive LED Connector	Connect to Chassis
J28	External Speaker Connector	Connect to Chassis
J29	ATX Power Control Connector	Connect to Backplane
J30	Power LED and Keyboard Lock	Connect to Chassis
J31	Standalone Power Connector	Only for standard one
J32	ATX Power Button Interface	Connect to Chassis
J33	Reset Button Connector	Connect to Chassis
J34	DVO Power Connector	Optional
J35	DVO Connector -1	Optional
J36	DVO Connector -2	Optional
J38	Front SMBus Connector	

Pin Assignments of Connectors

J1/J2: Primary/Secondary IDE Connector (IDE1/IDE2)

PIN No.	Signal Description	PIN No.	Signal Description
1	RESET#	2	Ground
3	Data 7	4	Data 8
5	Data 6	6	Data 9
7	Data 5	8	Data 10
9	Data 4	10	Data 11
11	Data 3	12	Data 12
13	Data 2	14	Data 13
15	Data 1	16	Data 14
17	Data 0	18	Data 15
19	Ground	20	N/C
21	DMA REQ	22	Ground
23	IOW#	24	Ground
25	IOR#	26	Ground
27	IOCHRDY	28	Pull-down
29	DMA ACK#	30	Ground
31	INT REQ	32	N/C
33	DA1	34	CBLID#
35	DA0	36	DA2
37	HDC CS0#	38	HDC CS1#
39	HDD Active#	40	Ground

J3: FDC Interface Connector

PIN No.	Signal Description	PIN No.	Signal Description
1	Ground	2	Density Select 0
3	Ground	4	N/C
5	Ground	6	Density Select 1
7	Ground	8	Index#
9	Ground	10	Motor ENA#
11	Ground	12	Drive Select B#
13	Ground	14	Drive Select A#
15	Ground	16	Motor ENB#
17	Ground	18	Direction#
19	Ground	20	Step#
21	Ground	22	Write Data#
23	Ground	24	Write Gate#
25	Ground	26	Track 0#
27	Ground	28	Write Protect#

29	N/C	30	Read Data#
31	Ground	32	Head Select#
33	N/C	34	Disk Change#

J5/J6/J7 : Power/CPU/System Fan Connector

PIN No.	Signal Description
1	Ground
2	+12V
3	Fan Speed Detecting signal

Note:

The fan must be a 12V fan. And there is not any over current protection.

J8/J9: COM1/COM2 Serial Port 1/2 Connector

PIN No.	Signal Description		
	RS-232	RS-422	RS-485
1	DCD (Data Carrier Detect)	TX-	DATA-
2	RXD (Receive Data)	TX+	DATA+
3	TXD (Transmit Data)	RX+	N/C
4	DTR (Data Terminal Ready)	RX-	N/C
5	GND (Ground)	GND	GND
6	DSR (Data Set Ready)	N/C	N/C
7	RTS (Request to Send)	N/C	N/C
8	CTS (Clear to Send)	N/C	N/C
9	RI (Ring Indicator)	N/C	N/C
10	N/C	N/C	N/C

Notes:

- 1) J8 is fixed as RS-232
- 2) J9 is configurable as RS-232/422/485 with jumper JP2

J10: External Wake On LAN Connector

PIN No.	Signal Description
1	5VSB
2	Ground
3	External WOL Signal Input (Active low)

J11: Parallel Port Connector

PIN No.	Signal Description	PIN No.	Signal Description
1	Strobe#	14	Auto Form Feed#
2	Data 0	15	Error#
3	Data 1	16	Initialization#
4	Data 2	17	Printer Select IN#
5	Data 3	18	Ground
6	Data 4	19	Ground
7	Data 5	20	Ground
8	Data 6	21	Ground
9	Data 7	22	Ground
10	Acknowledge#	23	Ground
11	Busy	24	Ground
12	Paper Empty	25	Ground
13	Printer Select	26	N/C

J12: IrDA Connector

PIN No.	Signal Description
1	+5V
2	N/C
3	IRRX
4	Ground
5	IRTX
6	N/C

J13: PS/2 Keyboard/Mouse Connector

PIN No.	Signal Description
1	Mouse Data
2	Keyboard Data
3	Ground
4	5V Dual
5	Mouse Clock
6	Keyboard Clock

J14: External Keyboard Connector

PIN No.	Signal Description
1	Keyboard Clock
2	Keyboard Data
3	N/C
4	Ground
5	5V Dual

J15: Single-port USB Connector

PIN No.	Signal Description
1	5V Dual
2	USB0-
3	USB0+
4	Ground

J16: External USB Connector

PIN No.	Signal Description	PIN No.	Signal Description
1	5V Dual	2	Frame Ground
3	USB2-	4	Ground
5	USB2+	6	USB3+
7	Ground	8	USB3-
9	Frame Ground	10	5V Dual

Note:

5V Dual is always available. It's supplied by either 5V VCC power source in normal operation mode or 5V standby power source in standby mode.

J18: Audio MIC/Line-in/Line-out Connector

PIN No.	Signal Description	PIN No.	Signal Description
1	MIC with Reference Voltage	2	Analog Ground
3	Line-in Left Channel	4	Analog Ground
5	Line-in Right Channel	6	Analog Ground
7	Line-out Left Channel	8	Analog Ground
9	Line-out Right Channel	10	N/C

Note:

The Reference Voltage on MIC signal offers 2.25V~2.75V with 5mA drive

J19: Audio CD-in Connector

PIN No	Signal Description
1	CD-in Left Channel
2	CD Ground
3	CD Ground
4	CD-in Right Channel

J20: On-board VGA CRT Connector

PIN No.	Signal Description
1	Red
2	Green
3	Blue
4	Monitor ID0 (MONID0) (5V I/F)
5	Ground
6	Ground
7	Ground
8	Ground
9	N/C
10	Ground
11	Monitor ID1 (MONID1) (5V I/F)
12	VGA DDC Data (5V I/F)
13	Horizontal Sync. (HSYNC) (5V I/F)
14	Vertical Sync. (VSYNC) (5V I/F)
15	VGA DDC Clock (5V I/F)

J23: 68-pin PCI Connector

PIN No.	Signal Description	PIN No.	Signal Description
1	+5V	2	AD0
3	AD1	4	AD2
5	AD3	6	AD4
7	AD5	8	AD6
9	AD7	10	Ground
11	+5V	12	AD8
13	AD9	14	AD10
15	AD11	16	AD12
17	AD13	18	AD14
19	AD15	20	Ground
21	+5V	22	AD16
23	AD17	24	AD18
25	AD19	26	AD20
27	AD21	28	AD22
29	AD23	30	Ground
31	+5V	32	AD24
33	AD25	34	AD26
35	AD27	36	AD28
37	AD29	38	AD30
39	AD31	40	Ground
41	+5V	42	C/BE#0
43	C/BE#1	44	C/BE#2
45	C/BE#3	46	PAR
47	FRAME#	48	TRDY#
49	IRDY#	50	Ground
51	+5V	52	STOP#
53	DEVSEL#	54	PERR#
55	SERR#	56	REQ#4
57	GNT#4	58	REQ#5
59	GNT#5	60	Ground
61	PCI Clock1	62	PCI Clock2
63	PCIRST#	64	LOCK#
65	IRQ#A	66	IRQ#B
67	IRQ#C	68	IRQ#D

J24: Ethernet RJ-45 Connector

PIN No.	Signal Description
1	TD+
2	TD-
3	TDC
4	Termination to Ground
5	Termination to Ground
6	RDC
7	RD+
8	RD-

J25: General Purpose I/O Connector

PIN No.	Signal Description
1	General Purpose I/O Port 1 (GPIO1)
2	General Purpose I/O Port 2 (GPIO2)
3	General Purpose I/O Port 3 (GPIO3)
4	General Purpose I/O Port 4 (GPIO4)
5	Ground
6	Buffered Digital Output Port 1 (DO1)
7	Buffered Digital Output Port 2 (DO2)
8	Buffered Digital Output Port 3 (DO3)
9	Buffered Digital Output Port 4 (DO4)
10	+5V

Notes:

- 1) All General Purpose I/O ports can only adapt standard TTL $\pm 5\%$ signal level (0V/5V). Pin 1~4 can be either input or output, while pin 6-10 can only be digital output.
- 2) The 4 extra DO ports are provided for the applications that need higher driving capability. Through invert amplitude respected to GPIO port, each open-drain DO port can stand maximum fan out for up to 100mA, rather than 12mA direct driven by GPIO port.

J26: 12V CPU Supplementary Connector

PIN No.	Signal Description
1	Ground
2	Ground
3	+12V
4	+12V

J27: Hard Disk Drive LED Connector

PIN No.	Signal Description
1	+5V (390 ohm pull-up for HDD LED+)
2	HDD Active # (HDD LED-)

J28: External Speaker Connector

PIN No.	Signal Description
1	Speaker Signal Output (Open-drain w/ internal series 33 Ohm)
2	N/C
3	Ground
4	+5V

Note:

The pull-high voltage of external speaker is limited at 5V maximum.

J29: ATX Power Control Connector

PIN No.	Signal Description
1	ATX Power Good Signal (PW-OK)
2	ATX 5V Stand-by (5VSB)
3	ATX Power On Control (PS-ON)
4	Ground

J30: Power LED and Keyboard Lock Connector

PIN No.	Signal Description
1	+5V (470 Ohm pull-up for power LED+)
2	N/C
3	Ground (For Power LED-)
4	Keyboard Lock Signal Input (Active low)
5	Ground

J31: Standalone Power Connector

PIN No.	Signal Description
1	+12V
2	Ground
3	Ground
4	+5V

Notes:

- 1) To run system in standalone operation. Both J26 and J31 have to be connected.
- 2) Some of USB 2.0 devices need large current consumption. It is helpful for them to detect by system while Standalone Power connector is connected on SBC.

J32: ATX Power button Interface

PIN No.	Signal Description
1	Pull-high 1K Ohm to +5V
2	Power Button Signal Input (Active high)

J33: Reset Button Connector

PIN No	Signal Description
1	Reset Signal Input (Active low)
2	Ground

J34: DVO Power Connector

PIN No.	Signal Description
1	+12V
2	+5V
3	+3.3V
4	Ground
5	Ground

J35: DVO Connector-1 (Factory Optional for Panel Display Kit only); not populated with standard module

PIN No.	Signal Description	PIN No.	Signal Description
1	DVOCD0	2	DVOCD1
3	DVOCD2	4	DVOCD3
5	DVOCD4	6	DVOCD5
7	DVOCD6	8	DVOCD7
9	DVOCD8	10	DVOCD9
11	DVOCD10	12	DVOCD11
13	DVOCCLK	14	DVOCCLK#
15	DVOCVSYNC	16	DVOCHSYNC
17	DVOCFLDSTL	18	DVOCBLANK#
19	DVOBCCLKINT	20	DVOBCINTR#
21	Ground	22	+3.3V
23	MDDC_CLK	24	MDDC_DATA
25	MI2CCLK	26	MI2CDATA
27	MDVI_CLK	28	MDVI_DATA
29	Ground	30	+5V
31	ADDIN0	32	ADDIN1
33	ADDIN2	34	ADDIN3
35	ADDIN4	36	ADDIN5
37	ADDIN6	38	ADDIN7
39	CHIPRST-	40	+1.5V

J36: DVO Connector-2 (Factory Optional for Panel Display Kit only); not populated on the standard module

PIN No.	Signal Description	PIN No.	Signal Description
1	DVOBD0	2	DVOBD1
3	DVOBD2	4	DVOBD3
5	DVOBD4	6	DVOBD5
7	DVOBD6	8	DVOBD7
9	DVOBD8	10	DVOBD9
11	DVOBD10	12	DVOBD11
13	DVOBCLK	14	DVOBCLK#
15	DVOBVSNC	16	DVOBHSYNC
17	DVOBFLDSTL	18	DVOBCCLKINT
19	Ground	20	+3.3V

J38: Front SMBus Connector

PIN No.	Signal Description
1	SMBCLK
2	N/C
3	Ground
4	SMBDATA
5	+5V

Chapter 3

System Installation

This chapter provides you with instructions to set up your system. The additional information is enclosed to help you install M-systems Flash disk, set up onboard PCI device and handle WDT operation in software programming.

3.1 Pentium 4 Processor

Installing 478 Pin CPU

- 1) Lift the handling lever of CPU socket outwards and upwards to the other end.
- 2) Align the processor pins with pinholes on the socket. Make sure that the notched corner or dot mark (pin 1) of the CPU corresponds to the socket's bevel end. Then press the CPU gently until it fits into place. If this operation is not easy or smooth, don't do it forcibly. You need to check and rebuild the CPU pin uniformly.
- 3) Push down the lever to lock processor chip into the socket once CPU fits.
- 4) Follow the installation guide of cooling fan or heat sink to mount it on CPU surface and lock it on the socket 478.

Note:

You should know Pentium 4 processor need extra 12V power source. DON'T FORGET TO CONNECT 4pin 12V connector to J26!

Removing CPU

- 1) Unlock the cooling fan first.
- 2) Lift the lever of CPU socket outwards and upwards to the other end.
- 3) Carefully lift up the existing CPU to remove it from the socket.
- 4) Follow the steps of installing a CPU to change to another one or place handling bar to close the opened socket.

Configuring System Bus

3307421 will automatically detect the CPU used. CPU speed of Intel P4 can be detected automatically.

3.2 Main Memory

3307421 provides two DDR-SDRAM DIMM slots to support 2.5V DDR-SDRAM as on-board main memory. The maximum memory size can be up to 2GB. Auto detecting memory clock according to BIOS CMOS settings.

For system compatibility and stability, don't use memory module without brand. You can also use only one double-sided DIMM in either one DIMM slot or two single-sided DIMM in both slots.

Watch out the contact and lock integrity of memory module with socket, it will impact on the system reliability. Follow normal procedures to install your DRAM module into memory socket. Before locking, make sure that all modules have been fully inserted into the card slots.

Note:

To maintain system stability, don't change any of DRAM parameters in BIOS setup to upgrade your system performance without acquiring technical information.

3.3 M-systems Flash Disk

3307421 reserves one 32-pin DIP sockets for installing M-systems Flash disk from 2MB to 288MB. This operation structure is running with pure ISA-bus without PnP (Plug and Play) function. Before installing, make sure that I/O address jumper setting is set on right position to prevent unworkable system due to I/O resource conflict. Do remember to follow DOC (DiskOnChip) installation procedure. Otherwise, it is possible to burn out the Flash chip due to incorrect installation.

Installing DOC

Align the DOC with pinholes on the socket. Make sure that the notched corner or dot mark (pin 1) of DOC corresponds to notched corner of the socket. Then press the DOC gently until it fits into place. If installation procedure is correct, the Flash disk can be viewed as a normal hard disk to access read/write data.

3.4 Installing the Single Board Computer

To install your 3307421 into standard chassis or proprietary environment, you need to perform the following:

Step 1 : Check all jumpers setting on proper position

Step 2 : Install and configure CPU and memory module on right position

Step 3 : Place 3307421 into the dedicated position in your system

Step 4 : Attach cables to existing peripheral devices and secure it

WARNING

Please ensure that your SBC is properly inserted and fixed by mechanism. Otherwise, the system might be unstable or do not work due to bad contact of PICMG 1.0 PCI plus ISA-bus slot.

Note:

Please refer to section 3-4-1 to 3-4-3 to install INF/VGA/LAN drivers.

3.4.1 Chipset Component Driver

The chipset on 3307421 is a new chipset that a few old operating systems might not be able to recognize. To overcome this compatibility issue, for Windows Operating Systems such as Windows-95/98/98SE/2000, please install its INF before any of other Drivers are installed. You can find very easily this chipset component driver in 3307421 CD-title.

3.4.2 Intel Integrated Graphics GMCH Chip

Using GMCH High performance graphic integrated chipset is aimed to gain an outstanding graphic performance. It is accompanied by shared 8 to 64MB system DDR-SDRAM with Intel DVMT. This combination makes 3307421 an excellent piece of multimedia hardware.

With no additional video adaptor, this onboard video will usually be the system display output. By adjusting the BIOS setting to disable on-board VGA, an add-on PCI or ISA VGA card can take over the system display.

Drivers Support

Please find 845G/GV GMCH driver in the 3307421 CD-title. Drivers support Windows-98/98SE/ME, Windows-NT 3.51/4.0, Windows-2000, OS2, and Linux.

(1) Windows-98/98SE: Please execute exe file to start graphics driver installation, or bring up the Display Control Panel and update graphics driver.

- (2) Windows-NT 4.0: Please install Windows-NT 4.0 Service Pack 4 or above first, then execute exe file, or simply bring up the Display Control Panel and update graphics driver.
- (3) Windows-2000: Please bring up the Device Manager and update graphics drivers.
- (4) Redhat Linux V6.2: Please refer to the related documentation in for graphic drivers installation.

3.4.3 On-board Fast Ethernet Controller

Drivers Support

Please find Intel ICH4 LAN driver in /Ethernet directory of 3307421 CD-title. The drivers support Windows-NT 4.0, Windows-98/98SE/ME, Windows-2000, Windows-XP, and Linux.

LED Indicator (for LAN status)

3307421 provides three LED indicators to report 82801BA MAC Fast Ethernet interfaces status. Please refer to the table below as a quick reference guide.

82801BA	Name of LED	Operation of Ethernet Port	
		ON	Off
Amber	LAN Linked & Active LED	Linked	Active (Blinking)
Green	LAN speed LED	100 Mbps	10 Mbps

3.4.4 On-board AC-97 Audio Device

The on-board AC-97 audio device provides a more than standard sound display. It is capable for many general purposes.

3.4.5 On-board 68-pin PCI connector

3307421 provides one on-board 68-pin PCI connector that allows you to apply additional PCI devices, such as SCSI or Ethernet. If you have a compatible PCI device, simply plug it onto the connector and secure it with two retention bars.

3.5 Clear CMOS Operation

The following table indicates how to enable/disable CMOS Clear Function hardware circuit by putting jumpers at proper position.

JP1	Function
1-2 Short	Normal Operation ★
2-3 Short	Clear CMOS contents

To correctly operate CMOS Clear function, users must turn off the system, move JP1 jumper to short pin 2 and 3. To clear CMOS contents, please turn the power back on and turn it off again for AT system, or press the toggle switch a few times for ATX system. Move the JP1 back to 1-2 position (Normal Operation) and start the system. System will then produce a “CMOS Check Sum Error” message and hold up. Users may then follow the displayed message to load BIOS default setting.

3.6 WDT Function

The working algorithm of the WDT function can be simply described as a counting process. The Time-Out Interval can be set through software programming. The availability of the time-out interval settings by software or hardware varies from boards to boards.

3307421 allows users to control the WDT through dynamic software programming. The WDT starts counting when it is activated. It sends out a signal to system reset or to non-maskable interrupt (NMI), when time-out interval ends. To prevent the time-out interval from running out, a re-trigger signal will need to be sent before the counting reaches its end. This action will restart the counting process. A well-written WDT program should keep the counting process running under normal condition. WDT should never generate a system reset or NMI signal unless the system runs into troubles.

The related Control Registers of WDT are all included in the following sample program that is written in C language. User can fill a non-zero value into the Time-out Value Register to enable/refresh WDT. System will be reset after the Time-out Value to be counted down to zero. Or user can directly fill a zero value into Time-out Value Register to disable WDT immediately. To ensure a successful accessing to the content of desired Control Register, the sequence of following program codes should be step-by-step run again when each register is accessed.

Additionally, there are maximum 2 seconds of counting tolerance that should be considered into user' application program. For more information about WDT, please refer to Winbond W83627HF data sheet.

There are two PNP I/O port addresses that can be used to configure WDT,
 1) 0x2E:EFIR (Extended Function Index Register, for identifying CR index number)
 2) 0x2F:EFDR (Extended Function Data Register, for accessing desired CR)

Below are some example codes, which demonstrate the use of WDT.

```
// Enter Extended Function Mode
outp(0x002E, 0x87);
outp(0x002E, 0x87);
// Assign Pin 89 to be a WDIO
outp(0x002E, 0x2B);
outp(0x002F, inp(0x002F) & 0xEF);
// Select Logic Device 8
outp(0x002E, 0x07);
outp(0x002F, 0x08);
// Active Logic Device 8
outp(0x002E, 0x30);
outp(0x002F, 0x01);
// Select Count Mode
outp(0x002E, 0xF5);
outp(0x002F, (inp(0x002F) & 0xF7) | (Count-mode Register & 0x08));
// Specify Time-out Value
outp(0x002E, 0xF6);
outp(0x002F, Time-out Value Register);
// Disable WDT reset by keyboard/mouse interrupts
outp(0x002E, 0xF7);
outp(0x002F, 0x00);
// Exit Extended Function Mode
outp(0x002E, 0xAA);
```

Definitions of Variables:

Value of **Count-mode Register**:

- 1) 0x00 -- Count down in seconds (Bit3=0)
- 2) 0x08 -- Count down in minutes (Bit3=1)

Value of **Time-out Value Register**:

- 1) 0x00 -- Time-out Disable
- 2) 0x01~0xFF -- Value for counting down

3.7 On-Board USB 2.0 Controller

Drivers Support

Please find Intel ICH4 USB driver in /USB20 directory of 3307421 CD-title.
 The drivers support Windows-2000 and Windows-XP.

3.8 Panel Display Output (Factory Optional only)

This is a factory optional function through a proprietary VDO connector and a 5-pin shouted header for power control/source of backlight system.

There are two LCD panel interfaces can provided in this system, TMDS and LVDS are two interfaces available on different panel kit.

A connection to one of these 2 different interfaces will result different signal line impedance combinations. The selection will be made base on the different impedances combinations.

3.9 GPIO

The 3307421 provides 4 input/output ports that can be individually configured to perform a simple basic I/O function. Users can configure each individual port to become an input or output port by programming register bit of I/O Selection. To invert port value, the setting of Inversion Register has to be made. Port values can be set to read or write through Data Register.

Additionally, 4-extra Digital Output ports inversely amplified signals from GPIO ports. There are open-drain buffers, which can offer greater driving capacity up to 100mA.

There are two PNP I/O port addresses that can be used to configure GPIO ports,

- 1) 0x2E - EFER (Extended Function Enable Register, for entering Extended Function Mode)
 - EFIR (Extended Function Index Register, for identifying CR index number)
- 2) 0x2F - EFDR (Extended Function Data Register, for accessing desired CR)

Below are some example codes, which demonstrate the use of GPIOs.

```
// Enter Extended Function Mode
outp(0x002E, 0x87);
outp(0x002E, 0x87);
// Assign Pin121-128 to be GPIO port 1
outp(0x002E, 0x2A);
outp(0x002F, inp(0x002F) | 0x84);
// Select Logic Device 7
outp(0x002E, 0x07);
outp(0x002F, 0x07);
// Active Logic Device 7
outp(0x002E, 0x30);
```



```

outp(0x002F, 0x01);
// Select Inversion Mode
outp(0x002E, 0xF2);
outp(0x002F, (inp(0x002F) & 0x0F) | (Inversion Register & 0xF0));
// Select I/O Mode
outp(0x002E, 0xF0);
outp(0x002F, (inp(0x002F) & 0x0F) | (I/O Selection Register & 0xF0));
// Access GPIO ports
outp(0x002E, 0xF1);
outp(0x002F, (inp(0x002F) & 0x0F) | (Output Data & 0xF0));
or
Input Data = inp(0x002F);
// Exit Extended Function Mode
outp(0x002E, 0xAA);

```

Definitions of Variables:

Each bit in the high nibble of each Register represents the setting of a GPIO port.

- Bit4 vs. GPIO port 1
- Bit5 vs. GPIO port 2
- Bit6 vs. GPIO port 3
- Bit7 vs. GPIO port 4

Value of **Inversion Register**:

Only high nibble is available for this function.

When set to a '1', the incoming/outgoing port value is inverted.

When set to a '0', the incoming/outgoing port value is the same as in Data Register.

Value of **I/O Selection Register**:

Only high nibble is available for this function.

When set to a '1', respective GPIO port is programmed as an input port.

When set to a '0', respective GPIO port is programmed as an output port.

Value of **Output Data**/**Input Data**:

Only high nibble is available for this function.

If a port is assigned to be an output port, then its respective bit can be read/written.

If a port is assigned to be an input port, then its respective bit can be read only.

Notes:

- 1) All the Buffered Digital Outputs are open-drain amplified form corresponding GPIO ports.
- 2) Some other functions may occupy the lower nibble of the registers. Altering any content in lower nibble will be undesired.

Chapter 4

BIOS Setup Information

3307421 is equipped with the AWARD BIOS stored in Flash ROM. This BIOS has a built-in Setup program that allows users to modify the basic system configuration easily. This type of information is stored in CMOS RAM so that it is retained during power-off periods. When system is turned on, 3307421 communicates with peripheral devices and check its hardware resources against the configuration information stored in the CMOS memory. If any error is detected, or the CMOS parameters need to be initially defined, the diagnostic program will prompt the user to enter the SETUP program. Some errors are significant enough to abort the start-up.

4.1 Entering Setup

Turn on or reboot the computer. When the message "Hit if you want to run SETUP" appears, press key immediately to enter BIOS setup program.

If the message disappears before you respond, but you still wish to enter Setup, please restart the system to try "COLD START" again by turning it OFF and then ON, or touch the "RESET" button. You may also restart from "WARM START" by pressing <Ctrl>, <Alt>, and <Delete> keys simultaneously. If you do not press the keys at the right time and the system will not boot, an error message will be displayed and you will again be asked to,

Press <F1> to Run SETUP or Resume

In HIFLEX BIOS setup, you can use the keyboard to choose among options or modify the system parameters to match the options with your system. The table below will show you all of keystroke functions in BIOS setup.

General Help	
↑ ↓ → ←	: Move
Enter	: Select
+ / - /PU /PD	: Value
ESC	: Exit
F1	: General Help
F2	: Item Help
F5	: Previous Values
F6	: Fail-Safe Defaults
F7	: Optimized Defaults
F9	: Menu in BIOS
F10	: Save

4.2 Main Menu

Once you enter 3307421 AWARD BIOS CMOS Setup Utility, you should start with the Main Menu. The Main Menu allows you to select from eleven setup functions and two exit choices. Use arrow keys to switch among items and press <Enter> key to accept or bring up the sub-menu.

Phoenix- AwardBIOS CMOS Setup Utility

<ul style="list-style-type: none"> ▶ Standard CMOS Features ▶ Advanced BIOS Features ▶ Advanced Chipset Features ▶ Integrated Peripherals ▶ Power Management Setup ▶ PnP/PCI Configurations ▶ PC Health Status 	<ul style="list-style-type: none"> ▶ Frequency/Voltage Control Load Fail-Safe Defaults Load Optimized Defaults Set Supervisor Password Set User Password Save & Exit Setup Exit Without Saving
<p>ESC : Quit F9 : Menu in BIOS ↑ ↓ → ← : Select Item F10 : Save & Exit Setup</p>	
<p>Time, Date, Hard Disk Type ...</p>	

Note:

It is strongly recommended to reload Optimal Setting if CMOS is lost or BIOS is updated.

4.3 Standard CMOS Setup Menu

This setup page includes all the items in a standard compatible BIOS. Use the arrow keys to highlight the item and then use the <PgUp>/<PgDn> or <+>/<-> keys to select the value or number you want in each item and press <Enter> key to certify it.

Follow command keys in CMOS Setup table to change **Date**, **Time**, **Drive type**, and **Boot Sector Virus Protection Status**.

Phoenix- AwardBIOS CMOS Setup Utility
Standard CMOS Features

Date (mm:dd:yy)	Thu, Nov 28 2002	Item Help
Time (hh:mm:ss)	2 : 29 : 50	
▶ IDE Primary Master		Menu Level ▶
▶ IDE Primary Slave		
▶ IDE Secondary Master		Change the day, month, year and century
▶ IDE Secondary Slave		
Drive A	[1.4M, 3.5 in.]	
Drive B	[None]	
Floppy 3 Mode Support	[Disabled]	
Video	[EVG/VGA]	
Halt On	[All, But Keyboard]	
Base Memory	640K	
Extended Memory	65472K	
Total Memory	1024K	
↑↓→←: Move Enter: Select +/-/PU/PD: Value F10: Save ESC: Exit F1: General Help F5: Previous Values F6: Fail-Safe Defaults F7: Optimized Defaults		

■ **Menu Selections**

Item	Options	Description
Date	mm:dd:yy	Change the day, month, year and century
Time	hh:mm:ss	Change the internal clock
IDE Primary Master	Options are in its sub menu (described in 4.4 Table)	Press <Enter> to enter the sub menu of detailed options
IDE Primary Slave	Options are in its sub menu (described in 4.4 Table)	Press <Enter> to enter the next page for detail hard drive settings

IDE Secondary Master	Options are in its sub menu (described in 4.4 Table)	Press <Enter> to enter the next page for detail hard drive settings
IDE Secondary Slave	Options are in its sub menu (described in 4.4 Table)	Press <Enter> to enter the next page for detail hard drive settings
Drive A Drive B	None 360K, 5.25 in 1.2M, 5.25 in 720K, 3.5 in 1.44M, 3.5 in 2.88M, 3.5 in	Press <Enter> to enter the next page for detail hard drive settings
Video	EGA/VGA CGA 40 CGA 80 MONO	Select the default video device
Halt On	All Errors No Errors All, but Keyboard All, but Diskette All, but Disk/Key	Select the situation in which you want the BIOS to stop the POST process and notify you
Base Memory	N/A	Displays the amount of conventional memory detected during boot up
Extended Memory	N/A	Displays the amount of extended memory detected during boot up
Total Memory	N/A	Displays the total memory available in the system

4.4 IDE Adaptors Setup Menu

The IDE adaptors control the IDE devices, such as hard disk drive or cdrom drive. It uses a separate sub menu to configure each hard disk drive.

Phoenix- AwardBIOS CMOS Setup Utility
IDE Primary Master

IDE HDD Auto-Detection	Press Enter	Item Help
IDE Primary Master	Auto	Menu Level ▶ To auto-detect the HDD's size, head ... on this channel
Access Mode	Auto	
Capacity	20491 MB	
Cylinder	39703	
Head	16	
Precomp	0	
Landing Zone	39702	
Sector	63	
↑↓→←: Move Enter: Select +/-/PU/PD: Value F10: Save ESC: Exit F1: General Help F5: Previous Values F6: Fail-Safe Defaults F7: Optimized Defaults		

■ Menu Selections

Item	Options	Description
IDE HDD Auto-detection	Press Enter	Press Enter to auto-detect the HDD on this channel. If detection is successful, it fills the remaining fields on this menu.
IDE Primary Master	None Auto Manual	Selecting 'manual' lets you set the remaining fields on this screen. Selects the type of fixed disk. "User Type" will let you select the number of cylinders, heads, etc. Note: PRECOMP=65535 means NONE !
Access Mode	CHS LBA Large Auto	Choose the access mode for this hard disk
Capacity	Auto Display your disk drive size	Disk drive capacity (Approximated). Note that this size is usually slightly greater than the size of a formatted disk given by a disk checking program.

The following options are selectable only if the 'IDE Primary Master' item is set to 'Manual'		
Cylinder	Min = 0 Max = 65535	Set the number of cylinders for this hard disk.
Head	Min = 0 Max = 255	Set the number of read/write heads
Precomp	Min = 0 Max = 65535	**** Warning: Setting a value of 65535 means no hard disk
Landing zone	Min = 0 Max = 65535	****
Sector	Min = 0 Max = 255	Number of sectors per track

4.5 Advanced BIOS Feature

This section allows you to configure your system for basic operation. You have the opportunity to select the system's default speed, boot-up sequence, keyboard operation, shadowing and security.

Phoenix- AwardBIOS CMOS Setup Utility
Advanced BIOS Features

Virus Warning [Disabled] CPU L1 & L2 Cache [Enabled] Quick Power On Self Test [Enabled] First Boot Device [HDD-0] Second Boot Device [HDD-1] Third Boot Device [Floppy] Boot Other Device [Enabled] Swap Floppy Drive [Disabled] Boot up Floppy Seek [Enabled] Boot up NumLock Status [On] Gate A20 Option [Fast] Typematic Rate Setting [Disabled] X Typematic Rate (Chars/Sec) 6 X Typematic Delay (Msec) 250 Security Option [Setup] APIC Mode [Enable] MPS Version Control For OS [1.4] OS Select For DRAM > 64MB [Non-OS2] Report No FDD For WIN 95 [No] Small Logo(EPA) Show [Disabled]	Item Help <hr/> Menu Level ► Allows you to choose the VIRUS warning feature for IDE Hard Disk boot sector protection. If this function is enabled and someone attempt to write data into this area, BIOS will show a warning message on screen and alarm beep
↑↓→←: Move Enter: Select +/-/PU/PD: Value F10: Save ESC: Exit F1: General Help F5: Previous Values F6: Fail-Safe Defaults F7: Optimized Defaults	

Virus Warning

Allows you to choose the VIRUS warning feature for IDE Hard Disk boot sector protection. If this function is enabled and someone attempt to write data into this area, BIOS will show a warning message on screen and alarm beep.

Enabled	Activates automatically when the system boots up causing a warning message to appear when anything attempts to access the boot sector or hard disk partition table.
Disabled	No warning message will appear when anything attempts to access the boot sector or hard disk partition table.

CPU L1 Cache/L2 Cache

These two categories speed up memory access. However, it depends on CPU/chipset design.

Enabled	Enable cache
Disabled	Disable cache

Quick Power On Self Test

Allows the system to skip certain tests while booting. This will decrease the time needed to boot the system.

Enabled	Enable quick POST
Disabled	Normal POST

First/Second/Third/Other Boot Device

Select your boot device priority.

The choice: Floppy, LS120, HDD-0, SCSI, CDROM, HDD-1, HDD-2 HDD3, ZIP/100, USB-FDD, USB-ZIP, USB-CDROM, USB-HDD, LAN and Disabled.

Swap Floppy Drive

If the system has two floppy drives, choose enable to assign physical driver B to logical drive A and Vice-Versa.

The choice: Enabled, Disabled.

Boot Up Floppy Seek

Enabled tests floppy drives to determine whether they have 40 or 80 tracks

The choice: Enabled, Disabled.

Boot Up NumLock Status

Select power on state for NumLock.

The choice: Off, On.

Gate A20 Option

Fast-lets chipsets control Gate A20 and Normal – a pin in the keyboard controller controls Gate A20. Default is Fast.

The choice: Normal, Fast.

Typematic Rate Setting

Keystrokes repeat at a rate determined by the keyboard controller – When enabled, the typematic rate and typematic delay can be selected.

The choice: Enabled, Disabled.

Typematic Rate (Chars/sec)

The rate at which character repeats when you hold down a key.

The choice: 6, 8, 10, 12, 15, 20, 24, 30.

Typematic delay (Msec)

The delay before key strokes begin to repeat.

The choice: 250, 500, 750, 1000.

Security Option

Select whether the password is required every time the system boots or only when you enter setup.

System	The system will not boot and access to Setup will be denied if the correct password is not entered at the prompt.
Setup	The system will boot, but access to Setup will be denied if the correct password is not entered at the prompt.

OS Select For DRAM > 64MB

Select OS/2 only if you are running SO/2 operating system with greater than 64MB of RAM on the system.

The choice: Non-OS2, OS2.

Report No FDD for WIN 95

The choice: No, Yes.

Small Logo (EPA) Show

The choice: Enabled, Disabled.

4.6 Advanced Chipset Feature

This section allows you to configure the system based on the specific features of the Intel 82845GV chipset. This chipset manages bus speeds and access to system memory resources, such as DRAM (DDR SDRAM) and the external cache. It also coordinates communications between the conventional ISA bus and the PCI bus. It must be stated that these items should never need to be altered. The default settings have been chosen because they provide the best operating conditions for your system. The only time you might consider making any changes would be if you discovered that data was being lost while using your system.

Phoenix- AwardBIOS CMOS Setup Utility
Advanced Chipset Features

	Item Help
DRAM Timing Selectable [By SPD]	
X CAS Latency Time [2.5]	
X Active to Precharge Delay [6]	
X DRAM RAS# to CAS# Delay [3]	
X DRAM RAS# Precharge [3]	
Memory Frequency For [Auto]	
System BIOS Cacheable [Enabled]	
Video BIOS Cacheable [Enabled]	
Memory Hole At 15M-16M [Disabled]	
Delayed Transaction [Enabled]	
Delay Prior to Thermal [16 Min]	
AGP Aperture Size (MB) [64]	
** On-Chip VGA Setting **	
On-Chip VGA [Enabled]	
On-Chip Frame Buffer Size [8MB]	
Boot Display [Auto]	
Onboard LAN Control [Enabled]	
↑↓→←: Move Enter: Select +/-/PU/PD: Value F10: Save ESC: Exit F1: General Help F5: Previous Values F6: Fail-Safe Defaults F7: Optimized Defaults	

This chipset settings deal with CPU access to dynamic random access memory (DRAM). The default timings have been carefully chosen and should only be altered if data is being lost. Such a scenario might well occur if your system had mixed speed DRAM chips installed so that greater delays may be required to preserve the integrity of the data held in the slower memory chips.

DRAM Timing Selectable

This option provides DIMM plug-and-play support by serial presence detect (SPD) mechanism via the system management bus (SMBUS) interface.

The choice: Manual, By SPD.

CAS Latency Time

This option controls the number of SCLKs between the time a read command is sampled by the SDRAMs and the time the GMCH samples correspondent data from the SDRAMs.

The choice: 1.5, 2, 2.5 SCLKs.

Active to Precharge Delay

This is to DDR standard accordingly.

The choice: 7, 6, 5.

DRAM RAS# to CAS# Delay

This option controls the number of SCLKs (SDRAM Clock) from a row activate command to a read or write command. If your system installs good quality of SDRAM, you can set this option to "3 SCLKs" to obtain better memory performance. Normally, the option will be set to Auto.

The choice: 2 or 3.

DRAM RAS# Precharge

This option controls the number of SCLKs for RAS# precharge. If your system installs good quality of SDRAM, you can set this option to "3 SCLKs" to obtain better memory performance. It is set to auto normally.

The choice: 2 or 3.

Memory Frequency For

Users are recommended to use Auto for memory frequency selection.

The choice: DDR200, DDR266, Auto.

System BIOS Cacheable

Selecting Enabled allows caching of the system BIOS ROM at F0000h-FFFFFh, resulting in better system performance. However, if any program writes to this memory area, a system error may result.

The choice: Enabled, Disabled.

Video BIOS Cacheable

Select "Enabled" to enable caching VGA BIOS into L2 cache to get higher display performance. "Disabled" to ignore this BIOS caching function.

The choice: Enabled, Disabled.

Memory Hole At 15-16M

In order to improve performance, certain space in memory is reserved for ISA cards. This memory must be mapped into the memory space below 16MB.

The choice: Enabled, Disabled.

Delayed Transaction

Select "Enabled" to enable delay transaction. This will enhance performance for data transmission between different PCI bus.

The choice: Enabled, Disabled.

Delay Prior to Thermal

The choice: 4 Min, 8 Min, 16 Min, 32 Min.

AGP Aperture Size (MB)

The choice: 4, 8, 16, 32, 64, 128, 256.

On-Chip VGA

The choice: Enabled, Disabled.

On-Chip Frame Buffer Size

Users can set the display memory size that shared from main memory.

The choice: 1MB, 8MB.

Boot Display

The choice: Auto, CRT, TV, EFP.

On board LAN Control

Users can disable on board LAN function.

The choice: Enabled, Disabled.

4.7 Integrated Peripherals

Phoenix- AwardBIOS CMOS Setup Utility
Integrated Peripherals

On-Chip Primary PCI IDE	[Enabled]	Item Help
IDE Primary Master PIO	[Auto]	
IDE Primary Slave PIO	[Auto]	Menu Level ▶
IDE Primary Master UDMA	[Auto]	
IDE Primary Slave UDMA	[Auto]	
On-Chip Secondary PCI IDE	[Enabled]	
IDE Secondary Master PIO	[Auto]	
IDE Secondary Slave PIO	[Auto]	
IDE Secondary Master UDMA	[Auto]	
IDE Secondary Slave UDMA	[Auto]	
USB Controller	[Enabled]	
USB 2.0 Controller	[Enabled]	
USB Keyboard Support	[Enabled]	
USB Mouse Support	[Disabled]	
AC97 Audio	[Auto]	
Init Display First	[PCI Slot]	
IDE HDD Block Mode	[Enabled]	
POWER ON Function	[BUTTON ONLY]	
KB Power ON Password	[Enter]	
Hot Key Power ON	[Ctrl-F1]	
Onboard FDC Controller	[Enabled]	
Onboard Serial Port 1	[Auto]	
Onboard Serial Port 2	[Auto]	
UART Mode Select	[Normal]	
RxD, TxD Active	[Hi,Lo]	
IR Transmission Delay	[Enabled]	
UR2 Duplex Mode	[Half]	
Use IR Pins	[IR-Rx2Tx2]	
Onboard Parallel Port	[378/IRQ7]	
Parallel Port Mode	[SPP]	
EPP Mode Select	[EPP1.7]	
ECP Mode Use DMA	[3]	
PWRON After PWR-Fail	[Off]	
Midi Port Address	[330]	
Midi Port IRQ	[10]	
Watch Dog Timer Select	[Disabled]	
DOC Memory Address Range	[D8000-D9FFF]	
↑↓→←: Move Enter: Select +/-/PU/PD: Value F10: Save ESC: Exit F1: General Help F5: Previous Values F6: Fail-Safe Defaults F7: Optimized Defaults		

OnChip Primary/Secondary PCI IDE

The chipset contains a PCI IDE interface with support for two IDE channels. Select Enabled to activate the primary IDE interface. Select Disabled to deactivate this interface.

The choice: Enabled, Disabled.

IDE Primary/Secondary Master/Slave PIO

The four IDE PIO (Programmed Input/Output) fields let you set a PIO mode (0-4) for each of the four IDE devices that the onboard IDE interface supports. Modes 0 through 4 provide successively increased performance. In Auto mode, the system automatically determines the best mode for each device.

The choice: Auto, Mode 0, Mode 1, Mode 2, Mode 3, Mode 4.

IDE Primary/Secondary Master/Slave UDMA

Ultra DMA/33/66/100 implementation is possible only if your IDE hard drive supports it and the operating environment includes a DMA driver (Windows 95 OSR2 or a third-party IDE bus master driver). If your hard drive and your system software both support Ultra DMA/33/66/100, select Auto to enable BIOS support.

The choice: Auto, Disabled.

USB Controller

This item allows you to enable/disable USB (Universal Serial Bus) function.

The choice: Enabled, Disabled.

USB 2.0 Controller

This item allows you to enable USB 2.0 controller as to provide high speed USB 2.0 devices connection.

The choice: Enabled, Disabled.

USB Keyboard Support

This item allows you to enable USB keyboard function under POST, BIOS setup menu, DOS, or Windows-NT with no USB driver loaded.

The choice: Enabled, Disabled.

USB Mouse Support

This item allows you to enabled USB Mouse function under POST, BIOS Setup menu, DOS, or Window-NT with no USB driver loaded.

The choice: Enabled, Disabled.

AC97 Audio

This item allows you to enable AC97 Audio function.

The choice: Disabled, Auto.

Init Display First

This item allows you to select the first display port to be initialized.

The choice: PCI Slot, Onboard.

IDE HDD Block Mode

If your IDE hard drive supports block mode select Enabled for automatic detection of the optimal number of block read/writes per sector the drive can support.

The choice: Enabled, Disabled.

Power On Function

This item allows you to select different power on scheme using ATX power supply.

Password	Power on using customized password string
Hot Key	Power on using special customized key
Mouse Left	Power on using mouse left click
Mouse Right	Power on using mouse right click
Any Key	Power on using any keyboard key
Button Only	Power on by power Button
Keyboard 98	Power on by keyboard 98 [Only power ON/OFF key]

Keyboard Power On Password

In the event of "Power On Function" being configured as "Password", this item will be enabled for tuning. Press "Enter" key to enter a customized password, and confirm again when being asked. In the case that the confirmed password does not match the configured one, the message of "Password Disabled - Press any key to continue..." will be prompted.

Hot Key Power On

In the event of "Power On Function" being configured as "Hot Key", this item will be enabled for tuning.

The choice: Ctrl-F1 to Ctrl-F12.

Onboard FDC Controller

This item allows you to enable/disable onboard Floppy disk controller.

The choice: Enabled, Disabled.

Onboard Serial Port 1/Port 2

Select an address and corresponding interrupt for the first and second serial ports.

The choice: 3F8/IRQ4, 2E8/IRQ3, 3E8/IRQ4, 2F8/IRQ3, Disabled, Auto.

UART Mode Select

This item allows users to select Infrared transmission mode.

Normal	Disable Infrared function
IrDA	Select IrDA mode transmission
ASKIR	Select ASKIR mode transmission

As Infrared transmission function shares onboard serial port 2, COM2 needs to be enabled.

RxD, TxD Active

This item is to configure Infrared transmission rate. Four options are available :

Hi, Hi	High rate for receiving / High rate for transmitting
Hi, Lo	High rate for receiving / Low rate for transmitting
Lo, Hi	Low rate for receiving / High rate for transmitting
Lo, Lo	Low rate for receiving / Low rate for transmitting

IR Transmission Delay

This option will be available when IR is enabled.

The choice: Enabled, Disabled.

UR2 Duplex Mode

The available choices are full duplex mode and half duplex mode

The choice: Full, Half.

Use IR Pins

The available choices are IR-Rx2Tx2/ RxD2, TxD2.

The choice: IR-Rx2Tx2 / RxD2, TxD2.

Onboard Parallel Port

This item allows you to configure I/O address of the onboard parallel port.

The choice: Disabled, 378/IRQ7, 278/IRQ5, 3BC/IRQ7.

Parallel Port Mode

There are four different modes for the onboard parallel port :

SPP	Switch to SPP mode
EPP	Switch to EPP mode
ECP	Switch to ECP mode
ECP + EPP	Switch to ECP + EPP mode
Normal	Switch to Normal mode

EPP Mode Select

Select different version of EPP mode.

The choice: EPP1.7, EPP1.9.

ECP Mode Use DMA

Select a proper DMA channel for ECP mode.

The choice: 3, 1.

PWRON After PWR-Fail

This item allows user to configure the power status of using ATX power supply after a serious power loss occurs.

On	System automatically restores power back
Off	System stays at power -off
Former-Sts	System restores back to previous status (On or Off)

Midi Port Address

There are 4 choices. There are Disabled, 330, 300 and 290.

The choice: Disabled, 330, 300, 290.

Midi Port IRQ

To assign an IRQ number to Midi Port.

The choice: 5, 10.

Watch Dog Timer Select

This BIOS testing option is able to reset the system according to the selected table.

The choice: Disabled, 10 Sec, 20 Sec, 30 Sec, 40 Sec, 1 Min, 2 Min, 4 Min.

DOC Memory Address Range

There are 4 section option in the memory available to be selected.

The choice: D8000-D9FFF, DA000-DBFFF, DC000-DDFFF and DE000-DFFFF.

4.8 Power Management Setup

The Power Management Setup allows you to configure you system to most effectively save energy while operating in a manner consistent with your own style of computer use.

Phoenix- AwardBIOS CMOS Setup Utility
Power Management Setup

	Item Help	
ACPI Function [Enabled]		
ACPI Suspend Type [S1(POS)]		
X Run VGABIOS if S3 Resume [No]	Menu Level ▶	
Power Management [User Define]		
Video Off Method [DPMS]		
Video Off In Suspend [Yes]		
Suspend Type [Stop Grant]		
Suspend Mode [Disabled]		
HDD Power Down [Disabled]		
Soft-Off by PWR-BTTN [Instant-Off]		
CPU THRM-Throttling [50.0%]		
Wake-up by On Board LAN [Disabled]		
Power On by Ring [Enabled]		
X USB KB Wake-Up From S3 Disabled		
Resume by Alarm [Disabled]		
X Date(of Month) Alarm 0		
X Time(hh:mm:ss) Alarm 0 : 0 :0		
** Reload Global Timer Events **		
Primary IDE 0 [Disabled]		
Primary IDE 1 [Disabled]		
Secondary IDE 0 [Disabled]		
Secondary IDE 1 [Disabled]		
FDD,COM,LPT Port [Disabled]		
PCI PIRQ[A-D]# [Disabled]		
↑↓→←: Move Enter: Select +/-/PU/PD: Value F10: Save ESC: Exit F1: General Help F5: Previous Values F6: Fail-Safe Defaults F7: Optimized Defaults		

ACPI Function

This item allows you to enable/disable the Advanced Configuration and Power Management (ACPI).

The choice: Enabled, Disabled.

ACPI Suspend Type

To decide which ACPI suspend mode to use.

The choice: S1(POS), S3(STR).

Run VGA BIOS if S3 Resume

The choice: Auto, Yes, No.

Power Management

This category allows you to select the type (or degree) of power saving and is directly related to "HDD Power Down", "Suspend Mode".

There are three selections for Power Management, three of which have fixed mode settings.

Min. Power Saving	Minimum power management. Suspend Mode = 1 Hour, and HDD Power Down = 15 Min.
Max. Power Saving	Maximum power management. Suspend Mode = 1 Min., and HDD Power Down = 1 Min.
User Defined	Allows you to set each mode individually. When not disabled, Suspend Mode ranges from 1 min. to 1 Hour and HDD Power Down ranges from 1 Min. to 15 Min.

Video Off Method

This determines the manner in which the monitor is blanked.

V/H SYNC+Blank	This selection will cause the system to turn off the vertical and horizontal synchronization ports and write blanks to the video buffer.
Blank Screen	This option only writes blanks to the video buffer.
DPMS	Initial display power management signaling.

Video Off In Suspend

This allows user to enable/disable video off in Suspend Mode.

The choice: Yes, No.

Suspend Type

Two options are available : Stop Grant and PwrOn Suspend.

The choice: Stop Grant, PwrOn Suspend.

Suspend Mode

When enabled and after the set time of system inactivity, all devices except the CPU will be shut off.

The choice: Disabled, 1 Min, 2 Min, 4 Min, 8 Min, 12 Min, 20 Min, 30 Min, 40 Min, 1 Hour.

HDD Power Down

When enabled and after the set time of system inactivity, the hard disk drive will be powered down while all other devices remain active.

The choice: Disabled, 1 Min, 2 Min, 3 Min, 4 Min, 5 Min, 6 Min, 7 Min, 8 Min, 9 Min, 10 Min, 11 Min, 12 Min, 13 Min, 14 Min, 15 Min.

Soft-Off by PWR-BTTN

This item allows users to set the time to remove the power after the power button is pressed.

The choice: Instant-Off, Delay 4 Sec.

CPU THRM-Throttling

When the CPU temperature reaches the preset standard. The CPU usage will be reduced to a selected level to avoid overheating.

The choice: 87.5%, 75.5%, 62.5%, 50.0%, 37.5%, 25.0%, 12.5%.

Wake-Up by On Board LAN

This option can be enabled to support Wake Up by on-board LAN.

The choice: Disabled, Enabled.

Power On by Ring

When select "Enabled", a system that is at soft-off mode will be alert to Wake-On-Modem signal.

The choice: Enabled, Disabled.

USB KB Wake-up From S3

The choice: Enabled, Disabled.

Resume by Alarm

This item allows users to enable/disable the resume by alarm function. When “Enabled” is selected, system using ATX power supply could be powered on if a customized time and day is approached.

The choice: Enabled, Disabled.

Date(of Month) Alarm

When “Resume by Alarm” is enabled, this item could allow users to configure the date parameter of the timing dateline on which to power on the system.

The choice: 0 ~ 31.

Time(hh:mm:ss) Alarm

When “Resume by Alarm” is enabled, this item could allow users to configure the time parameter of the timing dateline on which to power on the system.

The choice: hh (0~23), mm (0~59), ss (0 ~59).

Primary/Secondary IDE 0/1

This item is to configure IDE devices being monitored by system so as to keep system out of suspend mode if the associated device is busy.

The choice: Enabled, Disabled.

FDD, COM, LPT Port

This item is to configure floppy device, COM ports, and parallel port being monitored by system so as to keep system out of suspend mode if the associated device is busy.

The choice: Enabled, Disabled.

PCI PIRQ[A-D]#

This option can be used to detect PCI device activities. If they are activities, the system will go into sleep mode.

The choice: Enabled, Disabled.

4.9 PnP/PCI Configurations

This section describes configuring the PCI bus system. PCI, or **Personal Computer Interconnect**, is a system which allows I/O devices to operate at speeds nearing the speed the CPU itself uses when communicating with its own special components.

This section covers some very technical items and it is strongly recommended that only experienced users should make any changes to the default settings.

Phoenix- AwardBIOS CMOS Setup Utility PnP/PCI Configurations

PnP OS Installed	[No]	Item Help
Reset Configuration Data	[Disabled]	
Resources Controlled By	[Auto(ESCD)]	Menu Level ▶
X IRQ Resources	Press Enter	Select Yes if you are using a Plug and Play capable operating system Select No if you need the BIOS to configure non-boot devices
X DMA Resources	Press Enter	
PCI/VGA Palette Snoop	[Disabled]	
Assign IRQ For VGA	[Enabled]	
INT Pin 1 Assignment	[Auto]	
INT Pin 2 Assignment	[Auto]	
INT Pin 3 Assignment	[Auto]	
INT Pin 4 Assignment	[Auto]	
INT Pin 5 Assignment	[Auto]	
INT Pin 6 Assignment	[Auto]	
INT Pin 7 Assignment	[Auto]	
INT Pin 8 Assignment	[Auto]	
↑↓→←: Move Enter: Select +/-/PU/PD: Value F10: Save ESC: Exit F1: General Help F5: Previous Values F6: Fail-Safe Defaults F7: Optimized Defaults		

PNP OS Installed

Select Yes if you are using a plug and play capable operating system , select No if you need to BIOS to configure non-boot devices.

The choice: No, Yes.

Reset Configuration Data

Default is Disabled. Select Enabled to reset Extended System Configuration Data (ESCD) when you exit Setup if you have installed a new add-on and the system reconfiguration has caused such a serious conflict that the OS cannot boot.

The choice: Enabled, Disabled.

Resource Controlled By

BIOS can automatically configure all the boot and plug and play compatible devices. If you choose Auto, you cannot select IRQ DMA and memory base address fields, since BIOS automatically assigns them.

The choice: Auto (ESCD), Manual.

IRQ Resources

When resources are controlled manually, assign each system interrupt a type, depending on the type of device using the interrupt.

The choice: Press Enter.

IRQ-3/IRQ-4/IRQ-5/IRQ-7/IRQ-9/IRQ-10/IRQ-11/IRQ-12/IRQ-14/IRQ-15 assigned to.

The choice: PCI/ISA PnP, Legacy ISA.

DMA Resources

When resources are controlled manually, assign each system DMA channel a type, depending on the type of device using the DMA channel.

Enter for more options DMA-0/DMA-1/DMA-3/DMA-5/DMA-6/DMA-7.

The choice: PCI/ISA PnP, Legacy ISA.

PCI/VGA Palette Snoop

Legacy ISA for devices compliant with the original PC AT bus specification, PCI/ISA PnP for devices compliant with the plug and play standard whether designed for PCI or ISA bus architecture

The choice: Enabled, Disabled.

Assign IRQ For VGA

To enable VGA IRQ assignation by selecting enabled.

The choice: Enabled, Disabled.

INT Pin 1 Assignment

Devices (S) using this INT: Display Cntrlr - Bus 0 Dev 2 Func 0 USB 1.0/1.1 UHCI Cntrlr - Bus 0 Dev29 Func 0.

The choice: Auto, 3, 4, 5, 7, 9, 10, 11, 12, 14, 15.

INT Pin 2 Assignment

Devices (S) using this INT: Multimedia Device – Bus 0 Dev 31 Func 5 Simple COMM. Cntrlr – Bus 0 Dev 31 Func 6 SMBus Cntrlr – Bus 0 Dev 31 Func 3.

The choice: Auto, 3, 4, 5, 7, 9, 10, 11, 12, 14, 15.

INT Pin 3/Pin 6/Pin 7 Assignment

Devices (S) using this INT: USB 1.0/1.1 UHCI Cntrlr – Bus 0 Dev 29 Func 2.

The choice: Auto, 3, 4, 5, 7, 9, 10, 11, 12, 14, 15.

INT Pin 4 Assignment

Devices (S) using this INT: USB 1.0/1.1 UHCI Cntrlr – Bus 0 Dev 29 Func 1.

The choice: Auto, 3, 4, 5, 7, 9, 10, 11, 12, 14, 15.

INT Pin 5 Assignment

Devices (S) using this INT: Network Cntrlr – Bus 1 Dev 8 Func 0.

The choice: Auto, 3, 4, 5, 7, 9, 10, 11, 12, 14, 15.

INT Pin 6 Assignment/ INT Pin 7 Assignment

Device(s) using this INT.

The choice: Auto, 3, 4, 5, 7, 9, 10, 11, 12, 14, 15.

INT Pin 8 Assignment

Devices (S) using this INT: USB 2.0 EHCI Cntrlr – Bus 0 Dev 29 Func 7.

The choice: Auto, 3, 4, 5, 7, 9, 10, 11, 12, 14, 15.

4.10 PC Health Status

Phoenix- AwardBIOS CMOS Setup Utility
PC Health Status

CPU Warning Temperature [Disabled] Current System Temperature Current CPU Temperature Current CPU FAN Speed Current System FAN Speed Current Power FAN Speed IN0 (V) IN2 (V) +5 V +12 V -12 V UBAT(V) 5VSB(V) CPU Throttle Temperature [Disabled]	Item Help
	Menu Level ►
↑↓→←: Move Enter: Select +/-/PU/PD: Value F10: Save ESC: Exit F1: General Help F5: Previous Values F6: Fail-Safe Defaults F7: Optimized Defaults	

CPU Warning Temperature

This item allows you to set a temperature above which the system will start the beeping warning. Default setting is Disabled. This function will only with “ACPI” power management and “S3 (STR)” suspend type.

The choices : Disabled, 50°C /122°F, 53°C /127°F, 56°C /133°F, 60°C /140°F, 63°C /145°F, 66°C /151°F, 70°C /158°F.

CPU Throttle Temperature

This item allows you to set a temperature above which the system will operate in lower speed immediately. Default setting is Disabled. This function will only with “ACPI” power management and “S3 (STR)” suspend type.

The choice: Disabled, 60°C /140°F, 65°C /149°F, 70°C /158°F, 75°C /167°F .

4.11 Frequency/Voltage Control

Phoenix- AwardBIOS CMOS Setup Utility
PC Health Status

CPU Clock Ratio	[19 %]	Item Help
Auto Detect PCI Clk	[Enabled]	Menu Level ▶
Spread Spectrum	[Disabled]	
↑↓→←: Move Enter: Select +/-/PU/PD: Value F10: Save ESC: Exit F1: General Help F5: Previous Values F6: Fail-Safe Defaults F7: Optimized Defaults		

Auto Detect PCI Clk

The choice: Enabled, Disabled.

Spread Spectrum

This item allows you to enable/disable the spread spectrum modulate

The choice: Enabled, Disabled.

4.12 Default Menu

Selecting “Defaults” from the main menu shows you two options which are described below

Load Fail-Safe Defaults

When you press <Enter> on this item you get a confirmation dialog box with a message similar to:

Load Fail-Safe Defaults (Y/N)? **N**

Pressing ‘Y’ loads the BIOS default values for the most stable, minimal-performance system operations.

Load Optimized Defaults

When you press <Enter> on this item you get a confirmation dialog box with a message similar to:

Load Optimized Defaults (Y/N)? **N**

Pressing ‘Y’ loads the default values that are factory settings for optimal performance system operations.

4.13 Supervisor/User Password Setting

You can set either supervisor or user password, or both of them. The differences between are:

Set Supervisor Password : can enter and change the options of the setup menus.

Set User Password : just can only enter but do not have the right to change the options of the setup menus. When you select this function, the following message will appear at the center of the screen to assist you in creating a password.

ENTER PASSWORD

Type the password, up to eight characters in length, and press <Enter>. The password typed now will clear any previously entered password from CMOS memory. You will be asked to confirm the password. Type the password again and press <Enter>. You may also press <Esc> to abort the selection and not enter a password.

To disable a password, just press <Enter> when you are prompted to enter the password. A message will confirm the password will be disabled. Once the password is disabled, the system will boot and you can enter Setup freely.

PASSWORD DISABLED

When a password has been enabled, you will be prompted to enter it every time you try to enter Setup. This prevents an unauthorized person from changing any part of your system configuration.

Additionally, when a password is enabled, you can also require the BIOS to request a password every time your system is rebooted. This would prevent unauthorized use of your computer.

You determine when the password is required within the BIOS Features Setup Menu and its Security option (see Section 3). If the Security option is set to "System", the password will be required both at boot and at entry to Setup. If set to "Setup", prompting only occurs when trying to enter Setup.

4.14 Exiting Selection

Save & Exit Setup

Pressing <Enter> on this item asks for confirmation:

Save to CMOS and EXIT (Y/N)? Y

Pressing “Y” stores the selections made in the menus in CMOS – a special section of memory that stays on after you turn your system off. The next time you boot your computer, the BIOS configures your system according to the Setup selections stored in CMOS. After saving the values the system is restarted again.

Exit Without Saving

Pressing <Enter> on this item asks for confirmation:

Quit Without Saving (Y/N)? N

This allows you to exit Setup without storing in CMOS any change. The previous selections remain in effect. This exits the Setup utility and restarts your computer.

Chapter 5 Troubleshooting

This chapter provides you a few useful tips to quickly get your 3307421 running with no failure. As basic hardware installation has been addressed in Chapter 3, this chapter will basically focus on system integration issues, in terms of backplane setup, BIOS setting, and OS diagnostics.

5.1 Backplane Setup

Backplane

3307421 is a full-sized SBC, and therefore is only able to run on PICMG PCI/ISA Backplane.

P4 Power connector

3307421 requires power drawing from at least two connectors. The CPU supplementary power connector (J26) should be connected at all time for this P4 system to run properly. At its standalone mode, the single board computer will connect no peripheral device cards. 4-pin connector for CPU (J26) and the 4pin connector (J31) must be connected. If the system's main power comes from a backplane, the CPU supplementary power connector (J26) should still be connected.

ATX power

3307421 is designed to also support ATX mode. Please refer to the following instruction to apply ATX power on your 3307421 and backplane.

Step1: Remove the jumper on pin3 and pin4 of ATX P/S CONTROL CONNECTOR (4-pin) connector (see the Figure below).

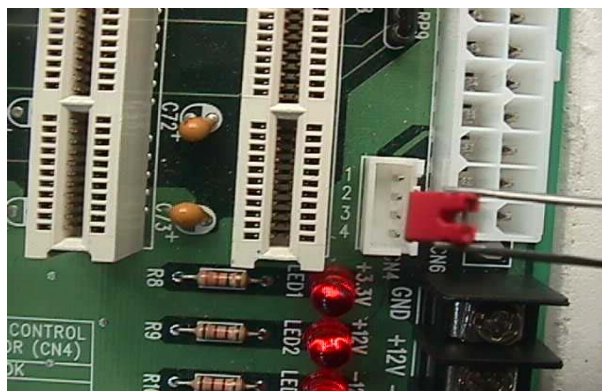

Step2: Connect 20-pin power cable of the ATX POWER with ATX POWER CONNECTOR (20-pin) on the backplane.

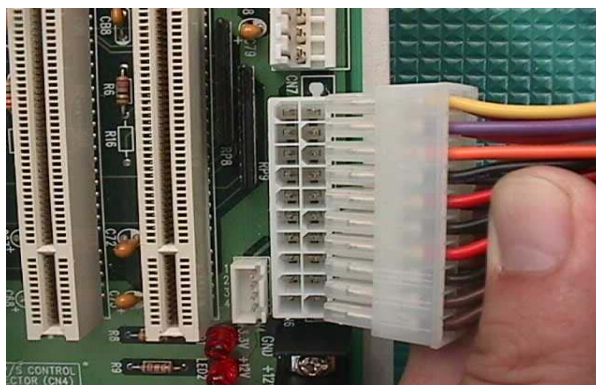

Step3: Use a 4-pin power cable to connect the ATX P/S CONTROL CONNECTOR (4-pin) connector on the backplane.

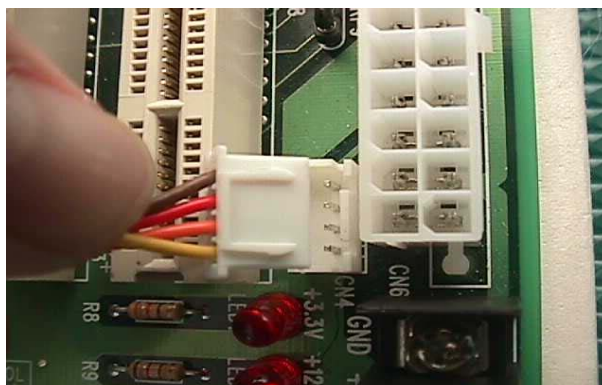

Step4: Please find the J29 4-pin ATX Power Control Connector on the right part of 3307421 in white color. You will also see a mark with "J29" on the lower side of J29 header. Connect the 4-pin ATX power control cable with this J29 header.

Step5: Please adjust the AT/ATX jumper on JP3 to short 3-5,4-6 pins, then it can support ATX power scheme.



Step6: Connect TOGGLE SWITCH with J32 connector on 3307421.

Step7: The figure below is the TOGGLE SWITCH, which is used to switch the ATX Power on/off for SBC. Usually the TOGGLE SWITCH is located on the chassis front panel. Pressing the switch button once will turn power on, and press again to turn it off.

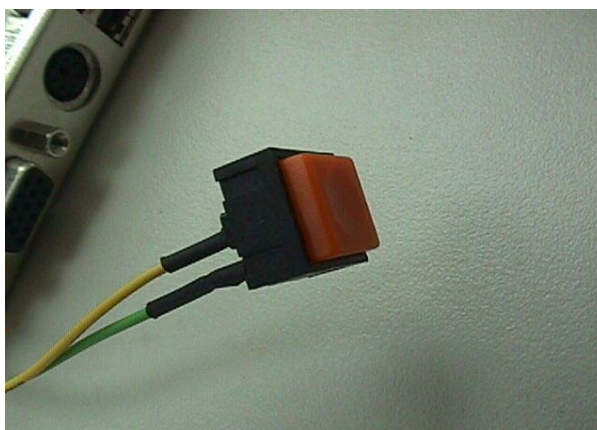

Q: In addition to the above description, is there anything to do to finish up an ATX system?

A: Yes. 3307421 needs to be configured to support ATX function for the above cabling. Please move jumper JP3 to 3-5 short and 4-6 short (support ATX function).

Q: How can I build up an AT system using ATX power supply

A: Do not forget to move JP3 of 3307421 back to 1-3 short and 2-4 short (support AT function).

If the ATX power supply has a switch, such as ORION-300ATX, do not remove the jumper of backplane connector in step 1, and use the power supply switch as the system power on switch.

In all cases, users may apply a 2-pin AT (on/off) switch over pin-3 and pin-4 of the backplane connector in step 1. However, power supply switch needs to be moved to “on”, if there is one.

5.2 Onboard Hardware Installation

Q: How do I connect my keyboard and mouse ?

A: Users may always adopt PS/2 keyboard and mouse over the PS/2 interface (through Y-cable), J13 on 3307421.

However, it is also fine to adopt a standard keyboard over the standard keyboard connector on backplane, if provided. In this way, users need to adopt a 5-pin keyboard connection cable to line-up, external keyboard interface, J14 on 3307421 with the 5-pin keyboard connector on backplane.

Q: OK. I have finished up hardware installation, but I got nothing when I power on the system. Why?

A: There are thousands of different reasons to get this power on failure.

1. Check 3307421 jumper, JP3. For AT power supply or ATX power supply used for AT system, JP3 needs to be at 1-3 and 2-4. Otherwise, it needs to be at 3-5 and 4-6. Incorrect power setting will not allow you to power on the system.
2. Double check if every connector is attached with the correct cable.
3. If you have changed processor with different system clock, please move JP1 (CMOS clear Jumper) to 2-3, power on the system to clear CMOS (move on/off switch from off to on for AT mode, or toggle the switch for ATX mode), power off the system, move JP1 back to 1-2, and power on again.

Q: I power on the system, but the CPU speed is not correct. Why?

A: This applies to Engineering Sample processor ONLY. If you have ever loaded the BIOS optimal default, thank you for doing so. However, this will force the BIOS to pick up the default CPU core/bus ratio as well. It needs to be emphasized again that 3307421 does not have switch or jumper to configure CPU core/bus ratio. This is done through BIOS automatically. Please check in the “Frequency/Voltage Control” section of Chapter 4 (4-11) to adjust this core/bus ratio (only available when you plug in the engineering sample processor from Intel). System default setting is automatically setting when you plug in commercial processors from Intel and you will not see the CPU Clock Ratio item in the BIOS setting screen.

Q: I connect two IDE devices over one IDE flat cable, but the system either does not start, or just hangs from time to time. Why ?

A: Make sure that you have configured the two IDE devices as a master and a slave, respectively.

Q: I am using an ATA-66 (or 100) hard drive, how can I know that ATA-66 function is started??

A: You need to use the 80-pin ATA-66 IDE flat cable to have this function ready. During POST, you can see ATA-66 (or 100) message while hard drive is being detected. Besides, after Microsoft series OS installation successfully, you must install ATA-66/100 driver, then the function can be active.

5.3 BIOS Setting

It is assumed that users have correctly adopted modules and connected all the device cables required before turning on AT power. CPU, CPU fan, CPU fan power cable, 184-pin DDR SDRAM, keyboard, mouse, floppy drive, IDE hard disk, printer, VGA connector, device power cables, ATX accessories or 12V 4-pin power cable are good examples that deserve attention. With no assurance of properly and correctly accommodating these modules and devices, it is very possible to encounter system failures that result in malfunction of any device.

To make sure that you have a successful start with 3307421, it is recommended, when going with the boot-up sequence, to hit "DEL" key and enter the BIOS setup menu to tune up a stable BIOS configuration so that you can wake up your system far well.

Loading the default optimal setting

When prompted with the main setup menu, please scroll down to "Load Optimal Defaults", press "Enter" and "Y" to load in default optimal BIOS setup. This will force your BIOS setting back to the initial factory configuration. It is recommended to do this so you can be sure the system is running with the BIOS setting that has highly endorsed. As a matter of fact, users can load the default BIOS setting any time when system appears to be unstable in boot up sequence.

Auto Detect Hard Disks

In the BIOS => Standard CMOS setup menu, pick up any one from Primary/Secondary Master/Slave IDE ports, and press "Enter". Setup the selected IDE port and its access mode to "Auto". This will force system to automatically pick up the IDE devices that are being connected each time system boots up.

Improper disable operation

There are too many occasions where users disable a certain device/feature in one application through BIOS setting. These variables may not be set back to the original values when needed. These devices/features will certainly fail to be detected.

When the above conditions happen, it is strongly recommended to check the BIOS settings. Make sure certain items are set as they should be. These include the floppy drive, COM1/COM2 ports, parallel port, USB ports, external cache, on-board VGA and Ethernet.

It is also very common that users would like to disable a certain device/port to release IRQ resource. A few good examples are

- disable COM1 serial port to release IRQ #4
- disable COM2 serial port to release IRQ #3
- disable parallel port to release IRQ #7

disable PS/2 mouse to release IRQ #12,
 ..., etc.

A quick review of the basic IRQ mapping is given below for your reference.

IRQ#	Description
IRQ #0	System Counter
IRQ #1	Keyboard
IRQ #2	Programmed Controller
IRQ #3	COM2
IRQ #4	COM1
IRQ #5	Nothing
IRQ #6	Floppy Disk Controller
IRQ #7	Printer Port (Parallel Port)
IRQ #8	CMOS Clock
IRQ #9	Nothing
IRQ #10	USB interface
IRQ #11	Nothing
IRQ #12	PS/2 mouse
IRQ #13	Data Processor
IRQ #14	Primary IDE Controller
IRQ #15	Secondary IDE Controller

It is then very easy to find out which IRQ resource is ready for additional peripherals. If IRQ resource is not enough, please disable some devices listed above to release further IRQ numbers.

5.4 OS Diagnostics

What will be presented here is a brief guide to properly house-in the driver for any Microsoft Windows-95/98/NT device. For other operating systems, please refer to OS manual/guidebook.

Booting

Users may find quite a lot of Windows-95/98 hang during loading sequence. Windows logo stays with no progress, or simply no display is given. Please restart your system and hit "F5" when loading the Windows system and enter "Safe mode". Users will always be allowed to enter "Safe mode" with success to remove devices that are not properly running or installed. Please proceed to do so and restart your Windows. Devices with removed drivers will be automatically detected again. The drivers will be loaded automatically, if drivers have been included in the system database, else you will be asked to provide driver source for installation.

For Windows-NT 4.0 users, it is always not recommended to change your hardware configuration after your first installation. However, if such a change is needed, please note that sometimes Windows-NT 4.0 will stop loading and prompt you with a whole page of error messages. Please note that reinstallation of this NT hard disk is inevitable. You have to backup your data stored in this hard disk because it is almost impossible to switch back this system unless booting up with another hard disk. If this NT hard disk is installed with FAT16 disk format, please boot up your system with any Windows OS. You will be able to see this NT hard disk and retrieve any data you are interested in. However, if this NT hard disk is installed with NTFS disk format, there is only OS on an NTFS partition that will allow you to retrieve this NT hard disk again.

Display setup

By default, any Windows OS starts with 640 x 480 with 16 colors display. The display driver provided in 3307421 product CDROM can be installed into operating system to maximize the VGA performance. If you are using a monitor that Microsoft® Windows cannot identify, you will also need to set in the display from the setup menu, a system monitor to correctly retrieve display output. For Windows-NT 4.0 users, 3307421 provides AGP on-board display feature, Service Pack 3.0 or above is required to activate this display feature.

Network setup

Windows-95/98 users.

1. Please apply a PCI network card over PCI slot, or simply use the on-board Fast Ethernet device.
2. Start Windows-95/98 and let Window-95/98 automatically detect your network adapter.
3. Provide the driver and complete installation.
4. Restart your windows system is required.
5. After you come back to windows, please go to Control Panel -> System -> Device Manager and see if your network adapter has been properly installed. A warning sign will be prompted if the network adaptor is not properly installed.
6. Please remove this network device from system setup menu and restart windows to re-detect your network adapter again.
7. After you are sure that hardware installation is completed, please go to Control Panel -> Network to set up your networking configuration. This includes DNS, IP, and Gateway. Appropriate protocols are required to carry your networking activities. Please refer to your system administrator for additional assistance.

Windows-NT 4.0 users.

1. Please install your network adapter manually in Control Panel -> Network -> Adapter. Drivers are required at this stage.
2. Proceed "Binding" after you load in the driver.
3. Change to Protocol label and load in the protocols that you are interested (generally, TCP/IP). Configuring IP, gateway and DNS is required for TCP/IP protocol.
4. Proceed again "Binding" after you complete the protocol loading.
5. Restart your system.
6. There is also situation that the installed network adapter is not working anymore for you, or old network driver stays in the system after you change your network card. Please remove all the network adapters and protocols from network setup menu and redo the loading of driver and protocols again.
7. Network setup within Windows-NT 4.0 is not as easy as within Windows-95/98. Special familiarity and care are required for a successful installation.

Any advice or comments about our products and service, or anything we can help you with please don't hesitate to contact with us. We will do our best to support your products, projects and business.



Address: Global American, Inc.
17 Hampshire Drive
Hudson, NH 03051

Telephone: Toll Free U.S. Only (800) 833-8999
(603) 886-3900

FAX: (603) 886-4545

Website: <http://www.globalamericaninc.com>

Support: Technical Support at Global American
