



integration with integrity

User's Manual

Single Board Computer 3307555

Version 1.0,

Full Size Socket 370 Pentium III / Celeron CPU Card
with 66/100 MHzFSB,

Four DIMM Sockets for up to 1 GB SDRAM,

Flat Panel / CRTSVGA USB 1.0,

and Disk On Chip Interfaces

Copyrights

This manual is copyrighted and all rights are reserved. It does not allow any non authorization in copied, photocopied, translated or reproduced to any electronic or machine readable form in whole or in part without prior written consent from the manufacturer.

In general, the manufacturer will not be liable for any direct, indirect, special, incidental or consequential damages arising from the use of inability to use the product or documentation, even if advised of the possibility of such damages. The manufacturer keeps the rights in the subject to change the contents of this manual without prior notices in order to improve the function design, performance, quality and reliability. The author assumes no responsibility for any errors or omissions, which may appear in this manual, nor does it make a commitment to update the information contained herein.

Trademarks

Intel is a registered trademark of Intel Corporation.

Award is a registered trademark of Award Software, Inc.

All other trademarks, products and or product's name mentioned herein are mentioned for identification purposes only, and may be trademarks and/or registered trademarks of their respective companies or owners.

Table of Contents

How to Use This Manual

Chapter 1 Introduction

1.1 Check List	1 – 2
1.2 Product Specifications	1 – 3
1.3 System Architecture	1 – 6

Chapter 2 Hardware Configuration Setting

2.1 Jumpers	2 – 1
2.2 Connectors	2 – 5

Chapter 3 System Installation

3.1 Socket 370 Celeron Processor	3 – 1
3.2 Main Memory	3 – 1
3.3 M-system Flash Disk	3 – 2
3.4 Installing the Single Board Computer	3 – 2
3.4.1 CHIPS 69000 Graphics Controller	3 – 3
3.4.2 LCD Panel Interface Kit	3 – 4
3.4.3 Driver Support	3 – 5
3.5 Watch Dog Timer Programming	3 – 5

Chapter 4 BIOS Setup Information

4.1 Entering Setup	4 – 1
4.2 Main Menu	4 – 2
4.3 CMOS Setup Reference Table.....	4 – 3
4.4 Standard CMOS Setup Menu	4 – 6
4.5 Advanced CMOS Setup Menu	4 – 6
4.6 Advanced Chipset Setup Menu	4 – 8
4.7 Power Management Setup Menu	4 – 11
4.8 PCI/Plug and Play Setup Menu	4 – 14
4.9 Peripheral Setup Menu	4 – 16
4.10 Hardware Monitor Setup Menu	4 – 18
4.11 BIOS POST Check Point List	4 – 18
4.12 Flash BIOS Utility	4 – 24

Chapter 5 Troubleshooting

5.1 Backplane setup	5 – 1
5.2 BIOS setting.....	5 – 4
5.3 OS diagnostics	5 – 6

How to Use This Manual

The manual describes how to configure your 3307555 system to meet various operating requirements. It is divided into five chapters, with each chapter addressing a basic concept and operation of Single Board Computer.

Chapter 1: Introduction. presents what you have in the inside of box and give you an overview of the product specifications and basic system architecture for this model of single board computer.

Chapter 2: Hardware Configuration Setting. shows the definitions and locations of Jumpers and Connectors that you can easily configure your system.

Chapter 3: System Installation. describes how to properly mount the CPU and main memory, M-system Flash disk, or optional flat panel display interface module to get a safe installation and give you a programming guide of Watch Dog Timer function. Besides, it will introduce and show you the driver installation procedure about Graphics Controller.

Chapter 4: BIOS Setup Information. specifies the meaning of each setup parameters and how to get advanced BIOS performance and update new BIOS. In addition, POST checkpoint list will give you a guide of trouble-shooting.

Chapter 5: Troubleshooting. gives you a few reminding hints in building up a valid and working system with 3307555, in terms of hardware and software perspective. Issues addressed are based on the customer application history collected throughout the years, and are presented as the most frequently encountered problems.

CHAPTER 1

Introduction

The 3307555 all-in-one full-sized single board computer is designed to fit a high performance Celeron based processor and compatible for high-end computer system application with PCI/ISA bus architecture. It is made to meet today's demanding pace, and keep complete compatibility with hardware and software designed for the IBM PC/AT. The on-board PCI bus supports one PCI device VGA with optional panel display. It's beneficial to build up a high performance and high data availability system for VARs, or system integrators.

This single board computer can run with Intel Pentium-II/III (Celeron or Coppermine) processor, and support DIMM up to 1GB DRAM. The enhanced on-board PCI IDE interface can support 4 drives up to PIO mode 4 timing and Ultra DMA/33 synchronous mode feature. The on-board Super I/O Chipset integrates floppy controller, two serial ports, one FIR (Fast Infrared) port and one parallel port. Two high performance 16C550-compatible UARTs provide 16-byte send/receive FIFOs, and the multi-mode parallel port supports SPP/EPP/ECP function. Besides, two Universal Serial Bus ports provide high-speed data communication between peripherals and PC.

The PICMG standard makes the 3307555 works with the legacy ISA, ISA/PCI or multi-slots PCI-bus backplane. The on-board 32-pin DIP socket supports M-systems Disk On Chip Flash disk up to 144MB, and one PC/104 interface provides flexible embedded platform. Built-in Watch-dog Timer function monitors your system status. Two 6-pin Mini-DIN connectors are provided to connect PS/2 mouse and keyboard. The on-board Flash ROM is used to make the BIOS update easier. A standard P8 power connector is reserved to directly get more power for embedded application, and the additional 5-pin shrouded connector is reserved for connecting keyboard interface on the backplane. The high precision Real Time Clock/calendar is built to support Y2K for accurate scheduling and storing configuration information. One 4-pin header is designed to support ATX power function. A feature of CPU overheat protection will give user more security and stability. All of these features make 3307555 excellent in stand-alone applications.

1-1 Check List

The 3307555 package includes the following basic items accompany with this manual.

- One 3307555 single board computer
- One Printer port cable kit
- One 10-pin cable kit for VGA port
- One FDC cable
- One IDE cable
- One 5-pin to 5-pin keyboard cable for backplane connection
- One 4-pin ATX power control cable for backplane connection
- One component kit includes PC/104 extension connector
- One CD-Title 3307555 to support CHIPS B69000 VGA display driver

1-2 Product Specifications

- **Main processor**
Intel Celeron processor and Intel Coppermine processor
CPU bus clock : 66/100 MHz
CPU core/bus clock ratio : x2 to x8
- **BIOS**
AMI system BIOS with 256KB Flash ROM to support DMI, PnP, APM, and ACPI (option)
- **Main Memory**
Four 168-pin DIMM sockets, supporting 3.3V SDRAM with parity/ECC function up to 1GB
- **L2 Cache Memory**
128KB/256KB PBSRAM built in CPU module
- **Chipset**
Intel 440BX AGPset
- **Bus Interface**
Follow PICMG standard (32-bit PCI and 16-bit ISA bus)
Fully complies with PCI bus specification V2.1
- **PCI IDE Interface**
Support two enhanced IDE ports up to four HDD devices with PIO mode 4 and Ultra DMA/33 mode 2 timing transfer
- **Floppy Drive Interface**
Support one FDD port up to two floppy drives and 5-1/4"(360K, 1.2MB), 3-1/2" (720K, 1.2MB, 1.44MB, 2.88MB) diskette format and 3-mode FDD (option)
- **Serial Ports**
Support two high-speed 16C550 compatible UARTs with 16-byte T/R FIFOs
- **IR Interface**
Support one 6-pin header for serial Fast/Standard Infrared wireless communication
- **Parallel Port**
Support one parallel port with SPP, Bi-direction, and EPP/ECP mode

- **USB Interface**
Support two USB (Universal Serial Bus) ports for high speed I/O peripheral devices

- **PS/2 Mouse and Keyboard Interface**
Support two 6-pin Mini-DIN connectors and one 5-pin shrouded connector for PS/2 mouse, keyboard and backplane connection

- **ATX Power Control Interface**
One 4-pin header to support ATX power control with Modem Ring-On and Wake-On-LAN function

- **Auxiliary I/O Interfaces**
System reset switch, external speaker, Keyboard lock and HDD LED interface

- **Real Time Clock/Calendar**
Support Y2K Real Time Clock/calendar with battery backup for 10-year data retention

- **Watchdog Timer**
0.5,1,2,4,8,16,32,64 sec. time-out intervals by jumper setting or 255 intervals from 0.5 min. to 254.5 min. by software programming

- **DiskOnChip Feature**
Reserved one 32-pin socket for M-systems Flash Disk up to 144MB

- **On-board VGA and Flat Panel Interface**
Adopt CHIPS 69000 HiQVideo Accelerator with integrated memory 2MB to provide high performance graphics and panel display capabilities

- **CPU Overheat Protection**
Auto speed down when CPU overheats (OS independent & Driverless)

- **Power Good**
On-board power good generator with reset time, 300ms < 500ms

- **System Monitoring Feature**
Monitor CPU current temperature.

- **Physical and Environmental Requirements**

Outline Dimension (L X W) : 338.5mm (13.36") X 121.5mm (4.78")

Board Weight : 0.92 lb. (0.42kg)

PCB layout : 6 layer

Power Requirements : +5V @6A (typ.), +12V @140mA, -12V @30mA

Operating Temperature : 0°C ~ 60°C (32°F ~ 140°F)

Storage Temperature : -20°C ~ 80°C

Relative Humidity : 5% ~ 95%, non-condensing

1-3 System Architecture

The following illustration of block diagram will show you how 3307555 gives you a highly integrated system solution. The most up-to-date system architecture of 3307555, includes two main VLSI chips , 82443BX Host Bridge and 82371EB PIIX4E, to support Celeron processor, SDRAM with ECC, PCI bus interface, ACPI compliant power management (option), USB port, SMBus communication, and Ultra DMA/33 IDE Bus Master. The on-board super I/O chip , W83977ATF, will support PS/2 Keyboard/Mouse, two UARTs, FDC, Parallel and Infrared interface. Besides, an on-board PCI device VGA/panel display will provide user more flexibility and reliability in a highly integrated application.

3307555 built-in Socket 370 to support Intel Celeron processor Plastic Pin Grid Array (**PPGA**) package and Pentium-III FC-PGA Coppermine processor for high performance and cost-effective application. The Intel Celeron processor is the next addition to the P6 micro architecture processor product lines. The Intel Celeron processor, like the Intel Pentium Pro and Intel Pentium II processor, features a Dynamic Execution microarchitecture and also executes MMX technology instructions for enhanced media and communication performance.

The North Bridge 82443BX provides a completely integrated solution for the system controller and data path components in a Celeron processor system. It provides a 64-bit GTL+ based host bus interface, optimized 64-bit DRAM interface with ECC to support two 3.3V DIMMs at the maximum bus frequency of 100 MHz, and 32-bit PCI bus interface to support on-board PCI device.

The South Bridge, 82371EB PCI ISA IDE Xcelerator (PIIX4E), provides a highly integrated multifunction PCI-to-ISA bridge solution for the best industry application. It supports 1-channel dedicated Ultra DMA-33 IDE master interface, full Plug-and-Play compatibility, and Advanced Programmable Interrupt Controller (**APIC**) interface on 3307555. It also supports 2 Universal Serial Bus (**USB port**) and PCI 2.1 Compliance operation. In addition, it also provides XD-bus via buffer logic control to support BIOS read/write access and external Real-time Clock (**RTC**) to maintain date and time of a system.

The Super I/O chip W83977ATF, which integrates two high-speed serial ports, one parallel port, FIR/SIR interface, 8042 keyboard controller with PS/2 mouse ports and FDD interface. This parallel port supports one PC-compatible printer port (**SPP**), Enhanced Parallel Port (**EPP**) and Extended Capabilities Port (**ECP**).

A standard 16-bit ISA bus slot and PC/104 bus interface is applied for all of slower I/O operations. In 3307555, it contains Watch-dog Timer (**WDT**) enabled by jumper setting and triggered by software, and DiskOnChip (**DOC**) for M-systems Flash disk. Besides, an advanced feature is used on 3307555 to support detection of CPU temperature. The CPU operation will be automatically forced to speed down when overheating happens.

The on-board PCI device, graphics display port, powered by CHIPS 69000 graphics accelerator to support one VGA display and panel interface port.

All of detail operating relations are shown in Figure 1-1 3307555 System Block Diagram.

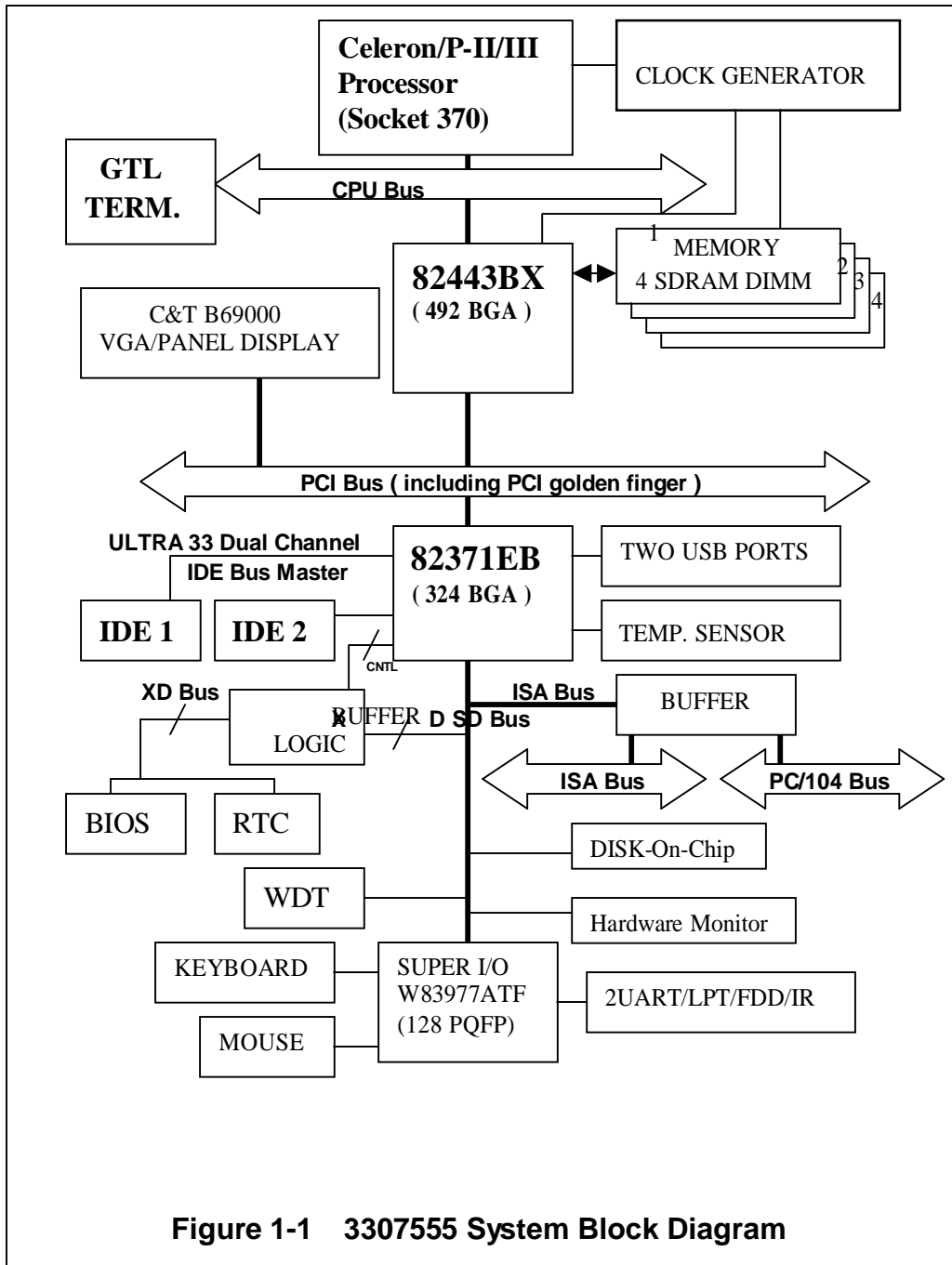

CHAPTER 2

Hardware Configuration Setting

This chapter gives the definitions and shows the positions of jumpers, headers and connectors. All of the configuration jumpers on 3307555 are in the proper position. The default settings set by factory are marked with a star (*).

2-1 Jumpers

In general, jumpers on the single board computer are used to select options for certain features. Some of the jumpers are designed to be user-configurable, allowing for system enhancement. The others are for testing purpose only and should not be altered. To select any option, cover the jumper cap over (close) or remove (open) it from the jumper pins according to the following instructions. (Refer to Figure 2-1 for jumper positions)

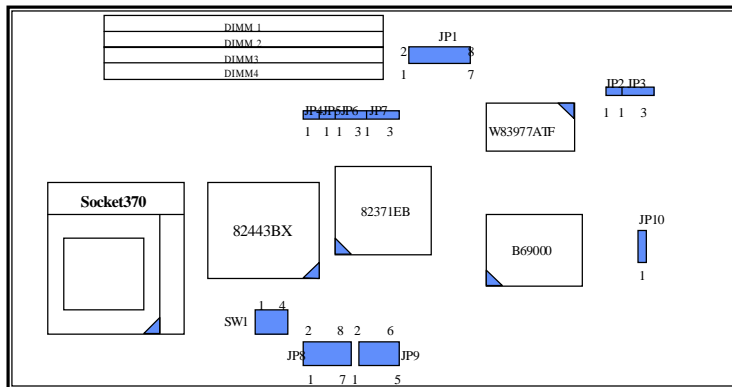

Figure 2-1 3307555 Jumper Locations

CPU Jumper Setting Table (SW1)

SW1 DIP switch settings for CPU core/bus ratio

SW-1	SW-2	SW-3	SW-4	CORE/BUS RATIO
OFF	OFF	ON	OFF	1.5x
OFF	OFF	OFF	OFF	2.0x
ON	ON	ON	ON	2.0x
ON	OFF	ON	ON	2.5x
ON	ON	OFF	ON	3.0x
ON	OFF	OFF	ON	3.5x
ON	ON	ON	OFF	4.0x
ON	OFF	ON	OFF	4.5x
ON	ON	OFF	OFF	5.0x
ON	OFF	OFF	OFF	5.5x *
OFF	ON	ON	ON	6.0x
OFF	OFF	ON	ON	6.5x
OFF	ON	OFF	ON	7.0x
OFF	OFF	OFF	ON	7.5x
OFF	ON	ON	OFF	8.0x
OFF	ON	OFF	OFF	Reserved

NOTE : For system stability, do not arbitrarily set CPU to run over speed unless you can handle BIOS parameters.

Disk-On-Chip Jumper Setting (JP8)

1 - 2	3 - 4	5 - 6	7 - 8	Memory Address Window
Short	NC	NC	NC	D0000 - D1FFF !
NC	Short	NC	NC	D2000 - D3FFF
NC	NC	Short	NC	D4000 - D5FFF
NC	NC	NC	Short	D6000 - D7FFF

Watch-Dog Timer Jumper Setting (JP4, JP5, JP6, JP7, JP9)

JP4 NC : Enabled WDT function
Short : Disabled WDT function *

JP5 NC : Allocate I/O port 0533H/0033H for programming of H/W WDT *
Short : Allocate I/O port 0543H/0343H for programming of H/W WDT

JP6 1 – 2 : Connect WDT output to system reset *
 2 – 3 : Connect WDT output to NMI

JP9 WDT Time-out Interval (Twd) settings

5-6	3-4	1-2	Time-out Interval (Twd)
Short	Short	Short	0.5 sec.
Short	Short	NC	1 sec. *
Short	NC	Short	2 sec.
Short	NC	NC	4 sec.
NC	Short	Short	8 sec.
NC	Short	NC	16 sec.
NC	NC	Short	32 sec.
NC	NC	NC	64 sec.

JP7 WDT Time-out sources :

1 – 2 : initiated from hardware WDT by setting JP9 *
 2 – 3 : initiated from software WDT by programming super I/O chipset
 W83977ATF

RTC CMOS Clear Jumper Setting (JP2)

JP2 NC : Normal operation *
 Short : Clear CMOS contents

NOTE : This CMOS clearing operation can be done under system power on if CMOS RAM CLEAR FUNCTION does not exist in Advanced Chipset Setup. It also can be done under system power on or off. However please make sure that the CMOS RAM clear option has been enabled in Advanced Chipset Setup before CMOS clearing happens.

AT/ATX Power Supply Selection (JP3)

JP3 1 – 2 : Select ATX power supply
 2 – 3 : Select AT power supply *

Optional LCD Panel Type Jumper Setting (JP1)**JP1 : Flat Panel Type**

Type	7 - 8	5 - 6	3 - 4	1 - 2	Flat Panel Type
1	Short	Short	Short	Short	1024x768 Dual Scan STN Color Panel !reserved
2	Short	Short	Short	NC	1280x1024 TFT Color Panel !reserved
3	Short	Short	NC	Short	640x480 Dual Scan STN Color Panel !reserved
4	Short	Short	NC	NC	800x600 Dual Scan STN Color Panel !reserved
5	Short	NC	Short	Short	640x480 Sharp TFT Color Panel !reserved
6	Short	NC	Short	NC	640x480 18-bit TFT Color Panel
7	Short	NC	NC	Short	1024x768 TFT Color Panel
8	Short	NC	NC	NC	800x600 TFT Color Panel
9	NC	Short	Short	Short	800x600 TFT Color Panel (L. BIOS) !reserved
10	NC	Short	Short	NC	800x600 TFT Color Panel (L. BIOS)
11	NC	Short	NC	Short	800x600 Dual Scan STN Color Panel (L. BIOS) !reserved
12	NC	Short	NC	NC	800x600 Dual Scan STN Color Panel (L. BIOS) !reserved
13	NC	NC	Short	Short	1024x768 TFT Color Panel (L. BIOS) !reserved
14	NC	NC	Short	NC	1280x1024 Dual Scan STN Color Panel (L. BIOS)!reserved
15	NC	NC	NC	Short	1024x600 Dual Scan STN Color Panel (L. BIOS) !reserved
16	NC	NC	NC	NC	1024x600 TFT Color Panel (Large BIOS)

NOTE : This jumper JP1 is only for reference. It will be ignored by BIOS panel setting in Advanced CMOS Setup. Normally, it is not set by factory default.

Onboard devices (VGA) enable/disable jumper (JP10)

JP10 1 - 2 : Normal operation *
2 - 3 : Disable onboard VGA

2-2 Connectors

I/O peripheral devices and Flash disk will be connected to these interface connectors or DOC socket located on this single board computer.

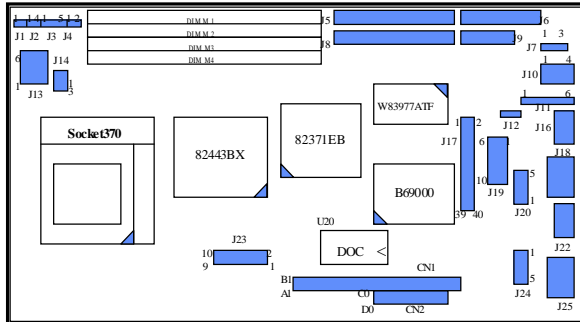

Figure 2-2 3307555 Connector Locations

CONNECTOR	FUNCTION	REMARK
J1	System reset	
J2	External speaker interface	
J3	Keyboard lock and power indicator	
J4	IDE active LED interface	
J5	IDE1 (Primary) interface	
J6	Floppy connector	
J7	Wake-On-LAN (WOL) 3-pin header	Connect to LAN card
J8	IDE2 (Secondary) interface	
J9	Parallel port connector	
J10	ATX power control interface	Connect to Backplane
J11	IrDA (infrared) port	Support FIR/SIR
J12	ATX power button interface	Connect to Chassis
J13	Standard P8 power connector	
J14	CPU cooling fan power connector	Support +12V
J16	COM1 serial port	DSUB-9
J17	Flat Panel display module interface	2x20 pin header
J18	PS/2 mouse connector	6-pin Mini-DIN
J19	VGA connector	2 x 5 shrouded header
J20	External PS/2 mouse connector	Connect mouse cable kit
J22	COM2 serial port	DSUB-9
J23	External USB interface	Support two ports
J24	External keyboard interface	Connect to backplane
J25	PS/2 keyboard connector	6-pin Mini-DIN

CONNECTOR	FUNCTION	REMARK
U20	On-board Flash disk (Disk On Chip)	32-pin DIP socket
CN1, CN2	PC/104-bus connector	32x2 and 20x2 socket

Pin Assignments of Connectors

Ÿ J1 : Reset Header

PIN No.	Signal Description
1	Reset
2	Ground

Ÿ J2 : External Speaker Header

PIN No.	Signal Description
1	Speaker signal
2	N/C
3	Ground
4	+5V

Ÿ J3 : Keyboard Lock Header

PIN No.	Signal Description
1	+5V (330 ohm pull-up for power LED)
2	N/C
3	Ground
4	Keyboard inhibit
5	Ground

Ÿ J4 : IDE1 Active LED Header

PIN No.	Signal Description
1	+5V (470 ohm pull-up for HDD LED)
2	HDD Active # (LED cathode terminal)

Ÿ J7 : Wake-On-LAN Interface

PIN No.	Signal Description
1	5V Stand-by Power
2	GND
3	LAN Wake-up Activating Signal

∩ J5/ J8 : IDE1/IDE2 Interface Connector

PIN No.	Signal Description	PIN No.	Signal Description
1	RESET#	2	Ground
3	Data 7	4	Data 8
5	Data 6	6	Data 9
7	Data 5	8	Data 10
9	Data 4	10	Data 11
11	Data 3	12	Data 12
13	Data 2	14	Data 13
15	Data 1	16	Data 14
17	Data 0	18	Data 15
19	Ground	20	N/C
21	DMA REQ	22	Ground
23	IOW#	24	Ground
25	IOR#	26	Ground
27	IOCHRDY	28	Pull-down
29	DMA ACK#	30	Ground
31	INT REQ	32	N/C
33	SA1	34	N/C
35	SA0	36	SA2
37	HDC CS0#	38	HDC CS1#
39	HDD Active#	40	Ground

∩ J9 : Parallel Port Connector

PIN No.	Signal Description	PIN No.	Signal Description
1	Strobe#	14	Auto Form Feed#
2	Data 0	15	Error#
3	Data 1	16	Initialization#
4	Data 2	17	Printer Select IN#
5	Data 3	18	Ground
6	Data 4	19	Ground
7	Data 5	20	Ground
8	Data 6	21	Ground
9	Data 7	22	Ground
10	Acknowledge#	23	Ground
11	Busy	24	Ground
12	Paper Empty	25	Ground
13	Printer Select	26	N/C

✧ J6 : FDC Interface Connector

PIN No.	Signal Description	PIN No.	Signal Description
1	Ground	2	Density Select
3	Ground	4	N/C
5	Ground	6	N/C
7	Ground	8	Index#
9	Ground	10	Motor ENA#
11	Ground	12	Drive Select B#
13	Ground	14	Drive Select A#
15	Ground	16	Motor ENB#
17	Ground	18	Direction#
19	Ground	20	Step#
21	Ground	22	Write Data#
23	Ground	24	Write Gate#
25	Ground	26	Track 0#
27	Ground	28	Write Protect#
29	Ground	30	Read Data#
31	Ground	32	Head Select#
33	Ground	34	Disk Change#

✧ J10 : ATX Power Control Connector

PIN No.	Signal Description
1	ATX Power Good Signal
2	ATX 5V Stand-by
3	ATX Power On Control
4	Ground

✧ J11 : Fast & Standard IrDA Header

PIN No.	Signal Description
1	VCC (+5V)
2	FIRRX
3	SIRRX
4	Ground
5	IRTX
6	N/C

✧ J12 : ATX Power Button Interface

PIN No.	Signal Description
1	Power Button Control Signal
2	Ground

Ÿ J13 : Standard P8 Power Connector

PIN No.	Signal Description
1	N/C
2	+5V
3	+12V
4	-12V
5	Ground
6	Ground

Ÿ J14 : CPU Cooling FAN Power Connector

PIN No.	Signal Description
1	Ground
2	+12V
3	Pull-up +5V (Reserved for fan sense)

Ÿ J16/ J22 : Serial Port-1/Port-2 Connector (D-SUB 9-pin)

PIN No.	Signal Description
1	Data Carrier Detect (DCD)
2	Receive Data (RXD)
3	Transmit Data (TXD)
4	Data Terminal Ready (DTR)
5	Ground (GND)
6	Data Set Ready (DSR)
7	Request to Send (RTS)
8	Clear to Send (CTS)
9	Ring Indicator (RI)

Ÿ J18 : PS/2 Mouse Connector (6-pin Mini-DIN)

PIN No.	Signal Description
1	Mouse Data
2	N/C
3	Ground
4	+5V
5	Mouse Clock
6	N/C

∩ J17 : Flat Panel Display Module Interface

PIN No.	Signal Description	PIN No.	Signal Description
1	P0	2	P1
3	P2	4	P3
5	P4	6	P5
7	P6	8	P7
9	P8	10	P9
11	P10	12	P11
13	P12	14	P13
15	P14	16	P15
17	Ground	18	P16
19	SHFCLK	20	P17
21	Ground	22	Ground
23	P18	24	P19
25	P20	26	P21
27	P22	28	P23
29	FLM	30	ENAVEE
31	LP	32	PCLK
33	M	34	+5V
35	+12V	36	+5V
37	+12V	38	+5V
39	Ground	40	Ground

∩ J19 : VGA Connector (2x5 Shrouded Connector)

PIN	Signal Description	PIN	Signal Description
1	RED	6	DDC_CLK
2	GREEN	7	Ground
3	BLUE	8	DDC_DATA
4	VSYNC	9	Ground
5	HSYNC	10	N/C

∩ J20 : External PS/2 Mouse Connector

PIN No.	Signal Description
1	Mouse Clock
2	Mouse Data
3	N/C
4	Ground
5	+5V

✧ J23 : External USB Interface Connector

PIN No.	Signal Description	PIN No.	Signal Description
1	+5V	2	N/C
3	SBD0- (USBP0-)	4	Ground
5	SBD0+ (USBP0+)	6	SBD1+ (USBP1+)
7	Ground	8	SBD1- (USBP1-)
9	N/C	10	+5V

✧ J24 : External Keyboard Connector

PIN No.	Signal Description
1	Keyboard Clock
2	Keyboard Data
3	N/C
4	Ground
5	+5V

✧ J25 : PS/2 Keyboard Connector (6-pin Mini-DIN)

PIN No.	Signal Description
1	Keyboard Data
2	N/C
3	GND
4	+5V
5	Keyboard Clock
6	N/C

✧ CN1/CN2 : PC/104 Interface

PIN No.	Signal Name	PIN No.	Signal Name	PIN No.	Signal Name	PIN No.	Signal Name
B1	GND	A1	IOCHKJ	C0	GND	D0	GND
B2	RSTDRV	A2	SD7	C1	SBHEJ	D1	MEM16J
B3	+5V	A3	SD6	C2	LA23	D2	IO16J
B4	IRQ9	A4	SD5	C3	LA22	D3	IRQ10
B5	-5V	A5	SD4	C4	LA21	D4	IRQ11
B6	DRQ2	A6	SD3	C5	LA20	D5	IRQ12
B7	-12V	A7	SD2	C6	LA19	D6	IRQ15
B8	0WSJ	A8	SD1	C7	LA18	D7	IRQ14
B9	+12V	A9	SD0	C8		LA17	D8
	DACK0J B10		N/C	A10	IOCRDY	C9	MEMRJ
	D9	DRQ0					
B11	SMEWJ	A11	AEN	C10	MEMWJ	D10	DACK5J
B12	SMERJ	A12	SA19	C11	SD8	D11	DRQ5
B13	IOWJ	A13	SA18	C12	SD9	D12	DACK6J

PIN No.	Signal Name	PIN No.	Signal Name	PIN No.	Signal Name	PIN No.	Signal Name
B14	IORJ	A14	SA17	C13	SD10	D13	DRQ6
B15	DACK3J	A15	SA16	C14	SD11	D14	DACK7J
B16	DRQ3	A16	SA15	C15	SD12	D15	DRQ7
B17	DACK1J	A17	SA14	C16	SD13	D16	+5V
B18	DRQ1	A18	SA13	C17	SD14	D17	MASTERJ
B19	REFRSH	A19	SA12	C18	SD15	D18	GND
B20	ATCLK	A20	SA11	C19	N/C	D19	GND
B21	IRQ7	A21	SA10				
B22	IRQ6	A22	SA9				
B23	IRQ5	A23	SA8				
B24	IRQ4	A24	SA7				
B25	IRQ3	A25	SA6				
B26	DACK2J	A26	SA5				
B27	TC	A27	SA4				
B28	BALE	A28	SA3				
B29	+5V	A29	SA2				
B30	OSC	A30	SA1				
B31	GND	A31	SA0				
B32	GND	A32	GND				

CHAPTER 3

System Installation

This chapter provides you with instructions on how to set up your system. The additional information shows you how to install M-systems Flash disk, set up LCD display and handle WDT operation in software program.

3-1 Socket 370 Celeron and P-II/III Processor

Installing CPU

- 1) Lift the handling lever of CPU socket outwards and upwards to the other end.
- 2) Align the processor pins with pin holes on the socket. Make sure that the notched corner or dot mark (pin 1) of the CPU corresponds to the socket's bevel end. Then press the CPU gently until it fits into place. If this operation is not easy or smooth, don't do it forcibly. You need to check and rebuild the CPU pin uniformly.
- 3) Push down the lever to lock processor chip into the socket.
- 4) Follow the installation guide of cooling fan or heat sink to mount it on CPU surface and lock it on the socket 370.
- 5) Be sure to follow particular CPU speed and voltage type to adjust the jumper settings properly.

Removing CPU

- 1) Unlock the cooling fan first.
- 2) Lift the lever of CPU socket outwards and upwards to the other end.
- 3) Carefully lift up the existing CPU to remove it from the socket.
- 4) Follow the steps of installing a CPU to change to another one or place handling bar to close the opened socket.

3-2 Main Memory

This 3307555 provides four 168-pin Dual In-line Memory Modules (**DIMM**) to support on-board main memory. The maximum memory size for 3.3V EDO DRAM or SDRAM is 1GB. Normally, the DIMM used could be either 3.3V EDO (Extended Data Out) memory with speed less than 70ns or 3.3V SDRAM (Synchronized DRAM) with speed less than 100ns (-10). If you adopt 100MHz system clock, you need to use SDRAM with speed less than 80ns (-8). It is better to use PC100-compliant memory chip on your system.

For system compatibility and stability, don't use memory module without brand. You can also use the single or double-side DIMM without parity check and ECC function.

Watch out the contact and lock integrity of memory module with socket, it will impact on the system reliability. Follow normal procedure to install your DRAM module into memory socket. Before locking, make sure that the module has been fully inserted into card slot.

NOTE : For maintaining system stability, don't change any of DRAM parameters in BIOS setup to upgrade your system performance except for getting technical information.

3-3 M-systems Flash Disk

3307555 reserves one 32-pin DIP sockets for installing M-systems Flash disk from 2MB to 144MB. This operation structure is running with pure ISA-bus without PnP (Plug and Play) function. Before installing, make certain that I/O address jumper setting is set on right position to prevent unworkable system due to I/O resource conflict. Do remember to follow DOC (DiskOnChip) installation procedure. Otherwise, the Flash chip is possible to be burned out due to incorrect installation.

Installing DOC

Align the DOC with pin holes on the socket. Make sure that the notched corner or dot mark (pin 1) of DOC corresponds to notched corner of the socket. Then press the DOC gently until it fits into place. If installation procedure is correct, the Flash disk can be viewed as a normal hard disk to access read/write data.

WARNING : Please ensure that your DOC is properly inserted. Placing the DOC in reverse will cause severe damage to it.

If you want to boot from this Flash disk, it is necessary to refer to the application note from M-systems. You can easily obtain relative information from M-systems shipping package (such as product manual) or Web-site <http://www.m-sys.com>.

3-4 Installing the Single Board Computer

To install your 3307555 into standard chassis or proprietary environment, you need to perform the following :

- Step 1 : Check all jumpers setting on proper position
- Step 2 : Install and configure CPU and memory module on right position
- Step 3 : Place 3307555 into the dedicated position in your system
- Step 4 : Attach cables to existing peripheral devices and secure it

NOTE : Please refer section 3-4-1 to 3-4-3 to install display driver and setup your system.

3-4-1 CHIPS 69000 Graphics Controller

The following table will show you how to enable and disable on-board C&T 69000 VGA function by putting jumpers at proper position.

JP10	FUNCTION
1-2	Enable on-board VGA
2-3	Disable on-board VGA

The on-board graphics controller adopts CHIPS 69000 that integrates high performance memory technology for the graphics frame buffer. Based on the proven HiQVideo graphics accelerator core, the 69000 combines state-of-the-art flat panel controller capabilities with low power, high performance integrated memory. It incorporates 2MB of proprietary integrated SDRAM for the graphics/video frame buffer. The integrated SDRAM memory can support up to 83MHz operation, thus increasing the available memory bandwidth for the graphics subsystem to support high color/high resolution application.

The 69000 supports a wide variety of monochrome and color Single-Panel, Single-Drive and Dual-Panel, Dual Drive, standard and high-resolution, passive STN and active matrix TFT/MIM LCD, and EL panels. It is designed to support high performance graphics and video acceleration for all supported display resolutions, display types, and color modes. This PCI device 69000 can be configured to operate an analog CRT monitor and flat panel at the same time.

Display Modes Supported

The 69000 supports the modes which appear in the table below.

Resolution	Color (bpp)	Refresh Rates (Hz)
640x480	8	60, 75, 85
640x480	16	60, 75, 85
640x480	24	60, 75, 85
800x600	8	60, 75, 85
800x600	16	60, 75, 85
800x600	24	60, 75, 85
1024x768	8	60, 75, 85
1024x768	16	60, 75, 85
1280x1024	8	60

3307555 utilizes on-board CHIPS 69000 and optional panel display module to support 16 types of panels. You can select one of sixteen LCD panel type by BIOS panel setting in Advanced CMOS Setup.

3-4-3 Driver Support

3307555 provides one CD-Title to support on-board VGA device drivers in various operating systems. This CD-Title only includes one directory **\vga69000**. Before installing the device driver, please see the reference files in each sub-directory. **You can not install driver from CD-Title directly.**

- vga69000: supports NT3.5, NT4.0, WIN95 and Win98 environment.

Important Notice !

For the successful installation of VGA driver in NT3.51 environment, you should build a diskette with the VGA drivers to support valid data path '3Disk1'. Please prepare one diskette and create a directory \disk1 under its root. Copy all files under \vga69000\NT_35 from the CD-Title into \disk1. When the computer ask you for VGA drivers during the installation of NT3.51, the VGA drivers are all located in the diskette.

3-5 Watch Dog Timer Programming

There are two manners to activate the Watch-Dog Timer (WDT) function. One is to utilize hardware jumper setting and programmed by software command. After this feature is enabled, a system reset will be generated unless a application triggers the timer periodically within time-out period. This allows the system to restart in an orderly way in case of any abnormal condition is found. Another one is to program super I/O W83977ATF chip to start WDT time-out counting. It is recommended to use first approach. The second choice is comparatively difficult and complicated. In addition, you can also connect WDT output to NMI input by setting JP6 jumper to generate NMI event to support special interrupt service routine.

An optional two-port WDT is provided on 3307555. This WDT comes with 8 possible ranges of time intervals from 500 ms to 64 sec., which can be adjusted by setting jumper positions. It could be enabled and programmed by reading I/O port 0533H or 0543H to issue trigger continuously, and disabled by reading I/O port 0033H or 0343H. A tolerance of 30% timer limit must be considered. For instance, if the time-out interval is set to 1second, the WDT trigger command must be issued within 700ms at least.

The below example gives you a reference algorithm for WDT programming via I/O port 0533H and 0033H in your application program :

Enable WDT

MOV DX, 0533H

Re-trigger WDT

IN AL, DX

Disable WDT

MOV DX, 0533H

IN AL, DX

MOV DX, 0033H

IN AL, DX

NOTE : Please directly contact your technical specialist to get WDT programming information on super I/O chip W83977ATF for long time-out interval support from 0.5 minutes to 254.5 minutes.

CHAPTER 4

BIOS Setup Information

3307555 is equipped with the AMI BIOS stored in Flash ROM. This BIOS has a built-in Setup program that allows users to modify the basic system configuration easily. This type of information is stored in CMOS RAM so that it is retained during power-off periods. When system is turned on, 3307555 communicates with peripheral devices and check its hardware resources against the configuration information stored in the CMOS memory. If any error is detected, or the CMOS parameters need to be initially defined, the diagnostic program will prompt the user to enter the SETUP program. Some errors are significant enough to abort the start-up.

4.1 Entering Setup

Turn on or reboot the computer. When the message “Hit if you want to run SETUP” appears, press key immediately to enter BIOS setup program.

If the message disappears before you respond, but you still wish to enter Setup, please restart the system to try “COLD START” again by turning it OFF and then ON, or touch the "RESET" button. You may also restart from “WARM START” by pressing <Ctrl>, <Alt>, and <Delete> keys simultaneously. If you do not press the keys at the right time and the system will not boot, an error message will be displayed and you will again be asked to,

Press <F1> to Run SETUP or Resume

In HIFLEX BIOS setup, you can use the keyboard to choose among options or modify the system parameters to match the options with your system. The table below will show you all of keystroke functions in BIOS setup.

EDITING KEYS	FUNCTION
<Tab>	Move to the next field
←↑→↓	Move the next field to the left, above, right, or below
<Enter>	Select in the current field
+ / —	Increments / Decrements a value
<Esc>	Close the current operation and return to previous level
<PgUp>	Returns to the previous option
<PgDn>	Advances to the next option
<F2>/<F3>	Select background color
<F10>	Show “Save current settings and exit (Y/N)” in main menu

4.2 Main Menu

Once you enter 3307555 AMI BIOS CMOS Setup Utility, the Main Menu will appear on the screen. The Main Menu allows you to select from eleven setup functions and two exit choices. Use arrow keys to switch the items and press <Enter> key to accept or enter the sub-menu.

<p>AMI BIOS HIFLEX SETUP UTILITY-VERSION 1.21 (C) 1998 American Megatrends , Inc. All Rights Reserved</p>
<p>Standard CMOS Setup Advanced CMOS Setup Advanced Chipset Setup Power Management Setup PCI/Plug and Play Setup Peripheral Setup Hardware Monitor Setup Change User Password Change Supervisor Password Auto-Detect Hard Disks Auto Configuration with Optimal Settings Auto Configuration with Fail Safe Settings Save Settings and Exit Exit Without Saving</p>
<p>Standard CMOS setup for changing time, date, hard disk type, etc. ESC : Exit ↑ ↓: Sel F2/F3 : Color F10 : Save & Exit NOTE : It is strongly recommended to reload Optimal Setting if CMOS is lost or BIOS is updated.</p>

4.3 CMOS Setup Reference Table

This setup reference table includes all the Optimal, Failsafe, and Other options setting in each BIOS setup item. It is very easy to cross reference. If you want to go details, you can directly refer to item description in sub-section.

⚠ ADVANCED CMOS SETUP DEFAULTS

BIOS Setup Items	Optimal Default	Failsafe Default	Other Options
Quick Boot	Enabled	Enabled	
1st Boot Device	IDE-0	IDE-0	IDE-1, IDE-2, IDE-3, Floppy, CDROM, ATAPI ZIP, LS-120, SCSI, Network
2nd Boot Device	Floppy	Floppy	IDE-1,....,CDROM
3rd Boot Device	ATAPI ZIP	ATAPI ZIP	IDE-1,....,ATAPI ZIP
4th Boot Device	Disabled	Disabled	IDE-1,....,CDROM
Try Other Boot Device	Yes	Yes	No
S.M.A.R.T. for Hard Disks	Disabled	Disabled	Enabled
BootUp Num-Lock	On	On	Off
PS/2 Mouse Support	Enabled	Enabled	Disabled
System Keyboard	Absent	Absent	Present
Primary Display	Absent	Absent	VGA/EGA,....,Mono
Password Check	Setup	Setup	Always
Boot To OS/2 > 64MB	No	No	Yes
System BIOS Cacheable	Enabled	Disabled	
C000, 16K Shadow	Cached	Cached	Enabled, Disabled
C400, 16K Shadow	Cached	Cached	Enabled, Disabled
C800, 16K Shadow	Cached	Cached	Enabled, Disabled
CC00, 16K Shadow	Disabled	Disabled	Cached, Enabled
D000, 16K Shadow	Disabled	Disabled	Cached, Enabled
D400, 16K Shadow	Disabled	Disabled	Cached, Enabled
D800, 16K Shadow	Disabled	Disabled	Cached, Enabled
DC00, 16K Shadow	Disabled	Disabled	Cached, Enabled

⚠ ADVANCED CHIPSET SETUP DEFAULTS

BIOS Setup Items	Optimal Default	Failsafe Default	Other Options
Configure SDRAM Timing by SPD	Disabled	Disabled	Enabled
SDRAM RAS# to CAS# delay	3 SCLKs	3 SCLKs	2 SCLKs
SDRAM RAS# Precharge	3 SCLKs	3 SCLKs	2 SCLKs
SDRAM CAS# Latency	3 SCLKs	3 SCLKs	2 SCLKs
SDRAM Leadoff Cmd Timing	Auto	Auto	4 SCLKs, 3 SCLKs
DRAM Integrity Mode	Non-ECC	Non-ECC	EC-Only, ECC H/W
DRAM Refresh Rate	15.6 us	15.6 us	31.2 us, 62.4 us, 124.8 us, 249.6 us
Memory Hole	Disabled	Disabled	512KB-640KB, 15MB-16MB
8bit I/O Recovery Time	1 Sysclk	1 Sysclk	Disabled, 2, 3, 4, 5, 6, 7, 8 Sysclk

BIOS Setup Items	Optimal Default	Failsafe Default	Other Options
16bit I/O Recovery Time	1 Sysclk	1 Sysclk	Disabled,2,3,4 Sysclk
USB Passive Release	Enabled	Enabled	Disabled
PIIX4 Passive Release	Enabled	Enabled	Disabled
PIIX4 Delayed Transaction	Disabled	Disabled	Enabled
Spread Spectrum Control	Disabled	Disabled	Enabled
USB Function	Disabled	Disabled	Enabled
USB Keyboard Legacy Support	Enabled	Enabled	Disabled
CMOS RAM CLEAR FUNCTION	Disabled	Disabled	Enabled
LCD CRT Selection	CRT Only	CRT Only	Simultaneous, LCD Only
LCD Type	Type 7	Type 7	Type 1, 2, 3, 4, 5, 6, 8, 9, 10, 11, 12, 13, 14, 15, 16

⚡ POWER MANAGEMENT SETUP DEFAULTS

BIOS Setup Items	Optimal Default	Failsafe Default	Other Options
Power Management / APM	Enabled	Disabled	
Green PC Monitor Power State	Off	Off	Stand By, Suspend
Video Power Down Mode	Disabled	Disabled	Stand By, Suspend
Hard Disk Power Down Mode	Disabled	Disabled	Stand By, Suspend
Standby Time Out (Minute)	Disabled	Disabled	1, 2, 4, 8, 10, 20, 30, 40, 50, 60 Min.
Suspend Time Out (Minute)	Disabled	Disabled	1, 2, 4, 8, 10, 20, 30, 40, 50, 60 Min.
Throttle Slow Clock Ratio	50 – 62.5%	50 – 62.5%	0-12.5%, 12.5-25%, 25-37.5%, 37.5-50%, 62.5-75%, 75-87.5%
Display Activity	Ignore	Ignore	Monitor
Device 6 (Serial Port 1)	Monitor	Monitor	Ignore
Device 7 (Serial Port 2)	Monitor	Monitor	Ignore
Device 8 (Parallel Port)	Ignore	Ignore	Monitor
Device 5 (Floppy disk)	Monitor	Monitor	Ignore
Device 0 (Primary master IDE)	Monitor	Monitor	Ignore
Device 1 (Primary slave IDE)	Ignore	Ignore	Monitor
Device 2 (Secondary master IDE)	Monitor	Monitor	Ignore
Device 3 (Secondary slave IDE)	Ignore	Ignore	Monitor
System Thermal	Ignore	Ignore	Monitor
Thermal Slow Clock Ratio	50 – 62.5%	50 – 62.5%	0 – 12.5%, 12.5 – 25%, 25 – 37.5%, 37.5 – 50%, 62.5 – 75%
CPU Critical Temperature	75°C/167°C	75°C /167°C	Disabled, 45°C/113°F, .50°C/122°F, 55°C/131°F, 60°C/140°F, 65°C/149°F, 70°C/158°F, 75°C/167°F
Power Button Function	On/Off	On/Off	Suspend
Ring Resume From Soft Off	Disabled	Disabled	Enabled

⚠ PCI / PnP SETUP DEFAULTS

BIOS Setup Items	Optimal Default	Failsafe Default	Other Options
Plug and Play Aware O/S	No	No	Yes
Clear NVRAM	No	No	Yes
PCI Latency Timer (PCI Clocks)	64	64	32, 96, 128, 160, 192, 224, 248
PCI VGA Palette Snoop	Disabled	Disabled	Enabled
Allocate IRQ to PCI VGA	Yes	Yes	No
PCI IDE BusMaster	Disabled	Disabled	Enabled
OffBoard PCI IDE Card	Auto	Auto	Slot1, Slot2, Slot3, Slot4
OffBoard PCI IDE Primary IRQ	Disabled	Disabled	INTA, INTB, INTC, INTD, Hardwired
OffBoard PCI IDE Secondary IRQ	Disabled	Disabled	INTA, INTB, INTC, INTD, Hardwired
PCI Slot1 IRQ Priority	Auto	Auto	3, 4, 5, 7, 9, 10, 11
PCI Slot2 IRQ Priority	Auto	Auto	3, 4, 5, 7, 9, 10, 11
PCI Slot3 IRQ Priority	Auto	Auto	3, 4, 5, 7, 9, 10, 11
PCI Slot4 IRQ Priority	Auto	Auto	3, 4, 5, 7, 9, 10, 11
DMA Channel 0	PnP	Pnp	ISA/ EISA
DMA Channel 1	PnP	Pnp	ISA/ EISA
DMA Channel 3	PnP	Pnp	ISA/ EISA
DMA Channel 5	PnP	Pnp	ISA/ EISA
DMA Channel 6	PnP	Pnp	ISA/ EISA
DMA Channel 7	PnP	Pnp	ISA/ EISA
IRQ3	PCI/ PnP	PCI/ PnP	ISA/ EISA
IRQ4	PCI/ PnP	PCI/ PnP	ISA/ EISA
IRQ5	PCI/ PnP	PCI/ PnP	ISA/ EISA
IRQ7	PCI/ PnP	PCI/ PnP	ISA/ EISA
IRQ9	PCI/ PnP	PCI/ PnP	ISA/ EISA
IRQ10	PCI/ PnP	PCI/ PnP	ISA/ EISA
IRQ11	PCI/ PnP	PCI/ PnP	ISA/ EISA
IRQ12	PCI/ PnP	PCI/ PnP	ISA/ EISA
IRQ14	PCI/ PnP	PCI/ PnP	ISA/ EISA
IRQ15	PCI/ PnP	PCI/ PnP	ISA/ EISA

⚠ PERIPHERAL SETUP DEFAULTS

BIOS Setup Items	Optimal Default	Failsafe Default	Other Options
OnBoard FDC	Auto	Auto	Enabled, Disabled
OnBoard Serial PortA	Auto	Auto	3F8h/COM1, 2F8h/COM2, 3E8h/COM3, 2E8h/COM4, Disabled
OnBoard Serial PortB	Auto	Auto	3F8h/COM1, 2F8h/COM2, 3E8h/COM3, 2E8h/COM4, Disabled

BIOS Setup Items	Optimal Default	Failsafe Default	Other Options
OnBoard IR Port	Disabled	Disabled	3F8h/COM1, 2F8h/COM2, 3E8h/COM3, 2E8h/COM4, Auto
IR Mode Select	N/A	N/A	IRDA, ASK-IR, FIR
IR IRQ Select	N/A	N/A	3, 4, 5, 9, 10, 11, 12
IR DMA Select	N/A	N/A	0, 1, 3
OnBoard Parallel Port	Auto	Auto	Disabled, 378h, 278h, 3BCh
Parallel Port Mode	Bi-Dir	Bi-Dir	EPP, ECP, Normal
EPP Version	N/A	N/A	1.7, 1.9
Parallel Port IRQ	Auto	Auto	5, 7
Parallel Port DMA Channel	N/A	N/A	0, 1, 3
OnBoard IDE	Both	Both	Disabled, Primary, Secondary

W HARDWARE MONITOR SETUP DEFAULTS

BIOS Setup Items	Optimal Default	Failsafe Default	Other Options
CPU Current Temperature	0°C/32°F	0°C /32°F	

4.4 Standard CMOS Setup Menu

This setup page includes all the items in a standard compatible BIOS. Use the arrow keys to highlight the item and then use the <PgUp>/<PgDn> or <+>/<-> keys to select the value or number you want in each item and press <Enter> key to certify it.

Follow command keys in CMOS Setup table to change **Date**, **Time**, **Drive type**, and **Boot Sector Virus Protection Status**.

4.5 Advanced CMOS Setup Menu

This setup includes all of the advanced features in the system. The detail descriptions are specified as follows.

Quick Boot

Set “Disabled” for normal booting or select “Enabled” to skip minor BIOS test items to obtain quick boot response.

Boot Up Sequence

This category includes six items to determine which drive computer searches first for the Disk Operating System (DOS). The default ARMD (ATAPI Removable Media Device) emulation type is set to popular drive type LS-120 and ATAPI ZIP. There are many choices of booting devices to boot up system. User can select “Disabled”, “IDE-0”, “IDE-1”, “IDE-2”, “IDE-3”, “Floppy”, “LS-120”, “ATAPI ZIP”, “CDROM”, “SCSI”, or “NETWORK”.

Boot Up Num-Lock

Select “On” to enable numeric function of the numeric keypad, or “Off” to disregard it.

PS/2 Mouse Support

Select “Enabled” to enable PS/2 mouse function, or “Disabled” to release IRQ12 interrupt for other ISA-bus I/O devices.

System Keyboard

This option will be used to neglect “keyboard error” while you choose *Absent* setting in your BIOS setup and system has no keyboard attached.

Primary Display

Chooses *Absent*, *VGA/EGA*, *CGA40x25*, *CGA80x25*, or *Mono* to meet your monitor type. If you select *Absent*, the “CMOS Display Type Wrong” message will be ignored regardless the mismatched display card.

Password Check

This option enables the password checking when the system boots up or runs CMOS Setup. It only takes effect after setting Change Supervisor Password.

Setup : This option will force system to check password before running Setup if you have already entered the current user password in “Change User Password”. By that time, the system will be only able to boot but deny accessing Setup.

Always : Password prompt appears every boot-up. The system will not boot and deny access Setup with invalid password. The best way is to clear CMOS or try to reload BIOS Setup to boot up system.

Boot To OS/2 > 64MB

You should set this option to “Yes” to support OS/2 environment.

System BIOS Cacheable

Enables this option to enhance system performance by shadowing and caching system BIOS. When disabled, this BIOS shadow function will be ignored.

Video BIOS Shadow

Select “Cached” option to get more higher display performance by shadowing and caching VGA BIOS. If user chooses “Enabled” option, only BIOS shadow function is active. The “Disabled” option will ignore this BIOS caching and shadowing function.

Shadow Memory (from address C000 – DFFF, 16K per segment)

Each of segments provides three options “Disabled”, “Enabled”, and “Cached” for faster adapter’s ROM execution. However this shadow function is Chipset oriented and dependent on system hardware feature. In general, C000 and C800 will be allocated for VGA BIOS and set to *Cached* to get higher display performance by shadowing and caching feature. If user chooses *Enabled* setting, only BIOS shadow function is active.

4.6 Advanced Chipset Setup Menu

This setup is very important to keep system stability. If you are not technical person, do not attempt to change any parameters. The best way is to choose optimal default setting.

Configure SDRAM Timing by SPD

This option provides DIMM plug-and-play support by Serial Presence Detect (SPD) mechanism via the System Management Bus (SMBus) interface. You can disable this option to manage the following four SDRAM timing options by yourself. In addition, SDRAM operating timings may follow serial presence from EEPROM content by setting this option to “Enabled”, and all of SDRAM timing options will be not available and hidden.

SDRAM RAS# to CAS# delay

This option controls the number of SCLKs (SDRAM Clock) from a row activate command to a read or write command. If your system installs good quality of SDRAM, you can set this option to “2 SCLKs” to obtain better memory performance. Normally, the option will be set to 3 SCLKs.

SDRAM RAS# Precharge

This option controls the number of SCLKs for RAS# precharge. If your system installs good quality of SDRAM, you can set this option to “2 SCLKs” to obtain better memory performance.

SDRAM CAS# Latency

This option controls the number of SCLKs between the time a read command is sampled by the SDRAMs and the time the North Bridge, 82443BX, samples correspondent data from the SDRAMs. For a registered DIMM with CAS# Latency = 2, this option should be set to “2 SCLKs” to acquire better memory performance.

SDRAM Leadoff Cmd Timing

This option is used to control when the SDRAM command pins (SRASx#, SCASx# and Wex#) and CSx# are considered valid on leadoffs for CPU cycles. If you select *Auto*, this timing will be automatically initialized and set by BIOS from CPU speed detection. For Desktop platforms, it might be set to 4 SCLKs. In general, another option 3 SCLKs will be set to meet Mobile platforms.

DRAM Integrity Mode

There are three options *Non-ECC*, *EC-Only* (Error Check Only) and *ECC Hardware* (Error Checking and Correction) in this feature. The DRAM integrity mode will be implemented by the parity algorithm when this option is set to “Non-ECC”.

DRAM Refresh Rate

This option specifies the refresh rate frequency for the installed system memory SDRAM DIMMs. If you have good quality of DRAM, you can choose longer refresh rate to get better system performance.

Memory Hole

This option allows the end user to specify the location of a memory hole for memory space requirement from ISA-bus cards.

8bit I/O Recovery Time

This option specifies the length of the delay (in SYSCLKs) inserted between consecutive 8-bit I/O operations.

16bit I/O Recovery Time

This option specifies the length of the delay (in SYSCLKs) inserted between consecutive 16-bit I/O operations.

USB Passive Release

When enabled, this allows PIIX4 to use Passive Release to obtain better USB performance while transferring control information or data for USB transactions. When disabled, PIIX4 will perform PCI accesses for USB without using Passive Release.

PIIX4 Passive Release

Choose the "Enabled" option to help raise the available bandwidth of the PCI bus for acquiring higher PCI bus performance.

PIIX4 Delayed Transaction

Choose the "Enabled" option to obtain higher PCI bus performance for slower ISA bus application.

Spread Spectrum Control

This option is for EMI test issue only.

USB Function

This option will enable on-chip USB function to support USB (Universal Serial Bus) peripheral devices if user chooses the “Enabled” setting.

USB Keyboard Legacy Support

This feature will be automatically disabled and hidden if user chooses the “Disabled” setting from the foregoing USB Function option. Otherwise, enabling this option provides support for USB-keyboard without auxiliary driver under DOS environment.

CMOS RAM CLEAR FUNCTION

If your system supports Y2K RTC, you should set this option to *Enabled* to support hardware CMOS clearing operation.

LCD CRT Selection

There are three options, “CRT Only”, “LCD Only”, and “Simultaneous” used to support display function. If you want to obtain better display quality and flexible refresh rate, you can choose “CRT Only” option. The default setting is *CRT Only*.

LCD Type

There are sixteen options from “Type 1” to “Type 16” used to support LCD panel display function. The final Panel Type will be decided by CMOS setting. You can find out the supporting resolution on page 2-4. The default setting is *Panel Type 7*.

4.7 Power Management Setup Menu

This APM (Advanced Power Management) determines how much power energy can be saved by setting below items to handle system power resource. The following descriptions will specify the definition of each item in details.

Power Management/APM

Using this feature to control system power resources. Set this option to “Enabled” to enable power management function and effective based on following parameter settings.

Green PC Monitor Power State

This option is used to decide what kind of power states are effective. There are three options “Stand By”, “Suspend”, and “Off” in this feature. The “Stand By” option is to turn off light power by handling of Monitor signals. The other “Suspend” mode is to turn off heavy power. And the other one, “Off” state, is really to turn off the power of the monitor.

Video Power Down Mode

This option specifies the power conserving state that the VESA VGA video subsystem enters after the specified period of display inactivity has expired.

Hard Disk Power Down Mode

This option specifies the power management state that the HDD enters after the specified period of hard drive inactivity has expired. It is the same as video power control. If user chooses “Stand By” or “Suspend”, it will depend on period of parameter “Stand By Time out” or “Suspend Time out”.

Stand by Time out (Minute)

This option specifies the length of the period of system inactivity while the computer is in Full-On power state before the computer is placed in Standby mode. When this length of time expires, the computer enters Standby Timeout state. In Standby mode, some power use is curtailed.

Suspend Time out (Minute)

This option is the same as **Stand by Time out** function. These two features will be enabled to monitor power of sub-items “Display Activity”, “Serial port”, “Parallel Port”, “Floppy”, “Pri-HDD”, and “Sec-HDD” independently. It is also used to control CPU throttle running function. All of sub-items will be ineffective in selection of disabling “Stand by Time out” or “Suspend Time out” even if it can be choosed by user in BIOS setup menu.

Throttle Slow Clock Ratio

This option specifies the speed at which the system clock runs in power saving modes. The settings are expressed as duty cycle of the STPCLK# signal. This duty cycle indicates the percentage of time the STPCLK# signal is asserted while in the throttle mode.

Display Activity

This option specifies if BIOS is to monitor activity on the display monitor for power conservation purposes. If set to *Monitor* and the computer is in a power saving state, BIOS watches for video display activity. The computer enters the full on power state if any activity occurs. BIOS reloads the Standby and Suspend timeout timers if activity occurs on the specified IRQ lines. If set to *Ignore*, video display monitor activity is not monitored.

Device 6/7/8/5/0/1/2/3 (Serial 1&2, Parallel, FDD, Pri/Sec HDD)

When set to *Monitor*, these options enable event monitoring on the specified hardware device. If set to *Monitor* and the computer is in a power saving state, BIOS watches for activity on the device with specified IRQ line. The computer enters the full on power state if any activity occurs. BIOS reloads the Standby and Suspend timeout timers if activity occurs on the specified device. No monitoring activity occurs if the option is set to *Ignore*. The settings for each of these options are Monitor or Ignore.

System Thermal

Set this option to *Monitor* for CPU thermal monitoring and speed down control. The system will automatically supervise the CPU environmental temperature. If the CPU surface temperature reaches the trip point set in Hardware Monitor Setup, the thermal detection will be effective and CPU will run in throttle control manner. The overall system performance will be reduced to half. This option is a trad-off of system performance and stability and configurable by user. The default setting is *Ignore*. You can choose *Monitor* setting to enable this thermal function.

Thermal Slow Clock Ratio

This option specifies the speed at which the system clock runs in thermal trip point. The settings are expressed as duty cycle of the STPCLK# signal. This duty cycle indicates the percentage of time the STPCLK# signal is asserted while in the over heat mode.

CPU Critical Temperature

Set this option to monitor CPU thermal trip point defined by user. If the System Thermal option in CMOS setup is set to "Monitor" state and CPU surface temperature is over this critical temperature, the system will automatically enter speed down mode.

Power Button Function

This item is used to handle soft power on/off regardless of time counting (generally speaking, it is 4 sec) if you set it to *On/Off*. You can easily power on/off system by pressing power button (toggle switch) directly. This feature is only available on system with ATX power control interface. If you use standard AT power supply, this option will be ignored. However choose the "Suspend" setting, system will be forced into suspend mode when user turn it off unless you can consecutively press the power button for more than 4 second to get in Soft off function.

Ring Resume From Soft Off

This item will be used to wake up system from remote ringing control under Soft Off condition. If you choose "Disabled" setting, the system will be not resumed by modem ring.

4.8 PCI/Plug and Play Setup

This section describes configuring the PCI bus system. PCI (Peripheral Component Interconnect) is a system which allows I/O devices to operate at speeds nearing CPU's when they communicate with own special components.

All of options described in this section are important and technical and it is strongly recommended that only experienced users could make any changes to the default settings.

Plug and Play Aware O/S

Set this option to “Yes” if the operating system installed in the computer is Plug and Play-aware. BIOS only detects and enables PnP ISA adapter cards that are required for system boot. The Windows 95 operating system detects and enables all other PnP-aware adapter cards. Windows 95 is PnP-aware. Set this option to “No” if the operating system (such as DOS, OS/2, Windows 3.x) does not use PnP. *You must set this option correctly or PnP-aware adapter cards installed in your computer will not be configured properly.*

Clear NVRAM

This option is used to clear NVRAM and check or update ESCD (Extended System Configuration Data) data after system power on. Set this option to *No* that will not clear NVRAM and the operation of update ESCD is effective in different ESCD data comparison. If you select the “Yes” setting, then the BIOS will update ESCD each time of power on.

PCI Latency Timer (PCI Clocks)

This option is used to control PCI latency timer period (follow PCI clocks). Based on PCI specification 2.1 or later and PCI bus frequency in system, user can select different timer to meet their PCI bus environment.

PCI VGA Palette Snoop

Some display cards that are non-standard VGA such as graphics accelerations or MPEG video cards may not show colors properly. User can choose “Enabled” setting to correct this display mismatch problem and support any ISA adapter card installed in the computer requires VGA palette snooping.

Allocate IRQ to PCI VGA

This option will be used to allocate IRQ for PCI VGA card. In general, some of PCI VGA cards need IRQ support.

PCI IDE BusMaster

Set this option to *Enabled* to specify that the IDE controller on the PCI local bus has bus mastering capability.

Off Board PCI IDE Card

This option specifies if an offboard PCI IDE controller adapter card is used in the computer. You must also specify the PCI expansion slot on the SBC (Single Board Computer) where the offboard PCI IDE controller card is installed. If an offboard PCI IDE controller is used, the onboard IDE controller on the SBC is automatically disabled. If *Auto* is selected, BIOS automatically determines the correct setting for this option. If you want to respectively control off board PCI IDE Primary/Secondary IRQ resources, you should set this option among *Slot 1* to *Slot 4*. Otherwise, all of these sub-options will be not available and hidden.

Off Board PCI IDE Primary/Secondary IRQ

This option specifies the PCI interrupt used by the primary/ secondary IDE channel on the offboard PCI IDE controller. The settings are *Disabled*, *INTA*, *INTB*, *INTC*, *INTD*, or *Hardwired* for installing off-board non-compliant PCI IDE card.

PCI Slot 1/2/3/4 IRQ Priority

These options specify the priority IRQ to be used for any PCI devices installed in PCI expansion slots 1 through 4. The settings are *Auto* (AMIBIOS automatically Determines the priority IRQ), (IRQ) 3, 4, 5, 7, 9, 10, or 11.

DMA Channel 0/1/3/5/6/7

These options specify if the named DMA channel is available for using on the ISA/EISA bus or PnP (Plug & Play).

IRQ 3/4/5/7/9/10/11/12/14/15

These options specify the bus that the named interrupt request lines (IRQs) are used on. These options allow you to specify IRQs for use by legacy ISA adapter

cards. These options determine if AMIBIOS should remove an IRQ from the pool of available IRQs passed to devices that are configurable by the system BIOS. The available IRQ pool is determined by reading the ESCD NVRAM. If more IRQs must be removed from the pool, the end user can use these PCI/PnP Setup to remove the IRQ by assigning the option to the ISA/EISA setting. All IRQs used by on-board I/O are configured as PCI/PnP.

4.9 Peripheral Setup

This section describes I/O resources assignment for all of on-board peripheral devices.

On Board FDC

If user wants to install different add-on super I/O card to connect floppy drives, set this field to *Disabled*. Otherwise, set it to *Auto* to call BIOS to automatically determine if the floppy controller should be enabled.

On Board Serial Port A/Port B

These fields control the resource assignments of two on-board serial interfaces SIO1 and SIO2. The following lists show current options in On Board Serial Port A/ Port B :

Auto > cannot set serial I/O resources by manual operation

Disabled > indicates on-board COM port function is ineffective

3F8h/COM1 > assign I/O address 3F8h to COM1

2F8h/COM2 > assign I/O address 2F8h to COM2

3E8h/COM3 > assign I/O address 3E8h to COM3

2E8h/COM4 > assign I/O address 2E8h to COM4

On Board IR Port

This option control the resource assignments of on-board serial port 3. The IR Mode Select has three settings IrDA, ASK IR, and FIR.

On Board Parallel Port

There are four optional items *Parallel Port Mode*, *EPP Version*, *Parallel Port IRQ*, and *Parallel Port DMA Channel* used to control on-board parallel port interface while user select I/O base address manually. The following lists are available options of on-board parallel port :

Auto > user can not control all of LPT port I/O resources

Disabled > on-board parallel port function is ineffective and N/A

378h > locate IRQ7 for this default I/O address

278h > assign this I/O address to LPT1

3BCh > assign this I/O address to LPT1

Parallel Port Mode :

This option specifies the parallel port mode. ECP and EPP are both bidirectional data transfer schemes that adhere to the IEEE P1284 specifications. This Parallel Port Mode includes four options “Normal”, “Bi-Dir”, “EPP”, and “ECP”. The optimal default setting is *Bi-Dir*.

Setting	Description
Normal	Uni-direction operation at normal speed
Bi-Dir	Bi-direction operation at normal speed
EPP	The parallel port can be used with devices that adhere to the Enhanced Parallel Port (EPP) specification. EPP uses the existing parallel port signals to provide asymmetric bidirectional data transfer driven by the host device.
ECP	The parallel port can be used with devices that adhere to the Extended Capabilities Port (ECP) specification. ECP uses the DMA protocol to achieve data transfer rates up to 2.5 Megabits per second. ECP provides symmetric bidirectional communication.

EPP Version :

This option is only valid if the **Parallel Port Mode** option is set to *EPP*. This option specifies the version of the Enhanced Parallel Port specification that will be used by AMIBIOS.

Parallel Port IRQ :

This option is only valid if the **Onboard Parallel Port** option is not set to *Disabled*. This option sets the IRQ used by the parallel port.

Parallel Port DMA Channel :

This option is only available if **On Board Parallel Port** is set to fixed I/O address and the setting of **Parallel Port Mode** is ECP. This option sets the DMA channel used by ECP-capable parallel port.

On Board IDE

This option specifies the onboard IDE controller channels that will be used. The settings are *Disabled*, *Primary*, *Secondary*, or *Both*.

4.10 Hardware Monitor Setup

This section display current CPU surface temperature based on LM75 thermal Detection. In general, the temperature tolerance will be within 3° C.

4.11 BIOS POST Check Point List

AMIBIOS provides all IBM standard Power On Self Test (POST) routines as well as enhanced AMIBIOS POST routines. The POST routines support CPU internal diagnostics. The POST checkpoint codes are accessible via the Manufacturing Test Port (I/O port 80h).

Whenever a recoverable error occurs during the POST, the system BIOS will display an error message describing the message and explaining the problem in detail so that the problem can be corrected.

During the POST, the BIOS signals a checkpoint by issuing one code to I/O address 80H. This code can be used to establish how far the BIOS has executed through the power-on sequence and what test is currently being performed. This is done to help troubleshoot faulty system board.

If the BIOS detects a terminal error condition, it will halt the POST process and attempt to display the checkpoint code written to port 80H. If the system hangs before the BIOS detects the terminal error, the value at port 80H will be the last

test performed. In this case, the terminal error cannot be displayed on the screen. The following POST checkpoint codes are valid for all AMIBIOS products with a core BIOS date of 07/15/95 version 6.27 (Enhanced).

Uncompressed Initialization Codes — The uncompressed initialization checkpoint hex codes are listed in order of execution :

Code	Description
D0	NMI is disabled. CPU ID saved. INIT code checksum verification will be started.
D1	Initializing the DMA controller, performing the keyboard controller BAT test, starting memory refresh, and going to 4GB flat mode.
D3	To start memory sizing.
D4	Returning to real mode. Executing any OEM patches and setting the stack next.

Code	Description
D5	Passing control to the uncompressed code in shadow RAM at E000:0000h. The INIT code is copied to segment 0 and control will be transferred to segment 0.
D6	Control is in segment 0. Next, checking if <Ctrl><Home> was pressed and verifying the system BIOS checksum. If either <Ctrl><Home> was pressed or the system BIOS checksum is bad, next will go to checkpoint code E0h. Otherwise, going to checkpoint code D7h.
D7	To pass control to interface module.
D8	Main BIOS runtime code is to be decompressed.
D9	Passing control to the main system BIOS in shadow RAM next.

Bootblock Recovery Codes — The bootblock recovery checkpoint hex codes are listed in order of execution :

Code	Description
E0	The onboard floppy controller if available is initialized. Next, beginning the base 512KB memory test.
E1	Initializing the interrupt vector table next.
E2	Initializing the DMA and Interrupt controllers next.
E6	Enabling the floppy drive controller and Timer IRQs. Enabling internal cache memory.
ED	Initializing the floppy drive.
EE	Start looking for a diskette in drive A: and read first sector of the diskette.
EF	A read error occurred while reading the floppy drive in drive A: .
F0	Next, searching for the AMIBOOT.ROM file in the root directory.
F1	The AMIBOOT.ROM file is not in the root directory.
F2	Next, reading and analyzing the floppy diskette FAT to find the clusters occupied by the AMIBOOT.ROM file.
F3	Start reading AMIBOOT.ROM file, cluster by cluster.
F4	The AMIBOOT.ROM file is not the correct size.
F5	Next, disabling internal cache memory.
FB	Next, detecting the type of Flash ROM.
FC	Erasing the Flash ROM.
FD	Programming the Flash ROM
FF	Flash ROM programming was successful. Next, restarting the system BIOS.

Uncompressed Initialization Codes — The following runtime checkpoint hex codes are listed in order of execution. These codes are uncompressed in F0000h shadow RAM.

Code	Description
03	The NMI is disabled. Next, checking for a soft reset or a power on condition.
05	The BIOS stack has been built. Next, disabling cache memory.
06	Uncompressing the POST code next.

Code	Description
07	Next, initializing the CPU and the CPU data area.
08	The CMOS checksum calculation is done next.
0B	Next, performing any required initialization before the keyboard BAT command is issued.
0C	The keyboard controller input buffer is free. Next, issuing the BAT command to the keyboard controller.
0E	The keyboard controller BAT command result has been verified. Next, performing any necessary INIT after the K/B controller BAT command test.
0F	The keyboard command byte is written next.
10	Next, issuing the pin 23 and 24 blocking and unblocking commands.
11	Next, checking if the <End> or <Ins> keys were pressed during power on.
12	To initialize CMOS if the <i>initialize CMOS RAM in every boot</i> is set or the <End> key is pressed. Going to disable DMA and Interrupt controllers.
13	The video display has been disabled. Port B has been initialized. Next, initializing the chipset.
14	The 8254 timer test will begin next.
19	The 8254 timer test is over. Starting the memory refresh test next.
1A	The memory refresh line is toggling. Checking the 15us on/off time next.
23	Reading the 8042 input port and disabling the MEGAKEY Green PC feature next. Making the BIOS code segment writable and performing any necessary configuration before initializing the interrupt vectors.
24	The configuration or setup required before interrupt vector initialization has completed. Interrupt vector init. is about to begin
25	Interrupt vector initialization is done. Clearing the password if the POST DIAG switch is on.
27	Any initialization before setting video mode to be done.
28	Going for monochrome mode and color mode setting.
2A	Bus initialization system, static, output devices will be done next, if present.
2B	Passing control to the video ROM to perform any required configuration before the video ROM test.
2C	To look for optional video ROM and give control.
2D	The video ROM has returned control to BIOS POST. Performing any required processing after the video ROM had control.
2E	Completed post-video ROM test processing. If the EGA/VGA controller is not found, performing the display memory read/write test next.
2F	EGA/VGA not found. Display memory R/W test about to begin.
30	Display memory R/W test passed. Look for retrace checking next.
31	Display memory R/W test or retrace checking failed. To do alternate display retrace checking.
32	Alternate display memory R/W test passed. To look for the alternate display retrace checking.
34	Video display checking is over. Setting the display mode next.
37	The display mode is set. Displaying the power on message next.
38	Initializing the bus input, IPL, and general devices next, if present.

Code	Description
39	Displaying bus initialization error message.
3A	The new cursor position has been read and saved. Displaying the <i>Hit </i> message next.
40	Preparing the descriptor tables next.
42	Entering protected mode for the memory test next.
43	Entered protected mode. Enabling interrupts for diagnostics mode next.
44	Interrupts enabled if the diagnostics switch is on. Initializing data to check memory wraparound at 0:0 next.
45	Data initialized. Checking for memory wraparound at 0:0 and finding the total system memory size next.
46	The memory wraparound test has completed. The memory size calculation has been done. Writing patterns to test memory next.
47	The memory pattern has been written to extended memory. Writing patterns to the base 640 KB memory test.
48	Patterns written in base memory. Determining the amount of memory below 1MB next.
49	The amount of memory below 1MB has been found and verified. Determining the amount of memory above 1MB memory next.
4B	The amount of memory above 1MB has been found and verified. Checking for a soft reset and clearing the memory below 1MB for the soft reset next. If this is a power on situation, going to checkpoint 4Eh next.
4C	The memory below 1MB has been cleared via a soft reset. Clearing the memory above 1MB next.
4D	The memory above 1MB has been cleared via soft reset. Saving the memory size next. Going to checkpoint 52h next.
4E	The memory test started, but not as the result of a soft reset. Displaying the first 64KB memory size next.
4F	Memory size display started. This will be updated during memory test. Performing the sequential and random memory test next.
50	Memory testing/initialization below 1MB completed. Going to adjust displayed memory size for relocation and shadowing.
51	The memory size display was adjusted for relocation and shadowing. Testing the memory above 1MB next.
52	The memory above 1MB has been tested and initialized. Saving the memory size information next.
53	The memory size information and the CPU registers are saved. Entering real mode next.
54	Shutdown was successful. The CPU is in real mode. Disabling the Gate A20 line, parity, and the NMI next.
57	The A20 address line, parity, and the NMI are disabled. Adjusting the memory size depending on relocation and shadowing next.
58	The memory size was adjusted for relocation and shadowing. Clearing the <i>Hit </i> message next.
59	The <i>Hit </i> message is cleared. The <i><WAIT<<></i> message is displayed. Starting the DMA and interrupt controller test next.

Code	Description
60	The DMA page register test passed. To do DMA#1 base register test.
62	DMA#1 base register test passed. To do DMA#2 base register test.
65	DMA#2 base register test passed. To program DMA unit 1 and 2.
66	DMA unit 1 and 2 programming over. To initialize 8259 interrupt controller.
7F	Extended NMI sources enabling is in progress.
80	The keyboard test has started. Clearing the output buffer and checking for stuck keys. Issuing the keyboard reset command next.
81	A keyboard reset error or stuck key was found. Issuing the keyboard Controller interface test command next.
82	The keyboard controller interface test completed. Writing the command byte and initializing the circular buffer next.
83	Command byte written, Global data init done. To check for lock-key.
84	Locked key checking is over. Checking for a memory size mismatch with CMOS RAM data next.
85	The memory size check is done. Displaying a soft error and checking for a password or bypassing Setup next.
86	Password checked. About to do programming before setup.
87	The programming before Setup has completed. Uncompressing the Setup code and executing the AMIBIOS Setup utility next.
88	Returned from CMOS setup program and screen is cleared. About to do programming after setup.
89	The programming after Setup has completed. Displaying the power on Screen message next.
8B	The first screen message has been displayed. The <WAIT...> message is displayed. Performing the PS/2 mouse check and extended BIOS data area allocation check next.
8C	Programming the Setup options next.
8D	Going for hard disk controller reset.
8F	Hard disk controller reset done. Floppy setup to be done next.
91	The floppy drive controller has been configured. Configuring the hard disk drive controller next.
95	Initializing the bus option ROMs from C800 next.
96	Initializing before passing control to the adaptor ROM at C800.
97	Initialization before the C800 adaptor ROM gains control has completed. The adaptor ROM check is next.
98	The adaptor ROM had control and has now returned control to BIOS POST. Performing any required processing after the option ROM returned control.
99	Any initialization required after the option ROM test has completed. Configuring the timer data area and printer base address next.
9A	Return after setting timer and printer base address. Going to set the RS-232 base address.
9B	Returned after setting the RS-232 base address. Performing any required initialization before the Coprocessor test next.
9C	Required initialization before the Coprocessor test is over. Initializing the Coprocessor next.

Code	Description
9D	Coprocessor initialized. Going to do any initialization after Coprocessor test.
9E	Initialization after the Coprocessor test is complete. Checking the extended keyboard, keyboard ID, and Num Lock key next. Issuing the keyboard ID command next.
A2	Displaying any soft errors next.
A3	Soft error display complete. Going to set keyboard typematic rate.
A4	Keyboard typematic rate set. To program memory wait states.
A5	Memory wait state programming is over. Clearing the screen and enabling parity and the NMI next.
A7	NMI and parity enabled. Performing any initialization required before passing control to the adaptor ROM at E000 next.
A8	Initialization before passing control to the adaptor ROM at E000h completed. Passing control to the adaptor ROM at E000h next.
A9	Returned from adaptor ROM at E000h control. Performing any initialization required after the E000 option ROM had control next.
AA	Initialization after E000 option ROM control has completed. Displaying the system configuration next.
AB	Building the multiprocessor table, if necessary.
AC	Uncompressing the DMI data and initializing DMI POST next.
B0	The system configuration is displayed.
B1	Copying any code to specific areas.
00	Code copying to specific areas is done. Passing control to INT 19 h boot loader next.

4.12 Flash BIOS Utility

Utilize AMI Flash BIOS programming utility to update on-board BIOS for the future new BIOS version. Please contact your technical window to get this utility if necessary.

NOTE : Remark or delete any installed Memory Management Utility (such as HIMEM.SYS, EMM386.EXE, QEMM.EXE, ..., etc.) in the CONFIG.SYS files before running Flash programming utility.

CHAPTER 5

Troubleshooting

This chapter provides you a few useful tips to quickly get your 3307555 running with no failure. As basic hardware installation has been addressed in Chapter 3, this chapter will basically focus on system integration issues, in terms of backplane setup, BIOS setting, and OS diagnostics.

5-1 Backplane setup

Backplane

3307555 is a full-sized SBC, and therefore is able to run on any PICMG backplane, active or passive.

ATX power

3307555 is designed to support ATX powering. Please refer to the following instruction to apply ATX power on your 3307555 and backplane.

Step1: Remove the jumper on pin3 and pin4 of CN4 (ATX P/S CONTROL CONNECTOR , 4-pin) connector (see the Figure below). CN4 connector is on the lower-left side of the CN7 (ATX POWER CONNECTOR) on the backplane.

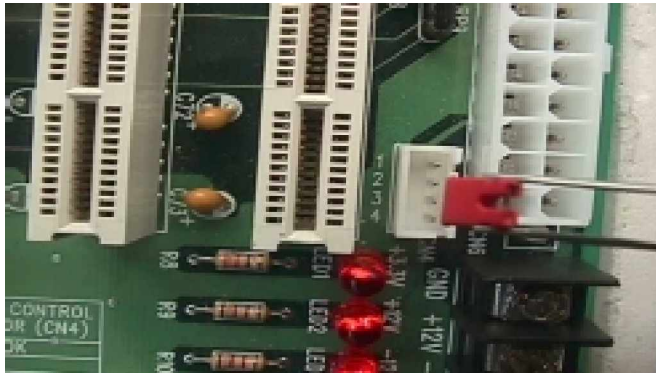

Step2: Connect 20-pin power cable of the ATX POWER with the CN7 (ATX POWER CONNECTOR,20-pin) connector on the backplane. The CN7 is located on the upper-right side of the backplane with white color.

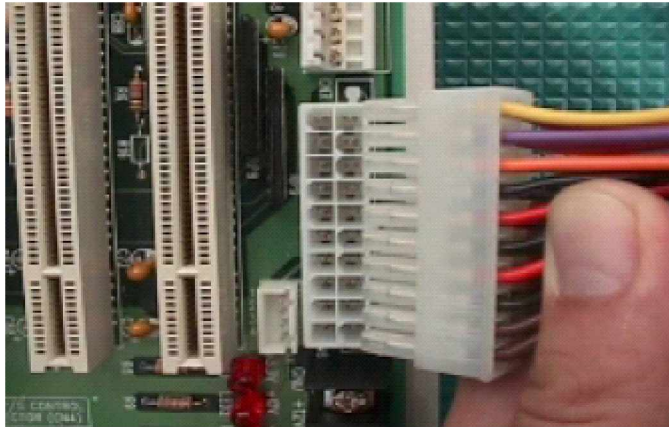

Step3: Use a 4-pin power cable to connect the CN4 (ATX P/S CONTROL CONNECTOR,4-pin) connector on the backplane.

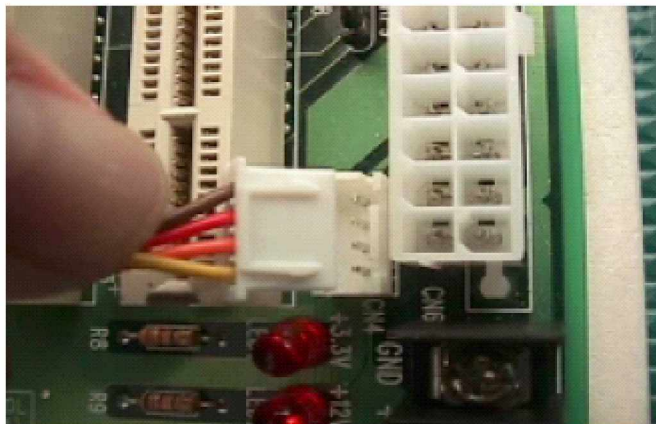

Step4: You can find the J10 JUMPER on the upper-right side of the SBC with white color. You can also see a mark with “J10” besides the J10 connector on the SBC. Connect the other end of the 4-pin power cable with this J10 connector on the SBC.

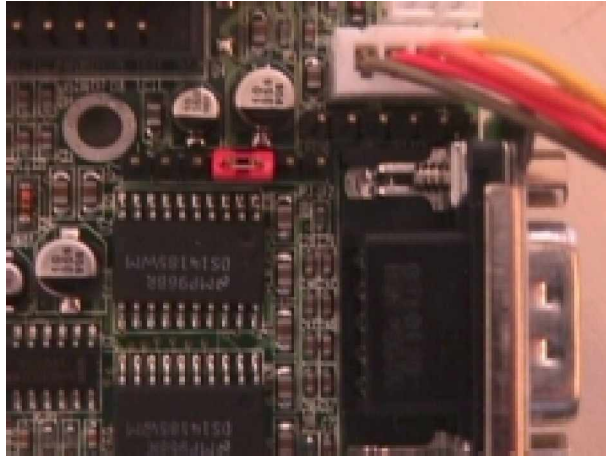

Step5: Connect a 2-pin TOGGLE SWITCH with J12 connector on the SBC.

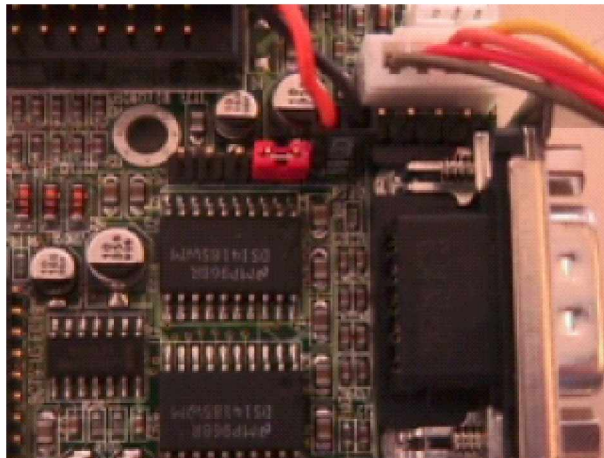

Step6: The figure below is the TOGGLE SWITCH which is used to switch the ATX Power on/off for SBC. Usually the TOGGLE SWITCH is located on the chassis front panel. Press the switch button once will turn power on, and press again to turn it off.

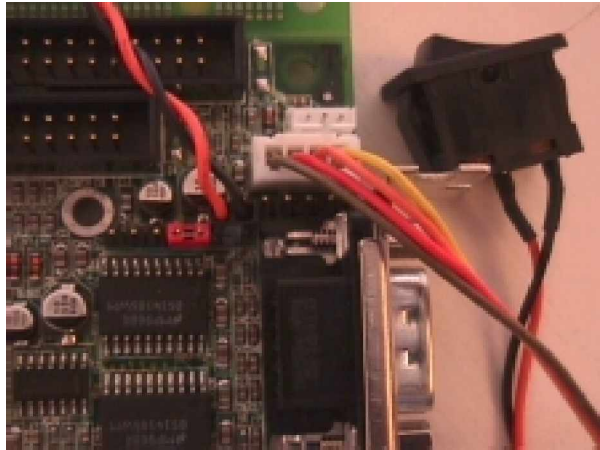

Keyboard

Users may always adopt PS/2 keyboard over the PS/2 keyboard interface, J18, on 3307555. However, it is also fine to adopt a standard keyboard over the standard keyboard connector on backplane, if provided. In this way, users need to adopt a 5-pin keyboard connection cable to line-up external keyboard interface, J24 on 3307555 with the 5-pin keyboard connector on backplane.

5-2 BIOS setting

It is assumed that users have correctly adopted modules and connected all the device cables required before turning on AT power. CPU, CPU fan, CPU fan power cable, 168-pin SDRAM, keyboard, mouse, floppy drive, IDE hard disk, printer, VGA connector, device power cables, ATX accessories or P8/P9 power cable are good examples that deserve attention. With no assurance of properly and correctly accommodating these modules and devices, it is very possible to be accompanied with system failures that result in malfunction of any devices applied.

To make sure that you have a successful first go with your 3307555, it is recommended, when proceeding the boot-up sequence, to hit “DEL” key and enter the BIOS setup menu to tune up a stable BIOS configuration so that you can wake up your system far well.

Loading the default optimal setting

When prompted with the main setup menu, please scroll down to “**Auto Configuration with Optimal Settings**”, press “Enter” and “Y” to load in default optimal BIOS setup. This will force your BIOS setting back to the initial factory configuration. It is recommended to do this so that you can be sure that system is running with the BIOS setting that GAI has highly endorsed. As a matter of fact, users can load in the default BIOS setting any time system appears to be unstable in boot up sequence.

Auto Detect Hard Disks

It is pretty common that users may proceed “**Auto Detect Hard Disks**” to backup the hard drive status in BIOS memory so as to reduce the time spent in boot-up hard disk detection process. However, as BIOS has already kept this information, if another different hard drive is applied without redoing “**Auto Detect Hard Disks**” procedure, system will fail to identify the hard disks that are actually connected. A quick way to fix this problem is to enter the BIOS setup menu and redo “**Auto Detect Hard Disks**” again.

There is also another way to keep away this detour. Please go to “**Standard COMS Setup**” and tune, in the hard disk status, the “**Primary Master**” and “**Primary Slave**” to “**Auto**” with their “**32-bit mode**” being tuned also to “**ON**”. This will force your system to automatically detect the current attached hard disks during each boot up sequence. It is then no longer necessary to “manually” detect the hard disks each time you try the boot up sequence.

Please note that load in default optimal BIOS setting will not change the hard disk detection status back to “**Auto**”. You may find still, even you load in the default BIOS setting, the hard disk detection status remains unchanged.

Additionally, it is also recommended to double check your hard disk or CDROM setting in the event of connecting two IDE devices through one IDE port. One of these two devices need to be configured as slave device to prevent detection failure of IDE devices. There can not be two IDE devices being the master devices at the same time.

Improper disable operation

There are too many occasions where users disable, in BIOS setup, a certain device/feature in one application, but does not enable it before manipulating with another application where the disabled device is needed. Certainly, users fail to detect this device/feature and end up with system failure. Please do check in the BIOS setting that the devices or ports that you need are not disabled.

These include floppy drive, COM1/COM2 ports, parallel port, USB ports, external cache, and on-chip VGA display mode.

It is also very common that users would like to disable a certain device/port to release IRQ resource. A few good examples are

disable COM1 serial port to release IRQ #4
disable COM2 serial port to release IRQ #3
disable parallel port to release IRQ #7
disable PS/2 mouse to release IRQ #12
.....etc.

A quick review of the basic IRQ mapping is given below for your reference.

IRQ #0 : System Counter
IRQ #1 : Keyboard
IRQ #2 : Cascade IRQ
IRQ #3 : COM2
IRQ #4 : COM1
IRQ #5 : Nothing
IRQ #6 : Floppy Disk Controller
IRQ #7 : Printer Port (Parallel Port)
IRQ #8 : CMOS Clock
IRQ #9 : Nothing
IRQ #10 : Nothing
IRQ #11 : Nothing
IRQ #12 : PS/2 mouse
IRQ #13 : Data Processor
IRQ #14 : Primary IDE Controller
IRQ #15 : Secondary IDE Controller

It is then very easy to find out which IRQ resource is ready for you to apply additional peripherals. If IRQ resource is not enough, please disable some devices listed above to release more.

5-3 OS diagnostics

What will be presented here is a brief guide to properly house-in the driver for any Microsoft Windows-95/98/NT device as well as start special function in a specific operating system. For other operating systems, please refer to OS manual/guidebook.

Booting

Users may find quite a lot that Windows-95/98 hangs in loading sequence. Windows logo stays with no progress, or simply no display is given. Please restart your system and hit "F5" when loading the Windows system and enter "Safe mode". Users will always be allowed to enter "Safe mode" with success to remove devices that are not properly running or installed. Please proceed to do so and restart your Windows. Removed devices will be automatically detected again and drivers will be loaded in if drivers have been copied in the system database, or you will be asked to provide driver source for installation.

For Windows-NT 4.0 users, it is always not recommended to change your hardware configuration after your first installation. However, if such change is needed, please note that sometimes Windows-NT 4.0 will stop loading and prompt you with a whole page of error messages. Please note that reinstallation of this NT hard disk is inevitable, but you may then like to backup your data stored in this hard disk and it is almost impossible to switch back this system unless booting up with another hard disk. If this NT hard disk is installed with FAT16 disk format, please boot your up your system with any Windows OS. Thus, you will be able to see this NT hard disk and retrieve any data you have interest. However, if this NT hard disk is installed with NTFS disk format, there is only NTFS that allows you to retrieve this NT hard disk again.

Display setup

By default, any Windows OS starts with 640 x 480 by 16 colors display. Please load in the display driver provided in 3307555 product CDROM to maximize the VGA performance. If you are using a monitor that Windows cannot identify, you will need also to set, in the display setup menu, a system monitor to correctly retrieve display output. For Windows-NT 4.0 users, as 3307555 provides AGP type on-chip display feature, Service Pack 3.0 or above is absolutely required to activate AGP VGA display feature.

Network setup

1. Windows-95/98 users. Please apply an ISA/PCI network card over ISA/PCI slot, start Windows-95/98 and let Window-95/98 to automatically detect your network adapter. Please provide the driver and complete installation.

Restart your windows system is required then, and after you come back to windows, please go to Control Panel -> System -> Device Manager and see if your network adapter has been installed properly. A warning sign will be prompted to show improper installation. Please remove this network device from system setup menu and restart windows to re-detect your network adapter again.

After you are sure that hardware installation is completed, please go to Control Panel -> Network to set up your networking configuration. This includes DNS, IP, Gateway. Appropriate protocols are required to carry your networking activities. Please refer to your system administrator for additional assistance.

2. Windows-NT 4.0 users. Please install your network adapter manually in Control Panel -> Network -> Adapter. Drivers are required at this stage. Proceed "Binding" after you load in the driver. Change to Protocol label and load in the protocols that you have interest (generally, TCP/IP). Configuring IP, gateway and DNS is required for TCP/IP protocol. Proceed again "Binding" after you complete the protocol loading. Restart your system.

There is also situation that your installed network adapter is not working anymore for you, or old network driver stays in the system after you change your network card. Please remove then all the network adapters and protocols from network setup menu and redo the loading of driver and protocols again.

Network setup within Windows-NT 4.0 is not as easy as that within Windows-95/98. Special familiarity and care are required to come out with a successful installation.

Any advice or comments about our products and service, or anything we can help you with please don't hesitate to contact with us. We will do our best to support your products, projects and business.



Address: Global American, Inc.
17 Hampshire Drive
Hudson, NH 03051

Telephone: Toll Free (U.S. Only) 800-833-8999
(603)886-3900

FAX: (603)886-4545

Website: <http://www.globalamericaninc.com>
E-Mail: salesinfo@globalamericaninc.com

