



3307558
INDUSTRIAL GRADE
CPU BOARD
User' s Guide

Table of Contents

0. PREFACE.....	3
0.1 COPYRIGHT NOTICE AND DISCLAIMER	3
0.2 WELCOME TO THE 3307558 CPU BOARD	3
0.3 BEFORE YOU USE THIS GUIDE	3
0.4 RETURNING YOUR BOARD FOR SERVICE	3
0.5 TECHNICAL SUPPORT AND USER COMMENTS	3
0.6 ORGANIZATION	4
0.7 STATIC ELECTRICITY PRECAUTIONS	4
1. OVERVIEW	5
1.1 SPECIFICATION	5
1.2 PACKING LIST	5
1.3 FEATURES	6
1.4 POINT FOR ATTENTION	6
2. SYSTEM CONTROLLER.....	7
2.1 POWERFUL X86 PROCESSOR	7
2.2 64-BIT SDRAM UMA CONTROLLER.....	8
2.3 CRT CONTROLLER	9
2.4 2D GRAPHICS ENGINE	10
2.5 INTERRUPT CONTROLLER.....	10
2.6 DMA CONTROLLER.....	11
2.7 TIMER / COUNTERS	12
2.8 IDE CONTROLLER.....	12
2.9 OPTIONAL 16-BIT LOCAL BUS INTERFACE	12
2.10 ISA MASTER / SLAVE.....	12
2.11 PCI MASTER / SLAVE / ARBITER	13
3. SETTING UP THE SYSTEM	14
3.1 OVERVIEW	14
3.2 SYSTEM SETTING	14
3.2.1 Hard Disk (IDE) Connector	15
3.2.2 FDD Port Connector (CN4).....	16
3.2.3 Ethernet RJ-45 Connector (LAN1).....	17
3.2.4 PS/2 Mouse Connector (CN2 & PS1)	17
3.2.5 PS-ON Header (CN1)	17
3.2.6 Reset Header (J1).....	17
3.2.7 Power Connector (PWR1).....	18
3.2.8 CRT Connector (DB1).....	18
3.2.9 LCD Supported Voltage LCD1 Select (JP1).....	18
3.2.10 LCD Panel Display Connector (LCD1).....	19
3.2.11 LED Header (J8).....	19
3.2.12 PC/104 Connector.....	20
3.2.13 Parallel Port Connector (CN3).....	21
3.2.14 IR Header (J4).....	21
3.2.15 Power External Connector (J11)	21
3.2.16 Speaker External Connector (J10).....	21
3.2.17 COM1, COM2 (DB2, CN5).....	22
3.2.18 Touch Screen Connector (J6 & J7).....	23
3.2.19 D.O.C. Memory Bank Address Select (JP3).....	23
3.2.20 ATX POWER External Bottom Connector (J2).....	24
3.2.21 Ethernet Setup (JP2).....	24
3.3 WATCHDOG TIMER	24
3.3.1 Watchdog Timer Setting.....	25
3.3.2 Watchdog Timer Trigger	25
4. INSTALLATION.....	27
4.1 OVERVIEW	27
4.2 UTILITY DISKETTE	27
4.2.1 Driver Installation	27
5. BIOS CONSOLE.....	28
5.1 BIOS SETUP OVERVIEW	28
5.2 STANDARD CMOS SETUP	30
5.3 ADVANCED CMOS SETUP	31
5.4 ADVANCED CHIPSET SETUP	34
5.5 POWER MANAGEMENT.....	35
5.6 PC/PLUG AND PLAY.....	36
5.7 PERIPHERAL SETUP	37
5.8 AUTO-DETECT HARD DISKS	38

5.9 PASSWORD SETTING	38
5.10 LOAD DEFAULT SE TTING.....	38
5.10.1 Auto Configuration with Optimal Setting.....	38
5.10.2 Auto Configuration with Fail Safe Setting.....	38
5.11 BIOS EXIT	38
5.11.1 Save Settings and Exit.....	39
5.11.2 Exit Without Saving.....	39
5.12 BIOS UPDATE	40

ACKNOWLEDGEMENTS

Global AMI, IBM PC/AT, ALI, Windows 3.1, MS-DOS, are registered trademarks.

All other trademarks and registered trademarks are the property of their respective holders.

0.2 WELCOME TO THE 3307558 CPU BOARD

This guide introduces the 3307558 CPU board.

The information provided in this manual describes about the card functions and features. It also helps you start, set up and operate your 3307558. General system information can also be found in this publication.

0.3 BEFORE YOU USE THIS GUIDE

Please refer to the Chapter 3, "Setting up the System" in this guide, if you have not already installed this 3307558. Check the packing list before you install and make sure the accessories are completely included.

The 3307558 CD provides the newest information about the card. **Please refer to the files of the enclosed utility CD.** It contains the modification, hardware & software information. And it also has updated the product functions that may not be mentioned here.

0.4 RETURNING YOUR BOARD FOR SERVICE

If your board requires any services, contact the distributor or sales representative from whom you purchased the product for service information. If you need to ship your board to us for service, be sure it is packed in a protective carton. We recommend that you keep the original packaging for this purpose.

You can assure efficient servicing for your product by following these guidelines:

1. Include your name, address, daytime telephone and facsimile numbers and E-mail.
2. A description of the system configuration and/or software at the time is malfunction,
3. A brief description of the problem occurred.

0.5 TECHNICAL SUPPORT AND USER COMMENTS

User's comments are always welcome as they assist us in improving the quality of our products and the readability of our publications. They create a very important part of the input used for product enhancement and revision.

We may use and distribute any of the information you provide in anyway appropriate without incurring any obligation. You may, of course, continue to use the information you provide.

If you have any suggestions for improving particular sections or if you find any errors on it, please send your comments to Global American, Inc local sales representative and indicate the manual title and book number.

Internet electronic mail to: WWW.GlobalAmericaninc.com

Check our FAQ sheet for quick fixes to known technical problems.

0.6 ORGANIZATION

This manual covers the following topics (see the Table of Contents for a detailed listing):

- | Chapter 1, "Overview", provides an overview of the system features and packing list.
- | Chapter 2, "System Controller" describes the major structure.
- | Chapter 3, "Setting Up the System", describes how to adjust the jumper, and the connector's settings.
- | Chapter 4, "Installation", describes setup procedures including information on the utility diskette.
- | Chapter 5, "BIOS Console", provides the BIOS options settings.

0.7 STATIC ELECTRICITY PRECAUTIONS

Before removing the board from its anti-static bag, read this section about static electricity precautions.

Static electricity is a constant danger to computer systems. The charge that can build up in your body may be more than sufficient to damage integrated circuits on any PC board. Therefore, it is very important to observe basic precautions whenever you use or handle computer components. Although areas with humid climates are much less prone to static build-up, it is always best to safeguard against accidents that may result in expensive repairs. The following measures should be sufficient to protect your equipment from static discharge:

- Touch a grounded metal object to discharge the static electricity in your body (or ideally, wear a grounded wrist strap).
- When unpacking and handling the board or other system components, place all materials on an anti-static surface.
- Be careful not to touch the components on the board, especially the "golden finger" connectors on the bottom of the board.

1. OVERVIEW

3307558 is a Consumer II /Elite PC-133 CPU Board with Ethernet, DOC, and Compact Flash (option).

This chapter provides an overview of your system features and capabilities. The following topics are covered:

- | Specification
- | Packing List
- | Features
- | Point for attention

1.1 SPECIFICATION

- | CPU: Consumer II/Elite PC-133 BGA.
- | RAM Memory: On board 32 MB SDRAM.
- | SSD: Support one socket for DiskOnChip.
- | Watchdog: Software programmable 1~63sec.
- | VGA Memory: 3307558 -- UMA, shared system memory up to 4MB
Supports CRT interface.
- | 3307558B – Embedded 2MB SDRAM Video memory
Supports CRT interface.
- | VGA Interface: 3307558– CRT-D-SUB 15pin female connector at bracket.
3307558B– CRT-D-SUB 15pin female connector at bracket.
LCD with 2.0mm 44-pin Header connector.
- | Ethernet: RTL8100B chipset, supports **10/100M baseT** with RJ-45 connector built-in LED.
- | Super I/O: Winbond 83977F-A
 - 2 EIDE** (Ultra DMA33)– with one 2.54 mm 40-pin connector and one
2.00 mm 44-pin connector
 - 1 FDC** – with 2.54 mm 34-pin connector.
 - 1 Parallel**– with 2.54 mm 26-pin connector (supports SPP/EPP/ECP mode).
 - 1 RS-232C/RS485** –COM1 Share with 485
 - 1 RS-232C /IrDA/Touch Screen** – with 2.54 mm 10-pin connector
RS-232C is selectable by jumper and use the same connector.
IrDA with 2.54mm 5-pin header.
Touch Screen with 2.0mm 3-pin JST connector.
- | BIOS: Flash BIOS AMI.
- | Keyboard/Mouse: PS/2 compatible 6-pin mini-DIN connector.
- | RTC: Chipset including, Support **ACPI function** with 7 years data retention.
- | Expansion Bus: PC/104.
- | Power Connector: One 4-pin Wafer Connector.
- | Power Req.: +5V-1.4A maximum and 12V –0.01A maximum.
- | PC Board: 6 layers, EMI considered
- | Dimensions: 185 mm x 122 mm (7.3"x4.8")

1.2 PACKING LIST

Some accessories are included with the system. Before 3307558 has been installed, please take a moment to make sure that the following items have been included inside the 3307558 package.

- | The quick setup manual
- | 1 3307558 CPU board
- | 1 Hard disk drive adapter cable for 3.5" HDD
- | 1 Hard disk drive adapter cable for 2.5" HDD
- | 1 Floppy disk drive adapter cable.
- | 1 Parallel port adapter cable & 1 RS-232C interface cable mounted on one bracket
- | 1 PS/2 Y-type cable
- | 1 Software utility CD

1.3 FEATURES

The system provides a number of special features that enhance its reliability, ensure its long-term availability, and improve its expansion capabilities, as well as its hardware structure.

- | Consumer II/Elite PC-133 BGA
- | On board 32 MB SDRAM and one SO-DIMM socket.
- | Supports DOC Flash Disk.
- | 10/100M-Base Ethernet.
- | Compact Flash (AR-B9462A) optional.
- | AMI BIOS.
- | Power Req.: +5V-1.4A maximum and 12V -0.01A maximum.
- | Dimensions: 185 mm x 122 mm (7.3"x4.8").

1.4 POINT FOR ATTENTION

The 3307558 CPU is a consumer II with C4 as a version that included some bugs on it. The effect is the use of floppy in WIN95 would be unable. The bug can be revised in CPU with C5 as a version. But according to ST as the original manufacturer, C5 just can normally be produced at least in October. The bug still exists so it is better to use the C4. Therefore, we decided to adopt no support as our temporary strategy.

In 3307558B section, we have to install WIN 95, and then set up the Floppy driver as the additional step in order to drive the 3007558 Floppy devices properly.

2. SYSTEM CONTROLLER

This chapter describes the main structure of the 3307558 CPU board. The following topics are covered:

- | Powerful x86 Processor
- | 64-Bit SDRAM UMA Controller
- | CRT Controller
- | 2D Graphics Engine
- | Interrupt Controller
- | DMA Controller
- | Timer/Counters
- | IDE Controller
- | Optional 16-Bit Local Bus Interface
- | ISA Master/Slave
- | PCI Master/Slave/Arbiter

2.1 POWERFUL X86 PROCESSOR

The 3307558 uses the Consumer II/Elite PC-133 BGA, it is an advanced 64-bit x86 processor block compatible processor offering high performance, fully accelerated 2D graphics, a 64-synchronous DRAM controller, all on a single chip. It includes a 64-bit SDRAM controller, a high speed PCI local-bus controller and Industry standard PC chip set functions (Interrupt controller, DMA Controller, Interval timer and ISA BUS).

- | Fully static 32-bit five-stage pipeline, x86 processor fully PC compatible.
- | Can access up to 4 GB of external memory.
- | 8 Kbyte unified instruction and data cache with write back and write through capability.
- | Parallel processing integral floating-point unit, with automatic power down.
- | Runs up to 100 MHz (x1) or 133 MHz (x2).
- | Fully static design for dynamic clock control.
- | Low power and system management modes.
- | Optimized design for 2.5 V operations.

2.2 64-BIT SDRAM UMA CONTROLLER

- | 64-bit data bus.
- | Up to 100 MHz SDRAM clock speed.
- | Integrated system memory, graphic frame memory and video frame memory.
- | Supports 2MB up to 128 MB system memory
- | Supports 16-, 64-, and 128-Mbit SDRAMs.
- | Supports 8, 16, 32, 64, and 128 MB DIMMs.
- | Supports buffered, non-buffered, and registered DIMMs.
- | Four-line write buffers for CPU to SDRAM and PCI to SDRAM cycles.
- | Four-line read prefetch buffers for PCI masters.
- | Programmable latency
- | Programmable timing for SDRAM parameters.
- | Supports -8, -10, -12, -13, -15 memory parts.
- | Supports memory hole between 1 MB and 8 MB for PCI/ISA busses.

The SDRAM controller only supports 64 bit wide Memory Banks.

Four Memory Banks (if DIMMs are used; Single sided or two doubled-sided DIMMs) are supported in the following configurations.

Memory Bank size	Number	Organization	Device Size
1Mx64	4	1Mx16	16Mbits
2Mx64	8	2Mx8	
4Mx64	16	4Mx4	
4Mx64	4	2Mx16x2	64Mbits
8Mx64	8	4Mx8x2	
16xM64	16	8Nx4x2	
4Mx64	4	1Mx16x4	
8Mx64	8	2Mx8x4	
32Mx64	16	4Mx4x4	128Mbits
16Mx64	8	2Mx16x2	
32Mx64	16	4Mx8x4	

Memory configurations

The SDRAM Controller supports buffered or unbuffered SDRAM but not EDO or FPM modes. SDRAMs must support Full Page Mode Type access.

The STPC Memory Controller provides various programmable SDRAM parameters to allow the SDRAM interface to be optimized for different processor bus speeds SDRAM grades and CAS Latency

This chapter defines the STPC Consumer-II Strap Options and their location. Some strap options are left programmable for future versions of silicon.

Strap Options

Signal	Designation	Actual Settings ¹	Set to '0'	Set to '1'
MD1	Reserved	Pull-up	-	-
MD2	HCLK PLL Speed	User defined	see Section 3.1.4. bit 6	
MD3		User defined	see Section 3.1.4. bit 7	
MD4	PCICLK0 Division	User defined	see Section 3.1.3. bit 1	
MD5	MCLK/HCLK Sync (see Section 3.1.1.)	User defined	Async	Sync
MD6	PCICLK0 frequency	User defined	see Section 3.1.1. bit 6	
MD7	Reserved	Pull-down	-	-
MD10	Reserved	Pull-down	-	-
MD11	Reserved	Pull-down	-	-
MD14	Reserved	Pull-up	-	-
MD16	Reserved	Pull-up	-	-
MD17	PCI_CLK0 Divisor	User defined	see Section 3.1.3. bit 1	
MD18	Reserved	Pull-up	-	-
MD19	Reserved	Pull-up	-	-
MD20	DCLK Pad Direction	User defined	Input	Output
MD21	Reserved	Pull-up	-	-
MD22	Reserved	Pull-up	-	-
MD23	Reserved	Pull-up	-	-
MD24	HCLK PLL Speed	User defined	see Section 3.1.4. bit 3	
MD25		User defined	see Section 3.1.4. bit 4	
MD26		User defined	see Section 3.1.4. bit 5	
MD27	Reserved	Pull-down	-	-
MD28	Reserved	Pull-down	-	-
MD29	Reserved	Pull-down	-	-
MD30	Reserved	Pull-down	-	-
MD40	CPU Mode (see Section 3.1.3.)	User defined	X1	X2
MD41	Reserved	Pull-down	-	-
MD42	Reserved	Pull-up	-	-
MD43	Reserved	Pull-down	-	-
MD44	Bus select (see Section 3.1.1.)	User defined	ISA	Local Bus
MD45	Reserved	Pull-down	-	-
MD46	Reserved	Pull-up	-	-
MD47	Reserved	Pull-down	-	-
MD48	Reserved	Pull-up	-	-
TC	Reserved	Pull-up	-	-
DACK_ENC[2:0]	Reserved	Pull-up	-	-

Note¹: Where a strap is represented by a 'Pull up' or 'Pull down', these have to be adhered to. If it is represented as a '-' it can be left unconnected. Where 'User defined', the strap is set by the user.

2.3 CRT CONTROLLER

- | Integrated 135 MHz triple RAMDAC allowing for 1280 x 1024 x 75 Hz displays.
- | Requires external frequency synthesizer and reference sources.
- | 8-bit, 16-bit, 24-bit pixels.
- | Interlaced or non-interlaced output.
- | Requires no external frequency synthesizer.
- | Requires only external reference source.

2.4 2D GRAPHICS ENGINE

- | 64-bit windows accelerator.
- | Backward compatibility to SVGA standards.
- | Hardware acceleration for text, bitblts, transparent blts and fills
- | Up to 64 x 64 graphics hardware cursor.
- | Up to 4MB long linear frame buffer.
- | 8-, 16-, 24-and 32-bit pixels.
- | Drivers available for various OSes.

2.5 INTERRUPT CONTROLLER

Most of the IPC signals are multiplexed: Interrupt inputs, DMA Request inputs, DMA Acknowledge outputs. The figure below describes a complete implementation of the IRQ [15:0] time multiplexing. When an interrupt line is used internally, the corresponding input can be grounded. In most of the embedded designs, only few interrupts lines are necessary and the glue logic can be simplified.

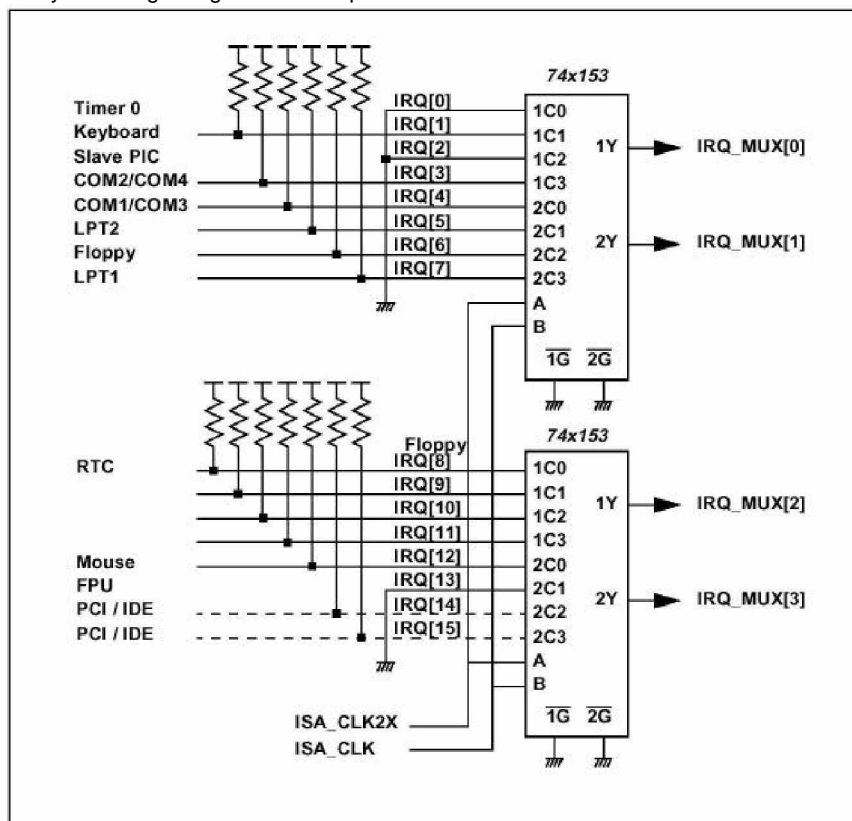

Typical IRQ multiplexing

When the interface is integrated into the STPC, the corresponding interrupt line can be grounded as it is connected internally.

For example, if the integrated IDE controller is activated, the IRQ [14] and IRQ [15] inputs can be grounded.

2.6 DMA CONTROLLER

- | **DMA channel**
- | 2X8237/AT compatible 7-channel DMA controller.
- | 2X8259/AT compatible interrupt Controller.
16 interrupt inputs – ISA and PCI.
- | Three 8254 compatible Timer/Counters.
- | Co-processor error support logic.

The figure below describes a complete implementation of the external glue logic for DMA Request time-multiplexing and DMA Acknowledge demultiplexing. Like for the interrupt lines, this logic can be simplified when only few DMA channels are used in the application. This glue logic is not needed in Local bus mode and it does not support DMA transfers.

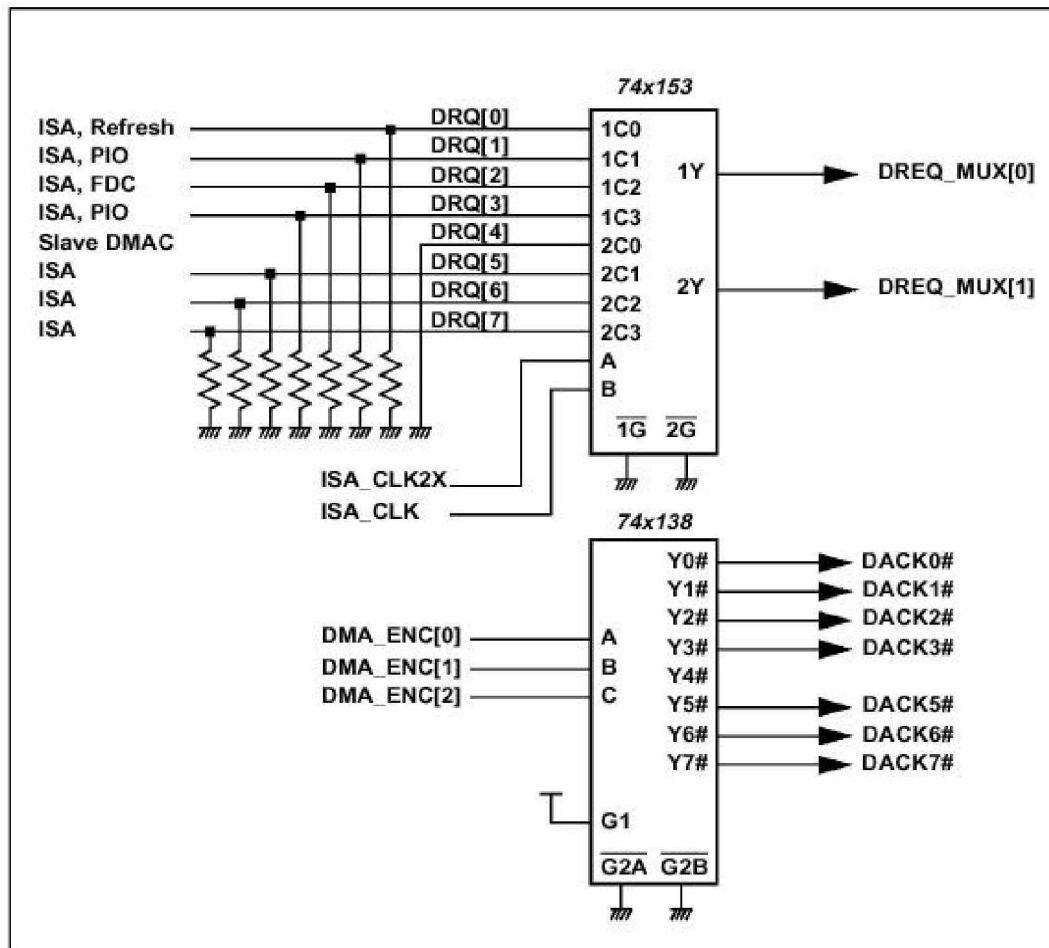

Typical DMA multiplexing and demultiplexing

2.7 TIMER / COUNTERS

- | System Activity Detection.
- | Three power down timers.
- | Doze timer for detecting lack of system activity for short durations.
- | Stand-by timer for detecting lack of system activity for medium durations.
- | Suspend timer for detecting lack of system activity for long durations.
- | Housekeeping activity detection.
- | Housekeeping timer to cope with short bursts of house keeping activity while dozing or in stand-by state.

2.8 IDE CONROLLER

- | Supports PIO.
- | Transfer Rates to 22 Mbytes/sec.
- | Supports up to 4 IDE devices.
- | Concurrent channel operation (PIO modes) –
4 x 32-Bit Buffer FIFOs per channel.
- | Support for PIO mode 3 & 4.
- | Individual drive timing for all four IDE devices.
- | Supports both legacy & native IDE modes.
- | Supports hard drive larger than 528MB.
- | Support for CD-ROM and tape peripherals.
- | Backward compatibility with IDE (ATA-1).
- | Drivers for Windows and other Operating Systems.

2.9 OPTIONAL 16-BIT LOCAL BUS INTERFACE

- | Multiplexed with ISA/DMA interface.
- | Low latency asynchronous bus.
- | 22-bit address bus.
- | 16-bit data bus with word steering capability. |
Programmable timing (Host clock granularity).
- | Two Programmable Flash Chip Select.
- | Four Programmable I/O Chip Select.
- | Supports 32-bit Flash burst.
- | Two-level hardware key protection for Flash boot block protection.
- | Supports two banks of 16MB flash devices with boot block shadowed to 0x000F0000.

2.10 ISA MASTER / SLAVE

- | Generates the ISA clock from either 14.318 MHz oscillator clock or PCI clock.
- | Supports programmable extra wait state for ISA cycles.
- | Supports I/O recovery time for back-to-back I/O cycles.
- | Fast Gate A20 and Fast reset.
- | Supports this single ROM that C, D, or E.
Blocks shares with F block BIOS ROM.
- | Supports flash ROM.
- | Supports ISA hidden refresh.
- | Buffered DMA & ISA master cycles to reduce bandwidth utilization of the PCI and Host bus.

2.11 PCI MASTER / SLAVE / ARBITER

- | Fully compliant with PCI 2.1 specification.
- | Integrated PCI arbitration interface. Up to 3 masters can connect directly. External PAL allows for greater than 3 masters.
- | Translation of PCI cycles to ISA bus.
- | Translation of ISA master initiated cycle to PCI I
- | Support for burst read/write from PCI master. I
- | PCI clock is 1/2, 1/3 or 1/4 CPU bus clock.

3. SETTING UP THE SYSTEM

This section describes pin assignments of on board connector and jumper settings.

- I Overview
- I System Setting

3.1 OVERVIEW

3307558 is a Pentium Grade CPU Board, which supports Ethernet, DOC, SSD, and Compact Flash Functions. This section provides the hardware's jumper settings, the connectors' locations, and the pin assignments.

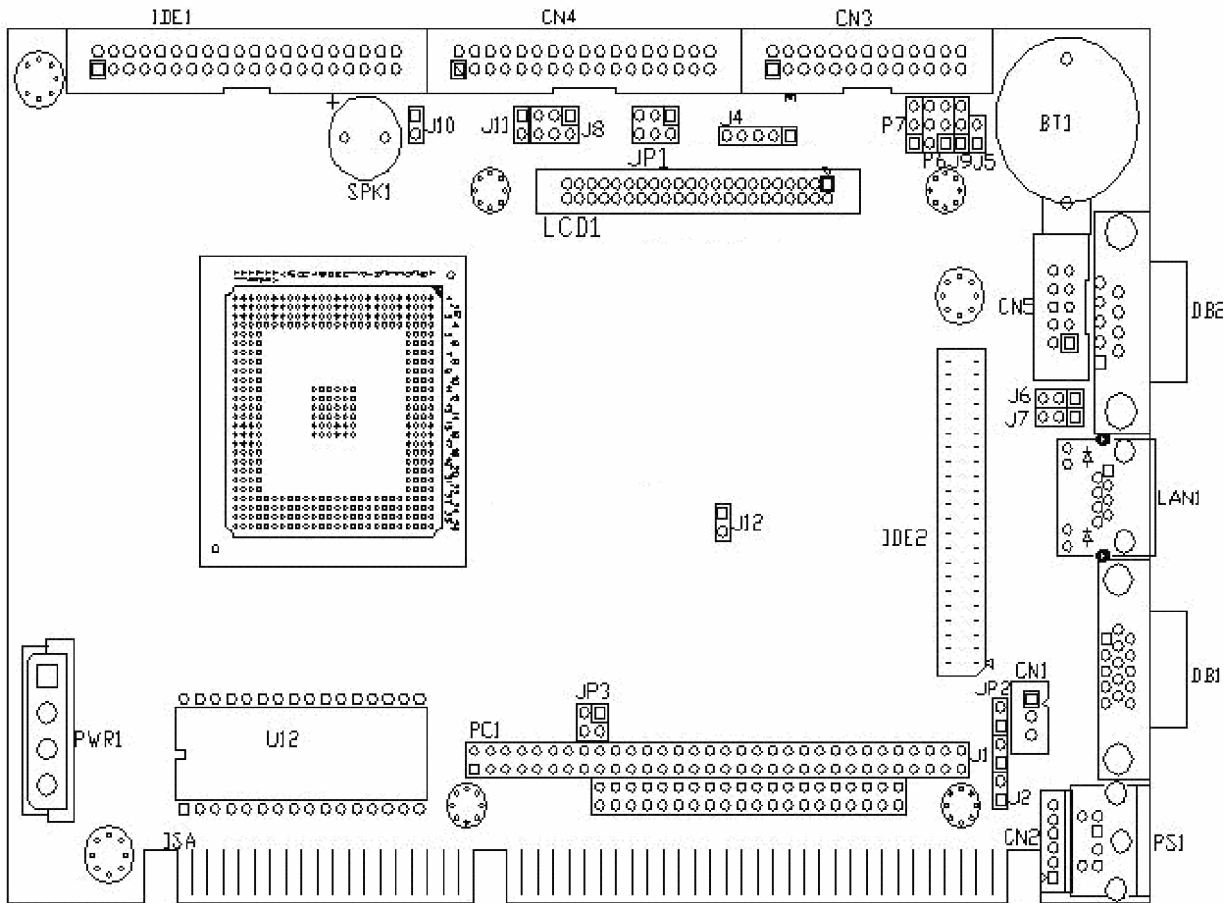

External System Location

3.2 SYSTEM SETTING

Jumper pins allow you to set specific system parameters. Set them by changing the pin location of jumper blocks. (A jumper block is a small plastic-encased conductor that slips over the pins.) To change a jumper setting, remove the jumper from its current location with your fingers or small needle-nosed pliers. Place the jumper over the two pins designated for the desired setting. Press the jumper evenly onto the pins. Be careful not to bend the pins.

CAUTION: Do not touch any electronic components unless you are safely grounded. Wear a grounded wrist strap or touch an exposed metal part of the system unit chassis. The static discharges from your fingers can permanently damage electronic components.

3.2.1 Hard Disk (IDE) Connector

(1) 40-Pin Hard Disk (IDE) Connector (IDE1)

A 40-pin header type connector (IDE1) is provided to interface with up to two embedded hard disk drives (IDE AT bus). This interface, through a 40-pin cable, allows the user to connect up to two drives in a "daisy chain" fashion. To enable or disable the hard disk controller, please use the BIOS Setup program, which is explained further in chapter 5. The following table illustrates the pin assignments of IDE1.

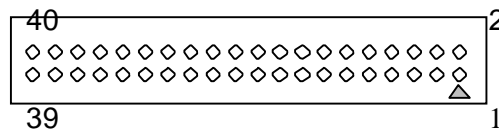

Pin	Signal	Pin	Signal
1	-RESET	2	GROUND
3	DATA 7	4	DATA 8
5	DATA 6	6	DATA 9
7	DATA 5	8	DATA 10
9	DATA 4	10	DATA 11
11	DATA 3	12	DATA 12
13	DATA 2	14	DATA 13
15	DATA 1	16	DATA 14
17	DATA 0	18	DATA 15
19	GROUND	20	NOT USED
21	IDEDREQ	22	GROUND
23	-IOW A	24	GROUND
25	-IOR A	26	GROUND
27	IDEIORDYA	28	GROUND
29	-DACKA	30	GROUND
31	AINT	32	GROUND
33	SA 1	34	Not Used
35	SA 0	36	SA 2
37	CS 0	38	CS 1
39	HD LED A	40	GROUND

Hard Disk (IDE1) Connector

(2) 44-Pin Hard Disk (IDE) Connector (IDE2)

3307558 also provides 44-pin connector (IDE2) interface to connect with the hard disk device. Furthermore, user could also apply (option) to connect with Compact Flash storage device.

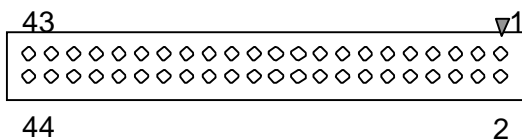

Pin	Signal	Pin	Signal
1	-RESET	2	GROUND
3	DATA 7	4	DATA 8
5	DATA 6	6	DATA 9
7	DATA 5	8	DATA 10
9	DATA 4	10	DATA 11
11	DATA 3	12	DATA 12
13	DATA 2	14	DATA 13
15	DATA 1	16	DATA 14
17	DATA 0	18	DATA 15
19	GROUND	20	NOT USED
21	IDEDREQ	22	GROUND
23	-IOW A	24	GROUND
25	-IOR A	26	GROUND
27	IDEIORDYA	28	GROUND
29	-DACKA	30	GROUND
31	AINT	32	GROUND
33	SA 1	34	Not Used
35	SA 0	36	SA 2
37	CS 0	38	CS 1
39	HD LED A	40	GROUND
41	VCC	42	VCC
43	GROUND	44	Not Used

Hard Disk (IDE2) Connector

3.2.2 FDD Port Connector (CN4)

The 3307558 provides a 34-pin header type connector for supporting up to two floppy disk drives. To enable or disable the floppy disk controller, please use the BIOS Setup program.

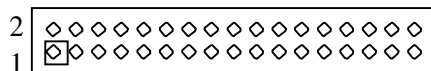

Figure 0-1 CN4: FDD Port connector

Pin	Signal	Pin	Signal
1-33(odd)	GROUND	18	DIRECTION
2	DRVEN 0	20	-STEP OUTPUT PULSE
4	NOT USED	22	-WRITE DATA
6	DRVEN 1	24	-WRITE GATE
8	-INDEX	26	-TRACK 0
10	-MOTOR ENABLE 0	28	-WRITE PROTECT
12	-DRIVE SELECT 1	30	-READ DATA
14	-DRIVE SELECT 0	32	-SIDE 1 SELECT
16	-MOTOR ENABLE 1	34	DISK CHANGE

Table 0-1 FDD Pin Assignment

3.2.3 Ethernet RJ-45 Connector (LAN1)

The LAN1 RJ-45&LED headers are the standard network headers. The following table is the pin assignment.

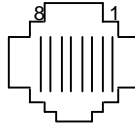

PIN (LAN1)	FUNCTION
1	TPTX+
2	TPTX -
3	TPRX+
4	Not Used
5	Not Used
6	TPRX -
7	Not Used
8	Not Used

RJ-45 Pin Assignment

3.2.4 PS/2 Mouse Connector (CN2 & PS1)

To use the PS/2 interface, an adapter cable has to be connected to the CN2 (6-pin header type) connector. This adapter cable is mounted on a bracket and is included in your 3307558 package. The connector for the PS/2 KB/mouse is a Mini-DIN 6-pin connector. Pin assignments for the PS/2 port connector are as follows:

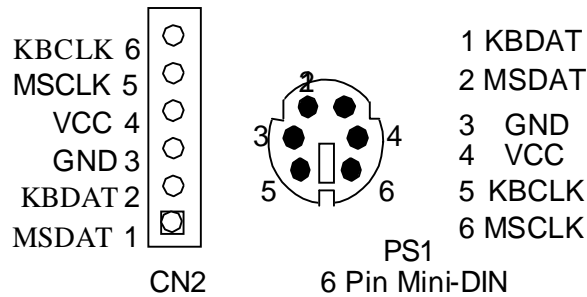
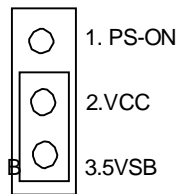

Figure 0-2 CN2 & PS1: PS/2 Mouse Connector

3.2.5 PS-ON Header (CN1)



CN1

- n When AT power supplier is applied; jumper 2&3 should be tied together. (Factory preset)
- n When ATX power supplier is applied, pin1&pin 3 should be connect to proper location of ATX power supplier.

3.2.6 Reset Header (J1)

The J1 is a reset switch. Shorting these two pins will reset the system.

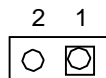

J1

3.2.7 Power Connector (PWR1)

The PWR1 is a 4-pin power connector.

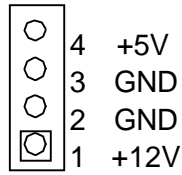

PWR1

PWR1: 4-Pin Power Connector

3.2.8 CRT Connector (DB1)

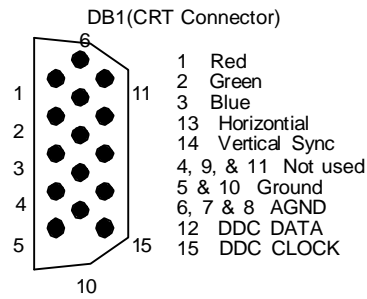

DB1: CRT Connector

3.2.9 LCD Supported Voltage LCD1 Select (JP1)

(Only for 3307558B)

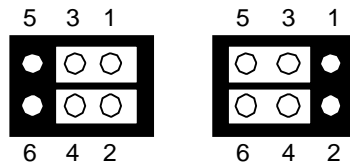

3.3V (Factory Preset)

5V

Figure 0-3 JP1: LCD Supported Voltage LCD1 Select

3.2.10 LCD Panel Display Connector (LCD1)

Attach a display panel connector to this 44-pin connector with pin assignments as shown below:

(Only for 3307558B)

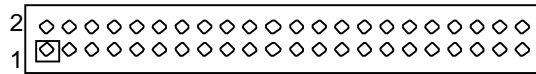

Figure 0-4 LCD1: LCD Display Connector

Pin	Signal	Pin	Signal
1	GND	2	SHFCLK
3	GND	4	LP
5	FLM	6	GND
7	B0	8	B1
9	B2	10	B3
11	B4	12	B5
13	GND	14	B6
15	B7	16	G0
17	G1	18	G2
19	G3	20	GND
21	G4	22	G5
23	G5	24	G6
25	G7	26	R1
27	GND	28	R2
29	R3	30	R4
31	R5	32	R6
33	R7	34	GND
35	VCC	36	VCC
37	+12V	38	+12V
39	GND	40	GND
41	DE	42	ENBLK
43	GND	44	VEE

Table 0-2 LCD Display Pin Assignment

- n The resolution can support CRT on 640*480
800*600
1024*768
1280*1024
- n The resolution can support LCD on 640*480
800*600
1024*768

3.2.11 LED Header (J8)

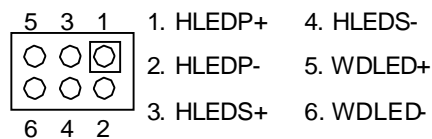

HLEDP: External LED connector for primary IDE channel. HLEDS:
External LED connector for secondary IDE channel. WDLED:
External LED connector for Watchdog status indication.

3.2.12 PC/104 Connector

(1) 64-Pin PC/104 Connector Bus A & B (PC1A)

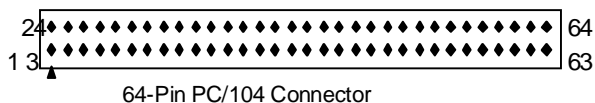
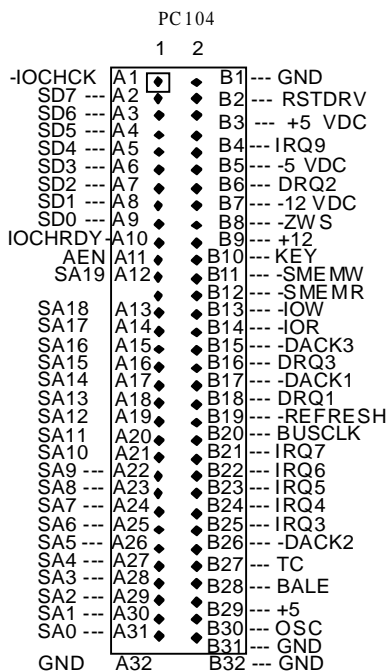

Figure PC1A: 64-Pin PC/104 Connector Bus A & B



(2) 40-Pin PC/104 Connector Bus C & D (PC1B)

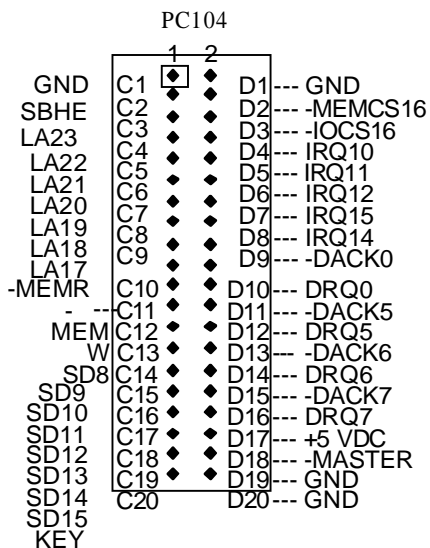
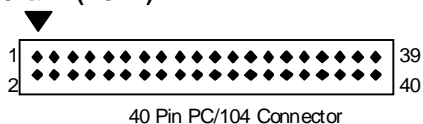
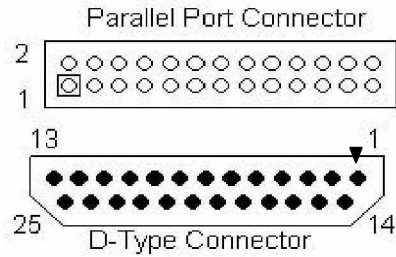

Figure PC1B: 40-Pin PC/104 Connector Bus C & D

3.2.13 Parallel Port Connector (CN3)

The connector for the parallel port is a 26 pins female connector.



PN	Signal	PN	Signal
1	-Strobe	14	-Auto Form Feed
2	Data 0	15	-Error
3	Data 1	16	-Initialize
4	Data 2	17	-Printer Select In
5	Data 3	18	Ground
6	Data 4	19	Ground
7	Data 5	20	Ground
8	Data 6	21	Ground
9	Data 7	22	Ground
10	-Acknowledge	23	Ground
11	Busy	24	Ground
12	Paper	25	Ground
13	Printer Select	26	Not Used

Parallel Port Pin Assignments

3.2.14 IR. Header (J4)

The Infra-red Header pin assignment is as follows:

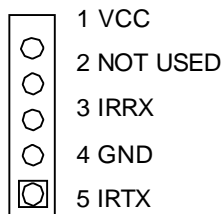

3.2.15 Power External Connector (J11)

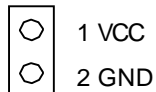

3.2.16 Speaker External Connector (J10)

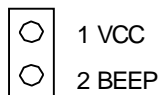

3.2.17 COM1, COM2 (DB2, CN5)

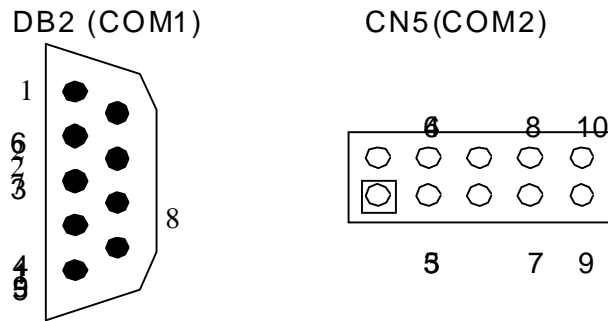

Figure 0-5 DB2 & CN5: RS-232 Connector

DB2	CN5	Signal	DB2	CN5	Signal
1	1	/DCD	8	6	/CTS
6	2	/DSR	4	7	/DTR
2	3	RXD	9	8	/RI
7	4	/RTS	5	9	GND
3	5	TXD	--	10	GND

Table 0-3 RS-232 Connector Pin Assignment

(1) RS-232/RS-485 Select for COM1 (P6 & P7)

The P6&P7 jumper is used to choose between the use of the on-board RS-232 or RS-485 for the DB2 – COM1.

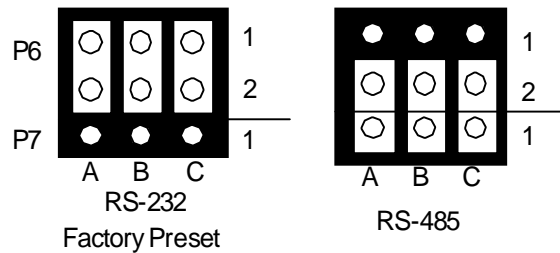
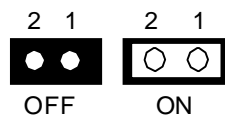

Figure 0-6 P6 & P7: RS-232/RS-485 Select for COM1

(2) RS-485 Terminator Select (J5)

When there is only one line the setting should be left off (please take off the jumper), but if you are using multiple blocks on a single line this should be set to "ON" (place a jumper) in order to properly terminate the connection for better transmission of data



Factory Preset

Figure 0-7 J5: RS-485 Terminator Select

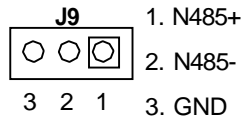
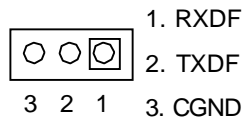
(3) RS-485 Header (J9)**3.2.18 Touch Screen Connector (J6 & J7)****Figure 0-8 J6&J7: Touch Screen Connector****3.2.19 D.O.C. Memory Bank Address Select (JP3)**

This section provides the information about how to use the D.O.C. (Disk On Chip). It divided into two parts: hardware setting and software configuration.

Step 1: Use JP3 to select the correct D.O.C. memory bank address.

Step 2: Insert programmed Disk On Chip into sockets U12 setting as DOC.

Step 3: Line up and insert the AR-B1479A and 3307558B card into slot of your computer.



Factory Preset

Figure 0-9 JP3: D.O.C. Memory Address Select

(Only for 7558A)

JP3	Address	Note
1-2		
3-4	D200:0000	
3-4	CC00:0000	
1-2	C800:0000	Factory Preset
X	D000:0000	

Table 0-4 D.O.C. Memory Address

(Only for 7558B)

JP3	Address	Note
1-2		
3-4	D000:0000	
3-4	D200:0000	
1-2	D400:0000	Factory Preset
X	D600:0000	

3.2.20 ATX POWER External Bottom Connector (J2)

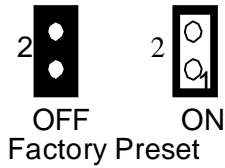
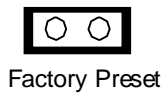

Figure 0-10 J2: External Bottom Connector for ATX power

3.2.21 Ethernet Setup (JP2)

In here not install is called Enable. If it enable, it can pass through Ethernet. And when it disable, it can't pass through Ethernet.



3.2.22 IRQ12 FOR EXPANSION CARDS (J12)

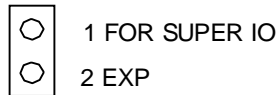

3.3 WATCHDOG TIMER

This section describes the use of Watchdog Timer, including disable, enable, and trigger. AR-B1479 is equipped with a programmable time-out period watchdog timer that occupies I/O port 214H. Users can use simple program to enable the watchdog timer. Once you enable the watchdog timer, the program should trigger it every time before it times out. Watchdog Timer will generate a response (system or IRQ) due to system fails to trigger or disable watchdog timer before preset timer, times out.

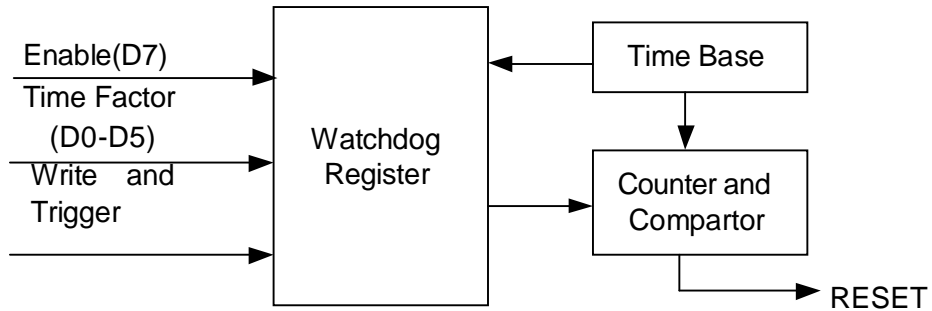

Watchdog Block Diagram

3.3.1 Watchdog Timer Setting

The watchdog timer is a circuit that maybe be used from your program software to detect crash or hang up. The Watchdog timer is automatically disabled after reset. Once you enabled the watchdog timer, your program should trigger the watchdog timer every time before it times out. After you trigger the watchdog timer, the timer will be set to zero and start to count again. If your program fails to trigger the watchdog timer before times out, it will generate a reset pulse to reset the system or trigger the IRQ 9 signal in order to tell your system that the watchdog time is out.

Please refer to the following table in order to properly program Watchdog function

	D7	D6	D5 D4 D3 D2 D1 D0
1	Enable	Reset	Time period
0	Disable	IRQ 9	

Users could test watchdog function under 'Debug' program as follows:

```
C:>debug
I   O 443 CFH
    Generally, watchdog function would
    reset system after 15 seconds
I   O 443 40H
    Disable watchdog function
```

```
C:>debug
I   O 443 88H
    Generally, watchdog function would
    generate IRQ 9 after 8 seconds
I   O 443 40H
    Disable watchdog function
```

3.3.2 Watchdog Timer Trigger

After you enable the watchdog timer, your program must write the same factor as triggering to the watchdog timer at least once during every time-out period. You can change the time-out period by writing another timer factor to the watchdog register at any time, and you must trigger the watchdog during every new time-out period in next trigger.

```
C:>debug
|   O 443 88H
|   Generally, watchdog function would
|   generate IRQ 9 after 8 seconds
|   O 443 83H
|       Disable last watchdog function.
|       Watchdog function would
|       Generate IRQ 9 after 3 seconds.
```

```
C:>debug
|   O 443 CFH
|   Generally, watchdog function would
|   reset system after 15 seconds
|   O 443 C3H
|       Disable last watchdog function.
|       Watchdog function would reset
|       system after 3 seconds.
```

4. INSTALLATION

This chapter describes the installation procedure. The following topics are covered:

- I Overview
- I Utility Diskettes

4.1 OVERVIEW

This chapter provides information for you to set up a working system based on the 3307558 CPU board. Please carefully read the details of the CPU board's hardware descriptions before installation. Pay special attention to the jumper settings, switch settings and cable connections.

Follow steps listed below for proper installation:

- Step 1:** Read the CPU board's hardware description in this manual.
- Step 2:** Set jumpers.
- Step 3:** Make sure that the power supply connected to your AR-B1479 CPU board is turned off.
- Step 4:** Connect all necessary cables. Make sure that the HDD; serial and parallel cables are connected to pin 1 of the related connector (not upside down).
- Step 5:** Connect the hard disk flat cables from the CPU board to the drives. Connect a power source to drive.
- Step 6:** Plug the keyboard into the keyboard connector.
- Step 7:** Turn on the power.
- Step 8:** Configure your system with the BIOS Setup program (section 5) then re-boot your system.
- Step 9:** If the CPU board does not work, turn off the power and read the hardware description carefully again.
- Step 10:** If the CPU board still does not perform properly, return the board to your dealer for immediate service.

4.2 UTILITY DISKETTE

The 3307558 provides a piece of which contains necessary drivers and utility for installing AR_B1479.

4.2.1 Driver Installation

Generally, the CD that comes with 3307558 should be able to carry out 'Auto run' function, please follows the instruction displayed on the screen to install drives. In case, if the 'Auto run' function is fail, please execute 'Setup.exe' program under root directory of the CD.

5. BIOS CONSOLE

This chapter describes the 3307558 BIOS menu displays and explains how to perform common tasks needed to get up and running, and presents detailed explanations of the elements found in each of the BIOS menus. The following topics are covered:

- | BIOS Setup Overview |
- Standard CMOS Setup |
- Advanced CMOS Setup
- | Advanced Chipset Setup
- | Power Management
- | PCI/Plug and Play
- | Peripheral Setup
- | Auto-Detect Hard Disks
- | Password Setting
- | Load Default Setting
- | BIOS Exit

5.1 BIOS SETUP OVERVIEW

The BIOS is a program used to initialize and set up the I/O system of the computer, which includes the ISA bus and connected devices such as the video display, diskette drive, and the keyboard.

The BIOS provides a menu-based interface to the console subsystem. The console subsystem contains special software, called firmware that interacts directly with the hardware components and facilitates interaction between the system hardware and the operating system.

The BIOS default values ensure that the system will function at its normal capability. In the worst situation the user may have corrupted the original settings set by the manufacturer.

After the computer is turned on, the BIOS will perform diagnostics on the system and display the size of the memory that is being tested. Press the [Del] key to enter the BIOS Setup program, and then the main menu will show on the screen.

The BIOS Setup main menu includes some options. Use the [Up/Down] arrow key to highlight the option that you wish to modify, and then press the [Enter] key to select the option and configure the functions.

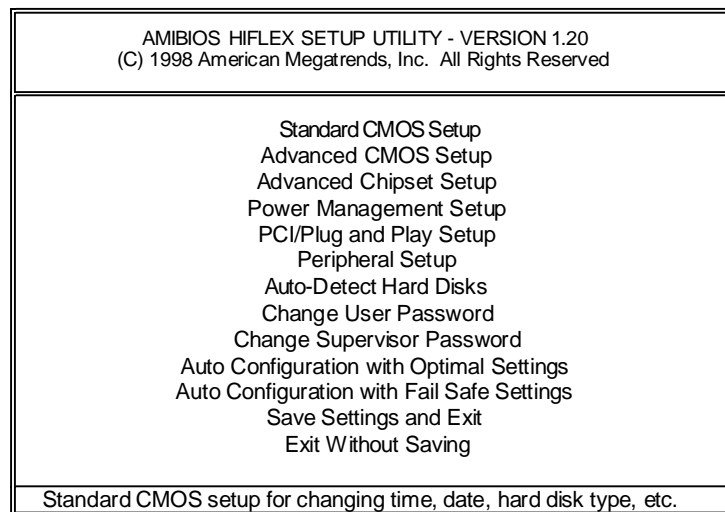

Figure 5-1 BIOS: Setup Main Menu

CAUTION: 1. 3307558 BIOS the factory-default setting is used to the <Auto Configuration with Optimal Settings> Global recommends using the BIOS default setting, unless you are very familiar with the setting function, or you can contact the technical support engineer.

2. If the BIOS settings are lost, the CMOS will detect the <Auto Configuration with Fail Safe Settings> to boot the operation system, this option will reduce the performance of the system. Global recommends choosing the <Auto Configuration with Optimal Setting> in the main menu. This option gives best-case values that should optimize system performance.
3. The BIOS settings are described in detail in this section.

5.2 STANDARD CMOS SETUP

The <Standard CMOS Setup> option allows you to record some basic system hardware configuration and set the system clock and error handling. If the CPU board is already installed in a working system, you will not need to select this option anymore.

AMIBIOS SETUP - STANDARD CMOS SETUP									
(C) 1998 American Megatrends, Inc. All Rights Reserved									
Date (mm/dd/yyyy): Tue Jun 02, 1998					640KB				
Time (hh/mm/ss): 13:39:30					63MB				
Floppy Drive A: 1.44MB 3 1/2									
Floppy Drive B: Not Installed									
32Bit					LBA Blk PIO				
Type	Size	CylIn	Head	Wpcom	Sec	Mode	Mode	Mode	Mode
Pri Master : Auto						Off	Off	Auto	Off
Pri Slave : Auto						Off	Off	Auto	
Off									
Boot Sector Virus Protection Disabled									
Month: Jan - Dec					ESC: Exit F1: Sel				
Day: 01 - 31					PgUp/PgDn: Modify				
Year: 1901 - 2099					F2/F3: Color				

Figure 0-4 BIOS: Standard CMOS Setup

Date & Time Setup

Highlight the <Date> field and then press the [Page Up] / [Page Down] or [+]/[-] keys to set the current date. Follow the month, day and year format.

Highlight the <Time> field and then press the [Page Up] / [Page Down] or [+]/[-] keys to set the current date. Follow the hour, minute and second format.

The user can bypass the date and time prompts by creating an AUTOEXEC.BAT file. For information on how to create this file, please refer to the MS-DOS manual.

Hard Disk Setup

The BIOS supports various types for user settings, The BIOS supports <Pri Master>, <Pri Slave>, <Sec Master> and <Sec Slave> so the user can install up to two hard disks. For the master and slave jumpers, please refer to the hard disk's installation descriptions and the hard disk jumper settings in section three of this manual.

You can select <AUTO> under the <TYPE> and <MODE> fields. This will enable auto detection of your IDE drives during boot-up. This will allow you to change your hard drives (with the power off) and then power on without having to reconfigure your hard drive type. If you use older hard disk drives, which do not support this feature, then you must configure the hard disk drive in the standard method as described above by the <USER> option.

Floppy Setup

The <Standard CMOS Setup> option records the types of floppy disk drives installed in the system.

To enter the configuration value for a particular drive, highlight its corresponding field and then select the drive type using the left-or right-arrow key.

Boot Sector Virus Protection

This option protects the boot sector and partition table of your hard disk against accidental modifications. Any attempt to write to them will cause the system to halt and display a warning message. If this occurs, you can either allow the operation to continue or use a bootable virus -free floppy disk to reboot and investigate your system. The default setting is **<Disabled>**. This setting is recommended because it conflicts with new operating systems. Installation of new operating systems requires that you disable this to prevent write errors.

5.3 ADVANCED CMOS SETUP

The <Advanced CMOS Setup> option consists of configuration entries that allow you to improve your system performance, or let you set up some system features according to your preference. Some entries here are required by the CPU board's design to remain in their default settings.

AMIBIOS SETUP - ADVANCED CMOS SETUP (C) 1998 American Megatrends, Inc. All Rights Reserved		
1st Boot Device	IDE-	Available Options : Disabled IDE-0 IDE-1 IDE-2 IDE-3 Floppy ARMD-FDD ARMD-HDD CDROM SCSI NETWORK
0		
2nd Boot Device		
Floppy		
3rd Boot Device		
CDROM		
4th Boot Device		
Disabled		
Boot From Card BIOS	Yes	
Try Other Boot Devices	Yes	
S.M.A.R.T. for Hard Disks	Disabled	
Quick Boot		
Disabled		
BootUp Num-Lock	On Floppy	
Drive Swap	Disabled	
Floppy Drive Seek	Disabled	
Floppy Access Control	Normal	
HDD Access Control		
Normal		
PS/2 Mouse Support		
Enabled		
Typematic Rate	Fast	
System Keyboard	Absent	
Primary Display		
Absent		
Password Check		
Setup		
Boot to OS/2, DRAM 64MB or Above	No	
Wait For 'F1' If Error		
Disabled		
Hit 'DEL' Message Display	Enabled	
Internal Cache		
WriteBack		
External Cache		
WriteThru		
System BIOS Cacheable	Enabled	
C000, 16k Shadow	Enabled	
C400, 16k Shadow	Enabled	
C800, 16k Shadow	Disabled	
CC00, 16k Shadow	Disabled	
D000, 16k Shadow	Disabled	
D400, 16k Shadow	Disabled	
D800, 16k Shadow	Disabled	
DC00, 16k Shadow	Disabled	

Figure 0-5 BIOS: Advanced CMOS Setup

1st Boot Device

2nd Boot Device

3rd Boot Device

4th Boot Device

These options determine where the system looks first for an operating system.

Quick Boot

This category speeds up Power On Self Test (POST) after you power on the computer. If it is set to **Enabled**, BIOS will shorten or skip some check items during POST.

Boot Up Num-Lock

This item is used to activate the Num-Lock function upon system boot. If the setting is on, after a boot, the Num-Lock light is lit, and user can use the number key.

Floppy Drive Swap

The option reverses the drive letter assignments of your floppy disk drives in the Swap A, B setting, otherwise leave on the setting of **Disabled** (No Swap). This works separately from the BIOS Features floppy disk swap feature. It is functionally the same as physically interchanging the connectors of the floppy disk drives. When **<Enabled>**, the BIOS swapped floppy drive assignments so that Drive A becomes Drive B, and Drive B becomes Drive A under DOS.

Floppy Drive Seek

If the <Floppy Drive Seek> item is setting **Enabled**, the BIOS will seek the floppy <A> drive one time upon boot up.

PS/2 Mouse Support

The setting of **Enabled** allows the system to detect a PS/2 mouse on boot up. If detected, IRQ12 will be used for the PS/2 mouse. IRQ 12 will be reserved for expansion cards if a PS/2 mouse is not detected. **Disabled** will reserve IRQ12 for expansion cards and therefore the PS/2 mouse will not function.

Typematic Rate

This item specifies the speed at which a keyboard keystroke is repeated.

System Keyboard

This function specifies that a keyboard is attached to the computer.

Primary Display

The option is used to set the type of video display card installed in the system.

Password Check

This option enables password checking every time the computer is powered on or every time the BIOS Setup is executed. If **Always** is chosen, a user password prompt appears every time the computer is turned on. If **Setup** is chosen, the password prompt appears if the BIOS executed.

Boot to OS/2, DRAM 64MB or Above

When using the OS/2 operating system with installed DRAM of greater than 64MB, you need to **Enabled** this option otherwise leave this on the setup default of **Disabled**.

Wait for μ F1 \uparrow If Error

AMIBIOS POST error messages are followed by:

Press <F1> to continue

If this option is set to **Disabled**, the AMIBIOS does not wait for you to press the <F1> key after an error message.

Hit μ DEL \uparrow Message Display

Set this option to **Disabled** to prevent the message as follows:

Hi t \uparrow DEL. if you want to run setup

It will prevent the message from appearing on the first BIOS screen when the computer boots.

Internal Cache

This option specifies the caching algorithm used for L1 internal cache memory. The settings are:

Setting	Description
Disabled	Neither L1 internal cache memory on the CPU or L2 secondary cache memory is enabled.
WriteBack	Use the write-back caching algorithm.
WriteThru	Use the write-through caching algorithm.

Table 0-1 Internal Cache Setting

External Cache

This option specifies the caching algorithm used for L2 secondary (external) cache memory. The settings are:

Setting	Description
Disabled	Neither L1 internal cache memory on the CPU or L2 Secondary cache memory is enabled.
WriteBack	Use the write-back caching algorithm.
WriteThru	Use the write-through caching algorithm.

Table 0-2 External Cache Setting

System BIOS Cacheable

When this option is set to **Enabled**, the contents of the F000h system memory segment can be read from or written to L2 secondary cache memory. The contents of the F000h memory segment are always copied from the BIOS ROM to system RAM for faster execution.

The settings are **Enabled** or **Disabled**. The <Optimal default settings> is **Enabled**. The <Fail-Safe default setting> is **Disabled**.

Shadow

These options control the location of the contents of the 32KB of ROM beginning at the specified memory location. If no adapter ROM is using the named ROM area, this area is made available to the local bus. The settings are:

SETTING	DESCRIPTION
Disabled	The video ROM is not copied to RAM. The contents of the video ROM cannot be read from or written to cache memory.
Enabled	The contents of C000h - C7FFFh are written to the same address in system memory (RAM) for faster execution.
Cached	The contents of the named ROM area are written to the same address in system memory (RAM) for faster execution, if an adapter ROM will be using the named ROM area. Also, the contents of the RAM area can be read from and written to cache memory.

Table 0-3 Shadow Setting

5.4 ADVANCED CHIPSET SETUP

This option controls the configuration of the board's chipset. Control keys for this screen are the same as for the previous screen.

AMIBIOS SETUP - ADVANCED CHIPSET SETUP (C) 1998 American Megatrends, Inc. All Rights Reserved		
DRAM Automatic Configuration	Enabled	Available Options : Disabled Enabled
EDO Dram Access Time	60ns	
FP Dram Access Time	None Used	
Refresh Cycle Time	187.2US RAS	
Pulse Width When Refresh	7T DRAM	
Read Leadoff Time	1T	
ISA Bus Clock Frequency	7.159MHZ	
MEMORY HOLE at 15M - 16M	Disabled	
USB Function	Disabled	
USB Keyboard / Mouse Legacy Support	Disabled	
VGA Shared Memory Size	1M VGA	ESC:Exit F1:Sel PgUp/PgDn:Modify F2/F3:Color
Frequency	55MHz	

Figure 0-6 BIOS: Advanced Chipset Setup

DRAM Automatic Configuration

If selecting a certain setting for one BIOS Setup option determines the settings for one or more other BIOS Setup options, the BIOS automatically assigns the dependent settings and does not permit the end user to modify these settings unless the setting for the parent option is changed. Invalid options are grayed and cannot be selected.

Memory Hole at 15-16 MB

This option specifies the range 15MB to 16MB in memory that cannot be addressed on the ISA bus.

ISA Bus Clock Frequency

This option is used to select the ISA bus clock rate.

USB Function

USB Keyboard/Mouse Legacy Support

These options are used to **<Enabled>** the USB function and it's only useful in the DOS mode. The USB function sets **<Enabled>** will occupy IRQ10.

VGA Shared Memory Size

This option sets the VGA's occupied memory size.

VGA Frequency

This option sets the display's refresh.

AT Bus Clock

This option sets the polling clock speed of ISA Bus (PC/104).

NOTE: 1. PCLK means the CPU inputs clock.
2. Acrosser recommends user setting at the range of 8MHz to 10MHz.

Slow Refresh

This option sets the DRAM refresh cycle time.

RAS Precharge Time

The DRAM RAS precharge time.

Time Insert Wait

The DRAM time insert wait: RAS Active and CAS Precharge function setting.

ISA High Speed

The Speed field shows the speed at which the processor runs internally.

I/O Recovery

If I/O Recovery Feature options are enabled, the BIOS insert a delay time between two I/O commands. The delay time is defined in I/O Recovery Period option.

5.5 POWER MANAGEMENT

This section is used to configure power management features. This <Power management Setup> option allows you to reduce power consumption. This feature turns off the video display and shuts down the hard disk after a period of inactivity.

AMIBIOS SETUP - Power Management Setup (C) 1998 American Megatrends, Inc. All Rights Reserved		
Power Management /APM	Enabled	Available Options : Disabled Enabled
Video Power Down Mode	Disabled	
Hard Disk Power Down Mode	Disabled	
Hard Disk Time Out (Minute)	Disabled	
Standby Time Out (Minute)	Disabled	ESC:Exit L:Sel PgUp/PgDn:Modify F2/F3:Color
Suspend Time Out (Minute)	Disabled	
Slow Clock Ratio	1:4	
IRQ 3 – (COM2, COM4)	Monitor	
IRQ 4 – (COM1, COM3)	Monitor	
IRQ 5 – (LPT 2)	Ignore	
IRQ 7 – (LPT 1)	Monitor	
IRQ 9	Ignore	
IRQ 10	Ignore	
IRQ 11	Ignore	
IRQ 12 (PS2 Mouse)	Monitor	
IRQ 14	Monitor	
IRQ 15	Monitor	

Figure 0-7 BIOS: Power Management Setup

Power Management /APM

Enabled this option is to enable the power management and APM (Advanced Power Management) features.

Video Power Down Mode

This option specifies the power management states that the video subsystem enters after the specified period of display inactivity have expired.

Hard Disk Power Down Mode

This option specifies the power management states that the hard disk drive enters after the specified period of display inactivity have expired.

Hard Disk Time Out

This option specifies the length of a period of hard disk inactivity. When this period expired, the hard disk drive enters the power-conserving mode specified on the <Hard Disk Power Down Mode> option.

Standby Time Out**Suspend Time Out**

These options specify the length of the period of system inactivity when the computer is already in Standby mode before the computer is placed on Suspend mode. In Suspend mode, nearly all power use is curtailed.

Slow Clock Ratio

This option specifies the speed at which the system clock runs in power saving modes. The settings are expressed as a ratio between the normal clock speed and the power down clock speed.

IRQ

These options enable event monitoring. When the computer is in a power saving mode, activity on the named interrupt request line is monitored by BIOS. When any activity occurs, the computer enters Full On mode.

5.6 PCI/PLUG AND PLAY

This section is used to configure PCI / Plug and Play features. The <PCI & PnP Setup> option configures the PCI bus slots. All PCI bus slots on the system use INTA#, thus all installed PCI cards must be set to this value.

AMBIOS SETUP - PCI/PLUG AND PLAY SETUP (C) 1998 American Megatrends, Inc. All Rights Reserved		
Plug and Play Aware O/S	Yes	Available Options : Yes No
Clear NVRAM	No	
PCI Latency Timer (PCI Clocks)	64	
PCI IDE BusMaster	Disabled	
DMA Channel 0	PnP	
DMA Channel 1	PnP	
DMA Channel 3	PnP	
DMA Channel 5	PnP	
DMA Channel 6	PnP	
DMA Channel 7	PnP	
IRQ 3	PCI /PnP	
IRQ 4	PCI /PnP	
IRQ 5	PCI /PnP	
IRQ 7	PCI /PnP	
IRQ 9	PCI /PnP	
IRQ 10	PCI	
/PnP		
IRQ 11	PCI	
/PnP		
IRQ 12	PCI	
/PnP		
IRQ 14	PCI	
/PnP		
IRQ 15	PCI	
/PnP		
Reserved Memory Size	Disabled	
Reserved Memory Address C800		

Figure 0-8 BIOS: PCI / Plug and Play Setup

Plug and Play Aware O/S

Set this option to **Yes** if the operating system installed in the computer is Plug and Play-aware. The BIOS only detects and enables PnP ISA adapter cards that are required for system boot. The Windows 95 operating system detects and enables all other PnP-aware adapter cards. Windows 95 is PnP-aware. Set this option **<No>** if the operating system (such as DOS, OS/2, Windows 3.x) does not use PnP. You must set this option correctly or PnP-aware adapter cards installed in your computer will not be configured properly.

Clear NVRAM

This sets the operating mode of the boot block area of the BIOS FLASH ROM to allow programming in the **Yes** setting.

PCI Latency Timer (PCI Clocks)

This option sets latency of all PCI devices on the PCI bus. The settings are in units equal to PCI clocks.

PCI IDE BusMaster

Enabled this option is to specify that the IDE controller on the PCI local bus has bus mastering capability.

DMA & IRQ

These options specify the bus that the named IRQs/DMA lines are used on. These options allow you to specify IRQs/DMA for use by legacy ISA adapter cards. These options determine if the BIOS should remove an IRQ/DMA from the pool of available IRQs/DMA passed to BIOS configurable devices. If more IRQs/DMA must be removed from the pool, the end user can use these PCI/PnP Setup options to remove the IRQ/DMA by assigning the option to the ISA/EISA setting. Onboard I/O is configurable by BIOS.

Reserved memory Size

This option specifies the size of the memory area reserved for legacy ISA adapter cards.

Reserved memory Address

This option specifies the beginning address (in hex) of the reserved memory area. The specified ROM memory area is reserved for use by legacy ISA adapter cards.

5.7 PERIPHERAL SETUP

This section is used to configure peripheral features.

AMIBIOS SETUP - PERIPHERAL SETUP (C) 1998 American Megatrends, Inc. All Rights Reserved		
OnBoard FDC	Auto	Available Options : Auto Disabled Enabled
OnBoard Serial Port1	Auto	
OnBoard Serial Port2	Auto	
OnBoard Parallel Port	Auto	
Parallel Port Mode	Normal	Enabled
Parallel Port IRQ	Auto	
Parallel Port DMA Channel	N/A	
OnBoard PCI IDE	Enabled	
Primary Master Prefetch	Enabled	ESC:Exit L:Sel PgUp/PgDn:Modify F2/F3:Color
Primary Slave Prefetch	Enabled	

Figure 0-9 BIOS: Peripheral Setup

OnBoard FDC

This option enables the floppy drive controller on the 3307558.

OnBoard Serial Port

This option enables the serial port on the 3307558.

OnBoard Parallel Port

This option enables the parallel port on the 3307558

Parallel Port Mode

This option specifies the parallel port mode. ECP and EPP are both bi-directional data transfer schemes that adhere to the IEEE 284 specifications.

Parallel Port DMA Channel

This option is only available if the setting for the parallel Port Mode option is ECP.

OnBoard PCI MASTER/SLAVE Prefetch

This option specifies the onboard IDE controller channels that will be used.

5.8 AUTO-DETECT HARD DISKS

This option detects the parameters of an IDE hard disk drive, and automatically enters them into the Standard CMOS Setup screen.

5.9 PASSWORD SETTING

This BIOS Setup has an optional password feature. The system can be configured so that all users must enter a password every time the system boots or when BIOS Setup is executed. User can set either a Supervisor password or a User password.

Select the appropriate password icon (Supervisor or User) from the Security section of the BIOS Setup main menu. Enter the password and press [Enter]. The screen does not display the characters entered. After the new password is entered, retype the new password as prompted and press [Enter].

If the password confirmation is incorrect, an error message appears. If the new password is entered without error, press [Esc] to return to the BIOS Main Menu. The password is stored in CMOS RAM after BIOS completes. The next time the system boots, you are prompted for the password function is present and is enabled.

Enter new supervisor password:

5.10 LOAD DEFAULT SETTING

This section permits users to select a group of settings for all BIOS Setup options. Not only can you use these items to quickly set system configuration parameters, you can choose a group of settings that have a better chance of working when the system is having configuration related problems.

5.10.1 Auto Configuration with Optimal Setting

The user can load the optimal default settings for the BIOS. The Optimal default settings are best-case values that should optimize system performance. If CMOS RAM is corrupted, the optimal settings are loaded automatically.

Load high performance setting (Y/N) ?

5.10.2 Auto Configuration with Fail Safe Setting

The user can load the Fail-Safe BIOS Setup option settings by selecting the Fail-Safe item from the Default section of the BIOS Setup main menu.

The Fail-Safe settings provide far from optimal system performance, but are the most stable settings. Use this option as a diagnostic aid if the system is behaving erratically.

Load fail safe settings (Y/N) ?

5.11 BIOS EXIT

This section is used to exit the BIOS main menu. After making your changes, you can either save them or exit the BIOS menu and without saving the new values.

5.11.1 Save Settings and Exit

This item is in the <Standard CMOS Setup>, <Advanced CMOS Setup>, <Advanced Chipset Setup> and the new password (if it has been changed) will be stored in the CMOS. The CMOS checksum is calculated and written into the CMOS.

As you select this function, the following message will appear at the center of the screen to assist you to save data to CMOS and Exit the Setup.

Save current settings and exit (Y/N) ?

5.11.2 Exit Without Saving

When you select this option, the following message will appear at the center of the screen to help to abandon all the modified data and Exit Setup.

Quit without saving (Y/N) ?

5.12 BIOS UPDATE

The BIOS program instructions are contained within computer chips called FLASH ROMs that are located on your system board. The chips can be electronically reprogrammed, allowing you to upgrade your BIOS firmware without removing and installing chips.

The 3307558 provides FLASH BIOS update function for you to easily upgrade newer BIOS version. Please follow the operating steps for updating new BIOS:

Step 1: Turn on your system and don't detect the CONFIG.SYS and AUTOEXEC.BAT files. ***The importance is that the system has to load the HIMEM.SYS on the memory in the CONFIG.SYS file.***

Step 2: Insert the FLASH BIOS diskette into the floppy disk drive.

Step 3: In the MS-DOS mode, you can type the AMIFLASH program.

```
A:\>FLASH634
```

Step 4: The screen will show the message as follow:

Enter the BIOS File name from which Flash EPROM will be programmed. The File name must and with a <ENTER> or press <ESC> to exit.

Step 5: And then please enter the file name to the box of <Enter File Name>. And the box of <Message> will show the notice as follow. In the bottom of this window always show the gray statement.

Flash EPROM Programming is going to start. System will not be usable until Programming of Flash EPROM is successfully complete. In case of any error, existing Flash EPROM must be replaced by new program Flash EPROM.

Step 6: As the gray statement, press the <Y> key to updating the new BIOS. And then the <Message> box will show the <Programming Flash EPROM>, and the gray statement shows <Please Wait>.

Step 7: The BIOS update is successful, the message will show <Flash Update Completed - Pass>.

-
- NOTE:** 1. after turn on the computer and the system didn't detect the boot procedure, please press the [F5] key immediately. The system will pass the CONFIG.SYS and AUTOEXEC.BAT files. ***The importance is that the system has to load the HIMEM.SYS on the memory in the CONFIG.SYS file.***
2. The BIOS Flash disk is not the standard accessory. Now the onboard BIOS is the newest BIOS, if user needs adding some functions in the future please contact technical supporting engineers, they will provide the newest BIOS for updating.
3. The file of FLASH634.EXE had to Version 6.34.

Note

If the content in setting is inconsistent with the CD-ROM. Please refer to the setting as the priority

Contact Information

Thank you for purchasing from Global American Inc. We will stand by our slogan,

Integration with Integrity.

Please let us know how your product is performing and if we can help you with any future product lines.

Address 17 Hampshire Drive

Hudson, NH 03051

TEL (800) 833 8999

FAX (603) 886 4545

Website <http://www.globalamericaninc.com>

E-mail salesinfo@globalamericaninc.com (Sales)

support@globalamericaninc.com (Tech Support)