



integration with integrity

**User's Manual**

**3.5" Embedded Controller 3307620**

**Version 1.0**

---

---

## **Copyrights**

This manual is copyrighted and all rights are reserved. It does not allow any non authorization in copied, photocopied, translated or reproduced to any electronic or machine readable form in whole or in part without prior written consent from the manufacturer.

In general, the manufacturer will not be liable for any direct, indirect, special, incidental or consequential damages arising from the use of inability to use the product or documentation, even if advised of the possibility of such damages. The manufacturer keeps the rights in the subject to change the contents of this manual without prior notices in order to improve the function design, performance, quality and reliability. The author assumes no responsibility for any errors or omissions, which may appear in this manual, nor does it make a commitment to update the information contained herein.

## **Trademarks**

Intel is a registered trademark of Intel Corporation.  
Award is a registered trademark of Award Software, Inc.

All other trademarks, products and or product's name mentioned herein are mentioned for identification purposes only, and may be trademarks and/or registered trademarks of their respective companies or owners.

# Packing List

Please check the package before you starting setup the system

## Hardware:

3307620 little board x 1

## Cable Kit:

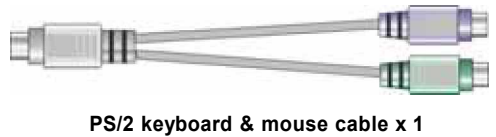
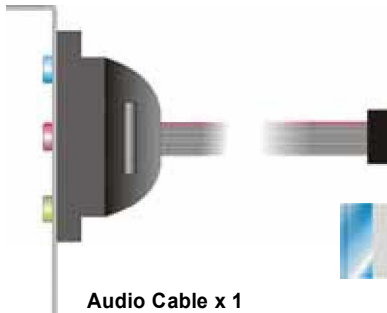
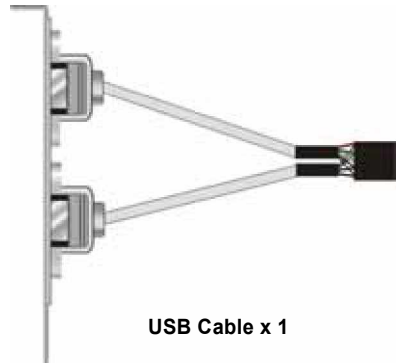
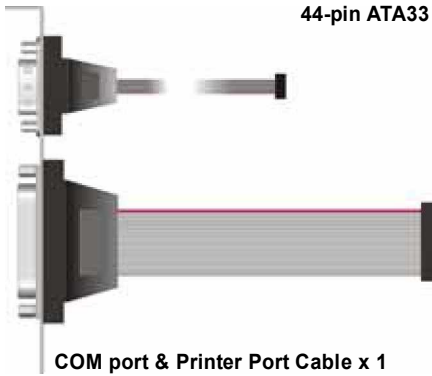

## Other Accessories:

Divers CD (including User's Manual) x 1

Printed User's Manual x 1

## Index

<b>Chapter 1 &lt;Introduction&gt;</b> .....	<b>6</b>
1.1 <Product Overview>.....	6
1.2 <Product Specification> .....	7
1.3 <Mechanical Drawing>.....	9
1.4 <Block Diagram>.....	10
<b>Chapter 2 &lt;Hardware Setup&gt;</b> .....	<b>11</b>
2.1 <Connector Location> .....	11
2.2 <Jumper Location & Reference> .....	12
2.3 <Connector Reference> .....	13
2.3.1 <Internal Connector>.....	13
2.3.2 <External Connector>.....	13
2.4 <CPU & Memory Setup>.....	14
2.4.1 <CPU>.....	14
2.4.2 <Memory> .....	14
2.5 <CMOS Setup> .....	15
2.6 <Enhanced IDE & CF Interface>.....	16
2.7 <Floppy Port>.....	17
2.8 <Ethernet Interface> .....	18
2.9 <Onboard Display Interface> .....	19
2.10 <Onboard Audio Interface>.....	26
2.11 <Serial Port> .....	27
2.12 <GPIO Interface> .....	28
2.13 <Power Supply> .....	29
2.13.1 <Power output> .....	29
2.13.2 <Power Output> .....	29
2.14 <Switch and Indicator>.....	30

<b>Appendix A &lt;I/O Pin Assignment&gt;</b> .....	<b>33</b>
A.1 <IDE Port> .....	33
A.2 <Floppy Port> .....	34
A.3 <IrDA Port> .....	34
A.4 <VGA Port >.....	34
A.5 <Serial Port> .....	35
A.6 <LAN Port> .....	35
A.7 <PS/2 Keyboard & Mouse Port>.....	35
<b>Appendix B &lt;System Resources&gt;</b> .....	<b>39</b>
B.1 <I/O Port Address Map> .....	39
B.2 <Memory Address Map> .....	41
B.3 <System IRQ & DMA Resources> .....	42
B.3.1 <IRQ> .....	42
B.3.2 <DMA> .....	41
<b>Contact Information</b> .....	<b>43</b>

# Chapter 1 <Introduction>

## 1.1 <Product Overview>

**3307620** is the 3.5 inches embedded motherboard with AMD Geode GX533 platform, with onboard VGA, AC97 audio, dual LAN and DC 12V input interface. Based on the AMD Geode GX533 processor, the board provides many advanced features for reduced power consumption, fanless design and high cost/price rate of production.

### Low Power Consumption

Based on the AMD Geode GX533@400MHz processor onboard, it only takes up to 8.4W at maximum powering, and is completely suitable for fanless design. Without any cooling fan onboard, it can avoid the heat problem when the cooler failed in accident.

### Onboard TTL/LVDS LCD interface

Based on the AMD Geode GX533@400Mhz of integrated graphics, the board provides onboard graphics with up to 4/8/12/16 MB of frame buffer, 18-bit/24-bit LVDS and 24-bit TTL interfaces.

### Embedded Component

Due to the low profile design, the board provides PCMICA card Bus, CF card socket for flash disk with porting embedded OS and up to 512MB of DDR SO-DIMM.

### Single Voltage Input

The board only requires DC 12V input; user's can easily connect the board with an adapter without the huge power supply.

## 1.2 <Product Specification>

### General Specification

Form Factor	3.5 inches embedded motherboard
CPU	Embedded AMD Geode GX533 400MHz <b>Fanless with heatsink only</b>
Memory	1 x 200-pin DDRSO-DIMM up to 512MB Unbuffered, none-ECC memory supported only
Chipset	AMD Geode CS5535
USB Port	Two internal USB1.1 ports
BIOS	Phoenix-Award PnP flash BIOS
Green Function	Power saving mode includes doze, standby and suspend modes. ACPI version 1.0 and APM version 1.2 compliant
Watchdog Timer	System reset programmable watchdog timer
Real Time Clock	Chipset built-in RTC with lithium battery
Enhanced IDE	One Ultra DMA33 IDE interface supports up to 2 ATAPI devices One 44-pin IDE port onboard

### Multi-I/O Port

Chipset	WINBOND W83627HF
Serial Port	One external RS232 and one internal RS232
Parallel Port	One 26-pin internal parallel port
Floppy Port	One slim type Floppy port
IrDA Port	One IrDA compliant Infrared interface supports SIR
K/B & Mouse	External PS/2 keyboard and mouse ports on rear I/O panel
GPIO	One 12-pin Digital I/O connector with 8-bit programmable I/O interface
Hardware Monitor	Fan speed, CPU temperature and voltage monitoring

### VGA Display Interface

Chipset	AMD Geode GX533 built-in VGA controller with 2D engine
Memory	BIOS selectable up to 4/8/12/16 MB shard with system memory
Display Type	CRT, LCD monitor with analog display 18-bit/24-bit LVDS/24-bit TTL with LCD interface
Connector	External DB15 female connector on rear I/O panel Onboard 40-pin TTL connector Onboard 40-pin LVDS connector Onboard 5-pin backlight inverter connector

### Solid State Disk Interface

Compact Flash	1 x Compact Flash Card Type I socket on solder side
DOM	Onboard 44-pin IDE support DOM (Disk On Module)
PCMCIA Card	PCMICA Type I/II slot

**Ethernet Interface**

Controller	Dual PCI based REALTEK 8100B controller
Type	10Base-T / 100Base-TX, auto-switching Fast Ethernet Full duplex, IEEE802.3U compliant
Connector	Two external RJ45 jack on I/O panel

**Audio Interface**

Controller	REALTEK ALC201A AC97 codec
Output Interface	Line-in, Line-out, CD-in, MIC-in
Connector	Onboard 10-pin header

**Expansion Interface**

Mini PCI	Onboard Mini PCI socket for Type III (32bit,33Mhz)
----------	--

**Power and Environment**

Power requirement	DC 12V input 1 x DC jack on I/O panel 1 x Onboard 4-pin 12V DC connector
Input Voltage	10.5V ~ 13V
Input Current	12V/0.7A 8.4W (board only)
Dimension	146mm x 101mm (L x W)
Temperature	Operating within 0 ~ 60°C (32 ~ 140°F) Storage within -20 ~ 85°C (-4 ~ 185°F)

**Driver support**

Windows	Windows XP/XPe, Win2000 and WinCE
Linux	Kernel version 2.8 or later

**Ordering Code**

3307620A	3.5" Embedded Controller with onboard AMD GX533 400MHz processor, VGA, audio, dual LAN, USB, CF, TTL/LVDS PCMAIC ,Mini PCI , GPIO
3307620B	Same as 3307620A and with onboard DDR 128M



### 1.3 <Mechanical Drawing>

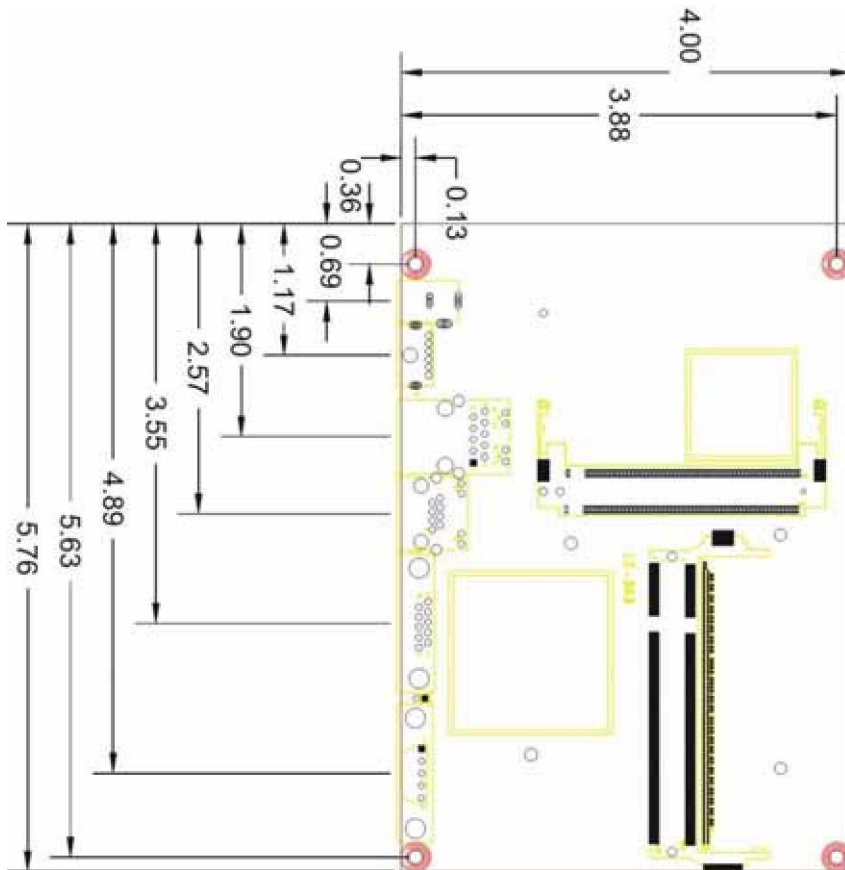

### 1.4 <Block Diagram>

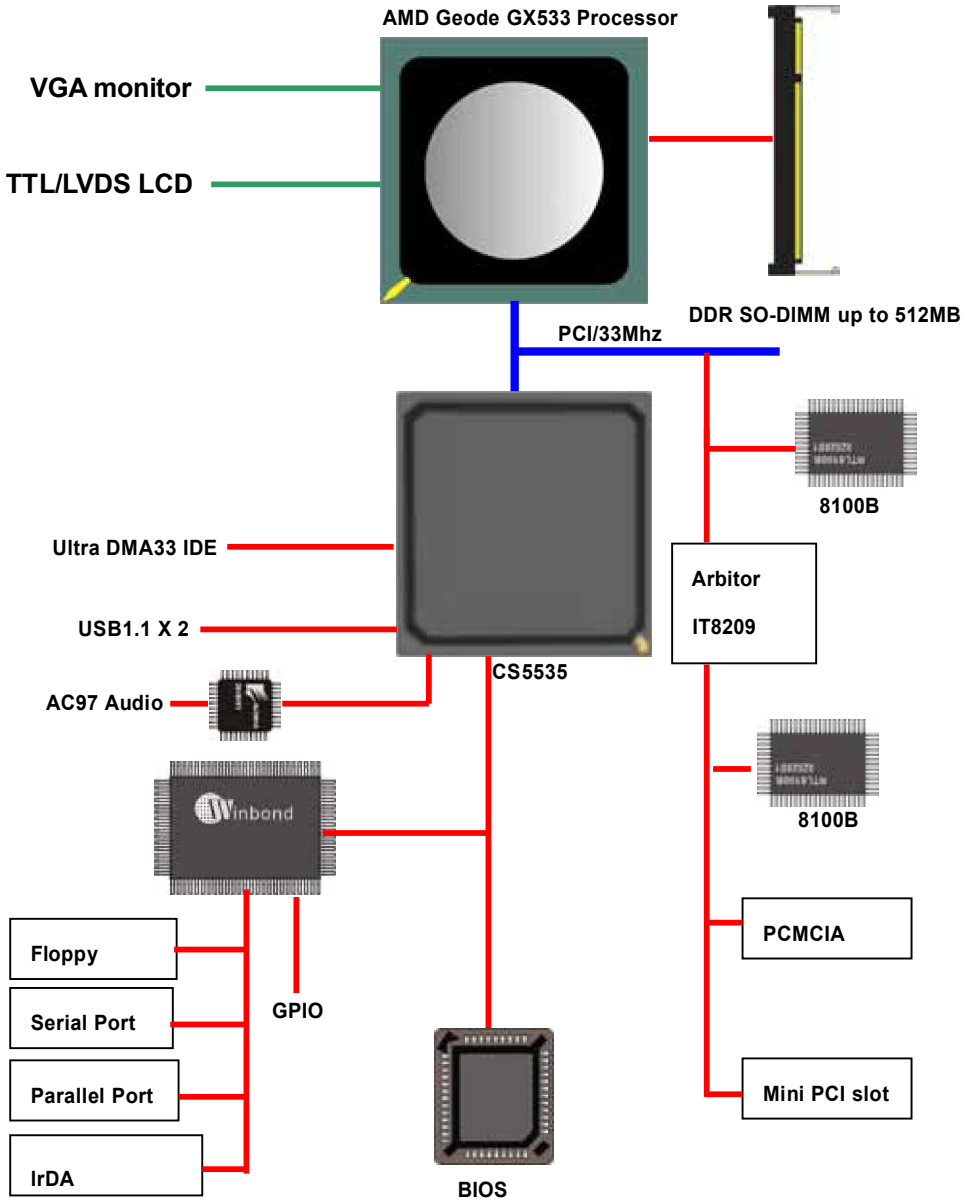

# Chapter 2 <Hardware Setup>

## 2.1 <Connector Location>

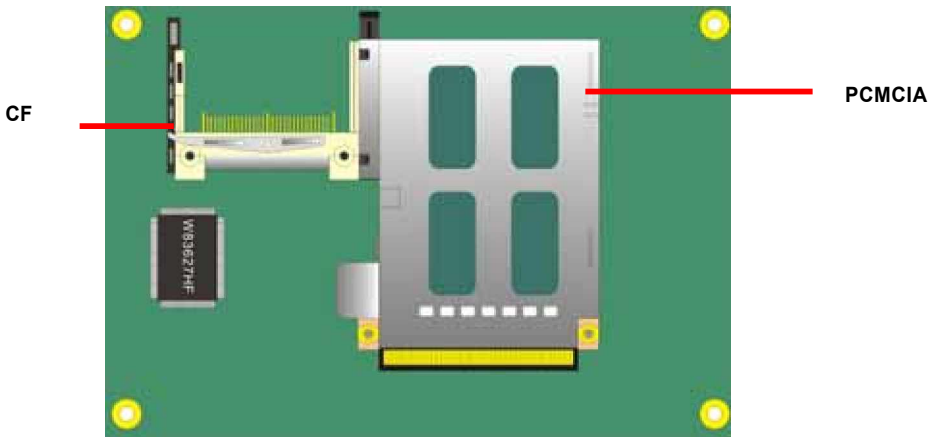
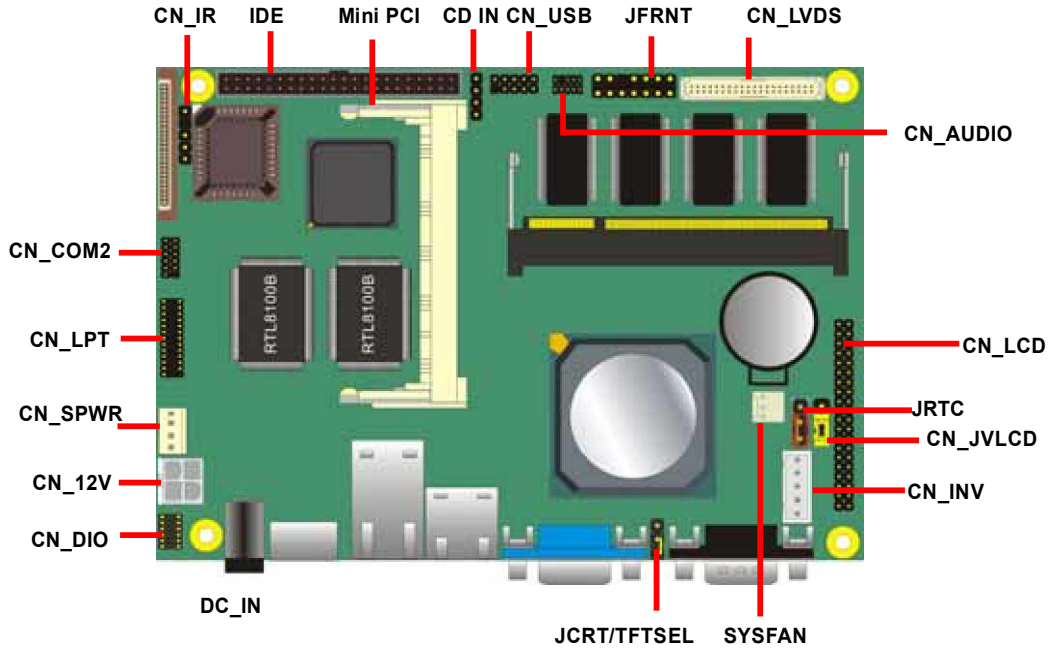

## 2.2 <Jumper Location & Reference>

Jumper	Function
JRTC	RTC/CMOS Setting
JVLCD	LCD Driving Voltage Setting
JCRT/TFTSEL	Select CRT/TFT Setting

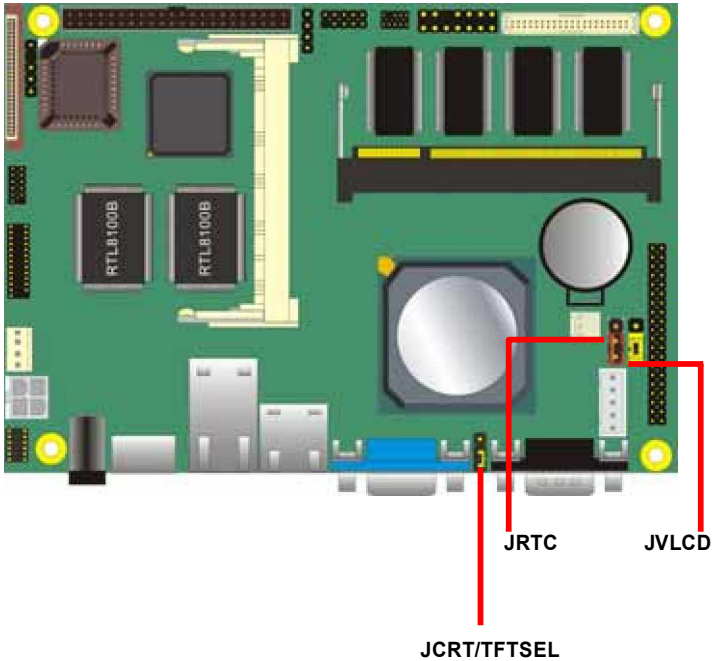

## 2.3 <Connector Reference>

### 2.3.1 <Internal Connector>

Connector	Function	Remark
DIMM	Onboard 200-pin DDR SO-DIMM socket	Standard
IDE	44-pin primary IDE connector	Slim
FDD	26-pin slim type floppy connector	Slim
CN_12V	4-pin power supply connector	Standard
CN_AUDIO	5 x 2-pin audio connector	Standard
CDIN	4-pin CD-ROM audio input connector	Standard
CN_DIO	6 x 2-pin digital I/O connector	Standard
CN_USB	5 x 2-pin USB connector	Standard
SYSFAN	3-pin system cooler fan connector	Standard
CN_COM2	5 x 2-pin RS232 serial port	Standard
CN_IR	5-pin IrDA connector	Standard
CF	Compact Flash Type I socket (Solder Side)	Standard
PCMICA	PCMICA Card bus Type I/II slot(Solder Side)	Standard
LPT	26-pin parallel port connector	Standard
CN_TTL	40-pin TTL LCD interface	Standard
CN_LVDS	20-pin LVDS LCD interface	Standard
CN_INV	5-pin LCD backlight inverter connector	Standard
CN_SPWR	4-pin 5V/12V power output connector	Standard
JFRNT	14-pin front panel switch/indicator connector	Standard

### 2.3.2 <External Connector>

Connector	Function	Remark
VGA	DB15 VGA connector	Standard
RJ45_1/2	RJ45 LAN connector	Standard
COM1	Serial port connector	Standard
PS2	PS/2 Keyboard/Mouse connector	Standard
DC_IN	DC 12V input jack	Standard

## 2.4 <CPU & Memory Setup>

### 2.4.1 <CPU>

The board integrates AMD Geode GX533 400MHz processor with special design for power appliance. It requires only 8.4W power consumption at most, and is totally designed for fanless system.

### 2.4.2 <Memory>

Based on AMD GX533 processor with built-in memory controller, the board provides one 200-pin DDR SO-DIMM socket support up to 512MB of capacity. To install the DDR SO-DIMM module, please insert the module into the socket at 45 degree, then press down the module with a click sound.



(1. Insert the DDR SO-DIMM module into the socket at 45 degree)

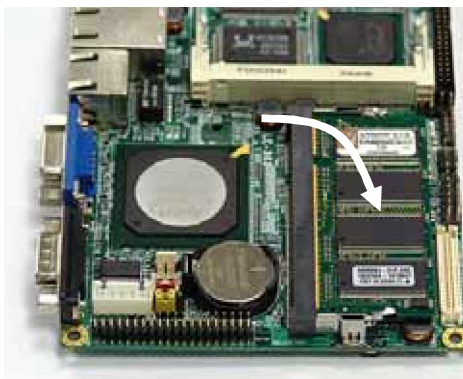

(2. Press down the module with a click sound)

## 2.5 <CMOS Setup>

The board's data of CMOS can be setting in BIOS. If the board refuses to boot due to inappropriate CMOS settings, here is how to proceed to clear (reset) the CMOS to its default values.

**Jumper: JRTC**

**Type: Onboard 3-pin jumper**

JRTC	Mode
1-2	Clear CMOS
2-3	Normal Operation

Default setting

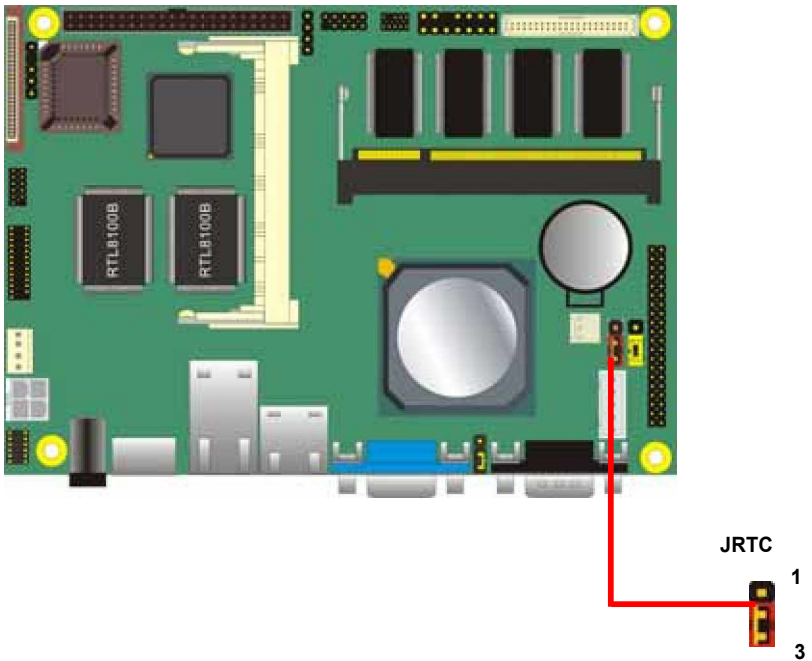

## 2.6 <Enhanced IDE & CF Interface>

The board supports one **Ultra DMA33 IDE** interface, dual channel for 2 ATAPI devices. The board also provides a **Compact Flash Type I** socket on secondary IDE channel and one onboard **type I/II PCMCIA** Card Bus on the solder side.

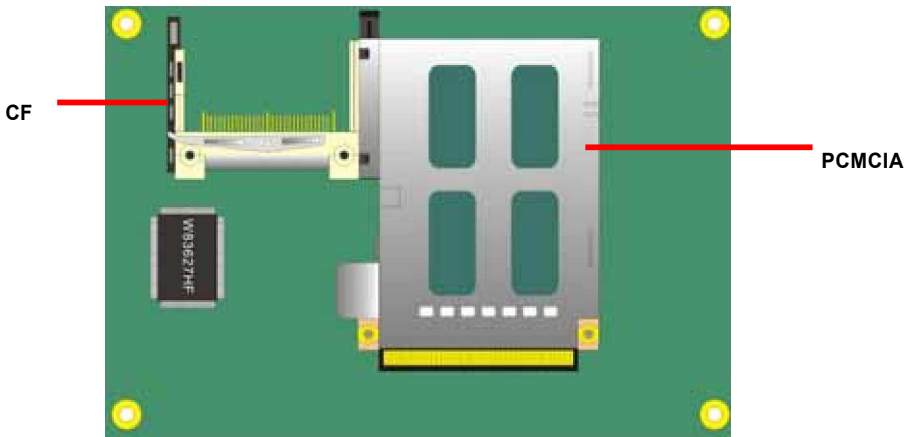
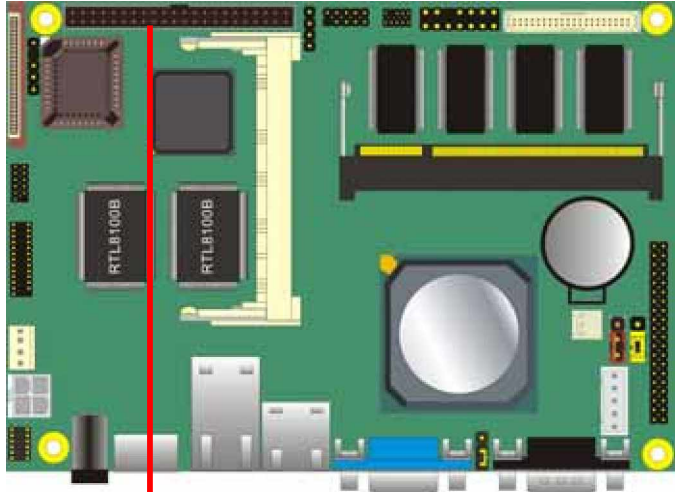



## 2.7 <Floppy Port>

The board provides a slim type floppy port; please use the 26-pin ribbon cable in the package to connect the floppy device.

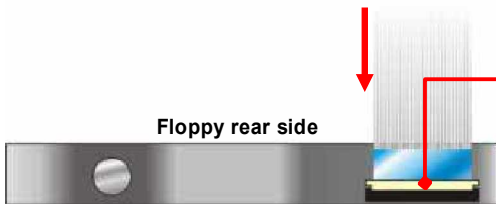
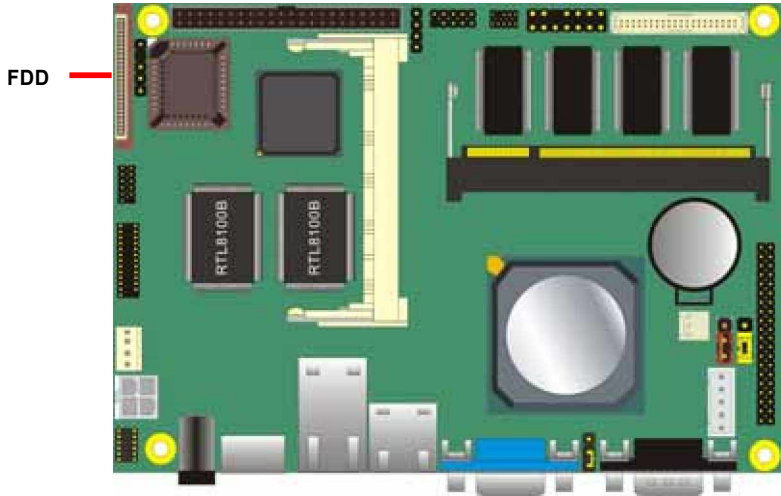

4. Lift up this plastic bar
5. Slot the cable in (Blue paste for outside)
6. Press back the plastic bar

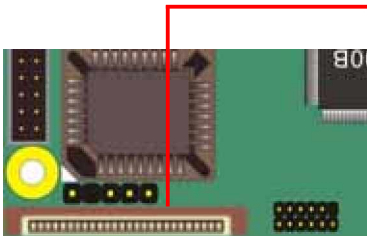

1. Lift up the brown plastic bar
2. Slot the cable in (Blue paste for brown bar side)
3. Press back the plastic bar

## 2.8 <Ethernet Interface>

The board integrates two PCI based Ethernet controller with REALTEK 8100B, full compliance with IEEE 802.3u 100Base-T specifications and IEEE 802.3x Full Duplex Flow Control.

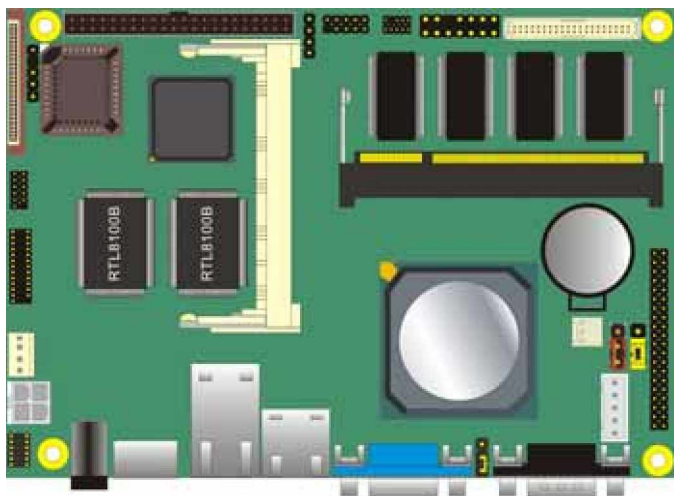

RJ45\_2 RJ45\_1

## 2.9 <Onboard Display Interface>

The board integrates AMD Geode GX533 processor with built-in 2D video engine, to provide onboard DB15 VGA connector, 24-bit TTL and 18-bit/24-bit LVDS interface. The built-in 2D video engine supports following specified functions:

H-performance 2D graphics controller

Alpha BLT

Integrated dot clock PLL

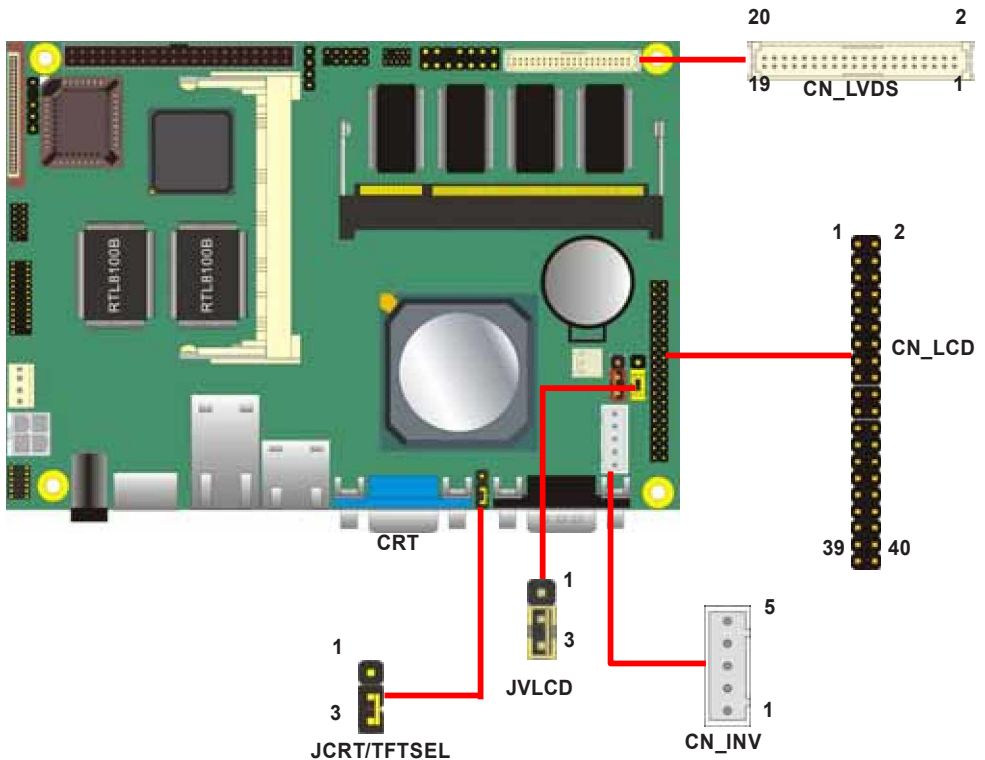

JCRT/TFTSEL	Mode
1-2	TFT
2-3	CRT
Default setting	

In order to setup the LCD display well, please check the jumper setting before you use.

Jumper: **JVLCD**

Type: onboard 3-pin header

JVOLT	Mode
1-2	+5V
2-3	+3.3V

Default setting

Connector: **CN\_INV**

Type: onboard 5-pin header

Pin	Description
1	+12V
2	Ground
3	Ground
4	Ground
5	ENBKL

Jumper: **JCRT/TFTSEL**

Type: onboard 3-pin header

JCRT/TFTSEL	Description
1	VCC
2	VGASEL
3	Ground

Connector: **CN\_LVDS ( for 24bit Signal channel LVDS panel )**

Type: 40-pin header (40 x 2 pitch 2.0 mm)

Connector model: **Hirose DF13- 40S**

Pin	Signal (18-bit)	Pin	Signal (24-bit)
2	LCDVCC	1	LCDVCC
4	GND	3	GND
6	NC	5	BTX0-
8	NC	7	BTX0+
10	GND	9	GND
12	NC	11	BTX1-
14	NC	13	BTX1+
16	GND	15	GND
18	NC	17	BTX2-
20	NC	19	BTX2+
22	GND	21	GND
24	NC	23	BTX3-
26	NC	25	BTX3+
28	GND	27	GND
30	NC	29	BTXCK-
32	NC	31	BTXCK+
34	GND	33	GND
36	N/C	35	N/C
38	N/C	37	N/C
40	N/C	39	N/C

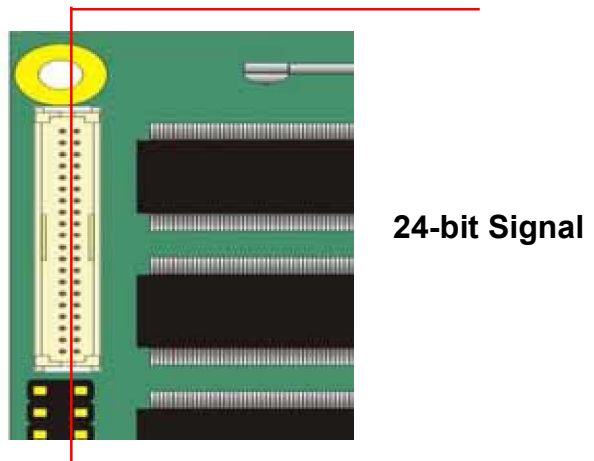

Connector: **CN\_LVDS ( for 18bit Signal channel LVDS panel )**

Type: 40-pin header (40 x 2 pitch 2.0 mm)

Connector model: **Hirose DF13- 40S**

Pin	Signal (18-bit)	Pin	Signal (24-bit)
2	LCDVCC	1	LCDVCC
4	GND	3	GND
6	ATX0-	5	NC
8	ATX0+	7	NC
10	GND	9	GND
12	ATX1-	11	NC
14	ATX1+	13	NC
16	GND	15	GND
18	ATX2-	17	NC
20	ATX2+	19	NC
22	GND	21	GND
24	ATXCK0-	23	NC
26	ATXCK1+	25	NC
28	GND	27	GND
30	N/C	29	NC
32	N/c	31	NC
34	GND	33	GND
36	N/C	35	N/C
38	N/C	37	N/C
40	N/C	39	N/C

**18-bit Signal**

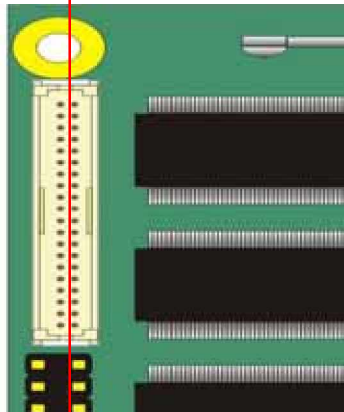

Connector: **CN\_LCD**

Type: onboard 2 x 20-pin header with housing, pitch=2.0mm

Pin	Signal	Pin	Signal
1	ENAVDD	2	ENBKL
3	GND	4	GND
5	LCDVCC	6	LCDVCC
7	GND	8	GND
9	FPD0	10	FPD1
11	FPD2	12	FPD3
13	FPD4	14	FPD5
15	FPD6	16	FPD7
17	FPD8	18	FPD9
19	FPD10	20	FPD11
21	FPD12	22	FPD13
23	FPD14	24	FPD15
25	FPD16	26	FPD17
27	FPD18	28	FPD19
29	FPD20	30	FPD21
31	FPD22	32	FPD23
33	N/C	34	N/C
35	FPCLK	36	VSYNC
37	RM	38	HSYNC
39	GND	40	GND

To setup the LCD, you need the component below:

1. A panel (support up to 18-bit/24-bit color) with TTL or LVDS interfaces.
2. An inverter for panel's backlight power.
3. A LCD cable and an inverter cable.

For the cables, please follow the pin assignment of the connector to make a cable, because every panel has its own pin assignment, so we do not provide a standard cable; please find a local cable manufacture to make cables.

## LCD Installation Guide:

1. Preparing the 3307620, LCD panel and the backlight inverter.

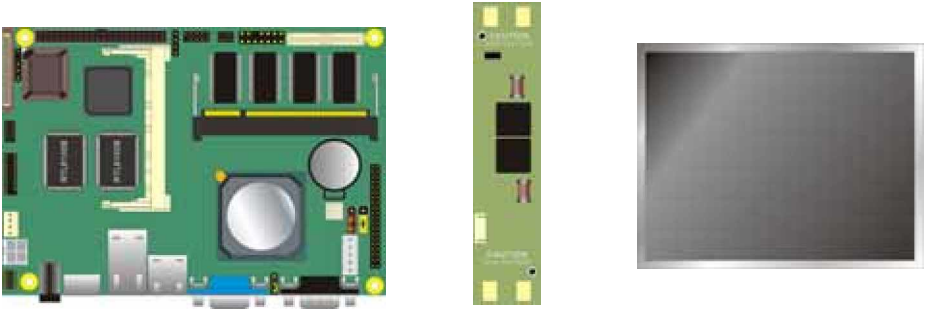

2. Please check the datasheet of the panel to see the voltage of the panel, and set the jumper **JVLCD** to +5V or +3.3V.
3. If your panel is for TTL interface, you would need a TTL type cable.



4. IF your panel is for LVDS interface, you would need a LVDS type cable.



5. To connect all of the devices well.

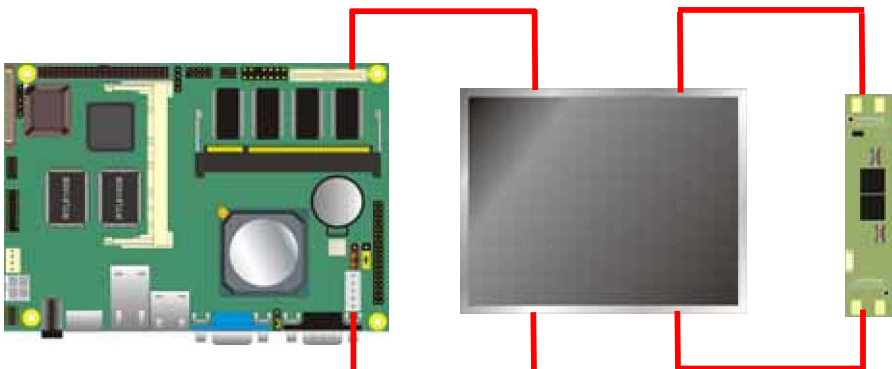



After hardware setup well, you need to select the panel type in the BIOS.

Panel Type Support List:

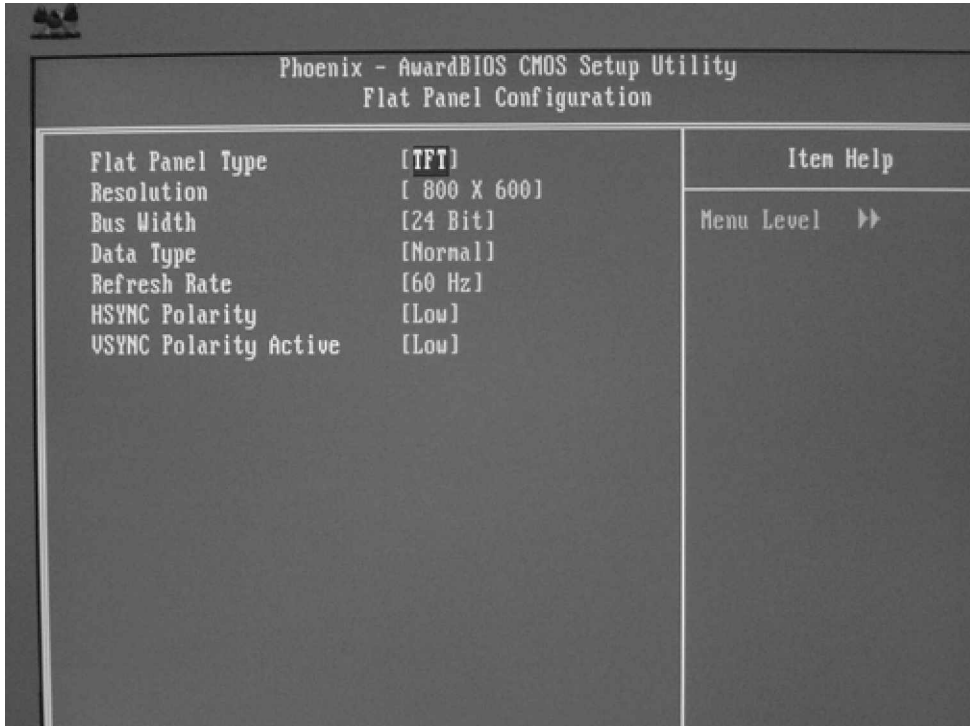

Panel Number Resolution	
1	640 x 480
2	800 x 600
3	1024x 768

## 2.10 <Onboard Audio Interface>

The board provides onboard AC97 audio interface with REALTEK ALC201A codec. Please use attached audio cable in the package to have Line-out, Line-in and MIC-in interfaces.

### Connector: CN\_AUDIO

Type: 10-pin (2 x 5) 1.27mm x 2.54mm-pitch header

Pin	Description	Pin	Description
1	Line – Right	2	Ground
3	Line – Left	4	MIC
5	MIC	6	Ground
7	N/C	8	Line Out – Left
9	Line Out – Right	10	Ground

### Connector: CDIN

Type: 4-pin header 2.54mm pitch header

Pin	Description
1	CD – Left
2	Ground
3	Ground
4	CD – Right

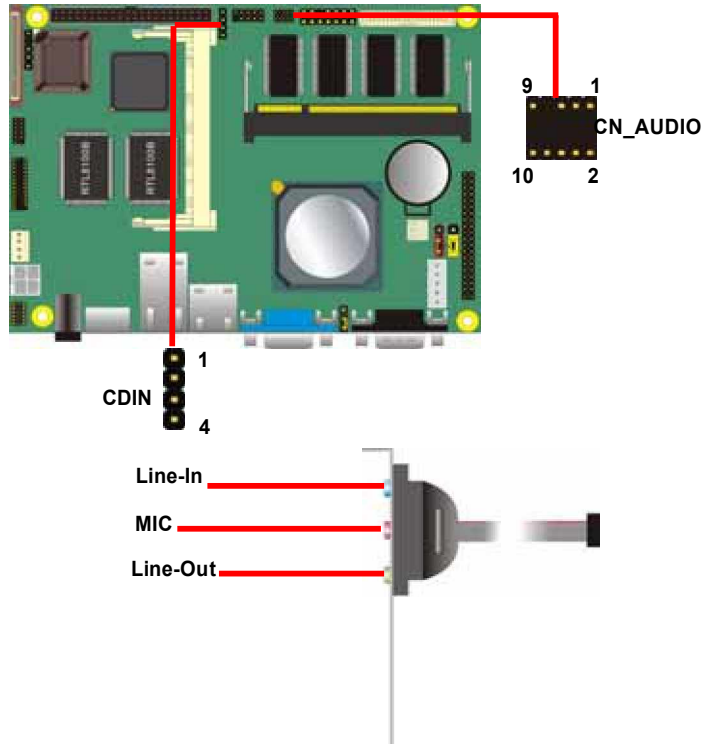

## 2.11 <Serial Port>

The board provides one RS232 COM port on real I/O panel with DB9 as COM1, onboard CN\_COM2 RS232 serial port and one onboard parallel connector.

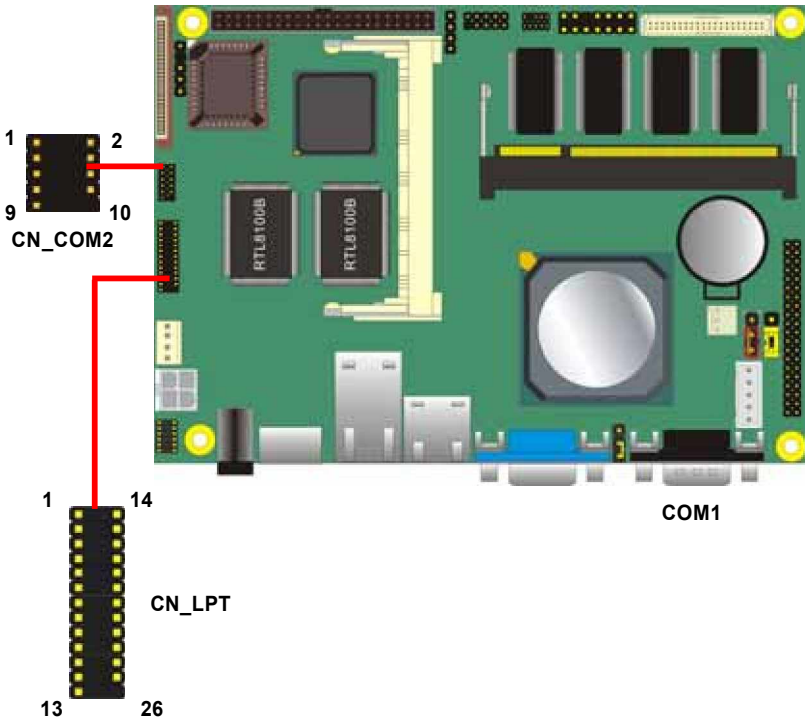

## 2.12 <GPIO Interface>

The board offers 8-bit digital I/O to customize its configuration to your control needs. For example, you may configure the digital I/O to control the opening and closing of the cash drawer or to sense the warning signal from a tripped UPS. The following is a detailed description of how the digital I/O is controlled via software programming.

Connector: **CN\_DIO**

Type: 12-pin (6 x 2) 1.27mm x 2.54mm-pitch header

Pin	Description	Pin	Description
1	Ground	2	Ground
3	D0	4	D4
5	D1	6	D5
7	D2	8	D6
9	D3	10	D7
11	+5V	12	+12V

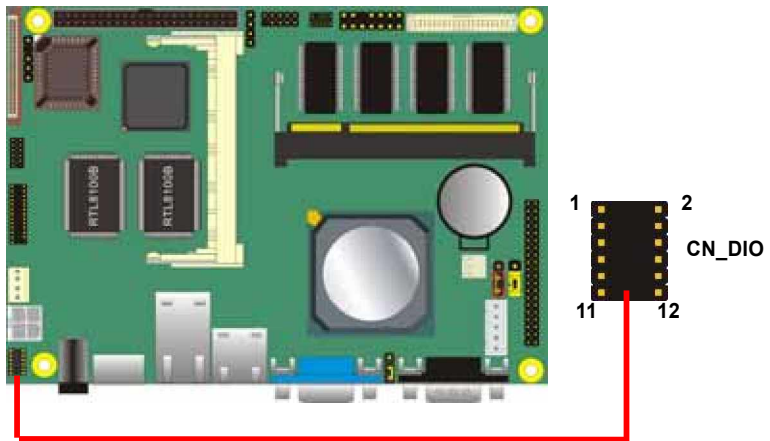

## 2.13 <Power Supply>

### 2.13.1 <Power Input>

The board requires DC 12V input with onboard DC jack or 4-pin 12V DC connector.

Connector: **CN\_12V**

Type: 4-pin standard ATX2.0 +12V power connector

Pin	Description	Pin	Description
1	Ground	2	Ground
3	+12V	4	+12V

### 2.13.2 <Power Output>

The board also provides one 4-pin connector with +5V/+12V output.

*PS: Maximum output current for 5V/1A & 12V/1A*

Connector: **CN\_SPWR**

Type: 4-pin P-type connector for +5V/+12V output

Pin	Description	Pin	Description	Pin	Description	Pin	Description
1	+12V	2	Ground	3	Ground	4	+5V

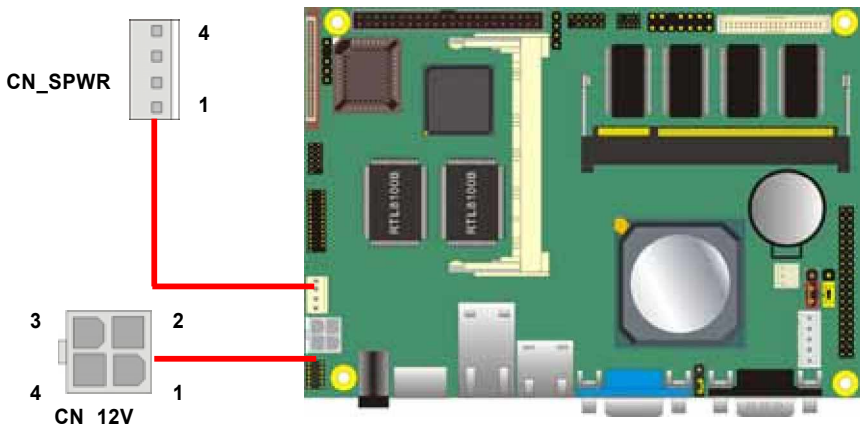

## 2.14 <Switch and Indicator>

The **JFRNT** provides front control panel of the board, such as power button, reset and beeper, etc. Please check well before you connecting the cables on the chassis.

Connector: **JFRNT**

Type: onboard 14-pin (2 x 7) 2.54-pitch header

Function	Signal	PIN		Signal	Function
IDE LED	HDLED	1	2	PWDLED	Power LED
	Active	3	4	N/C	
Reset	Reset	5	6	GND	Speaker
	GND	7	8	VCC	
N/C		9	10	N/C	
Power Button	PWRBT	11	12	N/C	
	5VSB	13	14	SPKIN	

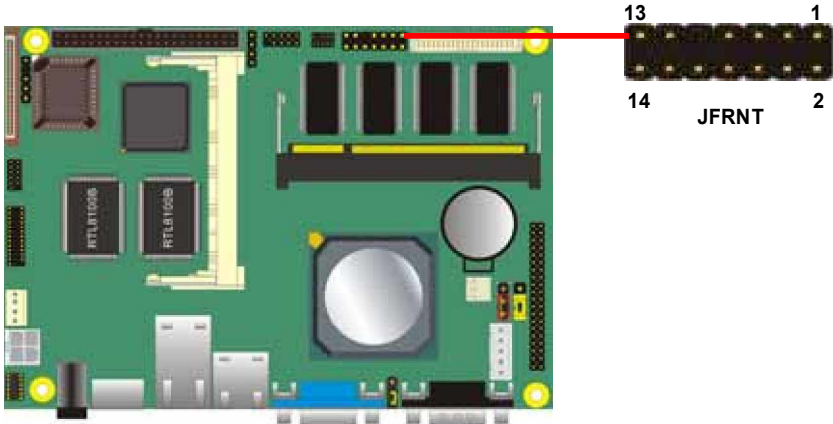

(This Page is Left For Blank)

## Appendix A <I/O Pin Assignment>

### A.1 <IDE Port>

Connector: **IDE**

Type: 44-pin (22 x 2) box header



Pin	Description	Pin	Description
1	Reset	2	Ground
3	D7	4	D8
5	D6	6	D9
7	D5	8	D10
9	D4	10	D11
11	D3	12	D12
13	D2	14	D13
15	D1	16	D14
17	D0	18	D15
19	Ground	20	N/C
21	REQ	22	Ground
23	IOW-/STOP	24	Ground
25	IOR-/HDMARDY	26	Ground
27	IORDY/DDMARDY	28	Ground
29	DACK-	30	Ground
31	INT	32	N/C
33	A1	34	N/C
35	A0	36	A2
37	CS0	38	CS1
39	LED2	40	Ground
41	VCC	42	VCC
43	Ground	44	Ground



## A.2 <Floppy Port>

Connector: **FDD**

Type: 26-pin connector



Pin	Description	Pin	Description
1	VCC	2	INDEX
3	VCC	4	DRX
5	VCC	6	DSKCHG
7	N/C	8	N/C
9	N/C	10	MTR0
11	RPM	12	DIR
13	N/C	14	STEP
15	Ground	16	WRITE DATA
17	Ground	18	WRITE GATE
19	Ground	20	TRACK 0
21	N/C	22	WRX
23	Ground	24	RDATA-
25	Ground	26	SEL

## A.3 <IrDA Port>

Connector: **CN\_IR**

Type: 5-pin header for SIR Ports



Pin	Description
1	VCC
2	N/C
3	IRRX
4	Ground
5	IRTX

## A.4 < VGA Port >

Connector: **CRT**

Type: 15-pin D-sub female connector on bracket

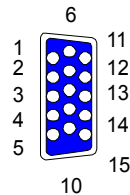

Pin	Description	Pin	Description	Pin	Description
1	RED	6	Ground	11	N/C
2	GREEN	7	Ground	12	5VSDA
3	BLUE	8	Ground	13	HSYNC
4	N/C	9	N/C	14	VSYSN
5	Ground	10	Ground	15	5VSCL

## A.5 <Serial Port>

Connector: **COM1**

Type: 9-pin D-sub male connector on bracket

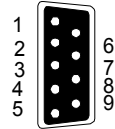

Pin	Description	Pin	Description
1	DCD	6	DSR
2	RXD	7	RTS
3	TXD	8	CTS
4	DTR	9	-XR
5	Ground		

## A.6 <LAN Port>

Connector: **RJ45\_1/2**

Type: RJ45 connector with LED on bracket

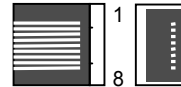

Pin	1	2	3	4	5	6	7	8
Description	TX+	TX-	RX+	RX-	N/C	N/C	N/C	N/C

## A.7 <PS/2 Keyboard & Mouse Port>

Connector: **PS2**

Type: 6-pin Mini-DIN connector on bracket



Pin	1	2	3	4	5	6
Description	KBD	MSD	Ground	VCC	KBC	MSC

Note: The PS/2 connector supports standard PS/2 keyboard directly or both PS/2 keyboard and mouse through the PS/2 Y-type cable.

## A.8 < USB Interface >

Connector: **CN\_USB**

Type: 10-pin (5 x 2) header for dual USB Ports



Pin	Description	Pin	Description
1	VCC	2	VCC
3	Data0-	4	Data1-
5	Data0+	6	Data1+
7	Ground	8	Ground
9	Ground	10	NC

(This Page is Left For Blank)

(This Page is Left For Blank)

## Appendix B <System Resources>

### B.1 <I/O Port Address Map>

[00000000 - 0000000F]	Direct memory access controller
[00000000 - 00000CF7]	PCI bus
[00000010 - 0000001F]	Motherboard resources
[00000020 - 00000021]	Programmable interrupt controller
[00000022 - 0000002D]	Motherboard resources
[00000030 - 0000003F]	Motherboard resources
[00000040 - 00000043]	System timer
[00000044 - 0000005F]	Motherboard resources
[00000060 - 00000060]	Standard 101/102-Key or Microsoft Natural PS/2 Keyboard
[00000061 - 00000061]	System speaker
[00000062 - 00000063]	Motherboard resources
[00000064 - 00000064]	Standard 101/102-Key or Microsoft Natural PS/2 Keyboard
[00000065 - 0000006F]	Motherboard resources
[00000070 - 00000073]	System CMOS/real time clock
[00000074 - 0000007F]	Motherboard resources
[00000080 - 00000090]	Direct memory access controller
[00000091 - 00000093]	Motherboard resources
[00000094 - 0000009F]	Direct memory access controller
[000000A0 - 000000A1]	Programmable interrupt controller
[000000A2 - 000000BF]	Motherboard resources
[000000C0 - 000000DF]	Direct memory access controller
[000000E0 - 000000EF]	Motherboard resources
[000000F0 - 000000FF]	Numeric data processor
[00000170 - 00000177]	Secondary IDE Channel
[000001F0 - 000001F7]	Primary IDE Channel
[00000274 - 00000277]	ISAPNP Read Data Port

[00000274 - 00000277]	ISAPNP Read Data Port
[00000279 - 00000279]	ISAPNP Read Data Port
[00000294 - 00000297]	Motherboard resources
[00000295 - 00000296]	HSMPORT
[000002F8 - 000002FF]	Communications Port (COM2)
[00000376 - 00000376]	Secondary IDE Channel
[00000378 - 0000037F]	Printer Port (LPT1)
[000003B0 - 000003BA]	Advanced Micro Devices Win XP Graphics Driver
[000003C0 - 000003DF]	Advanced Micro Devices Win XP Graphics Driver
[000003F0 - 000003F5]	Standard floppy disk controller
[000003F6 - 000003F6]	Primary IDE Channel
[000003F7 - 000003F7]	Standard floppy disk controller
[000003F8 - 000003FF]	Communications Port (COM1)
[000004D0 - 000004D1]	Motherboard resources
[00000778 - 0000077B]	Printer Port (LPT1)
[00000A78 - 00000A7B]	Motherboard resources
[00000B78 - 00000B7B]	Motherboard resources
[00000BBC - 00000BBF]	Motherboard resources
[00000D00 - 0000AC17]	PCI bus
[00000E78 - 00000E7B]	Motherboard resources
[00000F78 - 00000F7B]	Motherboard resources
[00000FBC - 00000FBF]	Motherboard resources
[0000AC20 - 0000FFFF]	PCI bus
[0000F800 - 0000F8FF]	Realtek RTL8139 Family PCI Fast Ethernet NIC #2
[0000FA00 - 0000FAFF]	Realtek RTL8139 Family PCI Fast Ethernet NIC
[0000FC00 - 0000FCFF]	Ricoh R/RL/RT/RG/5C475(II), R5C520 or Compatible CardBus Controller
[0000FD00 - 0000FDFF]	Ricoh R/RL/RT/RG/5C475(II), R5C520 or Compatible CardBus Controller
[0000FE00 - 0000FE7F]	GEODE - GX2 WDM Audio Driver
[0000FF00 - 0000FF0F]	Standard Dual Channel PCI IDE Controller

---

## B.2 <Memory Address Map>

[00000000 - 0009FFFF]	System board
[000A0000 - 000BFFFF]	Advanced Micro Devices Win XP Graphics Driver
[000A0000 - 000BFFFF]	PCI bus
[000C8000 - 000DFFFF]	PCI bus
[000DF000 - 000DFFFF]	Ricoh R/RL/RT/RC/5C475(II), R5C520 or Compatible CardBus Controller
[000F0000 - 000F3FFF]	System board
[000F4000 - 000F7FFF]	System board
[000F8000 - 000FBFFF]	System board
[000FC000 - 000FFFFF]	System board
[00100000 - 077AFFFF]	System board
[077B0000 - 077BFFFF]	System board
[077C0000 - FEBFFFFF]	PCI bus
[EE000000 - EFFFFFFF]	Advanced Micro Devices Win XP Graphics Driver
[EFFEC000 - EFFFFFFF]	Advanced Micro Devices Win XP Graphics Driver
[EFFF0000 - EFFF3FFF]	Advanced Micro Devices Win XP Graphics Driver
[EFFF4000 - EFFF7FFF]	Advanced Micro Devices Win XP Graphics Driver
† [EFFFA000 - EFFFA0FF]	Realtek RTL8139 Family PCI Fast Ethernet NIC #2
† [EFFF8000 - EFFF80FF]	Realtek RTL8139 Family PCI Fast Ethernet NIC
[EFFF0000 - EFFF0FFF]	Ricoh R/RL/RT/RC/5C475(II), R5C520 or Compatible CardBus Controller
• [EFFFFE00 - EFFFFE00]	Standard OpenHCD USB Host Controller
• [EFFFF000 - EFFFF000]	Standard OpenHCD USB Host Controller
[FABFF000 - FEBFEFFF]	Ricoh R/RL/RT/RC/5C475(II), R5C520 or Compatible CardBus Controller
[FEBFF000 - FEBFFFFF]	Ricoh R/RL/RT/RC/5C475(II), R5C520 or Compatible CardBus Controller
[FEE00000 - FEE00FFF]	System board
[FFFF0000 - FFFFFFFF]	System board

## B.3 <System IRQ & DMA Resources>

### B.3.1 <IRQ>

(ISA) 1	Standard 101/102-Key or Microsoft Natural PS/2 Keyboard
(ISA) 3	Communications Port (COM2)
(ISA) 4	Communications Port (COM1)
(ISA) 6	Standard floppy disk controller
(ISA) 8	System CMOS/real time clock
(ISA) 9	Microsoft ACPI-Compliant System
(ISA) 13	Numeric data processor
(ISA) 14	Primary IDE Channel
(PCI) 5	Ricoh R/RL/RT/RC/5C475(II), R5C520 or Compatible CardBus Controller
(PCI) 5	Standard OpenHCD USB Host Controller
(PCI) 10	GEODE - GX2 WDM Audio Driver
(PCI) 10	Realtek RTL8139 Family PCI Fast Ethernet NIC
(PCI) 11	Realtek RTL8139 Family PCI Fast Ethernet NIC #2
(PCI) 11	Standard OpenHCD USB Host Controller

### B.3.2 <DMA>

- 2 Standard floppy disk controller
- 4 Direct memory access controller



---

Any advice or comments about our products and service, or anything we can help you with please don't hesitate to contact with us. We will do our best to support your products, projects and business.



Address: Global American, Inc.  
17 Hampshire Drive  
Hudson, NH 03051

Telephone: Toll Free U.S. Only (800) 833-8999  
(603) 886-3900

FAX: (603) 886-4545

Website: <http://www.globalamericaninc.com>

Support: Technical Support at Global American

---