

HS-872P(E)

Half-size Single Board Computer User's Manual

Edition: 1.3

2011/10/31



Copyright

Copyright 2007. All rights reserved. This document is copyrighted and all rights are reserved. The information in this document is subject to change without prior notice to make improvements to the products.

This document contains proprietary information and protected by copyright. No part of this document may be reproduced, copied, or translated in any form or any means without prior written permission of the manufacturer.

All trademarks and/or registered trademarks contains in this document are property of their respective owners.

Disclaimer

The company shall not be liable for any incidental or consequential damages resulting from the performance or use of this product.

The company does not issue a warranty of any kind, express or implied, including without limitation implied warranties of merchantability or fitness for a particular purpose.

The company has the right to revise the manual or include changes in the specifications of the product described within it at any time without notice and without obligation to notify any person of such revision or changes.

Trademark

All trademarks are the property of their respective holders.

Any questions please visit our website at <http://www.commell.com.tw>.

Packing List:

Please check the package material before you install the system.

Hardware:

HS-872P(E) Single Board Computer x 1

Cable Kit:

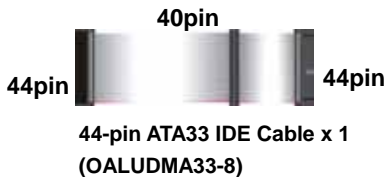

CPU Cooler x 1
(OHS-P-M-3)

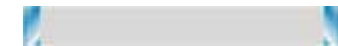

Floppy flat cable x 1
(OALFD/NB)

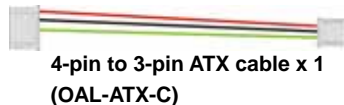

4-pin to 3-pin ATX cable x 1
(OAL-ATX-C)



SATA Cable x 2
(OALSATA-L)

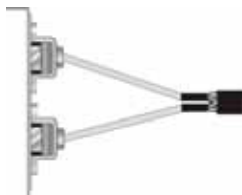

USB cable x 1
(OALUSBA-1)



Audio Port Cable x 1
(OALPJ-N)

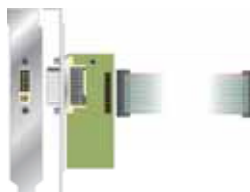

DVI module with DVI cable x 1
(BADP2NDIODVI & OALDVI-P)

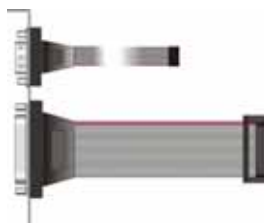
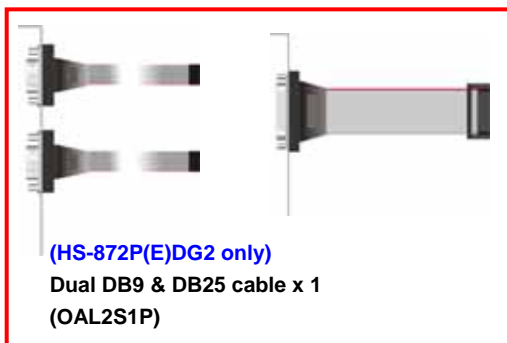

Printed Matters:

Driver CD x 1 (Including User's Manual)

Index

Chapter 1 <Introduction>..... 6

 1.1 <Product Overview> 6

 1.2 <Product Specification> 7

 1.3 < Mechanical Drawing > 9

 1.4 <Block Diagram> 10

Chapter 2 <Hardware Setup> 12

 2.1 <Connector Location> 12

 2.2 <Connector Reference>..... 14

 2.2.1 <Internal Connector> 14

 2.2.2 <External Connector>..... 14

 2.3 <Jumper Reference>..... 15

 2.4 < CPU and Memory Setup > 16

 2.4.1 <CPU Setup> 16

 2.4.2 <Memory Setup> 17

 2.5 <CMOS Setup> 18

 2.6 <Enhanced IDE Interface>..... 19

 2.7 <Serial ATA interface>..... 20

 2.8 <LAN Interface>..... 20

 2.9.1 <Analog VGA Interface> 21

 2.9.2 <Digital Display> 22

 2.9.3 <DVI Interface > 25

 2.9.4<TV-out Interface> 26

 2.10 <Onboard Audio Interface>..... 29

 2.11 <USB2.0 Interface> 30

 2.12 <Serial Port Jumper Setting >..... 32

 2.13 <Power and Fan Installation> 33

 2.13.1 <Power connectors> 33

 2.13.2 <Fan Connectors> 34

2.15 <Switch and Indicator>.....	36
Chapter 3 <System Configuration>	38
3.1 <Video Memory Setup>.....	38
3.2 <Audio Setting>.....	40
Chapter 4 <BIOS Setup>.....	41
(This Page is Left for Blank).....	42
Appendix A <I/O Port Pin Assignment>	43
A.1 IDE Port.....	43
A.2 <Serial ATA Port>.....	43
A.3 < Floppy Port >.....	44
A.4 <Serial Port>.....	44
A.5 <IrDA Port>.....	44
A.6 <VGA Port>.....	45
A.7 <LAN Port>.....	45
A.8 < USB Port >.....	45
A.9 <AT Keyboard Port>.....	46
A.10 <PS/2 Keyboard & Mouse Port>.....	46
Appendix B <Flash BIOS>	48
B1. <BIOS Auto Flash Tool>.....	48
B2. <Flash Method>	48
Appendix C <System Resources>	49
Appendix D <Programming GPIO's>	53
Appendix E <Watch Dog timer Setting >.....	54
Contact Information	56

Chapter 1 <Introduction>

1.1 <Product Overview>

The **HS-872P(E)** is an all-in-one single board computer with PISA bus. with supporting Intel Core 2 Duo / Core Duo / Core solo / Celeron M processor for 533/667MHz front side bus, Intel 945GM(E) and ICH7-M chipset, integrated GMA950 graphics, DDR2 SDRAM memory, Realtek AC97 Audio, Serial ATA and two Intel 82573L Gigabit LAN .

Intel Yonah dual core Processor

The board supports Intel Core 2 Duo / Core Duo / Core Solo / Celeron M processor with 533/667MHz front side bus, 2MB L2 cache, to provide more powerful performance than before.

New features for Intel 945GM(E) chipset

The board integrates Intel 945GM(E) and ICH7-M chipset, to provide new generation of the mobile solution, supports Intel GMA950 graphics, DDR2 533/667 memory, built-in high speed mass storage interface of serial ATA, AC97 Audio with 5.1 channels surrounding sound.

All in One multimedia solution

Based on Intel 945GM(E) and ICH7-M chipset, the board provides high performance onboard graphics, 18-bit Dual channel LVDS interface, DVI and HDTV and 5.1 channels AC97 Audio, to meet the every requirement of the multimedia application.

Flexible Extension Interface

The board also provides Compact Flash Type II socket and one mini-PCI socket.

1.2 <Product Specification>

General Specification

Form Factor	Half-size PISA CPU card
CPU	Intel® Core 2 Duo/ Core Duo/ Core Solo/ Celeron M processor Package type: Micro- FCPGA478 Front side bus: 533/667MHz
Memory	1 x 240-pin DDR2 400/533/667MHz SDRAM up to 2GB Unbuffered, none-ECC memory supported only
Chipset	Intel® 945GM(E) and ICH7-M
BIOS	Phoenix-Award v6.00PG 4Mb PnP flash BIOS
Green Function	Power saving mode includes doze, standby and suspend modes. ACPI version 1.0 and APM version 1.2 compliant
Watchdog Timer	System reset programmable watchdog timer with 1 ~ 255 sec./min. of timeout value
Real Time Clock	Intel® ICH7-M built-in RTC with lithium battery
Enhanced IDE	UltraATA33 IDE interface supports up to 2 ATAPI devices One 44-pin IDE port onboard One CompactFlash Type II socket on solder side
Serial ATA	Intel® ICH7-M integrates 2 Serial ATA interfaces (No RAID Function)Up to 150MB/s of transfer rate

Multi-I/O Port

Chipset	Intel® ICH7-M with Winbond® W83627THG controller
Serial Port	One RS232 and one jumper selectable RS232/422/485
USB Port	4 x Hi-Speed USB 2.0 ports with 480Mbps of transfer rate
Parallel Port	One internal bi-direction parallel port with SPP/ECP/EPP mode
Floppy Port	One internal Floppy port
IrDA Port	One IrDA compliant Infrared interface supports SIR
K/B & Mouse	PS/2 keyboard and mouse port
GPIO	One 12-pin Digital I/O connector with 8-bit programmable
Smart Fan	One CPU fan connectors for fan speed controllable

VGA Display Interface

Chipset	Intel® 945GM(E) GMCH (Graphic Memory Controller Hub)
Memory	Up to 224MB shared with system memory
Display Type	CRT, LCD monitor with analog display, DVI, HDTV
Connector	External DB15 female connector on rear I/O panel Onboard 40-Pin LVDS connector Onboard 26-Pin DVI connector Onboard 9-Pin TV-out connector

Ethernet Interface

Chipset	Intel 82573L Gigabit Ethernet controller
Type	Triple speed 10/100/1000Base-T auto-switching Fast Ethernet Full duplex, IEEE802.3U compliant
Connector	External two RJ45 connectors with LED on rear I/O panel

Solid State Disk Interface

Flash Type	Compact Flash Type II for Compact Flash Card or Micro Drive
------------	---

ISA Interface

ISA Bridge	Winbond W83628G & W83629G
Function	I/O & IRQ supported only, no support DMA & bus mastering

Audio Interface

Chipset	REALTEK ALC655
Interface	5.1 channel surround audio with Line-in, Line-out and MIC-in
Connector	Onboard audio connector with pin header Onboard CD-IN connector

Expansive Interface

Mini PCI	1 x Mini PCI socket
----------	---------------------

Power and Environment

Power Requirement	+5V, +12 DC input & 5V _{SB} Requirement
Dimension	185 (L) x 127 (H) mm
Temperature	Operating within 0 ~ 60°C (32 ~ 140°F) Storage within -20 ~ 85°C (-4 ~ 185°F)

Ordering Code

HS-872P(E)DG	Support Intel Core 2 Duo/Core Duo/Core solo/Celeron M Processor with onboard VGA, DVI, LVDS, Audio, SATA, Giga LAN, USB2.0, Serial port, LPT, CF, GPIO, Mini PCI, FDD,IrDA
HS-872P(E)DG2	Same as above and with secondary Gigabit LAN

The specifications may be different as the actual board.

For further product information please visit the website at <http://www.commell.com.tw>

1.3 < Mechanical Drawing >

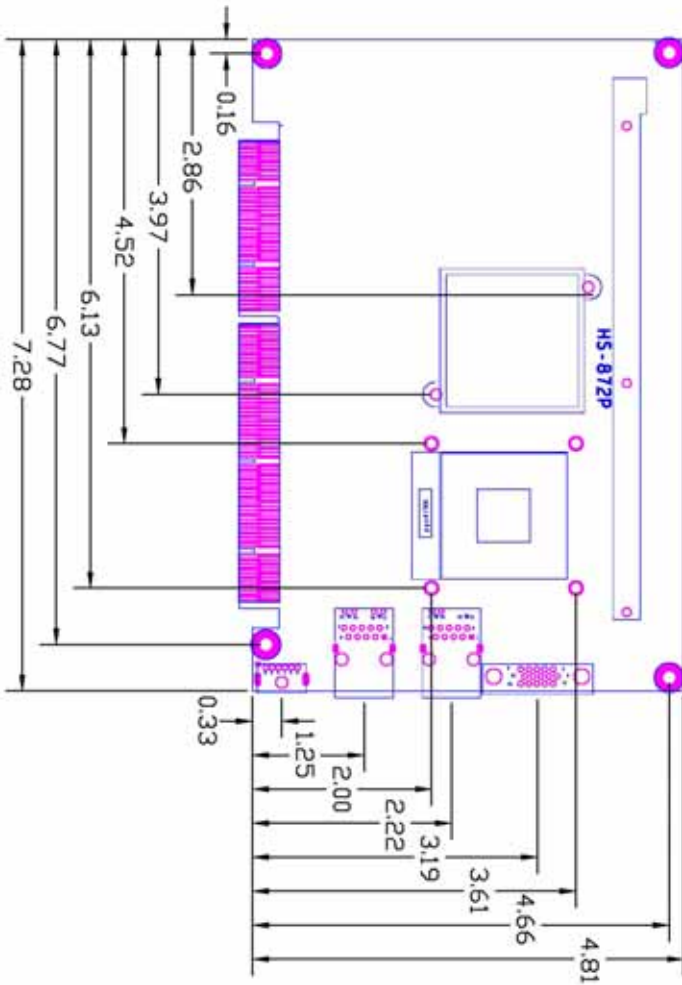

Unit: inch

1.4 <Block Diagram>

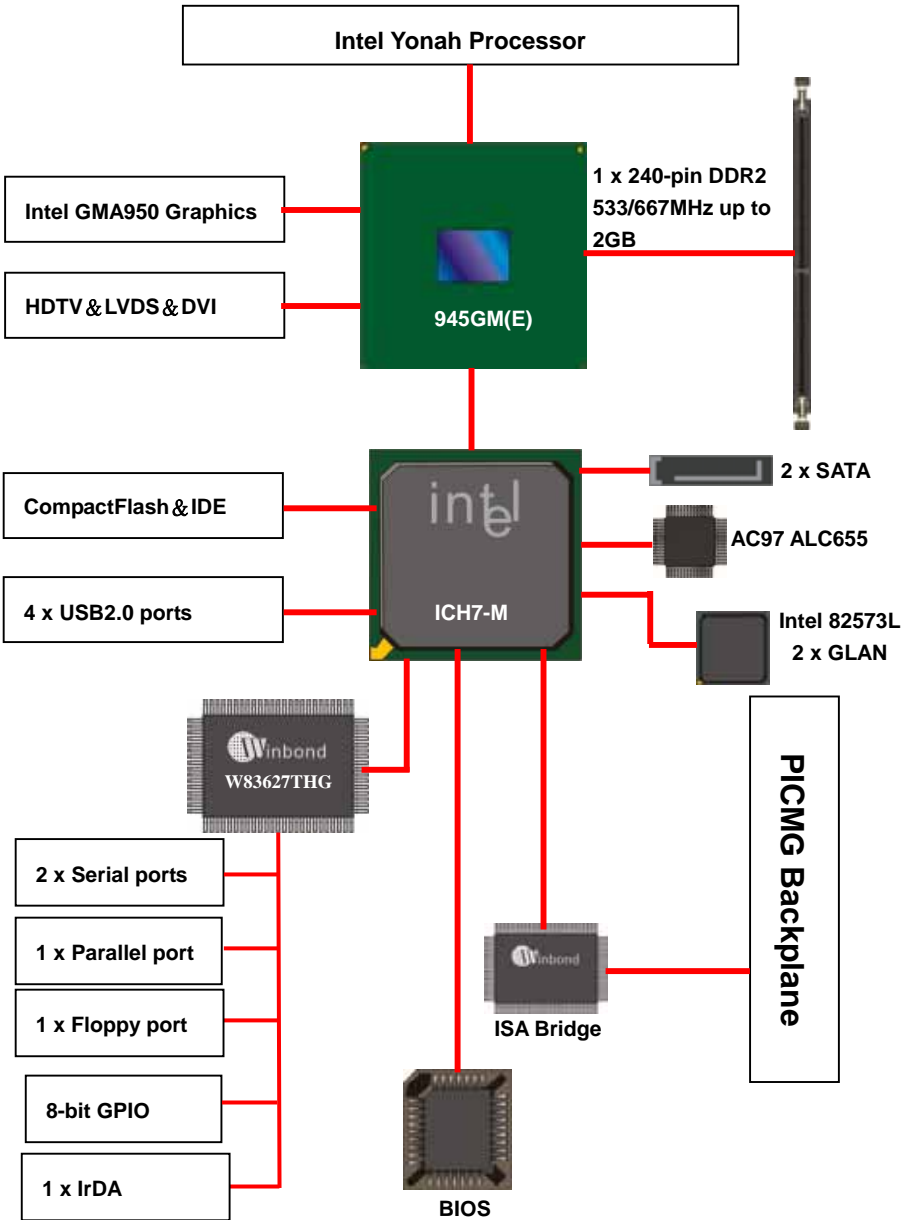

(This Page is Left for Blank)

Chapter 2 <Hardware Setup>

2.1 <Connector Location>

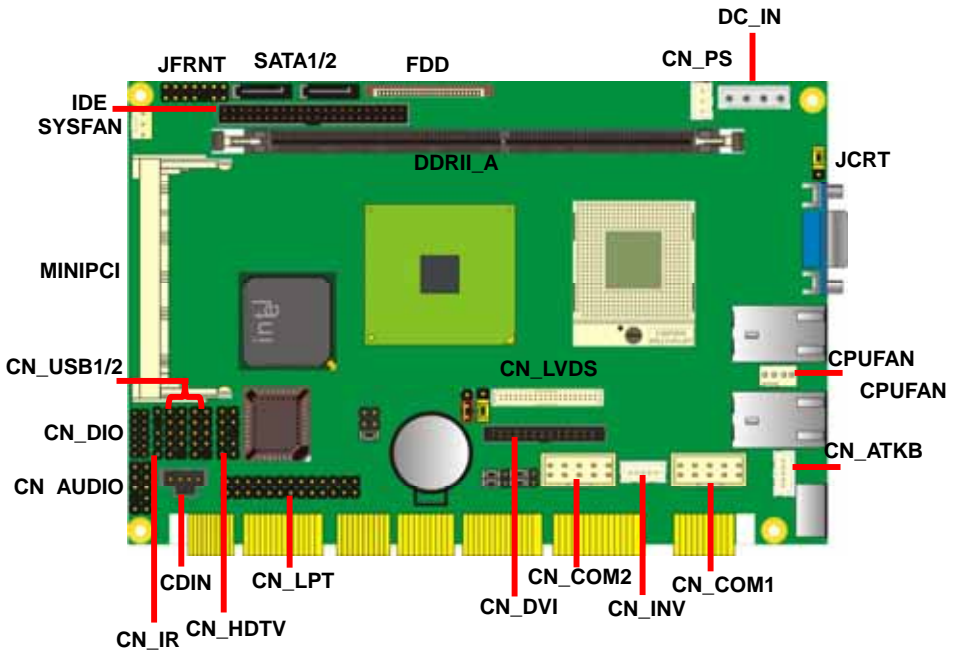

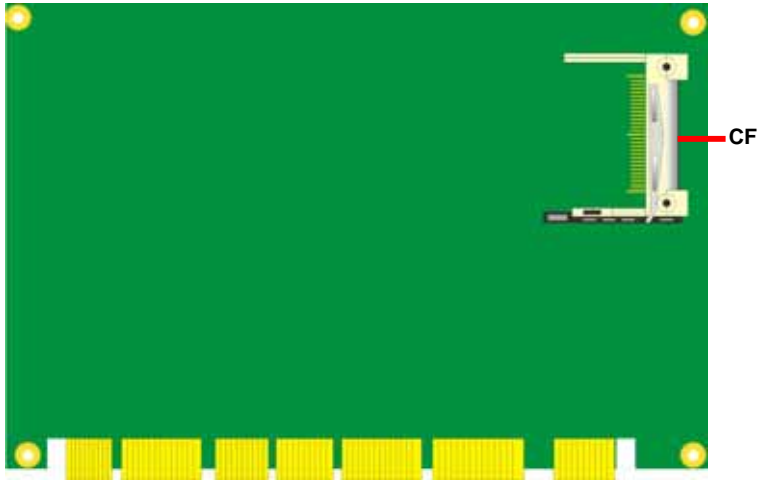

2.2 <Connector Reference>

2.2.1 <Internal Connector>

Connector	Function	Remark
DDRIL_A	240 –pin DDR2 SDRAM DIMM socket	Standard
IDE	44-pin primary IDE connector	Slim
FDD	26-pin floppy connector	Slim
S_ATA1/2	7-pin Serial ATA connector	Standard
DC_IN	4-pin AT power supply connector	Standard
CN_PS	3-pin ATX function connector	Standard
CN_AUDIO	5 x 2-pin audio connector	Standard
CDIN	4-pin CD-ROM audio input connector	Standard
CN_DIO	6 x 2-pin digital I/O connector	Slim
CN_LPT	13 x 2-pin LPT connector	Standard
CN_HDTV	5 x 2-pin HDTV interface	Standard
CN_LVDS	20 x 2-pin LVDS connector	Standard
CN_INV	5-pin LCD inverter connector	Standard
CN_USB1/2	5 x 2-pin USB connector	Standard
CPUFAN	4-pin CPU cooler fan connector	Standard
SYSFAN	3-pin system cooler fan connector	Standard
CN_IR	5-pin IrDA connector	Standard
CN_ATKB	5-pin AT keyboard connector	Standard
CN_DVI	26-pin TMDS connector	Standard
JFRNT	14-pin front panel switch/indicator connector	Standard
CF	Compact Flash TYPE-II socket	Standard
MINIPCI	Mini-PCI socket	Standard
CN_COM1/2	10-pin serial port connector	Standard

2.2.2 <External Connector>

Connector	Function	Remark
CRT	DB15 VGA connector	Standard
RJ45_1/2	One RJ45 LAN connector	Standard
PS2	PS/2 keyboard and mouse connector	Standard

2.3 <Jumper Reference>

Jumper	Function
JRTC	CMOS Operating/Clear Setting
JVLCD	LCD Panel Voltage Setting
JCRT	CRT attach select setting
JCSEL1/2	COM2 RS232/422/485 mode setting

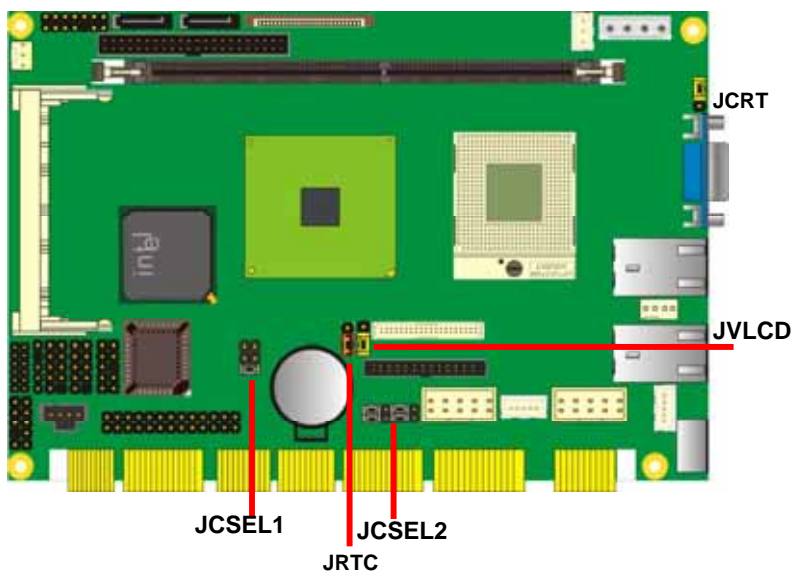

2.4 < CPU and Memory Setup >

2.4.1 <CPU Setup>

The board comes with the socket479 for Intel Core 2 Dual/Core Dual /Core solo processor, it supports new generation of Intel Core 2 Dual/Core Dual /Core solo processor with 533/667MHz of front side bus and 2MB L2 cache. Please follow the instruction to install the CPU properly.

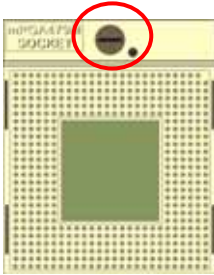

1. Use the flat-type screw drive to unlock the CPU socket

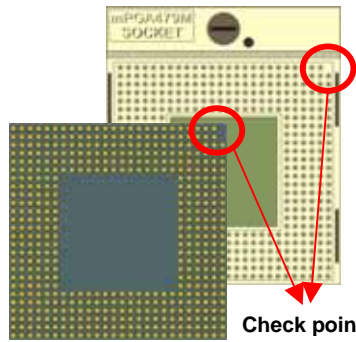

2. Follow the pin direction to install the processor on the socket



3. Lock the socket

2.4.2 <Memory Setup>

HS-872P(E) has one 240-pin DDR2 DIMM support up to 2GB of memory capacity. The memory frequency supports 533/667MHz. Only Non-ECC memory is supported.

Dual-Channel technology is supported while applying two same modules on one of each group.

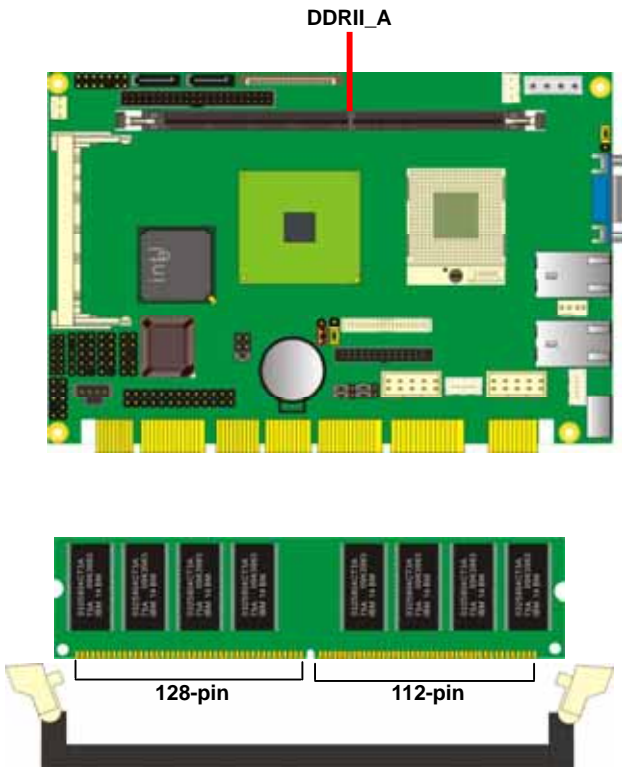

Please check the pin number to match the slot side well before installing memory module.

2.5 <CMOS Setup>

The board's data of CMOS can be setting in BIOS. If the board refuses to boot due to inappropriate CMOS settings, here is how to proceed to clear (reset) the CMOS to its default values.

Jumper: JRTC

Type: Onboard 3-pin jumper

JRTC	Mode
1-2	Clear CMOS
2-3	Normal Operation

Default setting

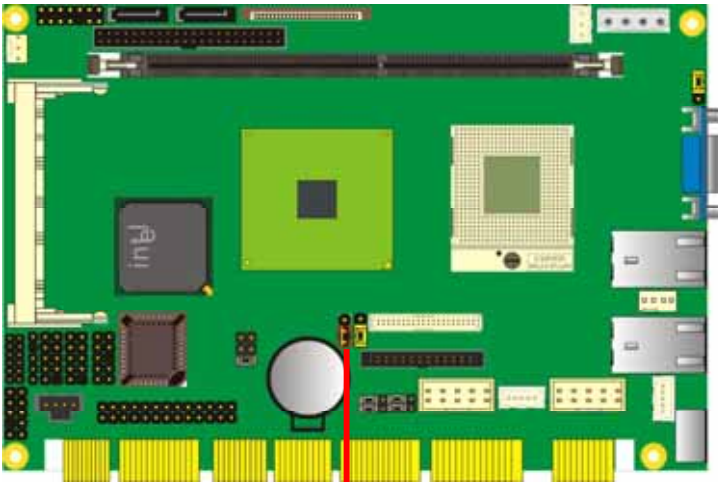

2.6 <Enhanced IDE Interface>

The board has one Ultra ATA33 IDE interface to support up to 2 ATAPI devices, and one Compact Flash Type II socket on the solder side.

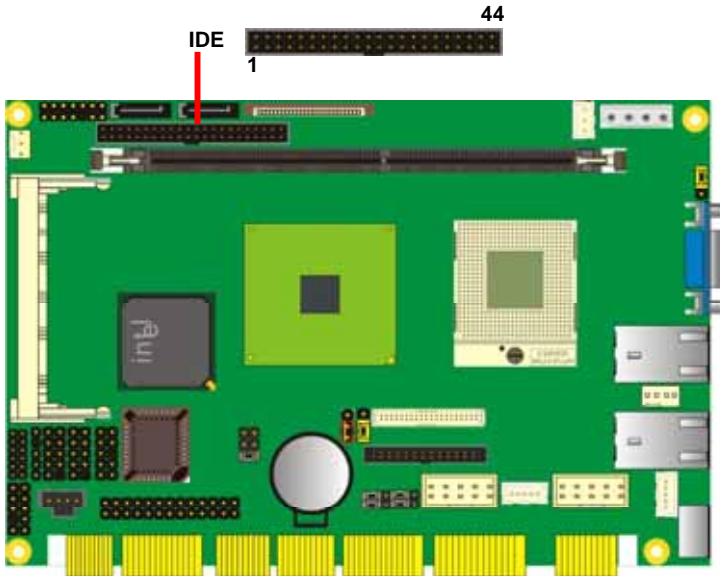

2.7 <Serial ATA interface>

Based on Intel ICH7-M, the board provides two Serial ATA interfaces with up to 150MB/s of transfer rate.

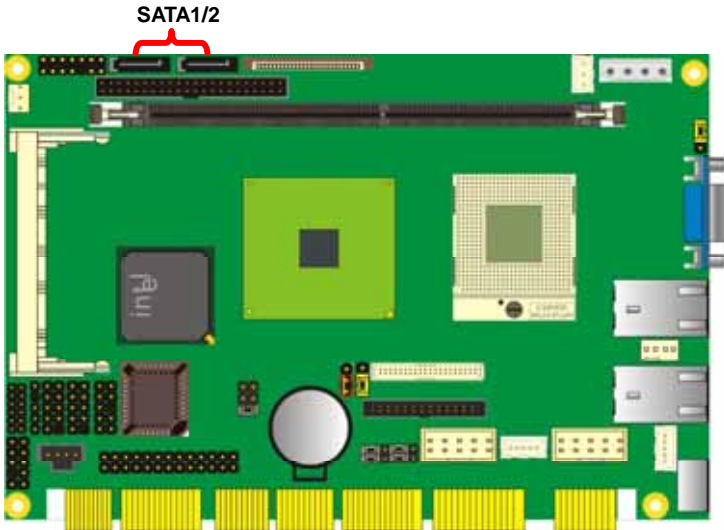

2.8 <LAN Interface>

The Intel 82573L supports triple speed of 10/100/1000Base-T, with IEEE802.3 compliance and Wake-On-LAN supported.

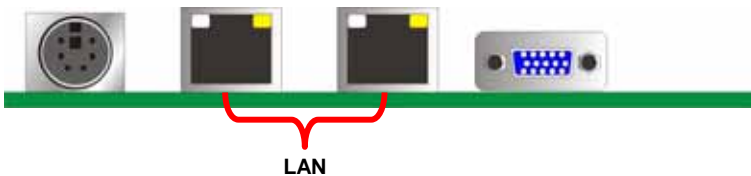

2.9 <Onboard Display Interface>

Based on Intel 945GM(E) chipset with built-in GMA (Graphic Media Accelerator) 950 graphics, the board provides one DB15 connector on real external I/O port, and one 40-pin LVDS interface with 5-pin LCD backlight inverter connector. The board provides dual display function with clone mode and extended desktop mode for CRT and LCD and DVI and TV-out.

2.9.1 <Analog VGA Interface>

Please connect your CRT or LCD monitor with DB15 male connector to the onboard DB15 female connector on rear I/O port.



2.9.2 <Digital Display>

The board provides one 40-pin LVDS connector for 18-bit dual channel panels, supports up to 1600 x 1200 (UXGA) of resolution, with one LCD backlight inverter connector and one jumper for panel voltage setting

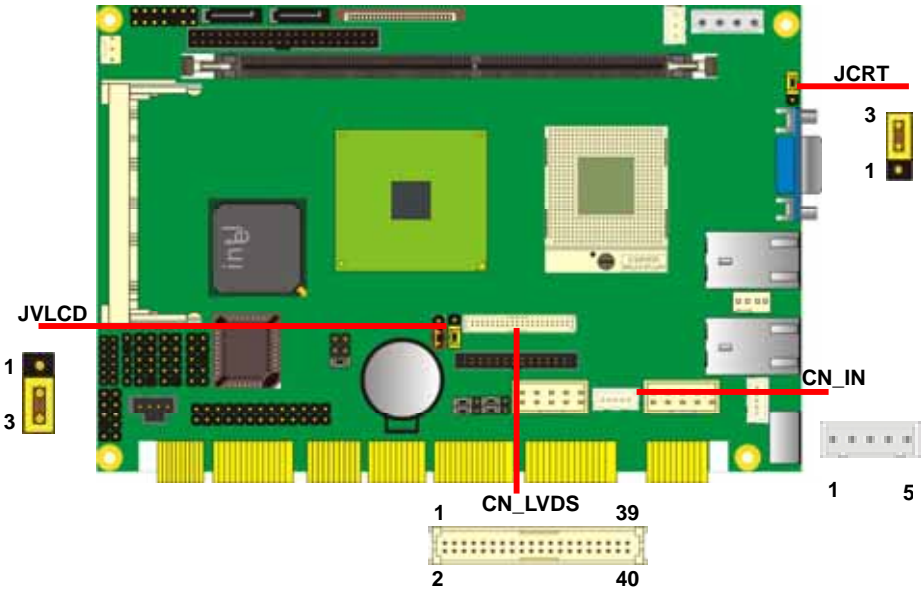

Jumper: **JVRT**

Type: Onboard 3-pin jumper

JVRT	Mode
1-2	CRT always Existence
2-3	By Plug Detect

Default setting

Connector: **CN_INV**

Type: 5-pin LVDS Power Header

Connector model: **JST B5B-XH-A**

Pin	Description
1	+12V
2	GND
3	GND
4	GND
5	ENABKL

Connector: **JVLCD**

Type: 3-pin Power select Header

Pin	Description
1	VCC(5V)
2	LCDVCC
3	VCC3(3.3)

Connector: **CN_LVDS**

Type: onboard 40-pin connector for LVDS connector

Connector model: **HIROSE DF13-40DP-1.25V**

Pin	Signal	Pin	Signal
2	LCDVCC	1	LCDVCC
4	GND	3	GND
6	ATX0-	5	BTX0-
8	ATX0+	7	BTX0+
10	GND	9	GND
12	ATX1-	11	BTX1-
14	ATX1+	13	BTX1+
16	GND	15	GND
18	ATX2-	17	BTX2-
20	ATX2+	19	BTX2+
22	GND	21	GND
24	ACLK-	23	BTX3-
26	ACLK+	25	BTX3+
28	GND	27	GND
30	ATX3-	29	BCLK-
32	ATX3+	31	BCLK+
34	GND	33	GND
36	N/C	35	N/C
38	N/C	37	N/C
40	N/C	39	N/C

To setup the LCD, you need the component below:

1. A panel with LVDS interfaces.
2. An inverter for panel's backlight power.
3. A LCD cable and an inverter cable.

For the cables, please follow the pin assignment of the connector to make a cable, because every panel has its own pin assignment, so we do not provide a standard cable; please find a local cable manufacture to make cables.

LCD Installation Guide:

1. Preparing the **HS-872P(E)**, **LCD panel** and the **backlight inverter**.

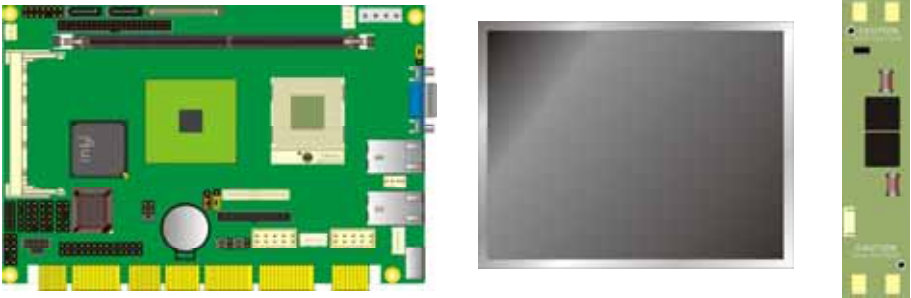

2. Please check the datasheet of the panel to see the voltage of the panel, and set the jumper **JVLCD** to +5V or +3.3V.
3. You would need a LVDS type cable.



4. To connect all of the devices well.

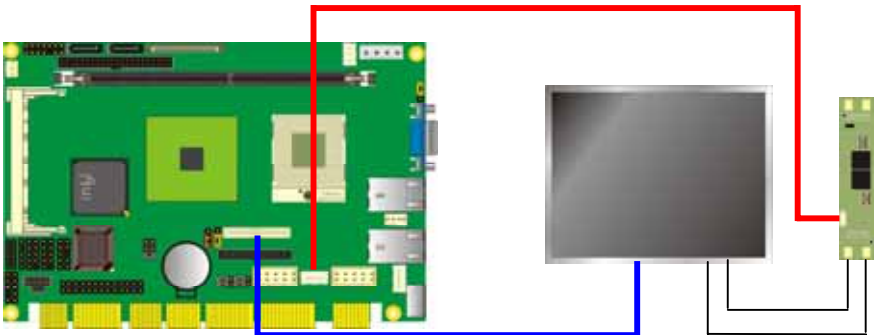

2.9.3 <DVI Interface >

The board also comes with a DVI interface with Chronitel CH7307C for digital video interface.

Connector: **CN_DVI**

Connector type: 26-pin header connector (pitch = 2.00mm)

Pin Number	Assignment	Pin Number	Assignment
1	TX1+	2	TX1-
3	Ground	4	Ground
5	TXC+	6	TXC-
7	Ground	8	PVDD
9	N/C	10	N/C
11	TX2+	12	TX2-
13	Ground	14	Ground
15	TX0+	16	TX0-
17	N/C	18	HPDET
19	DDCDATA	20	DDCCLK
21	GND	22	N/C
23	N/C	24	N/C
25	N/C	26	N/C

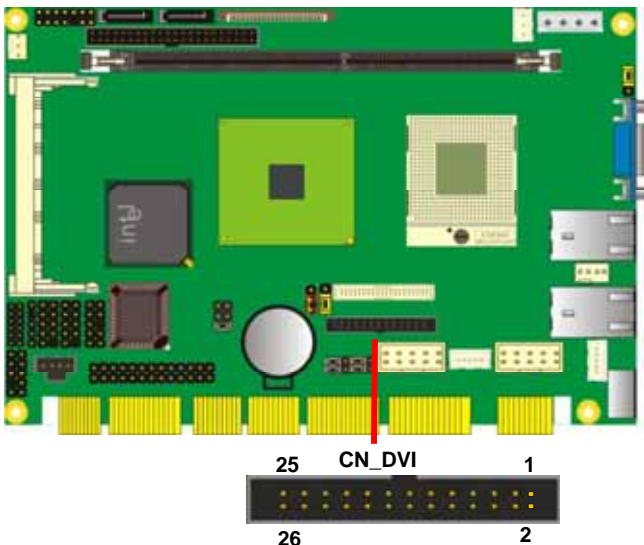

2.9.4<TV-out Interface>

The board provides an HDTV interface with Intel 945GM(E), supports PAL and NTSC of TV system, and display (clone or extended desktop) function with CRT,LVDS,DVI.

Connector: **CN_HDTV**

Connector type: 10-pin header HDTV connector (pitch = 2.54mm)

Pin Number	Assignment	Pin Number	Assignment
1	GND	2	DACB1
3	DACB2	4	GND
5	GND	6	GND
7	DACB3	8	GND
9	N/C	10	+5V

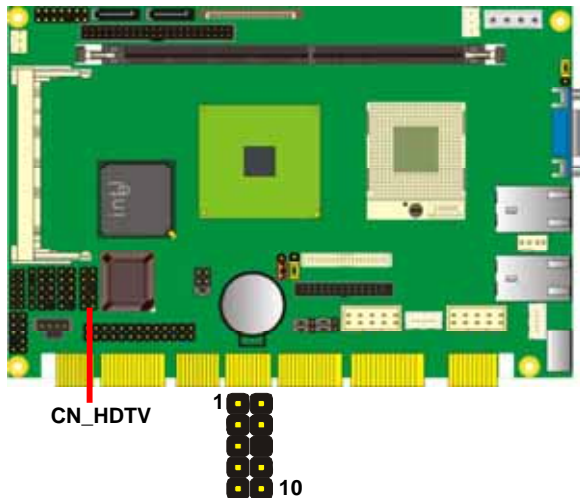

To connect the TV set, please follow the diagram below to setup your system:

YPrPb Component Cable
(For HDTV)

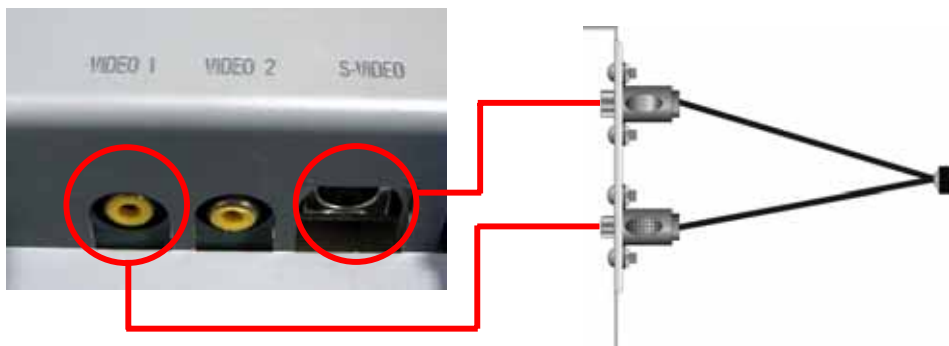
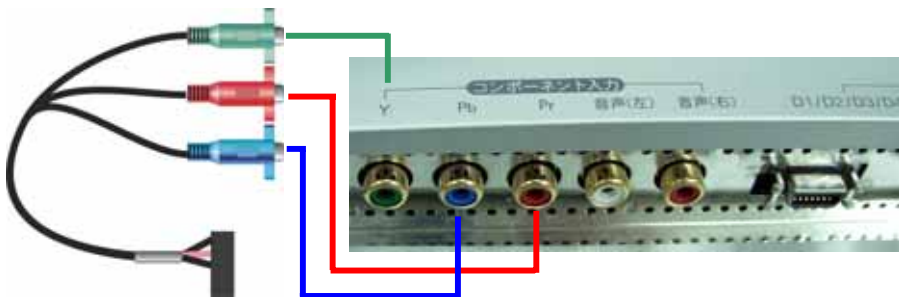
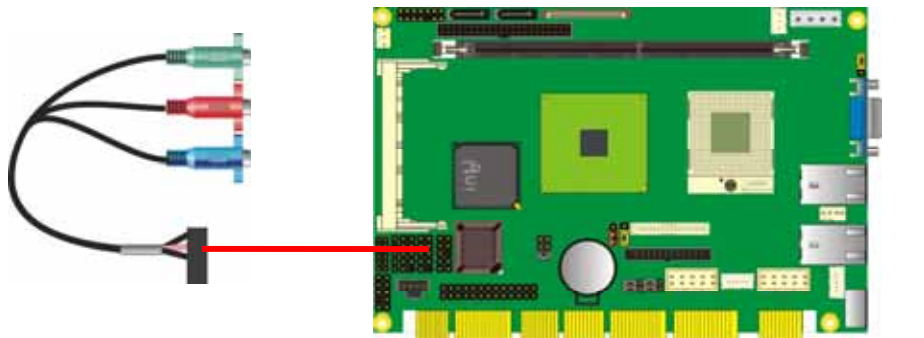

After setup the devices well, you need to select the LCD panel type in the BIOS.



The panel type mapping is list below:

BIOS panel type selection form			
18 bits Single channel		24 bits Dual channel	
NO.	Output format	NO.	Output format
1	640 x 480	9	1024 x 768
2	800 x 600	10	1280 x 768
3	1024 x 768	11	1280 x 1024
24 bits Single channel		12	1366 x 768
4	1280 x 768	13	1400 x 1050 @ 108Mhz
5	1280 x 1024	15	1600 x 1200
6	1366 x 768		
7	1280 x 800		
8	1600 x 1200		
14	1024 x 768		

2.10 <Onboard Audio Interface>

T The board provides the onboard AC97 5.1-channel audio interface with Realtek ALC655

Connector: CN_AUDIO

Type: 10-pin (2 x 5) 1.27mm x 2.54mm-pitch header

Pin	Description	Pin	Description
1	LIN_L	2	Ground
3	LIN_R	4	MIC 2
5	MIC 2	6	Ground
7	N/C	8	FRONTL
9	FRONTR	10	Ground

Connector: CDIN

Type: 4-pin header (pitch = 2.54mm)

Pin	Description
1	CD – Left
2	Ground
3	Ground
4	CD – Right

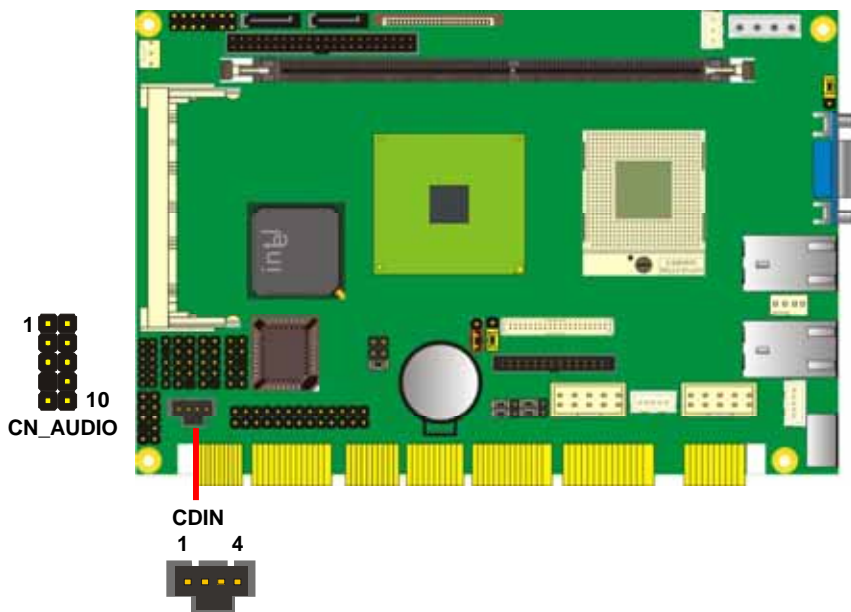

2.11 <USB2.0 Interface>

Based on Intel ICH7-M , the board provides 4 USB2.0 ports. The USB2.0 interface provides up to 480Mbps of transferring rate.

Interface	USB2.0
Controller	ICH7-M
Transfer Rate	Up to 480Mb/s
Output Voltage	500mA

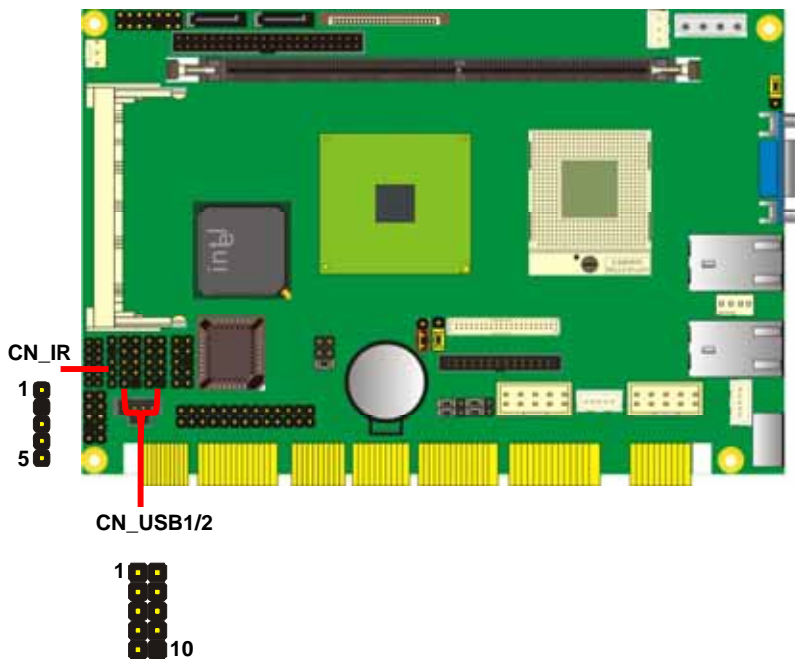

Connector: **CN_IR**

Type: 5-pin header for SIR Port

Pin	Description
1	Vcc
2	N/C
3	IRRX
4	Ground
5	IRTX

Connector: **CN_USB1/2**

Type: 10-pin (5 x 2) header for USB Port

Pin	Description	Pin	Description
1	VCC	2	VCC
3	Data0-	4	Data1-
5	Data0+	6	Data1+
7	Ground	8	Ground
9	Ground	10	N/C

PS: The USB2.0 will be only active when you connecting with the USB2.0 devices, if you insert an USB1.1 device, the port will be changed to USB1.1 protocol automatically. The transferring rate of USB2.0 as 480Mbps is depending on device capacity, exact transferring rate may not be up to 480Mbps.





2.12 <Serial Port Jumper Setting >

The board supports one RS232 serial port and one jumper selectable RS232/422/485 serial ports. The jumper JCSEL1 & JCSEL2 can let you configure the communicating modes for COM2.

Connector: **CN_COM1/2**

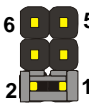
Type: 10-pin (5 x 2) 2.54mm x 2.54mm-pitch header for COM2

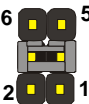
Pin	Description	Pin	Description
1	DCD/422TX-/485-	2	RXD/422TX+/485+
3	TXD/422RX+	4	DTR/422RX-
5	GND	6	DSR
7	RTS	8	CTS
9	RI	10	N/C

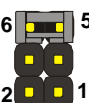
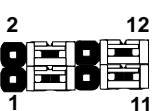
	JCSEL1	JCSEL2
RS-232		
RS-485		
RS-422		

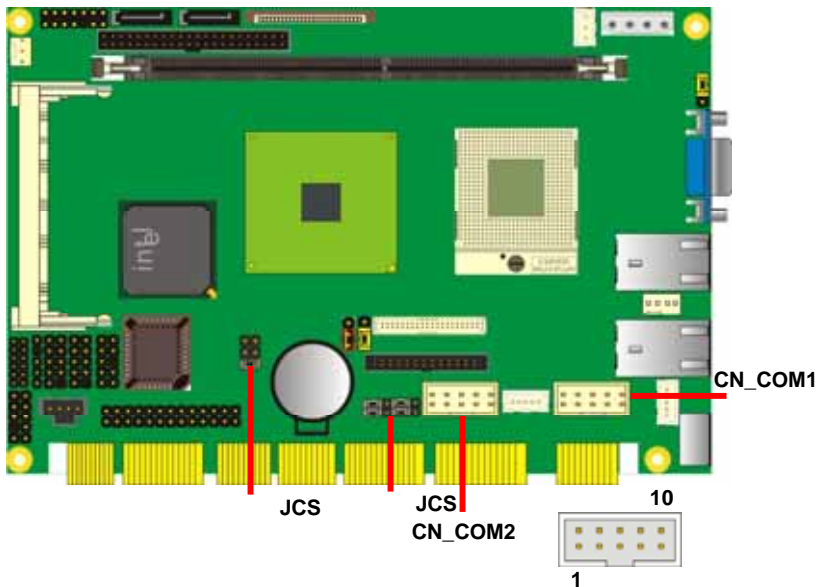

2.13 <Power and Fan Installation>

The board comes with a 4-pin AT power connector for powering the board, three fan connectors for Northbridge, CPU and system. The board also provides a 3-pin ATX function connector. You can just connect the two power connectors without any backplane to work.

2.13.1 <Power connectors>

Connector: **DC_IN**

Type: 4-pin P-type connector for +5V/+12V input

Pin	Description	Pin	Description	Pin	Description	Pin	Description
1	+12V	2	Ground	3	Ground	4	+5V

Connector: **CN_PS**

Type: 3-pin ATX function connector

Pin	Description	Pin	Description	Pin	Description
1	5V Standby	2	Ground	3	Power On

2.13.2 <Fan Connectors>

Connector: **CPUFAN**

Type: 4-pin fan wafer connector

Pin	Description	Pin	Description
1	Ground	2	+12V
3	Fan Speed Detection	4	Fan Control

Connector: **SYSFAN**

Type: 3-pin fan wafer connector

Pin	Description	Pin	Description	Pin	Description
1	Ground	2	+12V	3	Fan Speed Detection

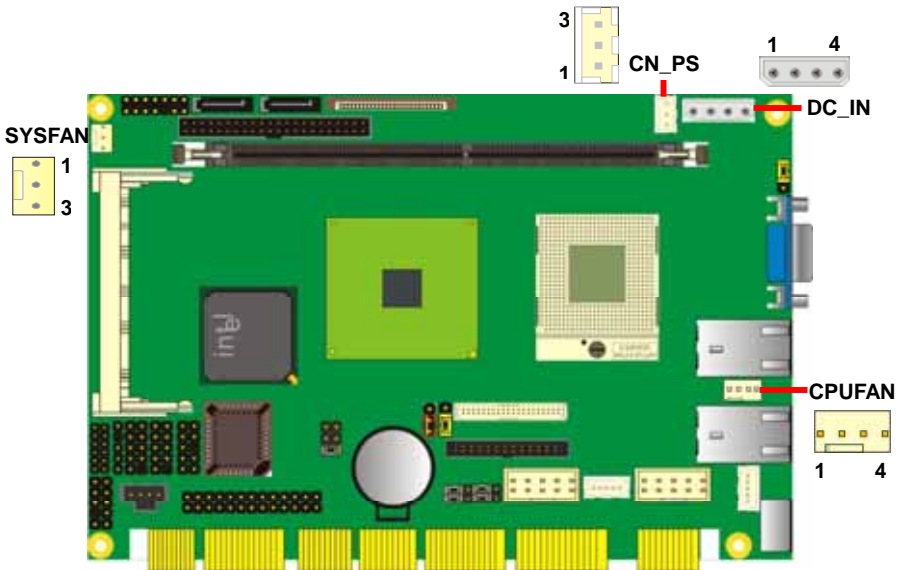

2.14 <GPIO Interface>

The board provides a 12-pin General Purpose I/O interface, with programmable 8-bit I/O (4-bit input & 4-bit output).

Connector: **CN_DIO**

Type: onboard 2 x 6-pin header, pitch=2.0mm

Pin	Description	Pin	Description
1	Ground	2	Ground
3	GP10	4	GP14
5	GP11	6	GP15
7	GP12	8	GP16
9	GP13	10	GP17
11	VCC	12	+12V

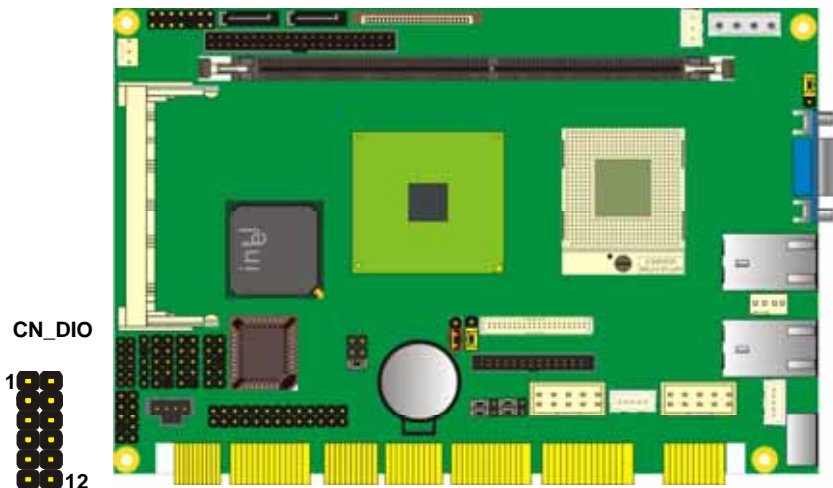

2.15 <Switch and Indicator>

The **JFRNT** provides front control panel of the board, such as power button, reset and beeper, etc. Please check well before you connecting the cables on the chassis.

Connector: **JFRNT**

Type: onboard 14-pin (2 x 7) 2.54-pitch header

Function	Signal	PIN		Signal	Function
IDE LED	Vcc (+)	1	2	(+) Vcc	Power LED
	Active	3	4	N/C	
Reset	Reset	5	6	GND	Speaker
	GND	7	8	Vcc	
N/C		9	10	N/C	
Power	PWRBT	11	12	N/C	
Button	GND	13	14	SPKIN	

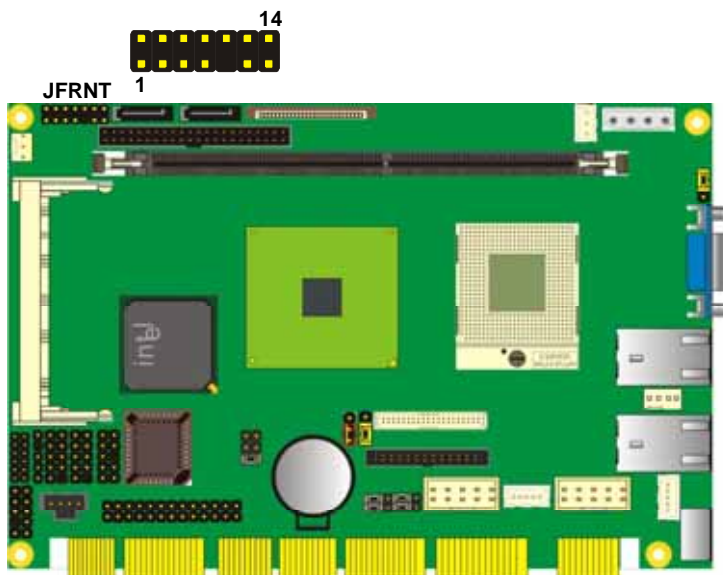

(This Page is Left for Blank)

Chapter 3 <System Configuration>

3.1 <Video Memory Setup>

Based on Intel® 945GM(E) chipset with GMA (Graphic Media Accelerator) 950, the board supports Intel® DVMT (Dynamic Video Memory Technology) 3.0, which would allow the video memory to be allocated up to 224MB.

To support DVMT, you need to install the Intel GMA 950 Driver with supported OS.

BIOS Setup:

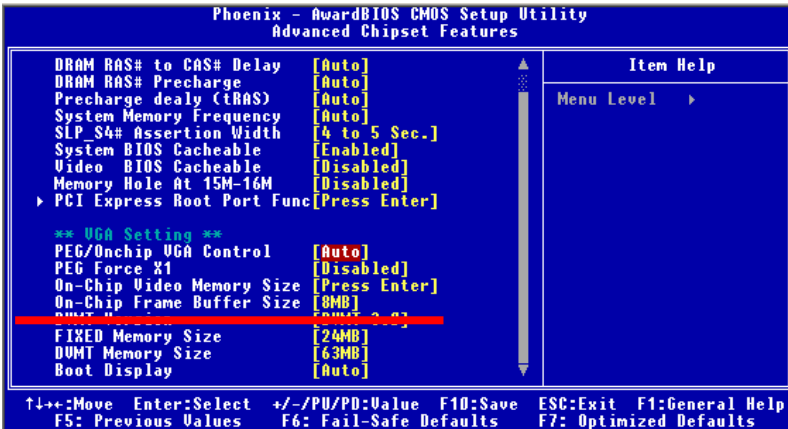

On-Chip Video Memory Size: This option combines three items below for setup.

On-Chip Frame Buffer Size:

This item can let you select video memory which been allocated for legacy VGA and SVGA graphics support and compatibility. The available option is **1MB** and **8MB**.

Fixed Memory Size:

This item can let you select a static amount of page-locked graphics memory which will be allocated during driver initialization. Once you select the memory amount, it will be no longer available for system memory.

DVMT Memory Size:

This item can let you select a maximum size of dynamic amount usage of video memory, the system would configure the video memory depends on your application, this item is strongly recommend to be selected as **MAX DVMT**.

Fixed + DVMT Memory Size:

You can select the fixed amount and the DVMT amount at the same time for a guaranteed video memory and additional dynamic video memory, please check the table below for available setting.

System Memory	On-Chip Frame Buffer Size	Fixed Memory Size	DVMT Memory Size	Total Graphic Memory
128MB~255MB	1MB	32MB	0MB	32MB
	1MB	0MB	32MB	32MB
	8MB	32MB	0MB	32MB
	8MB	0	32MB	32MB
256MB~511MB	1MB	64MB	0MB	64MB
	1MB	0	64MB	64MB
	1MB	128MB	0MB	128MB
	1MB	0	128MB	128MB
	1MB	64MB	64MB	128MB
	8MB	64MB	0MB	64MB
	8MB	0	64MB	64MB
	8MB	128MB	0MB	128MB
	8MB	0	128MB	128MB
	8MB	64MB	64MB	128MB
512MB upper	1MB	64MB	0	64MB
	1MB	0	64MB	64MB
	1MB	128MB	0	128MB
	1MB	0	128MB	128MB
	1MB	64MB	64MB	128MB
	8MB	64MB	0	64MB
	8MB	0	64MB	64MB
	8MB	128MB	0	128MB
	8MB	0	128MB	128MB
8MB	64MB	64MB	128MB	

Notice:

1. The On-Chip Frame Buffer Size would be included in the Fixed Memory.

Please select the memory size according to this table.

3.2 <Audio Setting>

The board integrates Intel® ICH7 with REALTEK® ALC655 codec. It can support 2-channel or 5.1 channel sound under system configuration. Please follow the steps below to setup your sound system.

1. Install REALTEK AC97 Audio driver.



2. Launch the control panel and Sound Effect Manager.
3. Select Speaker Configuration



4. Select the sound mode to meet your speaker system.

Chapter 4 <BIOS Setup>

The motherboard uses the Award BIOS for the system configuration. The Award BIOS in the single board computer is a customized version of the industrial standard BIOS for IBM PC AT-compatible computers. It supports Intel x86 and compatible CPU architecture based processors and computers. The BIOS provides critical low-level support for the system central processing, memory and I/O sub-systems.

The BIOS setup program of the single board computer let the customers modify the basic configuration setting. The settings are stored in a dedicated battery-backed memory, NVRAM, retains the information when the power is turned off. If the battery runs out of the power, then the settings of BIOS will come back to the default setting.

The BIOS section of the manual is subject to change without notice and is provided here for reference purpose only. The settings and configurations of the BIOS are current at the time of print, and therefore they may not be exactly the same as that displayed on your screen.

To activate CMOS Setup program, press key immediately after you turn on the system. The following message "Press DEL to enter SETUP" should appear in the lower left hand corner of your screen. When you enter the CMOS Setup Utility, the Main Menu will be displayed as **Figure 4-1**. You can use arrow keys to select your function, press <Enter> key to accept the selection and enter the sub-menu.

Figure 4-1 CMOS Setup Utility Main Screen

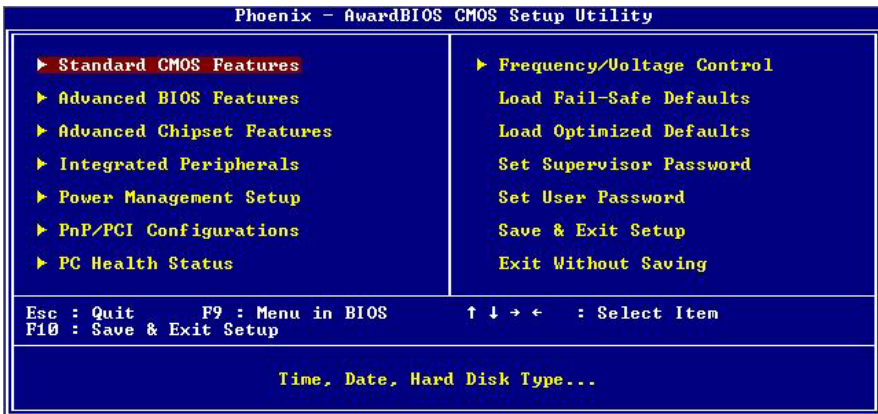

(This Page is Left for Blank)

Appendix A <I/O Port Pin Assignment>

A.1 IDE Port

Connector: **IDE**

Type: 44-pin (22 x 2) box header



Pin	Description	Pin	Description
1	Reset	2	Ground
3	D7	4	D8
5	D6	6	D9
7	D5	8	D10
9	D4	10	D11
11	D3	12	D12
13	D2	14	D13
15	D1	16	D14
17	D0	18	D15
19	Ground	20	N/C
21	REQ	22	Ground
23	-IOW	24	Ground
25	-IOR	26	Ground
27	IORDY	28	Ground
29	DACK	30	Ground
31	IDEIRQ	32	N/C
33	A1	34	66DET
35	A0	36	A2
37	-CS1	38	-CS3
39	-HD LED1	40	Ground
41	+5V	42	+5V
43	Ground	44	Ground

A.2 <Serial ATA Port>

Connector: **SATA1/2**

Type: 7-pin wafer connector

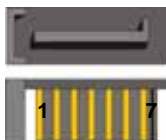

1	2	3	4	5	6	7
GND	RSATA_TXP1	RSATA_TXN1	GND	RSATA_RXN1	RSATA_RXP1	GND

A.3 < Floppy Port >

Connector: **FDD**

Type: 26-pin connector



Pin	Description	Pin	Description
1	VCC	2	INDEX
3	VCC	4	DR0
5	VCC	6	DSKCHG
7	N/C	8	N/C
9	N/C	10	MTR0
11	DRVDE0	12	DIR
13	N/C	14	STEP
15	Ground	16	WRITE DATA
17	Ground	18	WRITE GATE
19	Ground	20	TRAK 0
21	N/C	22	WRPT0
23	Ground	24	RDATA-
25	Ground	26	HDSEL

A.4 <Serial Port>

Connector: **CN_COM1/2**

Type: 10-pin (2 x 5) 2.54-pitch header



Pin	Description	Pin	Description
1	DCD	2	SIN
3	SO	4	DTR
5	Ground	6	DSR
7	RTS	8	CTS
9	RI	10	N/C

A.5 <IrDA Port>

Connector: **CN_IR**

Type: 5-pin header for SIR Ports

Pin	Description
1	VCC
2	N/C
3	IRRX
4	Ground
5	IRTX



A.6 <VGA Port>

Connector: CRT

Type: 15-pin D-sub female connector on bracket

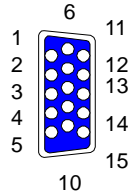

Pin	Description	Pin	Description	Pin	Description
1	RED	6	Ground	11	N/C
2	GREEN	7	Ground	12	5VCCA
3	BLUE	8	Ground	13	HSYNC
4	N/C	9	LVGA5V	14	VSYNC
5	Ground	10	Ground	15	5VCLK

A.7 <LAN Port>

Connector: RJ45_1/2

Type: RJ45 connector with LED on rear panel

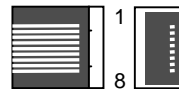

Pin	1	2	3	4	5	6	7	8
Description	TX+	TX-	RX+	N/C	N/C	RX-	N/C	N/C

A.8 < USB Port >

Connector: CN_USB1/2

Type: 10-pin (5 x 2) header for dual USB Ports

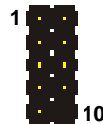

Pin	Description	Pin	Description
1	VCC	2	VCC
3	Data0-	4	Data1-
5	Data0+	6	Data1+
7	Ground	8	Ground
9	Ground	10	N/C

A.9 <AT Keyboard Port>

Connector: CN_ATKB

Type: 5-pin box header

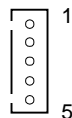

Pin	1	2	3	4	5
Description	VCC	Ground	N/C	DATA	CLK

A.10 <PS/2 Keyboard & Mouse Port>

Connector: PS2

Type: 6-pin Mini-DIN connector on bracket

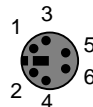

Pin	1	2	3	4	5	6
Description	KBD	MSD	Ground	VCC	KBC	MSC

Note: The PS/2 connector supports standard PS/2 keyboard directly or both PS/2 keyboard and mouse through the PS/2 Y-type cable.

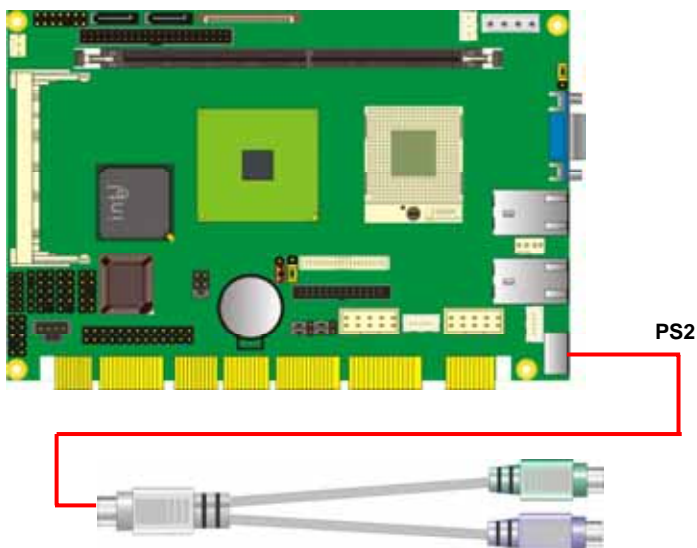

(This Page is Left for Blank)

Appendix B <Flash BIOS>

B1. <BIOS Auto Flash Tool>

The board is based on Award BIOS and can be updated easily by the BIOS auto flash tool. You can download the tool online at the address below:

<http://www.award.com>

<http://www.commell.com.tw/support/support.htm>

File name of the tool is "awdf flash.exe", it's the utility that can write the data into the BIOS flash chip and update the BIOS.

B2. <Flash Method>

1. Please make a bootable floppy disk.
2. Get the last .bin files you want to update and copy it into the disk.
3. Copy awardflash.exe to the disk.
4. Power on the system and flash the BIOS. (Example: C:/ awardflash XXX.bin)
5. Re-start the system.

Any question about the BIOS re-flash please contact your distributors or visit the web-site at below:

<http://www.commell.com.tw/support/support.htm>

Appendix C <System Resources>

C1.<I/O Port Address Map>

[00000000 - 00000CF7]	PCI bus
[00000000 - 0000000F]	Direct memory access controller
[00000010 - 0000001F]	Motherboard resources
[00000020 - 00000021]	Programmable interrupt controller
[00000022 - 0000003F]	Motherboard resources
[00000040 - 00000043]	System timer
[00000044 - 0000005F]	Motherboard resources
[00000060 - 00000060]	Standard 101/102-Key or Microsoft Natural PS/2 Keyboard
[00000061 - 00000061]	System speaker
[00000062 - 00000063]	Motherboard resources
[00000064 - 00000064]	Standard 101/102-Key or Microsoft Natural PS/2 Keyboard
[00000065 - 0000006F]	Motherboard resources
[00000070 - 00000073]	System CMOS/real time clock
[00000074 - 0000007F]	Motherboard resources
[00000080 - 00000090]	Direct memory access controller
[00000091 - 00000093]	Motherboard resources
[00000094 - 0000009F]	Direct memory access controller
[000000A0 - 000000A1]	Programmable interrupt controller
[000000A2 - 000000BF]	Motherboard resources
[000000C0 - 000000DF]	Direct memory access controller
[000000E0 - 000000EF]	Motherboard resources
[000000F0 - 000000FF]	Numeric data processor
[00000170 - 00000177]	Secondary IDE Channel
[000001F0 - 000001F7]	Primary IDE Channel
[00000200 - 00000200]	Standard Game Port
[00000201 - 00000207]	Standard Game Port
[00000274 - 00000277]	ISAPNP Read Data Port
[00000279 - 00000279]	ISAPNP Read Data Port
[000002F8 - 000002FF]	Communications Port (COM2)
[00000376 - 00000376]	Secondary IDE Channel
[00000378 - 0000037F]	Printer Port (LPT1)
[000003B0 - 000003BB]	Mobile Intel(R) 945GM Express Chipset Family
[000003C0 - 000003DF]	Mobile Intel(R) 945GM Express Chipset Family
[000003F0 - 000003F5]	Standard floppy disk controller
[000003F6 - 000003F6]	Primary IDE Channel

[000003F7 - 000003F7]	Standard floppy disk controller
[000003F8 - 000003FF]	Communications Port (COM1)
[00000400 - 000004BF]	Motherboard resources
[000004D0 - 000004D1]	Motherboard resources
[00000500 - 0000051F]	Intel(R) 82801G (ICH7 Family) SMBus Controller - 27DA
[00000778 - 0000077B]	Printer Port (LPT1)
[00000800 - 0000087F]	Motherboard resources
[00000880 - 0000088F]	Motherboard resources
[00000A79 - 00000A79]	ISAPNP Read Data Port
[00000D00 - 0000FFFF]	PCI bus
[0000A000 - 0000AFFF]	Intel(R) 82801G (ICH7 Family) PCI Express Root Port - 27D0
[0000B000 - 0000BFFF]	Intel(R) 82801G (ICH7 Family) PCI Express Root Port - 27D6
[0000BF00 - 0000BF1F]	Intel(R) PRO/1000 PL Network Connection #2
[0000C000 - 0000CFFF]	Intel(R) 82801G (ICH7 Family) PCI Express Root Port - 27D4
[0000CF00 - 0000CF1F]	Intel(R) PRO/1000 PL Network Connection
[0000F000 - 0000FOFF]	Realtek AC'97 Audio
[0000F800 - 0000F80F]	Intel(R) 82801G (ICH7 Family) Ultra ATA Storage Controllers - 27DF
[0000FA00 - 0000FA3F]	Realtek AC'97 Audio
[0000FB00 - 0000FB1F]	Intel(R) 82801G (ICH7 Family) USB Universal Host Controller - 27CB
[0000FC00 - 0000FC1F]	Intel(R) 82801G (ICH7 Family) USB Universal Host Controller - 27CA
[0000FD00 - 0000FD1F]	Intel(R) 82801G (ICH7 Family) USB Universal Host Controller - 27C9
[0000FE00 - 0000FE1F]	Intel(R) 82801G (ICH7 Family) USB Universal Host Controller - 27C8
[0000FF00 - 0000FF07]	Mobile Intel(R) 945GM Express Chipset Family

C2.<Memory Address Map>

[00000000 - 0009FFFF]	System board
[000A0000 - 000BFFFF]	PCI bus
[000A0000 - 000BFFFF]	Mobile Intel(R) 945GM Express Chipset Family
[000C0000 - 000DFFFF]	PCI bus
[000E0000 - 000EFFFF]	System board
[000F0000 - 000F7FFF]	System board
[000F8000 - 000FBFFF]	System board
[000FC000 - 000FFFFF]	System board
[00100000 - 3F6DFFFF]	System board
[00636500 - 00D1CCFF]	System board
[3F6E0000 - 3F6FFFFF]	System board
[3F700000 - FEBFFFFF]	PCI bus
[D0000000 - DFFFFFFF]	Mobile Intel(R) 945GM Express Chipset Family
[E0000000 - EFFFFFFF]	Motherboard resources
[FD600000 - FD6FFFFF]	Intel(R) 82801G (ICH7 Family) PCI Express Root Port - 27D4
[FD700000 - FD7FFFFF]	Intel(R) 82801G (ICH7 Family) PCI Express Root Port - 27D4
[FD7E0000 - FD7FFFFF]	Intel(R) PRO/1000 PL Network Connection
[FD800000 - FD8FFFFF]	Intel(R) 82801G (ICH7 Family) PCI Express Root Port - 27D0
[FDB00000 - FDBFFFFF]	Intel(R) 82801G (ICH7 Family) PCI Express Root Port - 27D0
[FDC00000 - FDCFFFFF]	Intel(R) 82801G (ICH7 Family) PCI Express Root Port - 27D6
[FDD00000 - FDDFFFFF]	Intel(R) 82801G (ICH7 Family) PCI Express Root Port - 27D6
[FDDE0000 - FDDFFFFF]	Intel(R) PRO/1000 PL Network Connection #2
[FDE80000 - FDEFFFFF]	Mobile Intel(R) 945GM Express Chipset Family
[FDF00000 - FDF7FFFF]	Mobile Intel(R) 945GM Express Chipset Family
[FDF80000 - FDFBFFFF]	Mobile Intel(R) 945GM Express Chipset Family
[FDFFD000 - FDFFD0FF]	Realtek AC'97 Audio
[FDFFE000 - FDFFE1FF]	Realtek AC'97 Audio
[FDFFF000 - FDFFF3FF]	Universal Serial Bus (USB) Controller
[FEC00000 - FEC00FFF]	System board
[FED13000 - FED1DFFF]	System board
[FED20000 - FED8FFFF]	System board
[FEE00000 - FEE00FFF]	System board
[FFB00000 - FFB7FFFF]	System board
[FFB80000 - FFBFFFFF]	Intel(r) 82802 Firmware Hub Device
[FFF00000 - FFFFFFFF]	System board

C3.<System IRQ Resources>

(ISA) 0	System timer
(ISA) 1	Standard 101/102-Key or Microsoft Natural PS/2 Keyboard
(ISA) 3	Communications Port (COM2)
(ISA) 4	Communications Port (COM1)
(ISA) 6	Standard floppy disk controller
(ISA) 8	System CMOS/real time clock
(ISA) 9	Microsoft ACPI-Compliant System
(ISA) 13	Numeric data processor
(ISA) 14	Primary IDE Channel
(ISA) 15	Secondary IDE Channel
(PCI) 10	Universal Serial Bus (USB) Controller
(PCI) 11	Intel(R) 82801G (ICH7 Family) SMBus Controller - 27DA
(PCI) 16	Intel(R) 82801G (ICH7 Family) PCI Express Root Port - 27D0
(PCI) 16	Intel(R) 82801G (ICH7 Family) USB Universal Host Controller - 27CB
(PCI) 16	Mobile Intel(R) 945GM Express Chipset Family
(PCI) 17	Realtek AC'97 Audio
(PCI) 18	Intel(R) 82801G (ICH7 Family) PCI Express Root Port - 27D4
(PCI) 18	Intel(R) 82801G (ICH7 Family) USB Universal Host Controller - 27CA
(PCI) 18	Intel(R) PRO/1000 PL Network Connection
(PCI) 19	Intel(R) 82801G (ICH7 Family) PCI Express Root Port - 27D6
(PCI) 19	Intel(R) 82801G (ICH7 Family) USB Universal Host Controller - 27C9
(PCI) 19	Intel(R) PRO/1000 PL Network Connection #2
(PCI) 23	Intel(R) 82801G (ICH7 Family) USB Universal Host Controller - 27C8

Appendix D <Programming GPIO's>

The GPIO can be programmed with the MSDOS debug program using simple

IN/OUT commands. The following lines show an example how to do this.

GPIO0...GPIO7 bit0.....bit7

```
-o 4E 87                ;enter configuration
-o 4E 87
-o 4E 2A
-o 4F FD                ;enable GPIO function
-o 4E 07
-o 4F 07                ;enable GPIO configuration
-o 4E F0
-o 4F xx                ;set GPIO as input/output; set '1' for input,'0'for output
-o 4E F1
-o 4F xx                ;if set GPIO's as output, in this register its value can be
set
```

Optional :

```
-o 4E F2
-o 4F xx                ; Data inversion register ; '1' inverts the current value of
the bits ,'0' leaves them as they are
-o 4E 30
-o 4F 01                ; active GPIO's
```

For further information ,please refer to Winbond W83627THG datasheet.

Appendix E <Watch Dog timer Setting >

The watchdog timer makes the system auto-reset while it stops to work for a period. The integrated watchdog timer can be setup as system reset mode by program.

Timeout Value Range

- 1 to 255
- Second or Minute

Program Sample

Watchdog timer setup as system reset with 5 second of timeout

```

2E, 87
2E, 87
2E, 07
2F, 08      Logical Device 8
2E, 30      Activate
2F, 01
2E, F5      Set as Second*
2F, 00
2E, F6      Set as 5
2F, 05

```

* Minute: bit 3 = 0; Second: bit 3 = 1

You can select Timer setting in the BIOS, after setting the time options, the system will reset according to the period of your selection.



(This Page is Left for Blank)

Contact Information

Any advice or comment about our products and service, or anything we can help you please don't hesitate to contact with us. We will do our best to support you for your products, projects and business

Taiwan Commate Computer Inc.

Address	19F., No.94, Sec. 1, Xintai 5th Rd., Xizhi Dist., New Taipei City 22102, Taiwan
TEL	+886-2-26963909
FAX	+886-2-26963911
Website	http://www.commell.com.tw
E-Mail	info@commell.com.tw (General Information) tech@commell.com.tw (Technical Support)

Commell is our trademark of industrial PC division