



integration with integrity

3307830 User's Manual

**5.25" Embedded Controller with Socket P for
Intel Core 2 Duo / Celeron Mobile Processors**

Version 1.21 - 10/24/2008

Copyrights

This document is copyrighted and all rights are reserved. It does not allow any non authorization in copied, photocopied, translated or reproduced to any electronic or machine readable form in whole or in part without prior written consent from the manufacturer.

In general, the manufacturer will not be liable for any direct, indirect, special, incidental or consequential damages arising from the use of inability to use the product or documentation, even if advised of the possibility of such damages. The manufacturer keeps the rights in the subject to change the contents of this document without prior notices in order to improve the function design, performance, quality and reliability. The author assumes no responsibility for any errors or omissions, which may appear in this document, nor does it make a commitment to update the information contained herein.

Trademarks

Intel is a registered trademark of Intel Corporation.

Award is a registered trademark of Award Software, Inc.

All other trademarks, products and or product's name mentioned herein are mentioned for identification purposes only, and may be trademarks and/or registered trademarks of their respective companies or owners.

Packing List:

Please check the package content before you starting using the board.

Hardware:

3307830 Embedded Miniboard x 1

Cable Kit:



ATA33 IDE Cable x1



Floppy Cable x 1



SATA Cable x 2



Printer Port Cable x 1

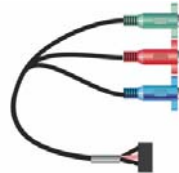

YPbPr Cable x 1

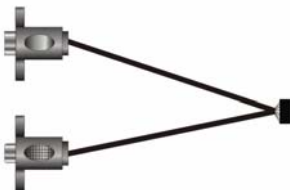

SDTV Cable x 1



USB Cable x 2

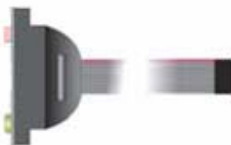

HD Audio Port Cable x 1



COM port Cable x 2



LAN Connector x1 & LAN Cable x 2



Quad COM ports DB9 male Cable x 1

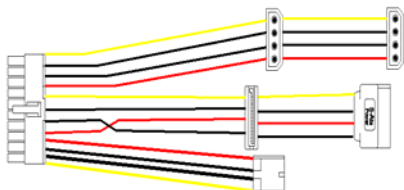

ATX Power Output Cable x 1



CPU Cooler x 1



DC Power Cable x 1

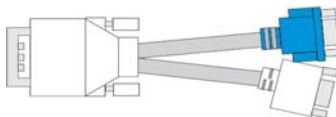

DVI VGA Cable x 1



DVI module with DVI Cable x 1
(TXD · TX2D · TX2 Series)

DVI module with DVI Cable x 2
(TXD2 · T2X Series)



DVI to VGA module x1

DVI to VGA module x2

Printed Matters:

Driver CD x 1 (Including User's Manual)

Index

Chapter 1 <Introduction>	7
1.1 <Product Overview>.....	7
1.2 <Product Specification>	8
1.3 <Mechanical Drawing>	10
1.4 <Block Diagram>	11
Chapter 2 <Hardware Setup>	12
2.1 <Connector Location>	12
2.2 <Jumper Location & Reference>.....	13
2.3 <Connector Reference>	15
2.3.1 <Internal Connectors>	15
2.4 <CPU and Memory Setup>	16
2.4.1 <CPU Setup>	16
2.4.2 <Memory Setup>	17
2.5 <CMOS Setup>	18
2.6 <Enhanced IDE Interface>	19
2.7 <Serial ATA Interface>	20
2.8 <Floppy Port>.....	21
2.9 <Ethernet Interface>	22
2.10 <Onboard Display Interface>	23
2.10.1 <Digital Display>	24
2.10.2 <HDTV Interface>.....	28
2.11 <Integrated Audio Interface>.....	29
2.12 <GPIO Interface>	31
2.13 <Power Supply>	32
2.13.1.1 <DC_IN Input>.....	32
2.13.1.2 <ATX Output>	33
2.13.2 <ATX Power Mode>	34

2.14 <Switch and Indicator>.....	35
Chapter 3 <System Setup>.....	36
3.1 <Audio Configuration>	36
3.2 <Video Memory Setup>	37
3.3 <Display Properties Setting>.....	38
Appendix A <I/O Port Pin Assignment>	42
A.1 <IDE Port>.....	42
A.2 <Serial ATA Port>	43
A.3 <Floppy Port>	43
A.4 <IrDA Port>	43
A.5 <SMBUS Port>.....	44
A.6 <Serial Port 1>	44
A.7 <Serial Port 2>	44
A.8 <Parallel Port>	46
A.9 <LAN Port>	46
A.10 <USB Interface>	47
A.11 <COM3/4/5/6 Port>	47
A.12 <DVI Port>	48
Appendix B <System Resources>.....	50
Appendix C <Programming GPIO's>.....	54
Appendix D <Programming Watchdog Timer>.....	55
Contact Information	56

(This page is left for blank)

Chapter 1 <Introduction>

1.1 <Product Overview>

3307830, the new generation of the 5.25" Miniboard, supports Intel Merom Processors for 533/667/800MHz front side bus and features Intel GM(E)965 and ICH8M chipset, integrated GMA X3100 graphics, DDR2 memory, REALTEK High Definition Audio, Serial ATA and two Intel Gigabit LAN.

Intel Merom Processor

The board supports Intel Core 2 Duo/Celeron M **socket-P** processor with 533/667/800MHz front side bus, L2 Cache: All specification depend on the CPU. (1M/2M/3M/4M/6M) , to provide more powerful performance than before.

New features for Intel GM(E)965 chipset

The board integrates Intel GM(E)965 and ICH8M chipset, to provide new generation of the mobile solution, supports Intel GMA X3100 graphics, DDR2 533/667MHz memory, built-in high speed mass storage interface of serial ATA, High Definition Audio with 2 channels surrounding sound.

All in One multimedia solution

Based on Intel GM(E)965 and ICH8M chipset, the board provides high performance onboard graphics, 24-bit dual channel LVDS interface, HDTV and 2 channels High Definition Audio, to meet the very requirement of the multimedia application.

Flexible Extension Interface

The board provides Compact Flash Type II socket, two mini-PCI socket and one PCI slot.

1.2 <Product Specification>

General Specification

Form Factor	5.25 Inches Embedded Miniboard
CPU	Support Intel Core 2 Duo/Celeron M Mobile Processor Package type: Micro-FCPGA478 (Socket-P) L2 Cache: All specification depend on the CPU. (1M/2M/3M/4M/6M) Front side bus: 533/667/800 MHz
Memory	One 533/667MHz DDRII 200-pin SO-DIMM up to 2GB
Onboard Memory	Optional onboard 667MHz 1GB DDRII SDRAM
Chipset	Intel GM(E)965 & ICH8M (82801HBM)
Real Time Clock	Chipset integrated RTC with onboard lithium battery
Watchdog Timer	Generates a system reset with internal timer for 1min/s ~ 255min/s
Power Management	ACPI 1.0 compliant, supports power saving mode
PCI Enhanced IDE	One 44-pin UltraATA33 IDE interface supports up to 2 ATAPI devices
Serial ATA Interface	3 x serial ATAPI interface with 300MB/s transfer rate
VGA Interface	Intel integrated extreme GMA X3100 (Graphic Media Accelerator) Technology
Video Memory	Up to 384MB shared with system memory
DVI Interface	One onboard CH7307C DVI transmitter 26-pin DVI connector with optional Chronitel CH7307C DVI transmitter
LVDS interface	Onboard 18/24-bit Single/dual channel LVDS connector with +3.3V/+5V/+12V supply One optional Chronitel CH7308 LVDS transmitter for 18/24-bit Single/dual channel LVDS interface with + 3.3V/+5V/+12V supply
SDTV/HDTV Interface	Onboard 5x2-pin SDTV/HDTV interface
Audio Interface	Intel integrated ICH8M with Realtek ALC888 HD Audio
LAN Interface	Two Intel 82573L Gigabit LAN
Solid State Disk	IDE supports 44-pin DiskOnModule with +5V/+3.3V power supply, One Compact Flash Type II
GPIO interface	Onboard programmable 8-bit Digital I/O interface
Extended Interface	One PCI slot, Two Mini PCI socket to support Mini PCI Type IIIA
Internal I/O Port	1 x slim FDD port, 1 x GPIO port, 1 x Parallel Port, 8 x USB ports, 1 x IDE, 1 x LVDS, 1 x LCD inverter connector, 1 x DVI, 1 x HDTV, 1 x Front panel Audio connector, 1 x CDIN connector, 1 x RS232/422/485, 5 x COM Port, 1 x IrDA Port and 1 x SMBus Port
Temperature	Operating within 0~60 centigrade Storage within -20~85 centigrade
Power Requirement	Standard 20-Pin ATX power supply or 12V DC Input

Dimension	203mm x 146mm
-----------	---------------

1.3 <Mechanical Drawing>

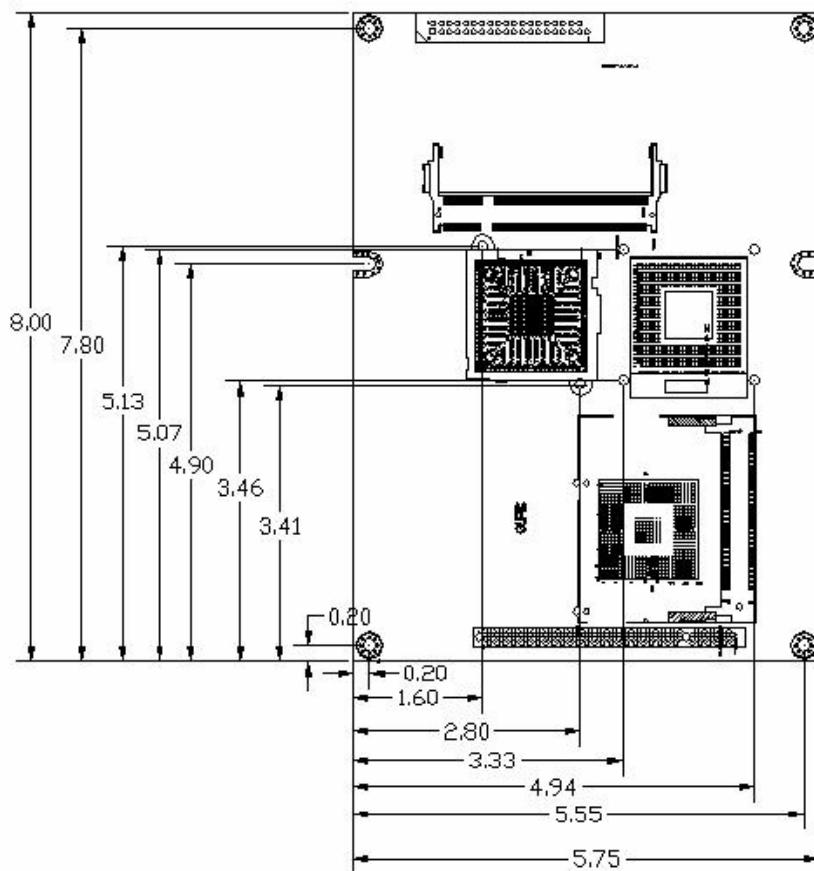

1.4 <Block Diagram>

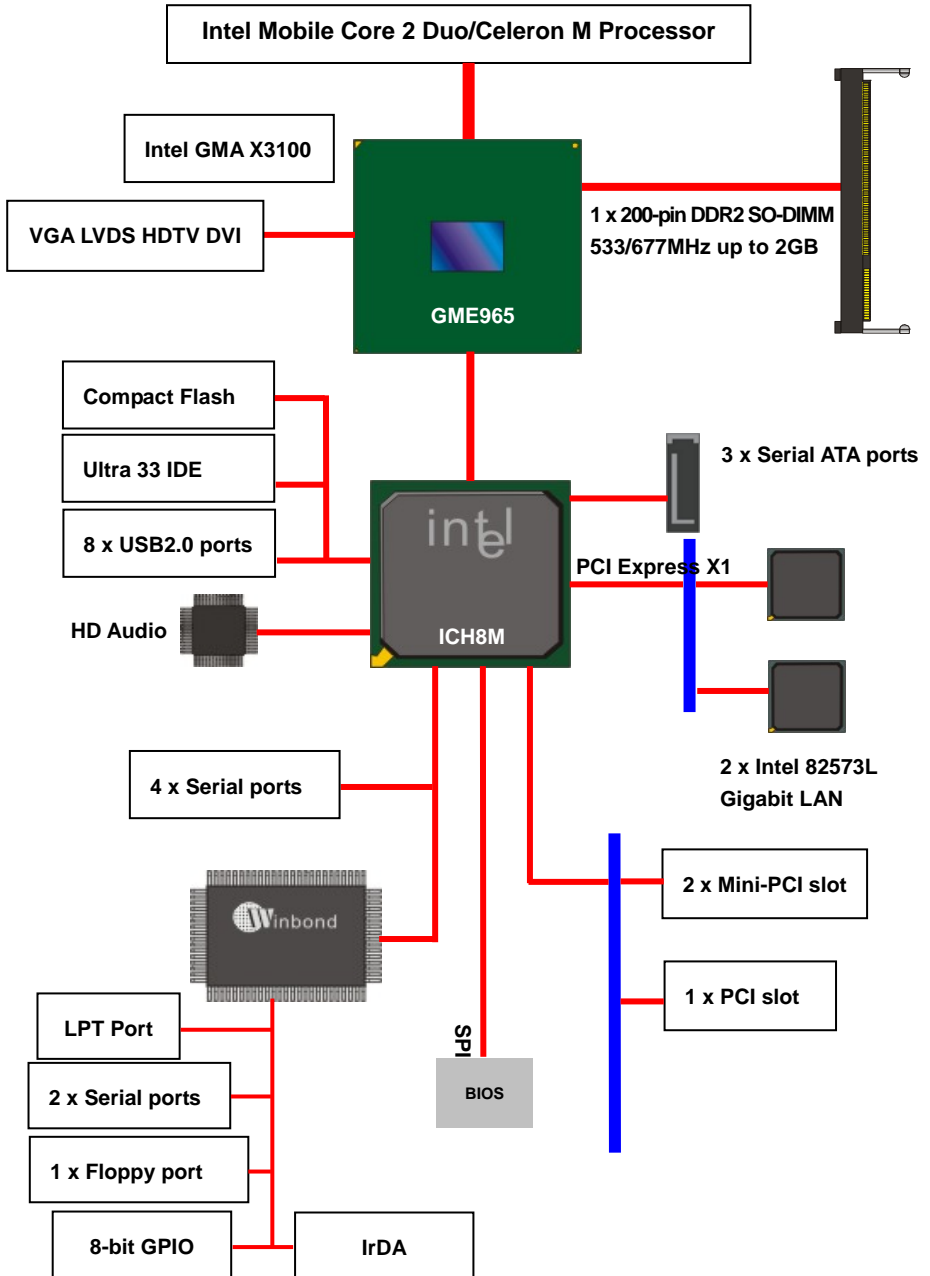

Chapter 2 <Hardware Setup>

2.1 <Connector Location>

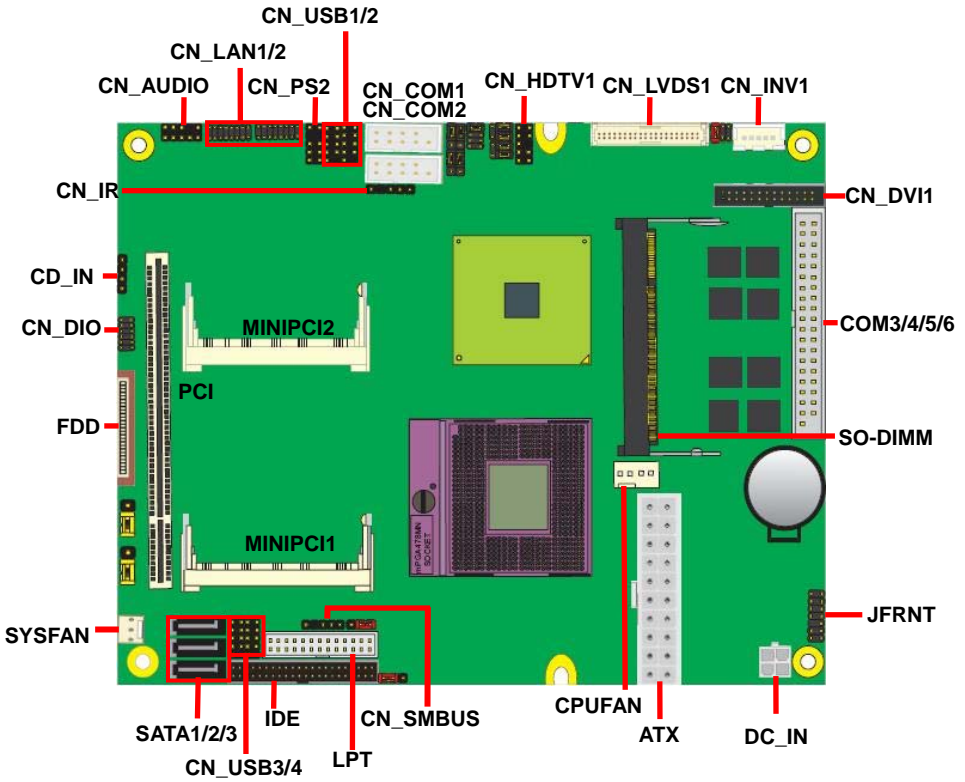

2.2 <Jumper Location & Reference>

Jumper	Function
JRTC	CMOS Operating/Clear Setting
JCFSEL	CF with IDE mode selection
JVLCD1	Panel Voltage Setting
JVSSD	DOM 3.3V / 5V Power selection
JAT	Power mode select
JP1	COM1 signal mode switch (For Pin-1 & Pin-9)
JP2	COM2 signal mode switch (For Pin-1 & Pin-9)
JCSEL1	CN_COM2 RS-232 RS422 RS485 Setting / CN_IR IrDA Setting
JCSEL2	

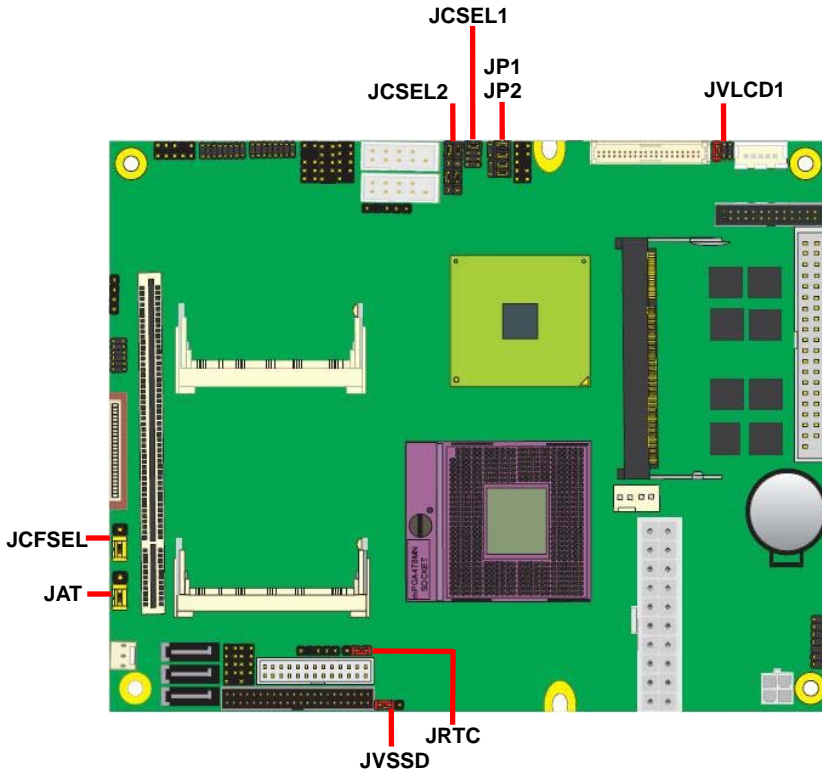

Jumper: **JAT**

Type: onboard 3-pin header

Power Mode	JAT
AT Mode	1-2
ATX Mode	2-3
Default setting: 2-3	
	

Jumper: **JP1 (COM 1)**

Type: onboard 3 x 2-pin header

Power Mode	JP1
Standard COM Port	3-5,4-6
Pin1 with 5V signal Pin9 with 12V signal	1-3,4-6 2-4,3-5
Default setting: 3-5, 4-6	
	

Jumper: **JP2 (COM 2)**

Type: onboard 3 x 2-pin header

Power Mode	JP2
Standard COM Port	3-5,4-6
Pin1 with 5V signal Pin9 with 12V signal	1-3,4-6 2-4,3-5
Default setting: 3-5, 4-6	
	

2.3 <Connector Reference>

2.3.1 <Internal Connectors>

Connector	Function	Remark
CPU	Socket 478 for socket-P CPU	
SO-DIMM	One 200-pin DDR2 SO-DIMM slot	
IDE	44-pin IDE connector	
FDD	26-pin slim type floppy connector	
LPT	26-pin LPT port connector	
SATA1/2/3	7-pin Serial ATA connector	
DC_IN	4-pin DC 12V input connector	DC input Mode
ATX	20-pin power input connector (ATX 20-pin power output)	ATX input Mode (DC output Mode)
CN_AUDIO	5 x 2-pin audio connector	
CN_PS2	PS/2 keyboard and mouse connector	
CD_IN	4-pin CD-ROM audio input connector	
CN_DIO	6 x 2-pin digital I/O connector	
CN_USB1/2/3/4	Four 5 x 2-pin USB connector	
CPUFAN	4-pin CPU cooler fan connector	
SYSFAN	3-pin system cooler fan connector	
CN_DVI1/2	13 x 2-pin DVI interface	
CN_HDTV1	5 x 2-pin HDTV interface	
CN_LVDS1/2	20 x 2-pin LVDS connector	
CN_INV1/2	5-pin LCD inverter connector	
CN_IR	5-pin IrDA connector	
JFRNT	14-pin front panel switch/indicator connector	
MiniPCI1/2	2 x Mini-PCI socket Type IIIA	
PCI	32-bit PCI slot	
CF	Compact Flash Type II socket	
COM1/2/3/4/5/6	Serial port connector	
JAT	Power mode select	

2.4 <CPU and Memory Setup>

2.4.1 <CPU Setup>

The board comes with the socket 478 for Intel Core 2 Duo/Celeron M **socket-P** processor only it supports new generation with 533/667/800MHz of front side bus.

Please follow the instruction to install the CPU properly.

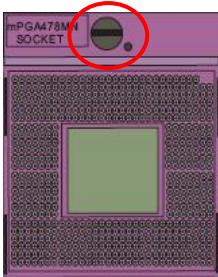

1. Use the flat-type screw drive to unlock the CPU socket



Unlock way

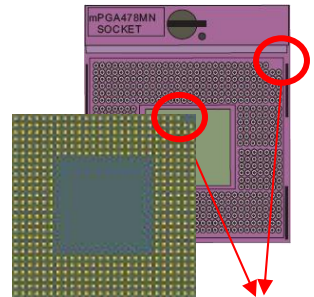

Check point

2. Follow the pin direction to install the processor on the socket

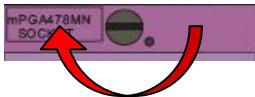

3. Lock the socket

4. Socket P has 478 pins, but is not pin-compatible with Socket M CPU.

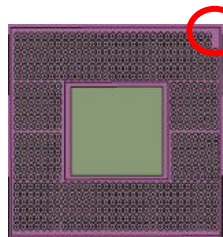

Socket-M CPU
Check point

2.4.2 <Memory Setup>

The board provides one 200-pin DDR2 SO-DIMM to support 533/667MHz memory module up to 2GB and optional 667MHz 1GB DDRII SDRAM of capacity. Non-ECC, unbuffered memory is supported only, dual channel technology is enabled automatically for higher performance.

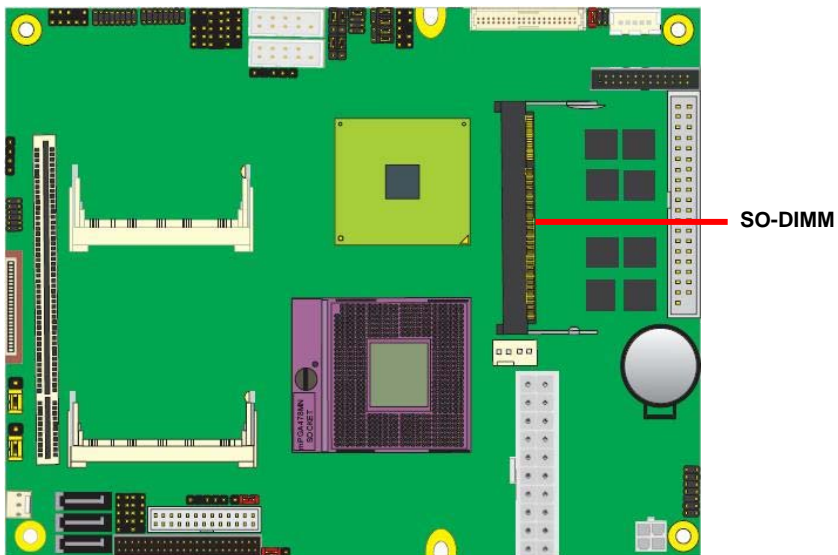

2.5 <CMOS Setup>

The board's data of CMOS can be setting in BIOS. If the board refuses to boot due to inappropriate CMOS settings, here is how to proceed to clear (reset) the CMOS to its default values.

Jumper: JRTC

Type: Onboard 3-pin jump

JRTC	Mode
1-2	Clear CMOS
2-3	Normal Operation

Default setting: 2-3

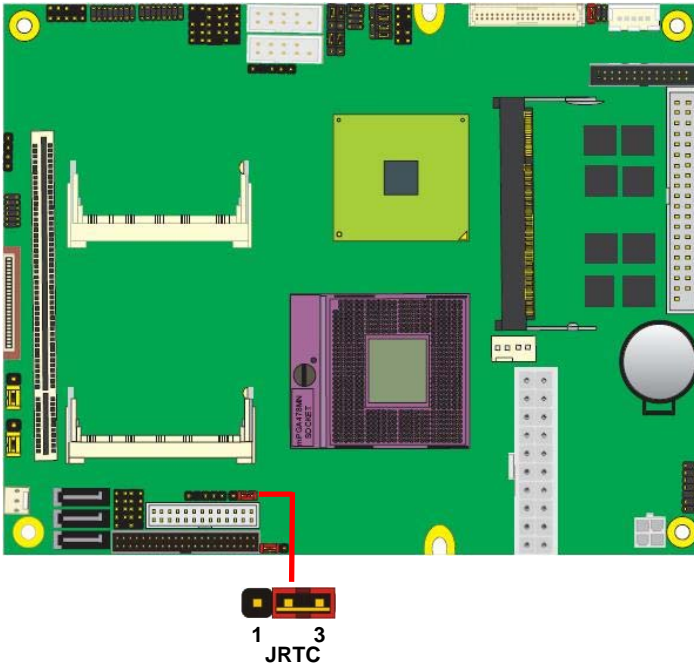

2.6 <Enhanced IDE Interface>

The board has one Ultra 33 IDE interface to support up to 2 ATAPI devices, or one ATAPI device and Compact Flash Type II socket on the solder side, with jumper **JCFSEL** for IDE master/slave mode selection. And provide **JVSSD** jumper to support +3.3V or +5V DOM selection.

Jumper: **JCFSEL**

Type: onboard 3-pin header

JCFSEL	Mode
1-2	Master
2-3	Slave

Default setting: 2-3

Jumper: **JVSSD**

Type: onboard 3-pin header

JVSSD	Mode
1-2	+5V
2-3	+3.3V

Default setting: 1-2

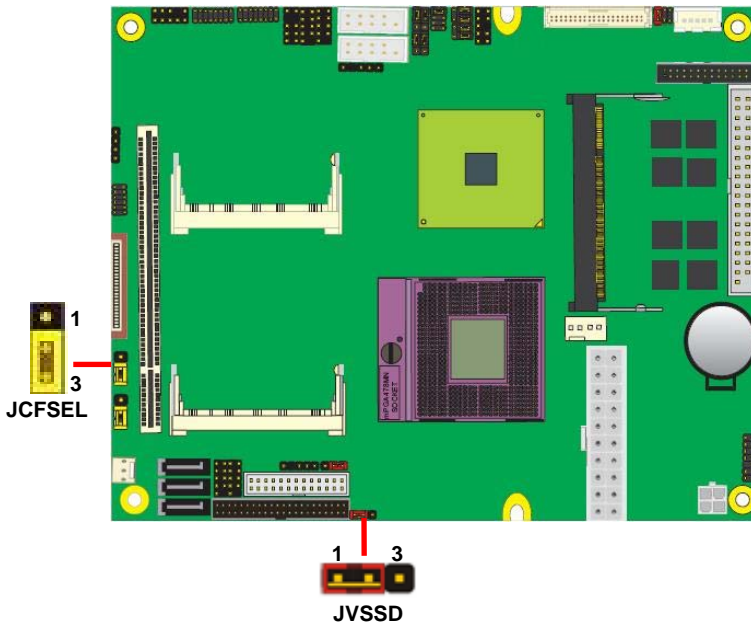

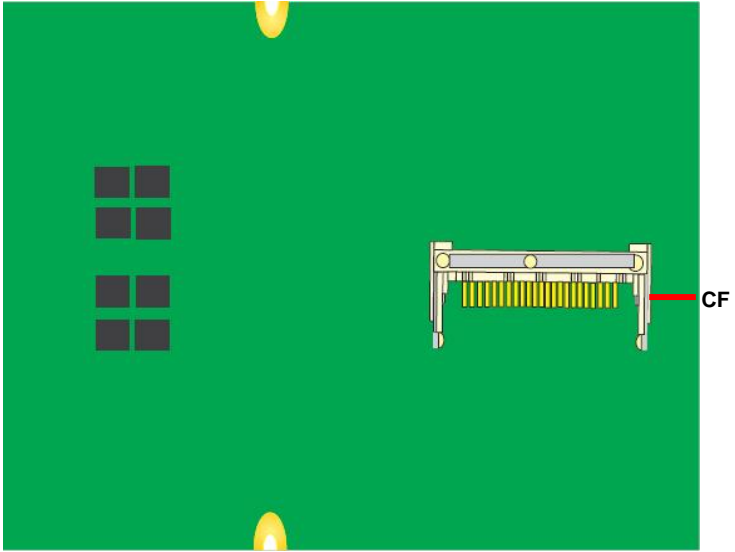

2.7 <Serial ATA Interface>

Based on Intel ICH8M, the board provides three Serial ATAII interfaces with up to 300MB/s of transfer rate.

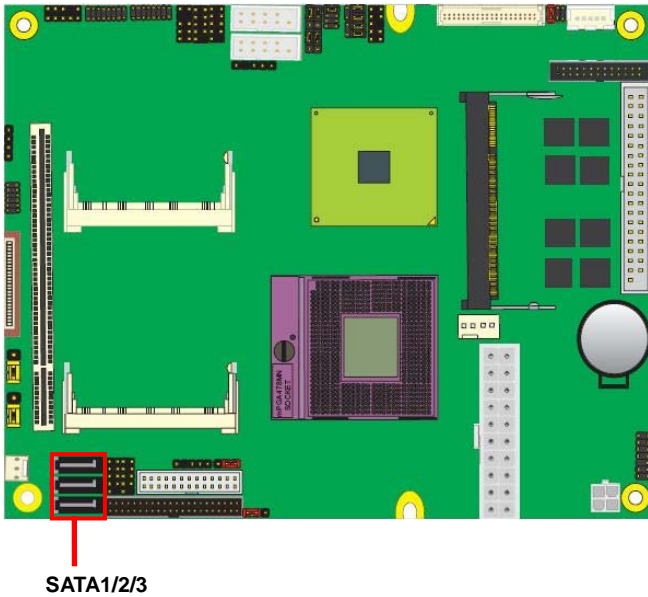

SATA1/2/3

2.8 <Floppy Port>

The board provides one slim type floppy port.

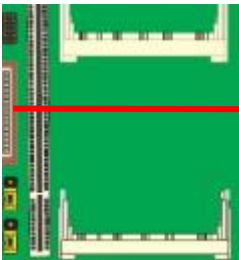
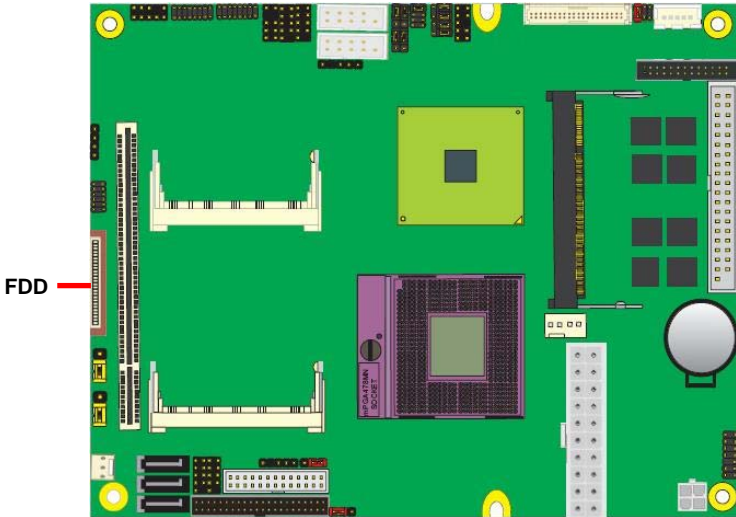

1. Lift up the brown plastic bar
2. Slot the cable in (Blue paste for brown bar side)
3. Press back the plastic bar

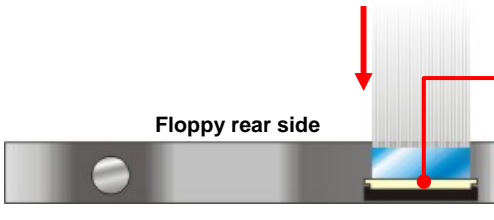

Floppy rear side

4. Lift up this plastic bar
5. Slot the cable in (Blue paste for outside)
6. Press back the plastic bar

2.9 <Ethernet Interface>

The board integrates with two Intel PCI Express Gigabit Ethernet controllers, as the PCI Express x1 can speed up to 250MB/s of transfer rate instead of late PCI bus with 133MB/s of transfer rate. The Intel Gigabit Ethernet supports triple speed of 10/100/1000Base-T and Wake-On-LAN supported.

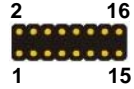

Connector: **CN_LAN1/2**

Type: onboard 16-pin connector for LAN connector (pitch = 2.0mm)

Pin	Description	Pin	Description
1	RTD0+	2	RTD1+
3	RTD0-	4	RTD1-
5	N/C	6	GND
7	RTD2+	8	RTD3+
9	RTD2-	10	RTD3-
11	GND	12	GND
13	RACTLED0-	14	RLINK1H0-
15	RLINK0	16	RLINK1G0-

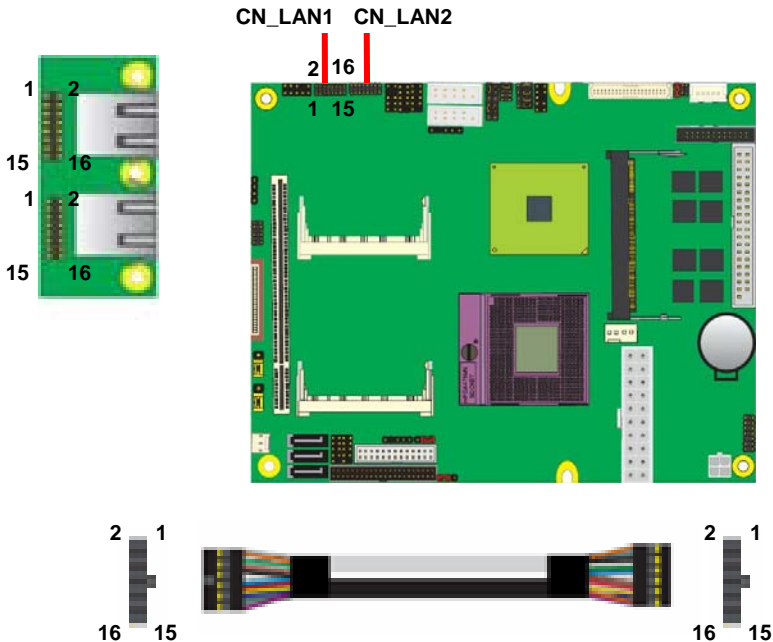

2.10 <Onboard Display Interface>

Based on Intel GM(E)965 chipset with built-in GMA (Graphic Media Accelerator) X3100 graphics, the board provides, 40-pin LVDS interface with 5-pin LCD backlight inverter connector. The board provides dual display function with clone mode and extended desktop mode for two VGA, two LVDS, one HDTV and two DVI.

Two VGA or two DVI type:

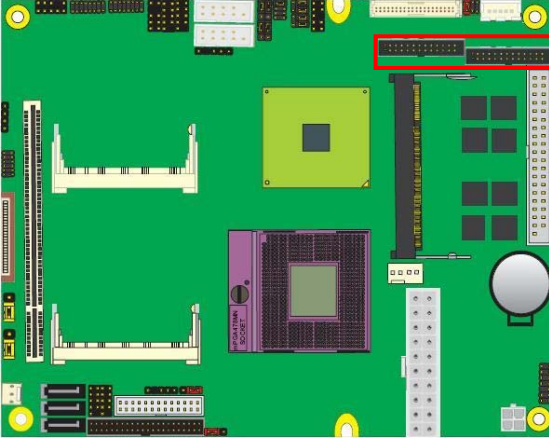

Two LVDS type:

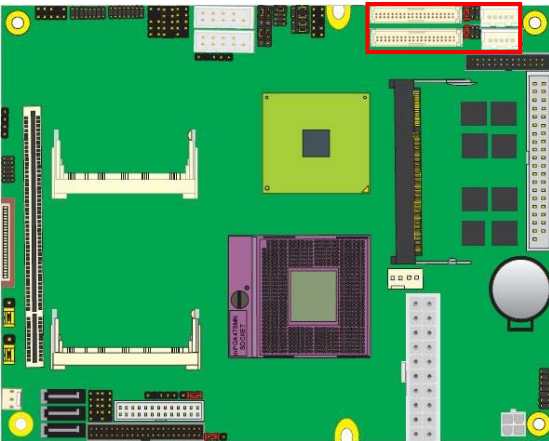

2.10.1 <Digital Display>

The board provides one 40-pin LVDS connector up to two mode for 18/24-bit single/dual channel panels, supports up to 1600 x 1200 (UXGA) resolution, with LCD backlight inverter connector and jumper for panel voltage setting.

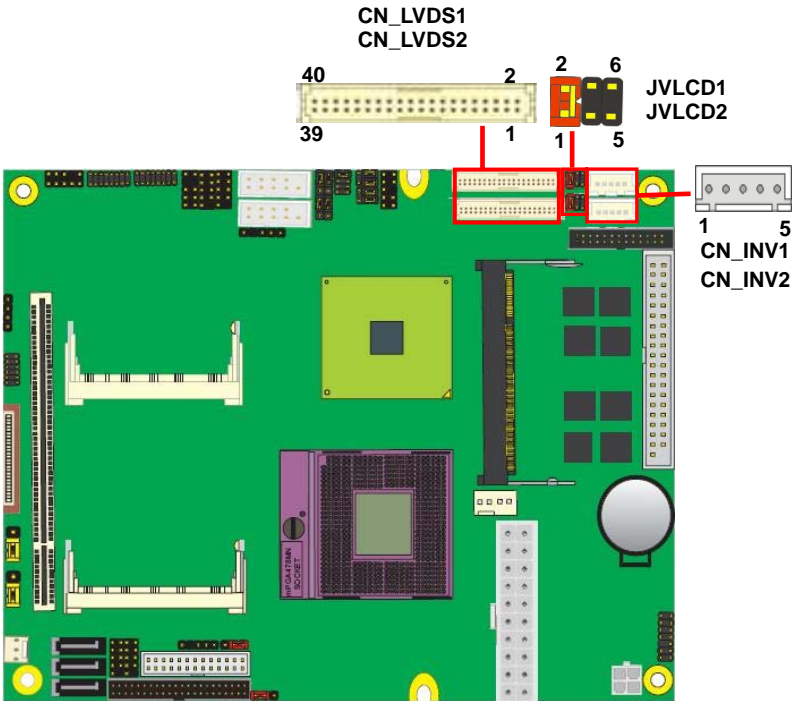

Effective patterns of connection: 1-2 / 3-4 / 5-6



Warning: others cause damages

Connector: **CN_INV1 CN_INV2**
 Type: 5-pin LVDS Power Header

Pin	Description
1	+12V
2	CTLBKL
3	GND
4	GND
5	ENABKL

Connector: **JVLCD1 JVLCD2**
 Type: 6-pin Power select Header

Pin	Description
1-2	LCDVCC (3.3V)
3-4	LCDVCC (5V)
5-6	LCDVCC (12V)

Default setting: 1-2

Connector: **CN_LVDS1 CN_LVDS2**
 Type: onboard 40-pin connector for LVDS connector
 Connector model: **HIROSE DF13-40DP-1.25V**

Pin	Signal	Pin	Signal
2	LCDVCC	1	LCDVCC
4	GND	3	GND
6	ATX0-	5	BTX0-
8	ATX0+	7	BTX0+
10	GND	9	GND
12	ATX1-	11	BTX1-
14	ATX1+	13	BTX1+
16	GND	15	GND
18	ATX2-	17	BTX2-
20	ATX2+	19	BTX2+
22	GND	21	GND
24	ACLK-	23	BTX3-
26	ACLK+	25	BTX3+
28	GND	27	GND
30	ATX3-	29	BCLK-
32	ATX3+	31	BCLK+
34	GND	33	GND
36	DDCPCLK	35	N/C
38	DDCPDATA	37	N/C
40	N/C	39	N/C

To setup the LCD, you need the component below:

1. A panel with LVDS interfaces.
2. An inverter for panel's backlight power.
3. A LCD cable and an inverter cable.

For the cables, please follow the pin assignment of the connector to make a cable, because every panel has its own pin assignment, so we do not provide a standard cable; please find a local cable manufacture to make cables.

LCD Installation Guide:

1. Preparing the 3307830, LCD panel and the backlight inverter.

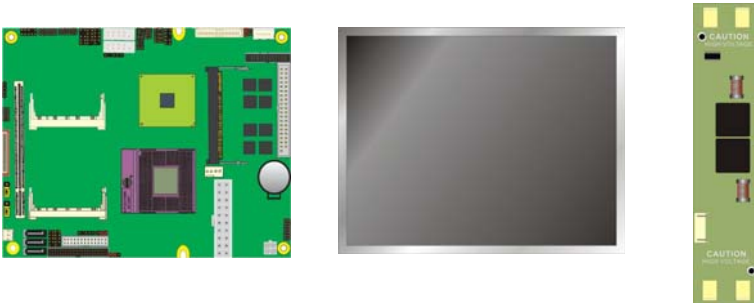

2. Please check the datasheet of the panel to see the voltage of the panel, and set the jumper **JVLCD1 JVLCD2** to +12V or +5V or +3.3V.
3. You would need a LVDS type cable.

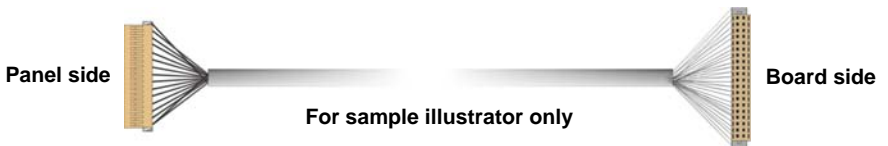

4. To connect all of the devices well.

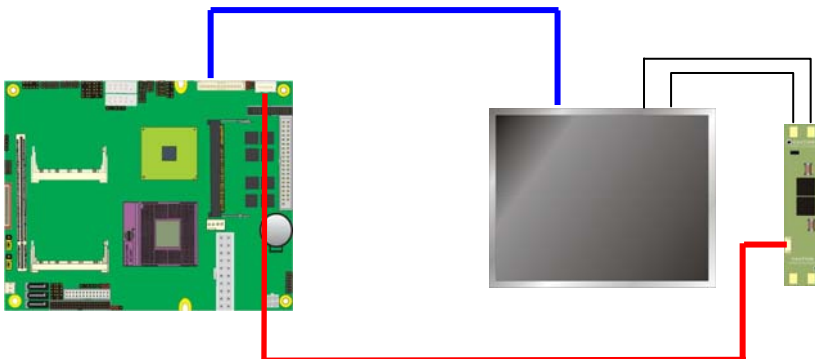

After setup the devices well, you need to select the LCD type in the BIOS.



The panel type mapping is list below:

BIOS panel type selection form (BIOS Version:1.0)			
18-bit Single channel		24-bit Dual channel	
NO.	Output format	NO.	Output format
1	800 x 480	10	1024 x 768
2	800 x 600	11	1280 x 768
3	1024 x 768	12	1280 x 1024
24-bit Single channel		13	1366 x 768
4	1024 x 768	14	1400 x 1050
5	1280 x 768	15	1600 x 1200
6	1280 x 800	16	1920 x 1080
7	1280 x 1024		
8	1366 x 768		
9	1600 x 1200		

2.10.2 <HDTV Interface>

The board provides an HDTV interface with Intel GM(E) 965, supports Composite, S-Video and Component with PAL and NTSC of TV system, and display (clone or extended desktop) function with VGA, LVDS, DVI.

Connector: **CN_HDTV1**



Connector type: 10-pin header HDTV connector (pitch = 2.54mm)

Pin Number	Assignment	Pin Number	Assignment
1	GND	2	DACB_L
3	DACC_L	4	GND
5	GND	6	N/C
7	DACA_L	8	GND
9	N/C	10	N/C

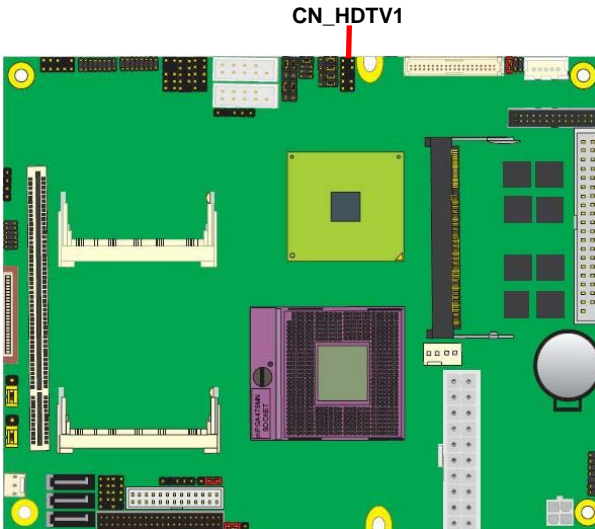

2.11 <Integrated Audio Interface>

The board integrates onboard audio interface with REALTEK ALC888 codec, with Intel next generation of audio standard as High Definition Audio, it offers more sound and other advantages than former HD audio compliance.

The main specifications of ALC888 are:

- **High-performance DACs with 97dB SNR (A-Weighting),**
- **Ten DAC channels support 16/20/24-bit PCM format for 2 sound playback, plus 2 channels of independent stereo sound output (multiple streaming) through the front panel output**
- **16/20/24-bit S/PDIF-OUT supports 44.1k/48k/96k/192kHz sample rate**
- **High-quality analog differential CD input**
- **Meets performance requirements for Microsoft WLP 3.0 Premium desktop and mobile PCs**

The board provides 2 channels audio speaker out and Mic-In ports for front I/O panel through cable.

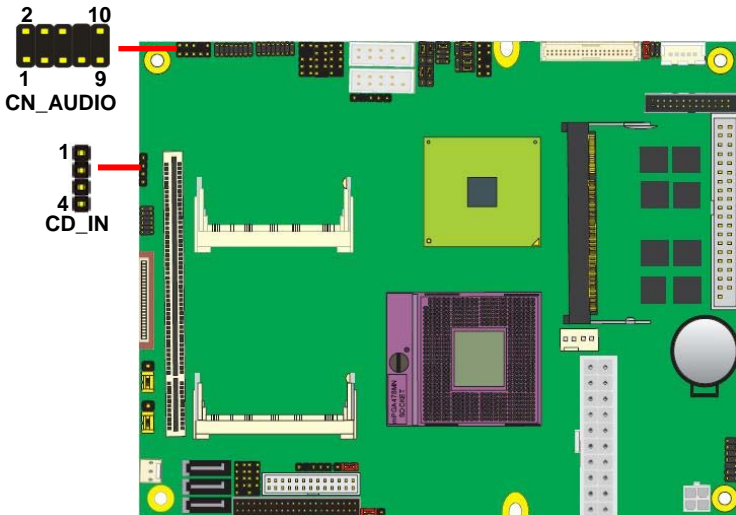

Connector: CN_AUDIO

Type: 10-pin (2 x 5) 2.54mm-pitch header

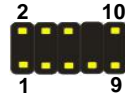

Pin	Description	Pin	Description
1	MIC2_L	2	Ground
3	MIC2_R	4	VCC
5	FP_OUT_R	6	MIC2_JD
7	SENSE_B	8	N/C
9	FP_OUT_L	10	LINE2_JD

Connector: CD_IN

Type: 4-pin header (pitch = 2.54mm)



Pin	Description
1	CD – Left
2	Ground
3	Ground
4	CD – Right

2.12 <GPIO Interface>

The board provides a programmable 8-bit digital I/O interface; you can use this general purpose I/O port for system control like POS or KIOSK.

Connector: **CN_DIO**

Type: 12-pin (6 x 2) 2.0mm-pitch header

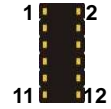

Pin	Description	Pin	Description
1	Ground	2	Ground
3	GP10	4	GP14
5	GP11	6	GP15
7	GP12	8	GP16
9	GP13	10	GP17
11	VCC	12	+12V

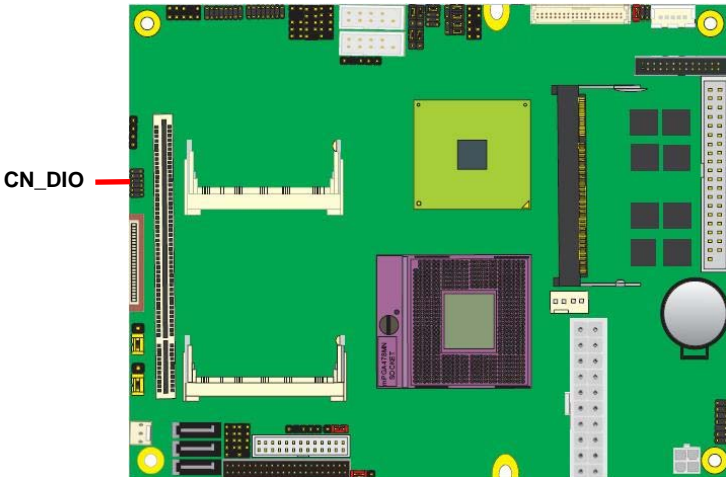

2.13 <Power Supply>

2.13.1.1 <DC_IN Input>

The board requires 4-pin DC 12V input or onboard 20-pin ATX2.0, for the input current, please take a reference of the power consumption report on appendix.

Connector: **DC_IN**

Type: 4-pin DC power connector

Pin	Description	Pin	Description
1	Ground	2	Ground
3	+12V	4	+12V

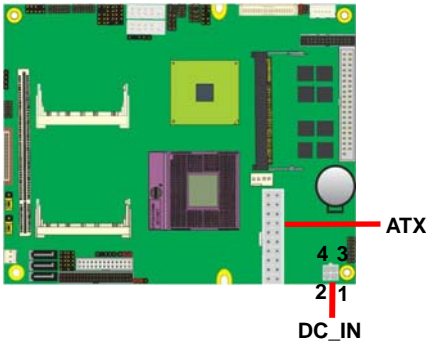

ATX power output cable to powering device.

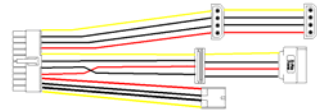

▪ DC Input Mode

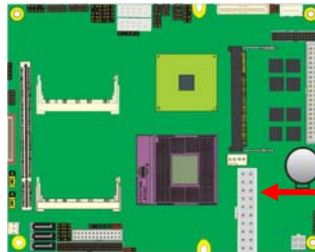

2.13.1.2 <ATX Output>

The board provides one 20-pin ATX connector for +5V/+12V output for powering your HDD, CDROM or other devices when DC-input mode has been used.

Attention: When DC-IN had power supplied, the ATX become output !

Avoid DC-IN and ATX power supply input at the same time !

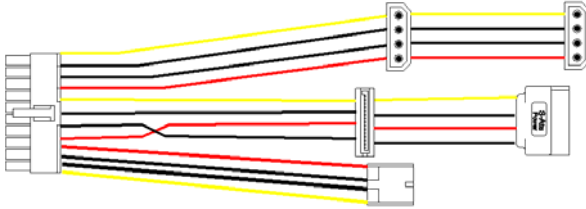

Connector: **ATX Output** (When DC-IN be used)

Type: 20-pin ATX connector for +5V/+12V

PIN	Assignment	PIN	Assignment
1	*	13	*
2	*	14	*
3	*	15	*
4	5V	16	*
5	GND	17	*
6	*	18	GND
7	GND	19	GND
8	*	20	*
9	*	21	*
10	12V	22	5V

Note: Maximum output voltage: 12V/2A & 5V/3A

2.13.2 <ATX Power Mode>

Connector: **ATX** (It also can become Output when DC-IN be used)

Type: 20-pin ATX power connector

PIN	Assignment	PIN	Assignment
1	3.3V	11	3.3V
2	3.3V	12	-12V
3	GND	13	GND
4	5V	14	PS_ON
5	GND	15	GND
6	5V	16	GND
7	GND	17	GND
8	PW_OK	18	-5V
9	5V_SB	19	5V
10	12V	20	5V

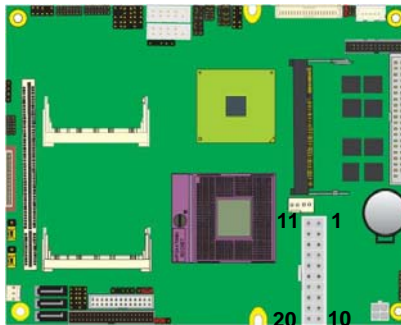

ATX Power



2.14 <Switch and Indicator>

The **JFRNT** provides front control panel of the board, such as power button, reset and beeper, etc. Please check well before you connecting the cables on the chassis.

Connector: **JFRNT**

Type: onboard 14-pin (2 x 7) 2.54-pitch header

Function	Signal	PIN		Signal	Function
IDE LED	HDLED+	1	2	PWRLED+	Power LED
	HDLED-	3	4	N/C	
Reset	Reset+	5	6	PWRLED-	Speaker
	Reset-	7	8	SPK+	
N/C		9	10	N/C	
Power Button	PWRBT-	11	12	N/C	
	PWRBT+	13	14	SPK-	

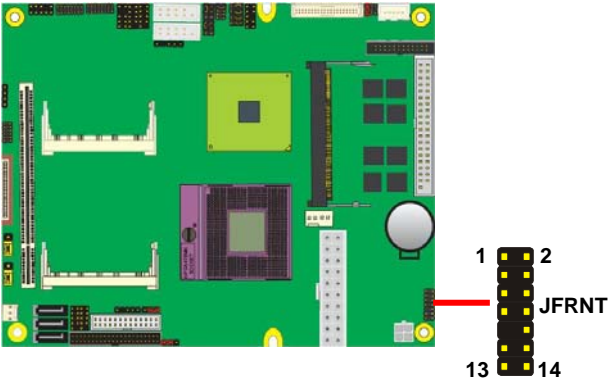

3.2 <Video Memory Setup>

Based on Intel® GM(E)965 chipset with GMA (Graphic Media Accelerator) X3100, the board supports Intel® DVMT (Dynamic Video Memory Technology) 4.0, which would allow the video memory to be allocated up to 384MB.

To support DVMT, you need to install the Intel GMA X3100 Driver with supported OS.



BIOS Setup:

On-Chip Frame Buffer Size:

This item can let you select video memory which been allocated for legacy VGA and SVGA graphics support and compatibility. The available option is **1MB** and **8MB**.

DVMT / Fixed Memory Size:

This item can let you select a static amount of page-locked graphics memory which will be allocated during driver initialization. Once you select the memory amount, it will be no longer available for system memory.

3.3 <Display Properties Setting>

Based on Intel GM(E)965 GMCH with GMA X3100 (Graphic Media Accelerator), the board supports two DACs for display device as different resolution and color bit. Please install the Intel Graphic Driver before you starting setup display devices.

1. Click right button on the desktop to lunch **display properties**

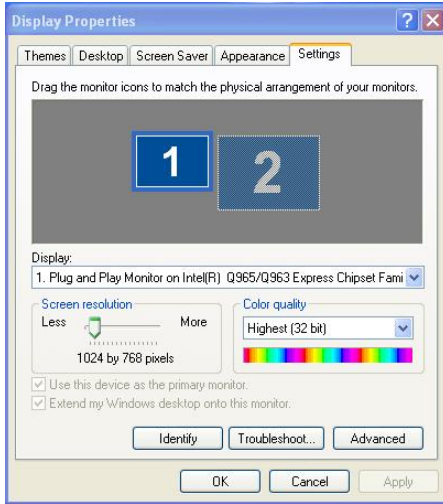

2. Click **Advanced** button for more specificity setup.

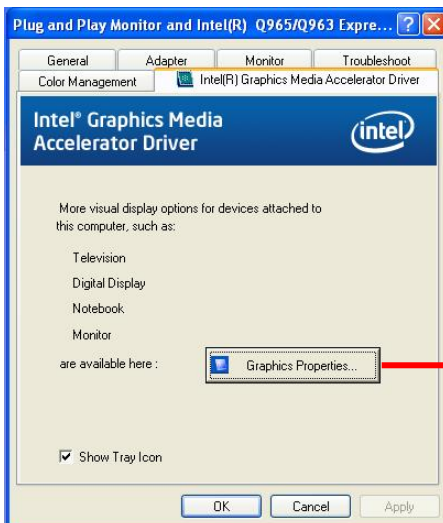

Click **Graphics Properties...** for advanced setup

3. This setup options can let you define each device settings.

Click **Monitor** to setup the CRT monitor for Colors, Resolution and Refresh Rate

Click **Intel(R) Dual Display Clone** to setup the dual display mode as same screen

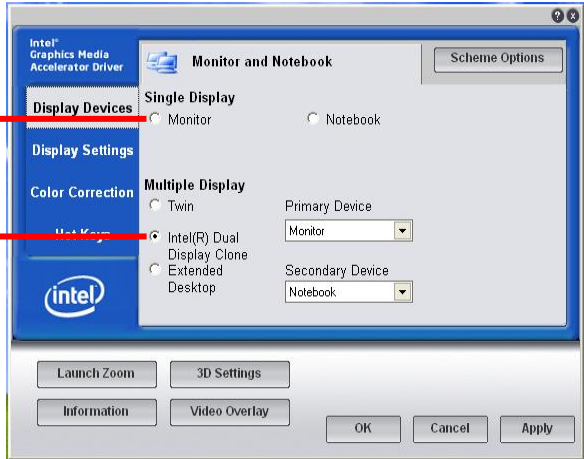

(This page is left for blank)



Appendix A <I/O Port Pin Assignment>

A.1 <IDE Port>

Connector: IDE

Type: 44-pin (22 x 2) box header



Pin	Description	Pin	Description
1	Reset	2	Ground
3	D7	4	D8
5	D6	6	D9
7	D5	8	D10
9	D4	10	D11
11	D3	12	D12
13	D2	14	D13
15	D1	16	D14
17	D0	18	D15
19	Ground	20	N/C
21	REQ	22	Ground
23	-IOW	24	Ground
25	-IOR	26	Ground
27	IORDY	28	Ground
29	DACK	30	Ground
31	IDEIRQ	32	N/C
33	A1	34	66DET
35	A0	36	A2
37	-CS1	38	-CS3
39	-HD LED1	40	Ground
41	By JVSSD Jumper	42	By JVSSD Jumper
43	Ground	44	Ground

A.2 <Serial ATA Port>

Connector: **SATA1/2/3**

Type: 7-pin wafer connector

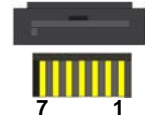

1	2	3	4	5	6	7
GND	SATA_TXP0	SATA_TXN0	GND	SATA_RXN0	SATA_RXP0	GND

A.3 <Floppy Port>

Connector: **FDD**

Type: 26-pin connector



Pin	Description	Pin	Description
1	VCC	2	INDEX
3	VCC	4	DR0
5	VCC	6	DSKCHG
7	N/C	8	N/C
9	N/C	10	MTR0
11	DRVDE0	12	DIR
13	N/C	14	STEP
15	Ground	16	WRITE DATA
17	Ground	18	WRITE GATE
19	Ground	20	TRAK 0
21	N/C	22	WRPT0
23	Ground	24	RDATA-
25	Ground	26	HDSEL

A.4 <IrDA Port>

Connector: **CN_IR**

Type: 5-pin header for SIR Ports

Pin	Description
1	VCC
2	N/C
3	IRRX
4	Ground
5	IRTX



JCSEL1 must jump to "IrDA"

A.5 <SMBUS Port>

Connector: **CN_SMBUS**

Type: 5-pin header for SMBUS Ports

Pin	Description
1	V5S
2	N/C
3	SMBDATA
4	SMBCLK
5	Ground



A.6 <Serial Port 1>

Connector: **CN_COM1**

Type: 9-pin box header

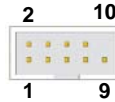

Pin	Description	Pin	Description
1	DCD /+5V	2	RX
3	TX	4	DTR
5	Ground	6	DSR
7	RTS	8	CTS
9	RI /+12V		

A.7 <Serial Port 2>

Connector: **CN_COM2**

Type: 9-pin box header

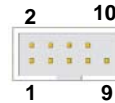

Pin	Description	Pin	Description
1	DCD/422TX-/485-/ +5V	2	RX/422TX+/485+
3	TX/422RX+	4	DTR/422RX-
5	Ground	6	DSR
7	RTS	8	CTS
9	RI /+12V		

Setting RS-232, RS-422, RS-485 & IrDA:

Function	JCSEL1	JCSEL2
IrDA		
RS-422		
RS-485		
RS-232		

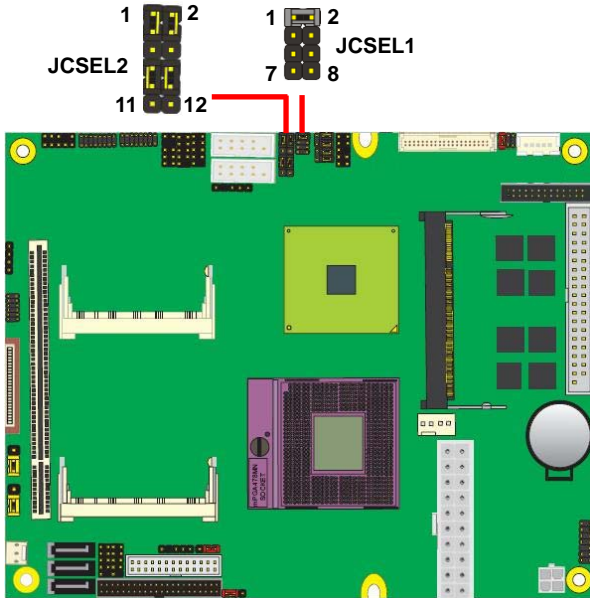

A.8 <Parallel Port>

Connector: **LPT**

Type: 26-Pin box header

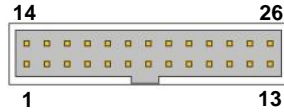

Pin	Description	Pin	Description
1	-PSTB	14	AFD-
2	PRO0	15	ERR-
3	PRO1	16	INT-
4	PRO2	17	SLIN-
5	PRO3	18	Ground
6	PRO4	19	Ground
7	PRO5	20	Ground
8	PRO6	21	Ground
9	PRO7	22	Ground
10	ACK-	23	Ground
11	BUSY	24	Ground
12	PE	25	Ground
13	SLCT	26	N/C

A.9 <LAN Port>

Connector: **RJ45_1/2**

Type: RJ45 connector with LED

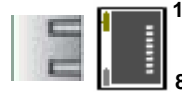

Pin	1	2	3	4	5	6	7	8
Description	MI0+	MI0-	MI1+	MI2+	MI2-	MI1-	MI3+	MI3-

Connector: **CN_LAN1/2**

Type: 16-pin (8 x 2) header for LAN Ports

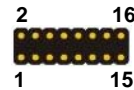

Pin	Description	Pin	Description
1	RTD1+	2	RTD2-
3	RTD1-	4	RTD2+
5	N/C	6	Ground
7	RTD3+	8	RTD4+
9	RTD3-	10	RTD4-
11	Ground	12	Ground
13	RLINK1	14	RLINK1H1-
15	RACTLED1	16	RLINK1G1-

A.10 <USB Interface>

Connector: **CN_USB1/2/3/4**

Type: 10-pin (5 x 2) header for dual USB Ports



Pin	Description	Pin	Description
1	VCC	2	VCC
3	Data0-	4	Data1-
5	Data0+	6	Data1+
7	Ground	8	Ground
9	Ground	10	N/C

A.11 <COM3/4/5/6 Port>

Connector: **COM3/4/5/6**

Type: 40-Pin box header



Pin	Description	Pin	Description
1	HS_DCD1	2	HS_RXD1
3	HS_TXD1	4	HS_DTR1
5	Ground	6	HS_DSR1
7	HS_RTS1	8	HS_CTS1
9	HS_RI1	10	N/C
11	HS_DCD2	12	HS_RXD2
13	HS_TXD2	14	HS_DTR2
15	Ground	16	HS_DSR2
17	HS_RTS2	18	HS_CTS2
19	HS_RI2	20	N/C
21	HS_DCD3	22	HS_RXD3
23	HS_TXD3	24	HS_DTR3
25	Ground	26	HS_DSR3
27	HS_RTS3	28	HS_CTS3
29	HS_RI3	30	N/C
31	HS_DCD4	32	HS_RXD4
33	HS_TXD4	34	HS_DTR4
35	Ground	36	HS_DSR4
37	HS_RTS4	38	HS_CTS4
39	HS_RI4	40	N/C

A.12 <DVI Port>

Connector: **CN_DVI1/2**

Type: onboard 26-pin connector for DVI connector





Pin	Assignment	Pin	Assignment
1	TDC1+	2	TDC1-
3	GND	4	GND
5	TLC+	6	TLC-
7	GND	8	V5S
9	N/C	10	N/C
11	TDC2+	12	TDC2-
13	GND	14	GND
15	TDC0+	16	TDC0-
17	N/C	18	HPD
19	DVI_DA	20	DVI_SL
21	GND	22	BR
23	BG	24	BB
25	5HSYNC	26	5VSYNC



Appendix B <System Resources>

B1. <Direct Memory Access (DMA)>

-  2 Standard floppy disk controller
-  4 Direct memory access controller

B2. <Input /Output (IO)>

	[00000000 - 0000000F]	Direct memory access controller
	[00000000 - 00000CF7]	PCI bus
	[00000010 - 0000001F]	Motherboard resources
	[00000020 - 00000021]	Programmable interrupt controller
	[00000022 - 0000003F]	Motherboard resources
	[00000040 - 00000043]	System timer
	[00000044 - 0000005F]	Motherboard resources
	[00000060 - 00000060]	Standard 101/102-Key or Microsoft Natural PS/2 Keyboard
	[00000061 - 00000061]	System speaker
	[00000062 - 00000063]	Motherboard resources
	[00000064 - 00000064]	Standard 101/102-Key or Microsoft Natural PS/2 Keyboard
	[00000065 - 0000006F]	Motherboard resources
	[00000070 - 00000073]	System CMOS/real time clock
	[00000074 - 0000007F]	Motherboard resources
	[00000080 - 00000090]	Direct memory access controller
	[00000091 - 00000093]	Motherboard resources
	[00000094 - 0000009F]	Direct memory access controller
	[000000A0 - 000000A1]	Programmable interrupt controller
	[000000A2 - 000000BF]	Motherboard resources
	[000000C0 - 000000DF]	Direct memory access controller
	[000000E0 - 000000EF]	Motherboard resources
	[000000F0 - 000000FF]	Numeric data processor
	[00000170 - 00000177]	Secondary IDE Channel
	[000001F0 - 000001F7]	Primary IDE Channel
	[00000274 - 00000277]	ISAPNP Read Data Port
	[00000279 - 00000279]	ISAPNP Read Data Port
	[000002E8 - 000002EF]	Communications Port (COM3)
	[000002F8 - 000002FF]	Communications Port (COM2)
	[00000376 - 00000376]	Secondary IDE Channel
	[00000378 - 0000037F]	Printer Port (LPT1)
	[000003B0 - 000003BB]	Mobile Intel(R) 965 Express Chipset Family
	[000003C0 - 000003DF]	Mobile Intel(R) 965 Express Chipset Family
	[000003E8 - 000003EF]	Communications Port (COM4)
	[000003F0 - 000003F5]	Standard floppy disk controller
	[000003F6 - 000003F6]	Primary IDE Channel
	[000003F7 - 000003F7]	Standard floppy disk controller
	[000003F8 - 000003FF]	Communications Port (COM1)
	[00000400 - 000004BF]	Motherboard resources
	[000004D0 - 000004D1]	Motherboard resources
	[000004E8 - 000004EF]	Communications Port (COM5)
	[000004F8 - 000004FF]	Communications Port (COM6)
	[00000500 - 0000051F]	Intel(R) ICH8 Family SMBus Controller - 283E

	[00000778 - 0000077B] Printer Port (LPT1)
	[00000880 - 0000088F] Motherboard resources
	[00000A79 - 00000A79] ISAPNP Read Data Port
	[00000D00 - 0000FFFF] PCI bus
	[0000C000 - 0000CFFF] Intel(R) ICH8 Family PCI Express Root Port 2 - 2841
	[0000CF00 - 0000CF1F] Intel(R) PRO/1000 PL Network Connection
	[0000D000 - 0000DFFF] Intel(R) ICH8 Family PCI Express Root Port 1 - 283F
	[0000DF00 - 0000DF1F] Intel(R) PRO/1000 PL Network Connection #2
	[0000E000 - 0000EFFF] PCI standard PCI-to-PCI bridge
	[0000F300 - 0000F30F] Intel(R) ICH8M 3 port Serial ATA Storage Controller - 2828
	[0000F400 - 0000F40F] Intel(R) ICH8M 3 port Serial ATA Storage Controller - 2828
	[0000F500 - 0000F503] Intel(R) ICH8M 3 port Serial ATA Storage Controller - 2828
	[0000F600 - 0000F607] Intel(R) ICH8M 3 port Serial ATA Storage Controller - 2828
	[0000F700 - 0000F703] Intel(R) ICH8M 3 port Serial ATA Storage Controller - 2828
	[0000F800 - 0000F807] Intel(R) ICH8M 3 port Serial ATA Storage Controller - 2828
	[0000F900 - 0000F90F] Intel(R) ICH8M Ultra ATA Storage Controllers - 2850
	[0000FA00 - 0000FA1F] Intel(R) ICH8 Family USB Universal Host Controller - 2832
	[0000FB00 - 0000FB1F] Intel(R) ICH8 Family USB Universal Host Controller - 2831
	[0000FC00 - 0000FC1F] Intel(R) ICH8 Family USB Universal Host Controller - 2830
	[0000FD00 - 0000FD1F] Intel(R) ICH8 Family USB Universal Host Controller - 2835
	[0000FE00 - 0000FE1F] Intel(R) ICH8 Family USB Universal Host Controller - 2834
	[0000FF00 - 0000FF07] Mobile Intel(R) 965 Express Chipset Family

B3. <Memory Address Map>



Copyrights

This document is copyrighted and all rights are reserved. It does not allow any non authorization in copied, photocopied, translated or reproduced to any electronic or machine readable form in whole or in part without prior written consent from the manufacturer.

In general, the manufacturer will not be liable for any direct, indirect, special, incidental or consequential damages arising from the use of inability to use the product or documentation, even if advised of the possibility of such damages. The manufacturer keeps the rights in the subject to change the contents of this document without prior notices in order to improve the function design, performance, quality and reliability. The author assumes no responsibility for any errors or omissions, which may appear in this document, nor does it make a commitment to update the information contained herein.

Trademarks

Intel is a registered trademark of Intel Corporation.

Award is a registered trademark of Award Software, Inc.

All other trademarks, products and or product's name mentioned herein are mentioned for identification purposes only, and may be trademarks and/or registered trademarks of their respective companies or owners.

Appendix C <Programming GPIO's>

The GPIO's can be programmed with the MSDOS debug program using simple IN/ OUT commands. The following lines show an example how to do this.

```
GPIO0.....GPIO7  bit0.....bit7
-o 2E 87
-o 2E 87                ;Enter configuration
-o 2E 07
-o 2F 09                ;Enable GPIO's function
-o 2E 30
-o 2F 02                ;Enable GPIO's configuration
-o 2E F0
-o 2F xx                ;Set GPIO's as input/output; set '1' for
                        input,'0' for output
-o 2E F1
-o 2F xx                ;If set GPIO's as output, in this register its
                        value can be set

Optional:
-o 2E F2
-o 2F xx                ; Data inversion register; '1' inverts the current
                        value of the bits,'0' leaves them as they are
-o 2E 30
-o 2F 01                ; Active GPIO's
```

For further information, please refer to Winbond W83627DHG datasheet.

Appendix D <Programming Watchdog Timer>

The watchdog timer makes the system auto-reset while it stops to work for a period.

The integrated watchdog timer can be setup as system reset mode by program.

Time-out Value Range

- 1 to 255
- Second or Minute

Program Sample

Watchdog timer setup as system reset with 5 second of timeout

```
2E, 87
2E, 87
2E, 07
2F, 08      Logical Device 8
2E, 30
2F, 01      Activate
2E, F5
2F, 00      Set as Second*
2E, F6
2F, 05      Set as 5
```

* Minute: bit 3 = 1; Second: bit 3 = 0

You can select Timer setting in the BIOS, after setting the time options, the system will reset according to the period of your selection.



Any advice or comments about our products and service, or anything we can help you with please don't hesitate to contact with us. We will do our best to support your products, projects and business.



Address: Global American, Inc.
17 Hampshire Drive
Hudson, NH 03051

Telephone: Toll Free U.S. Only (800) 833-8999
(603) 886-3900

FAX: (603) 886-4545

Website: <http://www.globalamericaninc.com>

Support: Technical Support at Global American
