



integration with integrity

User's Manual

Single Board Computer 3308200

Version 1.0 , March **2009**



Copyrights

This manual is copyrighted and all rights are reserved. It does not allow any non authorization in copied, photocopied, translated or reproduced to any electronic or machine readable form in whole or in part without prior written consent from the manufacturer.

In general, the manufacturer will not be liable for any direct, indirect, special, incidental or consequential damages arising from the use of inability to use the product or documentation, even if advised of the possibility of such damages. The manufacturer keeps the rights in the subject to change the contents of this manual without prior notices in order to improve the function design, performance, quality and reliability. The author assumes no responsibility for any errors or omissions, which may appear in this manual, nor does it make a commitment to update the information contained herein.

Trademarks

Intel is a registered trademark of Intel Corporation.

Award is a registered trademark of Award Software, Inc.

All other trademarks, products and or product's name mentioned herein are mentioned for identification purposes only, and may be trademarks and/or registered trademarks of their respective companies or owners.

Chapter 1

Introduction

1.7 Packing List



1 x 3308200 3.5" Embedded Board



1 x Driver CD



1 x Quick Installation Guide

If any of the above items is damaged or missing, contact your vendor immediately.

1.9 Specification

Form Factor	3.5" Embedded MiniBoard
CPU	Onboard Intel® Celeron M 1.0GHz zero cache processor, FAB400MHz.
Chipset	Intel® 852GM + Intel® ICH4
System Memory	1 x 200-pin SO-DIMM socket for DDR Up to 1GB SDRAM
VGA Controller	Intel® 852GM Extreme Graphics2 Engine up to 64MB UMA Video RAM CRT, 18/36-bit LVDS, Dual mode independent display
Ethernet	1 x Intel® 82562 10/100 Base-T Fast Ethernet LAN
I/O Chips	Winbond W83627HG
BIOS	Phoenix-Award PnP Flash BIOS
Audio	ALC655 AC'97 Codec, MIC-in/Line-in/Line-out
IDE Interface	1 x Ultra DMA 33, support 2 IDE devices
Serial Port	2 x COM port (RS-232)
Parallel Port/ Floppy	1 x SPP/EPP/ECP mode 1 x Floppy connector share with LPT port
IrDA	1 x IrDA connector
KBMS	Standard PS/2 Keyboard and Mouse
Universal Serial Bus	6 x USB 2.0 compliant
DIO	8-bit programmable Digital I/O
Expansion Interface	1 x Mini PCI slot 1 x CF II Socket
Hardware Monitor Chip	Integrated in W83627HG
RTC	Real Time Clock
Operation Temp.	-20°C ~ +70°C (-4°F ~ 158°F)
Watchdog Timer	255-level Reset
Dimension (L x W)	146 x 102 mm (5.7 " x 4.0 ")

1.10 Board Dimensions

Layout Top View

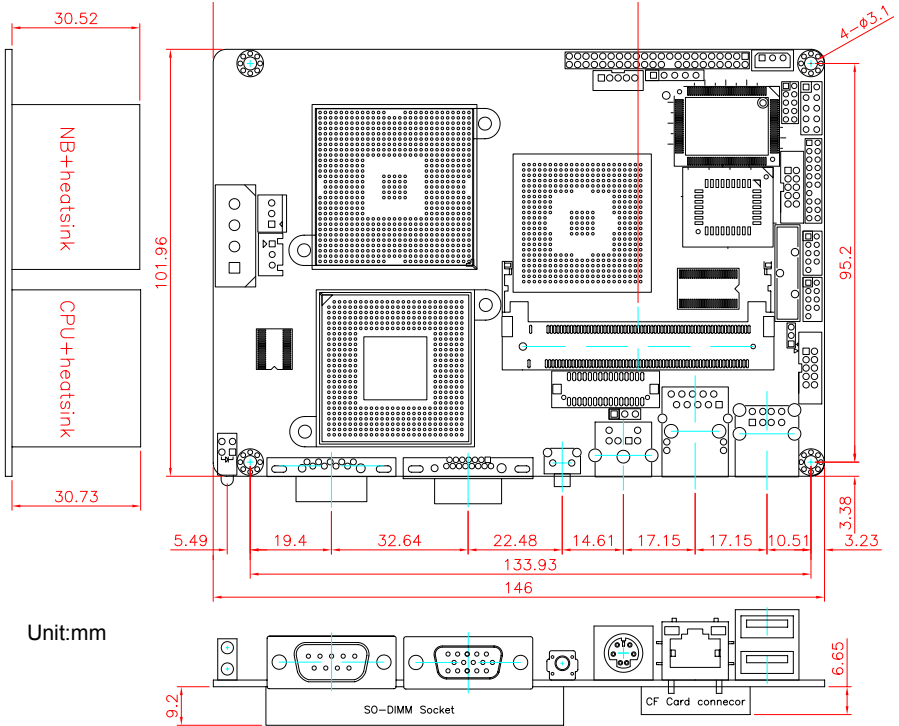

Layout Bottom View

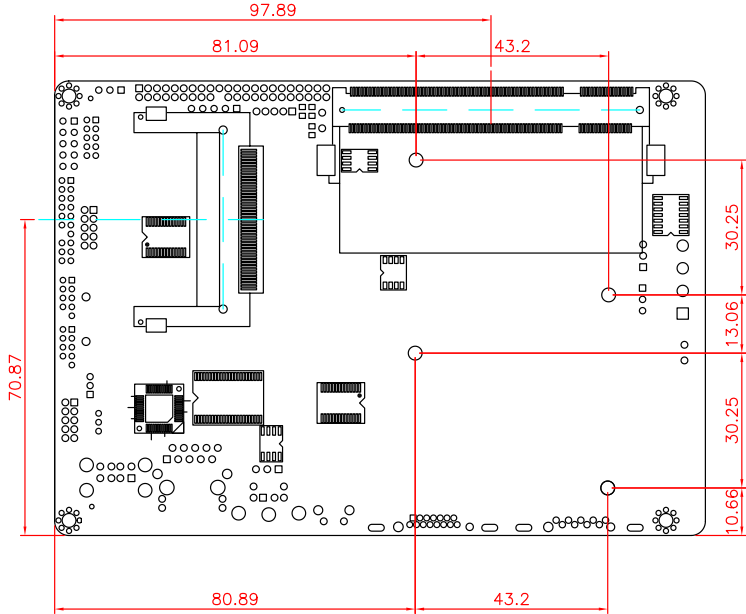

Unit:mm

1.11 Installing the Memory

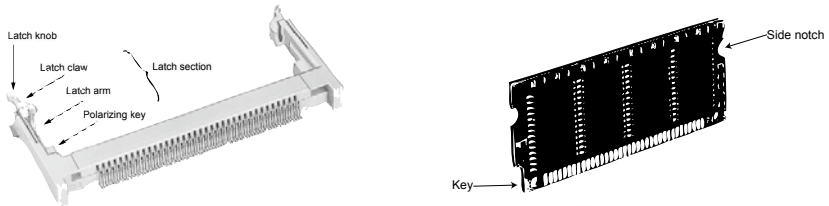

To install the Memory module, locate the Memory SO-DIMM slot on the board and perform as below:

1. Adjust the socket polarizing key and the board key to the same direction.
2. Insert the board obliquely. Moreover, lay the board in parallel to the opening at angle of 20° to 30° , and softly insert the board so as to hit the socket bottom. Stopping insertion halfway will result in improper insertion.
3. Applying the board side notch in parallel to the socket bottom so that the board position cannot be displaced, press the board side notch up, and fix it to the latch portion at both socket edges. Press the board side notch, and release the notch with a snap “click” tone, if the printed board exceeds the latch claw head.

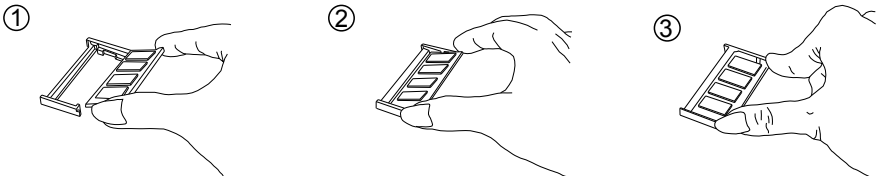

Procedures for board extraction

Apply the thumb nail to the latch knob at both socket edges. Forcibly widen the latch knobs to right and left ways, and release the latch. Then draw the board out along an angle where the board is raised.

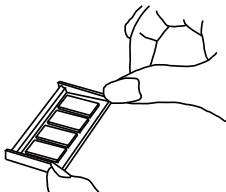

Chapter 2

Installation

2.1 Block Diagram

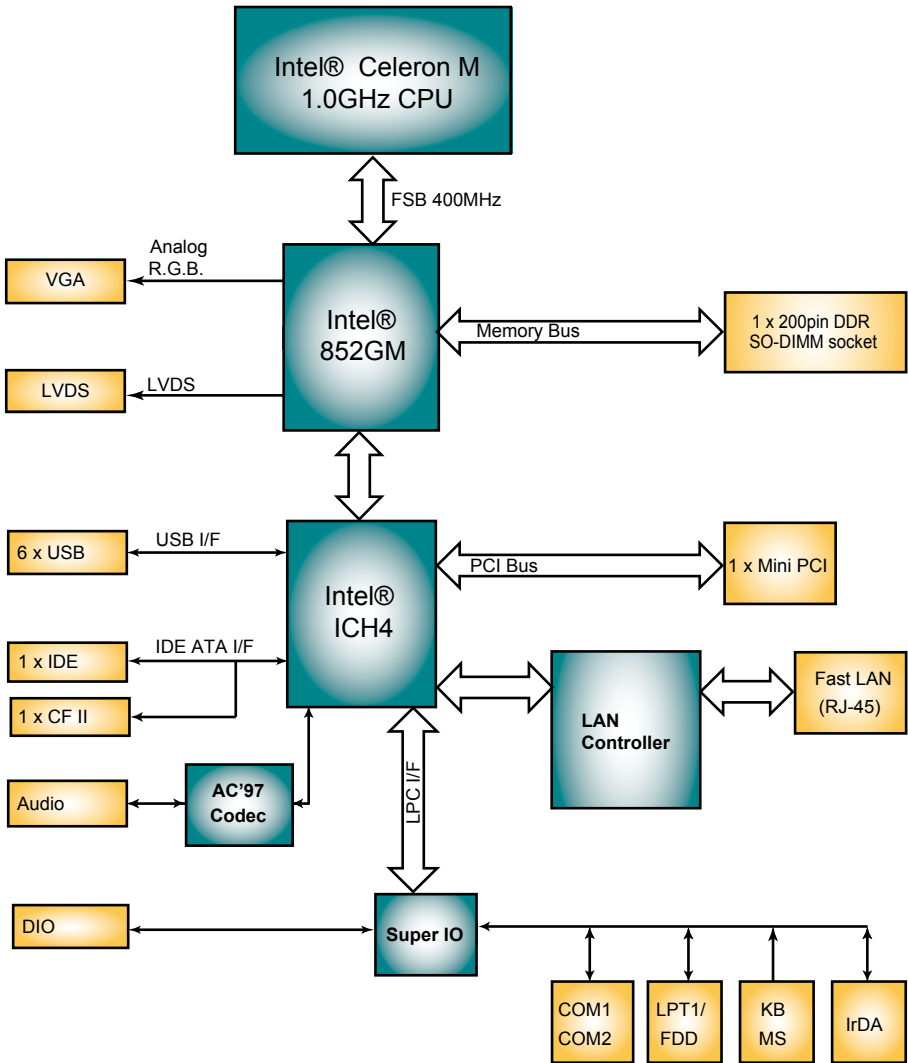

2.2 Jumpers and Connectors

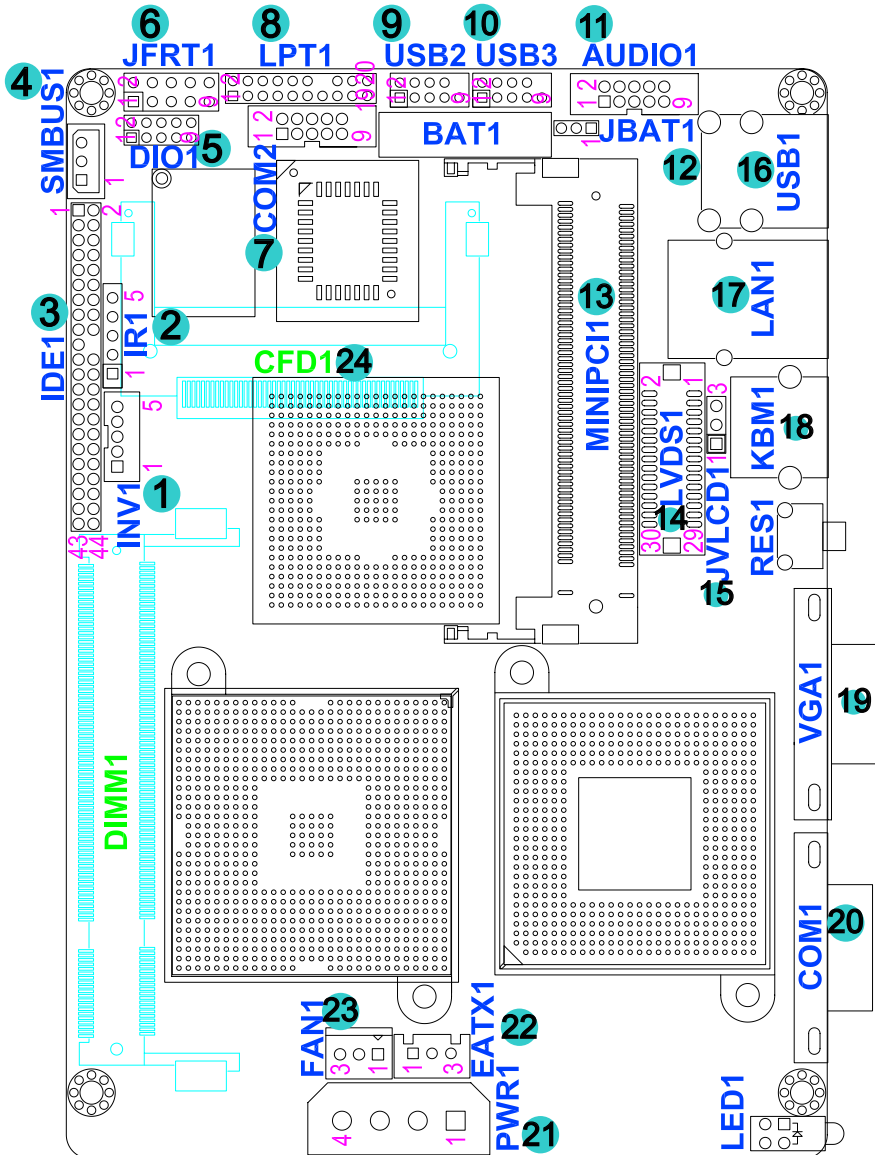



Jumpers

JBAT1: CMOS Setup (12)

If the board refuses to boot due to inappropriate CMOS settings here is how to proceed to clear (reset) the CMOS to its default values.

Connector type: 2.00mm pitch 1x3 pin header

Pin	Mode	
1-2	Keep CMOS (Default)	
2-3	Clear CMOS	

You may need to clear the CMOS if your system cannot boot up because you forgot your password, the CPU clock setup is incorrect, or the CMOS settings need to be reset to default values after the system BIOS has been updated.

Refer to the following solutions to reset your CMOS setting:

Solution A:

1. Power off the system and disconnect the power cable.
2. Place a shunt to short pin 1 and pin 2 of JBAT1 for five seconds.
3. Place the shunt back to pin 2 and pin 3 of JBAT1.
4. Power on the system.

Solution B:

If the CPU Clock setup is incorrect, you may not be able to boot up. In this case, follow these instructions:

1. Turn the system off, then on again. The CPU will automatically boot up using standard parameters.
2. As the system boots, enter BIOS and set up the CPU clock.



Note:

If you are unable to enter BIOS setup, turn the system on and off a few times.

JVLCD1: LCD Panel Voltage Select (15)

The voltage of LCD panel could be selected by JVLCD1 in +5V or +3.3V.

Connector type: 2.54mm pitch 1x3 pin header

Pin	Voltage	
1-2	+5V	
2-3	+3.3V (Default)	

Connectors

INV1: LCD Inverter Connector (1)

Connector type: 2.00mm pitch 1x5-pin box wafer connector.

Pin	Description
1	+12V
2	GND
3	Backlight on/off
4	Brightness control
5	GND

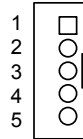

IR1: Infrared Connector (2)

Connector type: 2.54mm pitch 1x5 pin header

Pin	Description
1	+5V
2	N/C
3	IRRX
4	GND
5	IRTX

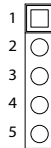

The IR connector can be configured to support wireless infrared module, user can transfer files to or from notebooks, PDA and printers.

Install infrared module onto IrDA connector and enable infrared function from BIOS setup and make sure to have correct orientation when you plug onto IrDA connector.

IDE1: IDE Connector (3)

An IDE drive ribbon cable has two connectors to support two IDE devices. If a ribbon cable connects to two IDE drives at the same time, one of them has to be configured as Master and the other has to be configured as Slave by setting the drive select jumpers on the drive.

Consult the documentation that came with your IDE drive for details on jumper locations and settings. You must orient the cable connector so that the pin 1 (color) edge of the cable corresponds to pin 1 of the IDE connector.

Connector type: 2.00mm pitch 2x22 pin header

Pin	Description	Pin	Description
1	IDE RESET	2	GND
3	DATA7	4	DATA8
5	DATA6	6	DATA9
7	DATA5	8	DATA10
9	DATA4	10	DATA11
11	DATA3	12	DATA12
13	DATA2	14	DATA13
15	DATA1	16	DATA14
17	DATA0	18	DATA15
19	GND	20	N/C (Key)
21	REQ	22	GND
23	IO WRITE	24	GND
25	IO READ	26	GND
27	IO READY	28	N/C
29	DACK	30	GND
31	IRQ14	32	N/C
33	ADDR1	34	ATA66 DETECT
35	ADDR0	36	ADDR2
37	CS#2	38	CS#3
39	IDEACTP	40	GND
41	+5V	42	+5V
43	GND	44	N/C

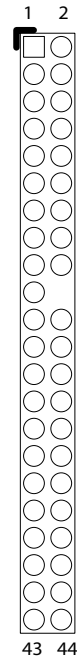

SMBUS1: External SMBUS Connector (4)

Connector type: 2.54mm pitch 1x3 box wafer connector.

Pin	Description
-----	-------------

1	Data
2	Clock
3	GND



DIO1: Digital I/O Connector (5)

DIO1 is a 8-bit DIO connector that supports 4-bit In/ 4-bit Out.

Connector type: 2.00 mm pitch 2x5 pin header

Pin	Description	Pin	Description
-----	-------------	-----	-------------

1	DIO1	2	DIO2
3	DIO3	4	DIO4
5	DIO5	6	DIO6
7	DIO7	8	DIO8
9	+5V	10	GND

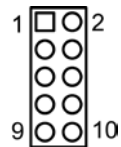

JFRT1: Switches and Indicators (6)

It provides connectors for system indicators that provides light indication of the computer activities and switches to change the computer status.

Connector type: 2.00 mm pitch 2x5 pin header

Pin	Description	Pin	Description
1	RESET+	2	RESET-
3	Power LED+	4	Power LED-
5	HDD LED+	6	HDD LED-
7	SPEAKER+	8	SPEAKER-
9	PSON+	10	PSON-

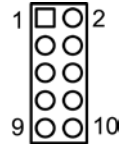

RES: Reset Button, pin 1-2.

This 2-pin connector connects to the case-mounted reset switch and is used to reboot the system.

PLED: Power LED Connector, pin 3-4.

This 2-pin connector connects to the case-mounted power LED. Power LED can be indicated when the CPU card is on or off. And keyboard lock can be used to disable the keyboard function so the PC will not respond by any input.

HLED: HDD LED Connector, pin 5-6.

This 2-pin connector connects to the case-mounted HDD LED to indicate hard disk activity.

SPK: External Speaker, pin 7-8.

This 2-pin connector connects to the case-mounted speaker.

PWRBTN: ATX soft power switch, pin 9-10.

This 2-pin connector connects to the case-mounted Power button.

COM2: RS-232 Connectors (7)

Connector type: 2.54mm pitch 2x5 box header.

Pin	Description	Pin	Description
1	DCD#	2	RXD
3	TXD	4	DTR#
5	GND	6	DSR#
7	RTS#	8	CTS#
9	RI#	10	N/C

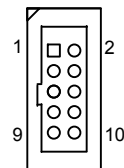

LPT1: Parallel Port or FDD Connector (8)

LPT1 is shared with FDD. Connector type: 2.00mm pitch 2x10 pin header.

Pin	Description	Pin	Description
1	STROBE	2	AFD
3	PTD0	4	ERROR
5	PTD1	6	INIT
7	PTD2	8	SLIN
9	PTD3	10	GND
11	PTD4	12	GND
13	PTD5	14	GND (Key)
15	PTD6	16	BUSY
17	PTD7	18	PE
19	ACK	20	SELECT



LPT1 can be configured as a connector floppy disk drive interface through BIOS setup.

Pin	Description	Pin	Description
1	N/C	2	RWC-
3	RINDEX-	4	HEAD-
5	TRAK0-	6	DIR-
7	WP-	8	STEP-
9	RDATA-	10	GND
11	DSKCHG-	12	GND
13	N/C	14	N/C
15	N/C	16	MOB-
17	N/C	18	WD-
19	DSB-	20	WE-

BIOS Setup

The default is to set LPT1 as FDD connector. To change the value, get into BIOS setup --> Integrated Peripheral --> Super IO Device.

BIOS Option	Setting	Description
External FDD Controller	Enabled	Set as FDD connector
Onboard Parallel Port	Disabled	
External FDD Controller	Disabled	
Onboard Parallel Port	378/IRQ7	Set as Parallel Port

USB2/ USB3: USB Connector (9), (10)

USB2/ USB3 supports four USB 2.0 w/ 480MB/s by 2.00mm pitch 2x5 pin header

Pin	Description	Pin	Description
1	+5V	2	+5V
3	USBD-	4	USBD-
5	USBD+	6	USBD+
7	GND	8	GND
9	GND	10	N/C (Key)

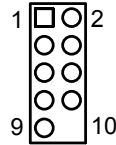

AUDIO1: Front Panel AUDIO Connector (11)

Connect a tape player or another audio source to the light blue Line-in connector to record audio on your computer or to play audio through your computer's sound chip and speakers.

Connect a micro-phone to the pink microphone connector to record audio to your computer.

Connector type: 2.00mm pitch 2x5 pin header.

Pin	Description	Pin	Description
1	Line-in Left	2	Line-in Right
3	GND	4	GND
5	MIC1	6	MIC2/N.C
7	GND	8	GND
9	Line-out Left	10	Line-out Right



MINIPCI1: MiniPCI slot (13)



LVDS1: LVDS LCD Connector (14)

The LVDS connector supports 18-bit or 36-bit LVDS. VDD could be selected by JVLCD1 in +5V or +3.3V. Connector type: DF-13-30DP-1.25V

Pin	Description	Pin	Description
1	VDD	2	VDD
3	TX2CLK+	4	TX1CLK+
5	TX2CLK-	6	TX1CLK-
7	GND	8	GND
9	TX2D0+	10	TX1D0+
11	TX2D0-	12	TX1D0-
13	GND	14	GND
15	TX2D1+	16	TX1D1+
17	TX2D1-	18	TX1D1-
19	GND	20	GND
21	TX2D2+	22	TX1D2+
23	TX2D2-	24	TX1D2-
25	GND	26	GND
27	TX2D3+	28	TX1D3+
29	TX2D3-	30	TX1D3-

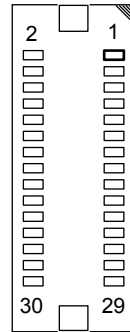

USB1: USB Stack Connector (16)

USB3 supports two USB 2.0 w/ 480MB/s by USB connector type A.

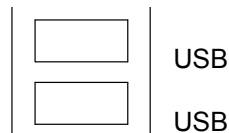

LAN1: 10/100 RJ-45 (17)

LAN2 supports 10/100 Mbps Fast Ethernet

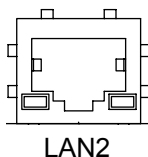

KBM1: Keyboard & Mouse (18)

Mini-Din Keyboard & Mouse connector

Pin	Description
1	KB Data
2	MS Data
3	GND
4	+5V
5	KB Clock
6	MS Clock

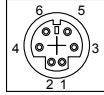

Note: KBM1 supports PS/2 keyboard directly, and PS/2 mouse supported with the additional PS/2 1-to-2 cable.

VGA1: CRT Connector (19)

Connector type: D-Sub 15-pin female.

Pin	Description	Pin	Description
1	RED	9	+5V
2	GREEN	10	GND
3	BLUE	11	N/C
4	N/C	12	VDDAT
5	GND	13	HSYNC
6	GND	14	VSYNC
7	GND	15	VDCLK
8	GND		

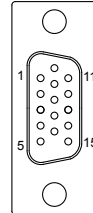

COM1: RS-232 Connector (20)

Connector type: D-Sub 9-pin male.

Pin	Description	Pin	Description
1	DCD#	6	DSR#
2	RXD	7	RTS#
3	TXD	8	CTS#
4	DTR#	9	RI#
5	GND		

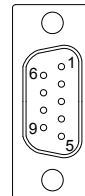

PWR1: Power Supply Connector (21)

Connector type: 5.08mm pitch 1x4-pin wafer connector

Pin	Description
1	+12V
2	GND
3	GND
4	+5V

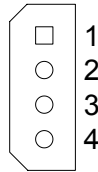

EATX1: ATX Feature Connector (22)

Connector type: 2.54mm pitch 1x3-pin box wafer connector

Pin	Description
1	PS-ON
2	GND
3	5V_SB



FAN1: CPU Fan Power Connector (23)

CPUF1 is 3-pin header for the system fan. The fan must be a +12V fan.

Pin	Description
1	GND
2	+12V
3	FAN_Detect



CFD1: Compact Flash II Socket (24)

Connector type: 50-pin compact flash connector

Pin	Description	Pin	Description
1	GND	26	N/C
2	SDD3	27	SDD11
3	SDD4	28	SDD12
4	SDD5	29	SDD13
5	SDD6	30	SDD14
6	SDD7	31	SDD15
7	SDCS1#	32	SDCS3#
8	GND	33	N/C
9	GND	34	SDIOR#
10	GND	35	SDIOW#
11	GND	36	+5V
12	GND	37	IRQ15
13	+5V	38	+5V
14	GND	39	CSEL#
15	GND	40	N/C
16	GND	41	IDERST2#
17	GND	42	SIORDY
18	SDA2	43	SDDREQ
19	SDA1	44	SDDACK#
20	SDA0	45	HD_LED2#
21	SDD0	46	SDIAG#
22	SDD1	47	SDD8
23	SDD2	48	SDD9
24	IOCS16#	49	SDD10
25	N/C	50	GND

The interface of Compact Flash socket is designated to use IDE2.

Installation instructions

Compact Flash (CF) card is “ not hot-swap ”. If the CF card is swapped in the condition of system power-on, it will damage the CF card.

1. Make sure the Single Board Computer is powered OFF.
2. Plug the Compact Flash Type II device into its socket. Verify the direction is correct.
3. Power up the system.

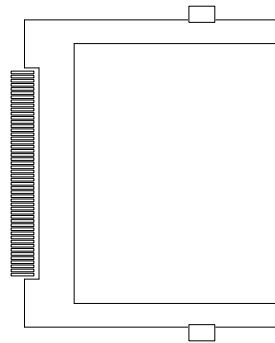

2.3 The Installation Paths of CD Driver

Driver	Path
AUDIO	\AUDIO\REALTEK\AC97
CHIPSET	\CHIPSET\INTEL\INF 6.3
LAN	\ETHERNET\INTEL\PRO 10&100
VGA	\GRAPHICS\INTEL\85X

3.15 BIOS Beep Sound code list

Beep Sound	Message
1 short (Beep)	System booting is normally
2 short (Beep)	CMOS setting error
1 long - 1 short (Beep)	DRAM error
1 long - 2 short (Beep)	Display card or monitor connected error
1 long - 3 short (Beep)	Keyboard error
1 long - 9 short (Beep)	ROM error
Long (Beep) continuous	DRAM hasn't inset correctly
Short (Beep) continuous	POWER supply has problem

3.16 BIOS memory mapping

Address	Device Description
E000:0000h - F000:FFFFh	System BIOS Area
D000:2000h - D000:FFFFh	Free space
D000:0000h - D000:1FFFh	LAN ROM
C000:E000h - CF00:FFFFh	Free space
C000:0000h - C000:DFFFh	VGA BIOS
A000:0000h - B000:FFFFh	VGA RAM
0000:0000h - 9000:FFFFh	DOS 640K

3.17 Award BIOS POST Codes

CFh	Test CMOS read/write functionality
C0h	Early chipset initialization: Disable shadow RAM, L2 cache (socket 7 and below), program basic chipset registers
C1h	Detect memory: Auto detection of DRAM size, type and ECC, auto detection of L2 cache (socket 7 and below)
C3h	Expand compressed BIOS code to DRAM
C5h	Call chipset hook to copy BIOS back to E000 & F000 shadow RAM
01h	Expand the Xgroup codes located in physical memory address 1000:0
02h	Reserved
03h	Initial Superio_Early_Init switch
04h	Reserved
05h	Blank out screen; Clear CMOS error flag
06h	Reserved
07h	Clear 8042 interface; Initialize 8042 self test
08h	Test special keyboard controller for Winbond 977 series Super I/O chips; Enable keyboard interface
09h	Reserved
0Ah	Disable PS/2 mouse interface (optional); Auto detect ports for keyboard & mouse followed by a port & interface swap (optional); Reset keyboard for Winbond 977 series Super I/O chips
0Bh	Reserved
0Ch	Reserved
0Dh	Reserved
0Eh	Test F000h segment shadow to see whether it is read/write capable or not. If test fails, keep beeping the speaker
0Fh	Reserved
10h	Auto detect flash type to load appropriate flash read/write codes into the run time area in F000 for ESCD & DMI support
11h	Reserved
12h	Use walking 1's algorithm to check out interface in CMOS circuitry. Also set real time clock power status and then check for override
13h	Reserved
14h	Program chipset default values into chipset. Chipset default values are MODBINable by OEM customers
15h	Reserved
16h	Initial Early_Init_Onboard_Generator switch
17h	Reserved
18h	Detect CPU information including brand, SMI type (Cyrix or Intel) and CPU level (586 or 686)
19h	Reserved
1Ah	Reserved
1Bh	Initial interrupts vector table. If no special specified, all H/W interrupts are directed to SPURIOUS_INT_HDLR & S/W interrupts to SPURIOUS_soft_HDLR
1Ch	Reserved
1Dh	Initial EARLY_PM_INIT switch
1Eh	Reserved
1Fh	Load keyboard matrix (notebook platform)

BIOS

20h	Reserved
21h	HPM initialization (notebook platform)
22h	Reserved
23h	Check validity of RTC value; Load CMOS settings into BIOS stack. If CMOS checksum fails, use default value instead; Prepare BIOS resource map for PCI & PnP use. If ESCD is valid, take into consideration of the ESCD's legacy information; Onboard clock generator initialization. Disable respective clock resource to empty PCI & DIMM slots; Early PCI initialization - Enumerate PCI bus number, assign memory & I/O resource, search for a valid VGA device & VGA BIOS, and put it into C000:0
24h	Reserved
25h	Reserved
26h	Reserved
27h	Initialize INT 09 buffer
28h	Reserved
29h	Program CPU internal MTRR (P6 & PII) for 0-640K memory address; Initialize the APIC for Pentium class CPU; Program early chipset according to CMOS setup; Measure CPU speed; Invoke video BIOS
2Ah	Reserved
2Bh	Reserved
2Ch	Reserved
2Dh	Initialize multilanguage; Put information on screen display, including Award title, CPU type, CPU speed, etc...
2Eh	Reserved
2Fh	Reserved
30h	Reserved
31h	Reserved
32h	Reserved
33h	Reset keyboard except Winbond 977 series Super I/O chips
34h	Reserved
35h	Reserved
36h	Reserved
37h	Reserved
38h	Reserved
39h	Reserved
3Ah	Reserved
3Bh	Reserved
3Ch	Test 8254
3Dh	Reserved
3Eh	Test 8259 interrupt mask bits for channel 1
3Fh	Reserved
40h	Test 9259 interrupt mask bits for channel 2
41h	Reserved
42h	Reserved
43h	Test 8259 functionality
44h	Reserved
45h	Reserved
46h	Reserved

47h	Initialize EISA slot
48h	Reserved
49h	Calculate total memory by testing the last double last word of each 64K page; Program writes allocation for AMD K5 CPU
4Ah	Reserved
4Bh	Reserved
4Ch	Reserved
4Dh	Reserved
4Eh	Program MTRR of M1 CPU; initialize L2 cache for P6 class CPU & program cacheable range; Initialize the APIC for P6 class CPU; On MP platform, adjust the cacheable range to smaller one in case the cacheable ranges between each CPU are not identical
4Fh	Reserved
50h	Initialize USB
51h	Reserved
52h	Test all memory (clear all extended memory to 0)
53h	Reserved
54h	Reserved
55h	Display number of processors (multi-processor platform)
56h	Reserved
57h	Display PnP logo; Early ISA PnP initialization and assign CSN to every ISA PnP device
58h	Reserved
59h	Initialize the combined Trend Anti-Virus code
5Ah	Reserved
5Bh	Show message for entering AWDFLASH.EXE from FDD (optional feature)
5Ch	Reserved
5Dh	Initialize Init_Onboard_Super_IO switch; Initialize Init_Onboard_AUDIO switch
5Eh	Reserved
5Fh	Reserved
60h	Okay to enter Setup utility
61h	Reserved
62h	Reserved
63h	Reserved
64h	Reserved
65h	Initialize PS/2 mouse
66h	Reserved
67h	Prepare memory size information for function call: INT 15h ax=E820h
68h	Reserved
69h	Turn on L2 cache
6Ah	Reserved
6Bh	Program chipset registers according to items described in Setup & Auto-Configuration table
6Ch	Reserved
6Dh	Assign resources to all ISA PnP devices; Auto assign ports to onboard COM ports if the corresponding item in Setup is set to "AUTO"
6Eh	Reserved
6Fh	Initialize floppy controller; Setup floppy related fields in 40:hardware

BIOS

70h	Reserved
71h	Reserved
72h	Reserved
73h	Enter AWDFLASH.EXE if: AWDFLASH.EXE is found in floppy drive and ALT+F2 is pressed
74h	Reserved
75h	Detect and install all IDE devices: HDD, LS120, ZIP, CDROM...
76h	Reserved
77h	Detect serial ports and parallel ports
78h	Reserved
79h	Reserved
7Ah	Detect and install coprocessor
7Bh	Reserved
7Ch	Reserved
7Dh	Reserved
7Eh	Reserved
7Fh	Switch back to text mode if full screen logo is supported: if errors occur, report errors & wait for keys, if no errors occur or F1 key is pressed continue - Clear EPA or customization logo
80h	Reserved
81h	Reserved
82h	Call chipset power management hook: Recover the text font used by EPA logo (not for full screen logo), If password is set, ask for password
83h	Save all data in stack back to CMOS
84h	Initialize ISA PnP boot devices
85h	Final USB initialization; NET PC: Build SYSID structure; Switch screen back to text mode; Set up ACPI table at top of memory; Invoke ISA adapter ROM's; Assign IRQ's to PCI devices; Initialize APM; Clear noise of IRQ's
86h	Reserved
87h	Reserved
88h	Reserved
89h	Reserved
90h	Reserved
91h	Reserved
92h	Reserved
93h	Read HDD boot sector information for Trend Anti-Virus code
94h	Enable L2 cache; Program boot up speed; Chipset final initialization; Power management final initialization; Clear screen and display summary table; Program K6 write allocation; Program P6 class write combining
95h	Program daylight saving; Update keyboard LED and typematic rate
96h	Build MP table; Build and update ESCD; Set CMOS century to 20h or 19h; Load CMOS time into DOS timer tick; Build MSIRQ routing table
FFh	Boot attempt (INT 19h)

Chapter 4

Appendix

4.1 I/O Port Address Map

Each peripheral device in the system is assigned a set of I/O port addresses which also becomes the identity of the device.

The following table lists the I/O port addresses used.

Address	Device Description
00000000 - 0000000F	DMA Controller
00000080 - 0000009F	DMA Controller
000000C0 - 000000DF	DMA Controller
00000020 - 00000021	Programmable Interrupt Controller
000000A0 - 000000A1	Programmable Interrupt Controller
00000040 - 00000043	System Timer
00000044 - 00000047	System Timer
00000060 - 00000064	Keyboard Controller
00000070 - 00000073	System CMOS/Real Time Clock
000000F0 - 000000FF	Math Co-processor
000001F0 - 000001F7	Primary IDE
00000274 - 00000277	ISAPNP Read Data Port
00000279, 00000A79	ISAPNP Configuration
000002F8 - 000002FF	Communications Port (COM2, If use)
00000378 - 0000037A	Parallel Port (If use)
000003B0 - 000003BF	MDA/MGA
000003C0 - 000003CF	EGA/VGA
000003D4 - 000003D9	CGA CRT register
000003F0 - 000003F7	Floppy Diskette
000003F6 - 000003F6	Primary IDE
000003F8 - 000003FF	Communications Port (COM1, If use)
00000400 - 0000041F	South Bridge SMB
000004D0 - 000004D1	IRQ Edge/Level Control Ports
00000500 - 0000053F	South Btidge GPIO
00000800 - 0000087F	ACPI
00000A00 - 00000A07	PME

00000A10 - 00000A17	Hardware Monitor
00000CF8	PCI Configuration Address
00000CFC	PCI Configuration Data

4.2 Interrupt Request Lines (IRQ)

Peripheral devices use interrupt request lines to notify CPU for the service required. The following table shows the IRQ used by the devices on board.

Level	Function
IRQ 0	System Timer
IRQ 1	Keyboard Controller
IRQ 2	VGA and Link to Secondary PIC
IRQ 3	Communications Port (COM2)
IRQ 4	Communications Port (COM1)
IRQ 5	PCI Device
IRQ 6	Standard Floppy Disk Controller
IRQ 7	Parallel Port
IRQ 8	System CMOS/real time clock
IRQ 9	Microsoft ACPI-Compliant System
IRQ 10	PCI Device
IRQ 11	PCI Device
IRQ 12	PS/2 Compatible Mouse
IRQ 13	FPU Exception
IRQ 14	IDE Controller
IRQ 15	PCI Device

4.3 BIOS memory mapping

Address	Device Description
00000h - 9FFFFh	DOS Kernel Area
A0000h, BFFFFh	EGA and VGA Video Buffer (128KB)
C00000h - CFFFFh	EGA/VGA ROM
D0000h - DFFFFh	Adaptor ROM
E00000h - FFFFFh	System BIOS

Any advice or comments about our products and service, or anything we can help you with please don't hesitate to contact us. We will do our best to support your products, projects and business.



Address: Global American, Inc.
17 Hampshire Drive
Hudson, NH 03051

Telephone: Toll Free (U.S. Only) 800-833-8999
(603)886-3900

FAX: (603)886-4545

Website: <http://www.globalamericaninc.com>
Support: Technical Support at Global American

