



integration with integrity

3308440 **User's Manual**

EPIC ATOM SBC

Version 1.0

Copyrights

This document is copyrighted and all rights are reserved. It does not allow any non authorization in copied, photocopied, translated or reproduced to any electronic or machine readable form in whole or in part without prior written consent from the manufacturer.

In general, the manufacturer will not be liable for any direct, indirect, special, incidental or consequential damages arising from the use of inability to use the product or documentation, even if advised of the possibility of such damages. The manufacturer keeps the rights in the subject to change the contents of this document without prior notices in order to improve the function design, performance, quality and reliability. The author assumes no responsibility for any errors or omissions, which may appear in this document, nor does it make a commitment to update the information contained herein.

Trademarks

Intel is a registered trademark of Intel Corporation.

Award is a registered trademark of Award Software, Inc.

All other trademarks, products and or product's name mentioned herein are mentioned for identification purposes only, and may be trademarks and/or registered trademarks of their respective companies or owners.

Packing List

The items listed below should all be included in the 3308440 package.

- 1 x 3308440 Single Board Computer
- 2 x RS-232 cable (P/N: 32200-000049-RS)
- 2 x SATA Cable (P/N: 32000-062800-RS)
- 1 x KB/MS Cable (P/N: 32000-000138-RS)
- 1 x Power Cable (P/N: 32100-087100-RS)
- 1 x Mini Jumper
- 1 x Utility CD
- 1 x QIG (Quick Installation Guide)

Images of the above items are shown in **Chapter 3**.

1	INTRODUCTION.....	1
1.1	OVERVIEW	2
1.1.1	3308440 Introduction.....	2
1.2	3308440 EPIC OVERVIEW	2
1.2.1	3308440 Overview Photo.....	2
1.2.2	3308440 Peripheral Connectors and Jumpers.....	4
1.2.3	Technical Specifications.....	5
2	DETAILED SPECIFICATIONS	8
2.1	DIMENSIONS	9
2.1.1	Board Dimensions.....	9
2.1.2	External Interface Panel Dimensions	10
2.2	DATA FLOW	10
2.3	EMBEDDED ATOM PROCESSOR	11
2.3.1	Overview	11
2.3.2	Features	12
2.3.3	Front Side Bus (FSB)	13
2.4	INTEL 945GSE NORTHBRIDGE CHIPSET.....	14
2.4.1	Intel® 945GSE Overview.....	14
2.4.2	Intel® 945GSE DDR2 Controller.....	14
2.4.3	Intel® 945GSE Graphics.....	15
2.4.3.1	Analog CRT Graphics Mode.....	15
2.4.3.2	LVDS Interface	16
2.4.3.3	TV Out Interface	17
2.4.3.4	Chrontel CH7308B SDVO / LVDS Support.....	17
2.5	INTEL® ICH7-M SOUTHBRIDGE CHIPSET.....	18
2.5.1	Intel® ICH7-M Overview	18
2.5.2	Intel® ICH7-M Audio Controllers.....	19
2.5.2.1	Intel® ICH7-M Audio Codec '97 Controller.....	19
2.5.2.2	Intel® ICH7-M High Definition (HD) Audio Controller	20
2.5.3	Intel® ICH7-M IDE Interface.....	20

2.5.4 Intel® ICH7-M Low Pin Count (LPC) Interface	21
2.5.5 Intel® ICH7-M PCI Interface.....	21
2.5.6 Intel® ICH7-M PCIe Bus	22
2.5.6.1 PCIe GbE Ethernet.....	22
2.5.6.2 PCIe Mini Expansion Slot	24
2.5.7 Intel® ICH7-M Real Time Clock	25
2.5.8 Intel® ICH7-M SATA Controller	25
2.5.9 Intel® ICH7-M USB Controller.....	26
2.6 LPC BUS COMPONENTS.....	27
2.6.1 LPC Bus Overview.....	27
2.6.2 BIOS Chipset.....	27
2.6.3 iTE IT8718F Super I/O chipset.....	28
2.6.3.1 Super I/O LPC Interface	29
2.6.3.2 Super I/O 16C550 UARTs	29
2.6.3.3 Super I/O Digital Input/Output	29
2.6.3.4 Super I/O Enhanced Hardware Monitor	29
2.6.3.5 Super I/O Fan Speed Controller.....	29
2.6.3.6 Super I/O Keyboard/Mouse Controller.....	30
2.6.3.7 Super I/O Parallel Port	30
2.6.4 Fintek F81216DG LPC Serial Port Chipset.....	30
2.7 ENVIRONMENTAL AND POWER SPECIFICATIONS	31
2.7.1 System Monitoring	31
2.7.2 Operating Temperature and Temperature Control.....	31
2.7.3 Power Consumption.....	32
3 UNPACKING	33
3.1 ANTI-STATIC PRECAUTIONS.....	34
3.2 UNPACKING.....	34
3.2.1 Unpacking Precautions.....	34
3.3 UNPACKING CHECKLIST.....	35
3.3.1 Package Contents.....	35
3.3.2 Optional Items.....	36
4 CONNECTORS	38
4.1 PERIPHERAL INTERFACE CONNECTORS	39

4.1.1	3308440 Layout.....	39
4.2	PERIPHERAL INTERFACE CONNECTORS	40
4.2.1	External Interface Panel Connectors.....	41
4.3	INTERNAL PERIPHERAL CONNECTORS.....	42
4.3.1	5V Power Connector.....	42
4.3.2	AT Power Connector.....	43
4.3.3	ATX Power Supply Enable Connector	44
4.3.4	Audio Connector (9-pin)	45
4.3.5	Backlight Inverter Connector	46
4.3.6	CompactFlash® Socket.....	47
4.3.7	Digital Input/Output (DIO) Connector.....	49
4.3.8	Fan Connector (+12V, 3-pin)	50
4.3.9	Front Panel Connector (8-pin)	51
4.3.10	IDE Connector(44-pin).....	52
4.3.11	Infrared Interface Connector (5-pin)	54
4.3.12	Keyboard/Mouse Connector	55
4.3.13	LVDS LCD Connector	56
4.3.14	Parallel Port Connector	57
4.3.15	PCIe Mini Card Slot	58
4.3.16	PCI-104 Slot.....	60
4.3.17	SATA Drive Connectors	63
4.3.18	Serial Port Connectors (COM 3 and COM4).....	64
4.3.19	Serial Port Connector (COM 2)(RS-232, RS-422 or RS-485).....	64
4.3.20	TV Out Connector	65
4.3.21	USB Connectors (Internal)	66
4.4	EXTERNAL PERIPHERAL INTERFACE CONNECTOR PANEL	67
4.4.1	Keyboard/Mouse Connector	68
4.4.2	LAN Connectors.....	69
4.4.3	Serial Port Connector (COM1)	70
4.4.4	USB Connectors.....	71
4.4.5	VGA Connector	71
5	INSTALLATION	73
5.1	ANTI-STATIC PRECAUTIONS.....	74
5.2	INSTALLATION CONSIDERATIONS	75

5.2.1 Installation Notices	75
5.2.2 Installation Checklist	76
5.3 UNPACKING.....	77
5.4 SO-DIMM AND CF CARD INSTALLATION.....	77
5.4.1 SO-DIMM Installation	77
5.4.2 CF Card Installation.....	78
5.5 JUMPER SETTINGS	79
5.5.1 AT Power Select Jumper Settings.....	80
5.5.2 CF Card Setup	81
5.5.3 Clear CMOS Jumper.....	82
5.5.4 COM 2 Function Select Jumper.....	83
5.5.5 LVDS1 Panel Resolution Jumper.....	84
5.5.6 LVDS Voltage Selection.....	86
5.5.7 PCI-104 Voltage Setup.....	87
5.6 CHASSIS INSTALLATION	88
5.6.1 Airflow.....	88
5.6.2 Motherboard Installation.....	89
5.7 INTERNAL PERIPHERAL DEVICE CONNECTIONS.....	89
5.7.1 Peripheral Device Cables	89
5.7.2 AT Power Connection	90
5.7.3 5.1 Channel Audio Kit Installation	91
5.7.4 7.1 Channel Audio Kit Installation	93
5.7.5 ATA Flat Cable Connection	94
5.7.6 SATA Drive Connection	95
5.7.7 Single RS-232 Cable (w/o Bracket)	97
5.7.8 USB Cable (Dual Port without Bracket)	98
5.7.9 Parallel Port Cable without Bracket	99
5.7.10 Dual RS-422/485 Cables.....	101
5.8 EXTERNAL PERIPHERAL INTERFACE CONNECTION	102
5.8.1 LAN Connection (Single Connector)	103
5.8.2 PS/2 Y-Cable Connection.....	103
5.8.3 Serial Device Connection	104
5.8.4 USB Connection (Dual Connector)	105
5.8.5 VGA Monitor Connection	106

6	BIOS SCREENS.....	108
6.1	INTRODUCTION	109
6.1.1	<i>Starting Setup</i>	109
6.1.2	<i>Using Setup</i>	109
6.1.3	<i>Getting Help</i>	110
6.1.4	<i>Unable to Reboot After Configuration Changes</i>	110
6.1.5	<i>BIOS Menu Bar</i>	110
6.2	MAIN	111
6.3	ADVANCED.....	112
6.3.1	<i>CPU Configuration</i>	113
6.3.2	<i>IDE Configuration</i>	114
6.3.2.1	<i>IDE Master, IDE Slave</i>	116
6.3.3	<i>Super IO Configuration</i>	122
6.3.4	<i>Hardware Health Configuration</i>	126
6.3.5	<i>Power Configuration</i>	130
6.3.5.1	<i>ACPI configuration</i>	131
6.3.5.2	<i>APM Configuration</i>	132
6.3.6	<i>Remote Configuration</i>	135
6.3.7	<i>USB Configuration</i>	139
6.4	PCI/PNP	141
6.5	BOOT	144
6.5.1	<i>Boot Settings Configuration</i>	144
6.5.2	<i>Boot Device Priority</i>	147
6.6	SECURITY.....	148
6.7	CHIPSET	149
6.7.1	<i>North Bridge Chipset Configuration</i>	150
6.7.2	<i>SouthBridge Configuration</i>	153
6.8	EXIT.....	154
7	SOFTWARE DRIVERS	156
7.1	AVAILABLE SOFTWARE DRIVERS	157
7.2	STARTING THE DRIVER PROGRAM	157
7.3	CHIPSET DRIVER INSTALLATION.....	159
7.4	VGA DRIVER INSTALLATION	164
7.5	LAN DRIVER INSTALLATION	169

7.6 AUDIO DRIVER INSTALLATION	171
7.6.1 HD Audio Installation.....	172
7.6.2 AC'97 Driver Installation.....	175
A BIOS MENU OPTIONS.....	179
B TERMINOLOGY	183
C DIO INTERFACE.....	188
C.1 DIO INTERFACE INTRODUCTION	189
C.2 DIO CONNECTOR PINOUTS	189
C.3 ASSEMBLY LANGUAGE SAMPLES.....	190
C.3.1 Enable the DIO Input Function.....	190
C.3.2 Enable the DIO Output Function.....	190
D WATCHDOG TIMER.....	191
E ADDRESS MAPPING	194
E.1 I/O ADDRESS MAP.....	195
E.2 IRQ ADDRESS MAP	197
E.3 MEMORY ADDRESS MAP.....	198
F HAZARDOUS MATERIALS DISCLOSURE	199
F.1 HAZARDOUS MATERIAL DISCLOSURE TABLE FOR IPB PRODUCTS CERTIFIED AS ROHS COMPLIANT UNDER 2002/95/EC WITHOUT MERCURY.....	200
G INDEX	203

List of Figures

Figure 1-1: 3308440.....	2
Figure 1-2: 3308440 SBC Overview [Front View]	3
Figure 1-3: 3308440 SBC Overview [Solder Side].....	4
Figure 2-1: 3308440 SBC Dimensions (mm).....	10
Figure 2-2: External Interface Panel Dimensions (mm).....	10
Figure 2-3: Data Flow Block Diagram.....	11
Figure 2-4: Embedded Processor Covered by Heat Sink.....	12
Figure 2-5: Front Side Bus	13
Figure 2-6: DDR2 SO-DIMM Socket	14
Figure 2-7: VGA Connector	16
Figure 2-8: Chrontel SDVO-to-LVDS DAC Chipset.....	18
Figure 2-9: IDE Connector.....	20
Figure 2-10: PCI-104 Connector.....	22
Figure 2-11: Realtek PCI GbE Controllers	23
Figure 2-12: PCIe Mini Slot.....	25
Figure 2-13: SATA Connectors	26
Figure 2-14: Onboard USB Implementation	27
Figure 2-15: Super I/O.....	28
Figure 4-1: Connector and Jumper Locations [Front Side].....	39
Figure 4-2: Connector and Jumper Locations [Solder Side].....	40
Figure 4-3: 5V Power Connector Pinouts	43
Figure 4-4: AT Power Connector Location	44
Figure 4-5: ATX Power Supply Enable Connector Location.....	45
Figure 4-6: Audio Connector Location (9-pin)	46
Figure 4-7: Panel Backlight Connector Pinout Locations.....	47
Figure 4-8: CF Card Socket Location.....	48
Figure 4-9: DIO Connector Connector Locations	49
Figure 4-10: +12V Fan Connector Location.....	51

Figure 4-11: Front Panel Connector Pinout Locations (8-pin)	52
Figure 4-12: Secondary IDE Device Connector Locations.....	53
Figure 4-13: Infrared Connector Pinout Locations	54
Figure 4-14: Keyboard/Mouse Connector Location.....	55
Figure 4-15: LVDS LCD Connector Pinout Locations	56
Figure 4-16: Parallel Port Connector Location.....	58
Figure 4-17: PCIe Mini Card Slot Location	59
Figure 4-18: PCI-104 Slot Location.....	61
Figure 4-19: SATA Drive Connector Locations	63
Figure 4-20: COM Connector Pinout Locations	64
Figure 4-21: RS-232/422/485 Serial Port Connector Location	65
Figure 4-22: TV Connector Pinout Locations	66
Figure 4-23: USB Connector Pinout Locations	67
Figure 4-24: External Peripheral Interface Connector	68
Figure 4-25: PS/2 Pinout and Configuration.....	68
Figure 4-26: RJ-45 Ethernet Connector	69
Figure 4-27: COM1 Pinout Locations	70
Figure 4-28: VGA Connector	72
Figure 5-1: SO-DIMM Installation.....	77
Figure 5-2: CF Card Installation.....	79
Figure 5-3: Jumper Locations	79
Figure 5-4: AT Power Select Jumper Location	81
Figure 5-5: CF Card Setup Jumper Location.....	82
Figure 5-6: Clear CMOS Jumper	83
Figure 5-7: COM 2 Function Select Jumper Location	84
Figure 5-8:LVDS Panel Resolution Jumper Pinout Locations	85
Figure 5-9: LVDS Voltage Selection Jumper Pinout Locations.....	87
Figure 5-10: PCI-104 Voltage Setup Jumper Pinout Locations	88
Figure 5-11: Power Cable to Motherboard Connection.....	90
Figure 5-12: Connect Power Cable to Power Supply	91
Figure 5-13: 5.1 Channel Audio Kit.....	92
Figure 5-14: 7.1 Channel Audio Kit.....	94

Figure 5-15: IDE Cable Connection	95
Figure 5-16: SATA Drive Cable Connection	96
Figure 5-17: SATA Power Drive Connection	97
Figure 5-18: Single RS-232 Cable Installation	98
Figure 5-19: Dual USB Cable Connection.....	99
Figure 5-20: LPT Cable Connection	100
Figure 5-21: Connect the LPT Device.....	101
Figure 5-22: Dual Serial Port Connector Cable Connection	102
Figure 5-23: LAN Connection.....	103
Figure 5-24: PS/2 Keyboard/Mouse Connector	104
Figure 5-25: Serial Device Connector	105
Figure 5-26: USB Connector	106
Figure 5-27: VGA Connector	107
Figure 7-1: Start Up Screen.....	158
Figure 7-2: Select Operating System	158
Figure 7-3: Drivers.....	159
Figure 7-4: Chipset Driver Screen	160
Figure 7-5: Chipset Driver Welcome Screen	160
Figure 7-6: Chipset Driver License Agreement.....	161
Figure 7-7: Chipset Driver Read Me File	162
Figure 7-8: Chipset Driver Setup Operations	163
Figure 7-9: Chipset Driver Installation Finish Screen	164
Figure 7-10: VGA Driver Read Me File.....	165
Figure 7-11: VGA Driver Setup Files Extracted	165
Figure 7-12: VGA Driver Welcome Screen.....	166
Figure 7-13: VGA Driver License Agreement	167
Figure 7-14: VGA Driver Read Me File.....	167
Figure 7-15: VGA Driver Setup Operations	168
Figure 7-16: VGA Driver Installation Finish Screen.....	168
Figure 7-17: LAN Driver Welcome Screen	169
Figure 7-18: LAN Driver Welcome Screen	170
Figure 7-19: LAN Driver Installation.....	170

Figure 7-20: LAN Driver Installation Complete	171
Figure 7-21: Audio Driver Options.....	172
Figure 7-22: Extract HD Audio Driver Installation Files	173
Figure 7-23: HD Audio Driver Welcome Screen	174
Figure 7-24: System Update.....	175
Figure 7-25: AC'97 Driver Installation File Extraction	176
Figure 7-26: AC'97 Driver Installation Welcome Screen	176
Figure 7-27: AC'97 Driver Installation Verification.....	177
Figure 7-28: AC'97 Driver Installation	177
Figure 7-29: AC'97 Driver Installation Complete.....	178

List of Tables

Table 1-1: Technical Specifications	7
Table 2-1: Supported HDD Specifications	21
Table 2-2: Power Consumption	32
Table 4-1: Peripheral Interface Connectors.....	41
Table 4-2: Rear Panel Connectors.....	42
Table 4-3: 5V Power Connector Pinouts	43
Table 4-4: AT Power Connector Pinouts	44
Table 4-5: ATX Power Supply Enable Connector Pinouts	45
Table 4-6: Audio Connector Pinouts (9-pin).....	46
Table 4-7: Panel Backlight Connector Pinouts	47
Table 4-8: CF Card Socket Pinouts	49
Table 4-9: DIO Connector Connector Pinouts.....	50
Table 4-10: +12V Fan Connector Pinouts	51
Table 4-11: Front Panel Connector Pinouts (8-pin)	52
Table 4-12: Secondary IDE Connector Pinouts.....	54
Table 4-13: Infrared Connector Pinouts.....	55
Table 4-14: Keyboard/Mouse Connector Pinouts	56
Table 4-15: LVDS LCD Port Connector Pinouts.....	57
Table 4-16: Parallel Port Connector Pinouts	58
Table 4-17: PCIe Mini Card Slot Pinouts	60
Table 4-18: PCI-104 Slot Connector Pinouts	62
Table 4-19: SATA Drive Connector Pinouts	63
Table 4-20: COM Connector Pinouts.....	64
Table 4-21: RS-232/RS-485 Serial Port Connector Pinouts.....	65
Table 4-22: TV Port Connector Pinouts	66
Table 4-23: USB Port Connector Pinouts	67
Table 4-24: Keyboard Connector Pinouts	69
Table 4-25: LAN Pinouts	69

Table 4-26: RJ-45 Ethernet Connector LEDs.....	70
Table 4-27: RS-232 Serial Port (COM 1) Pinouts	70
Table 4-28: USB Port Pinouts	71
Table 4-29: VGA Connector Pinouts	72
Table 5-1: Jumpers.....	80
Table 5-2: AT Power Select Jumper Settings.....	81
Table 5-3: CF Card Setup Jumper Settings	82
Table 5-4: Clear CMOS Jumper Settings	83
Table 5-5: COM 2 Function Select Jumper Settings.....	84
Table 5-6: LVDS Panel Resolution Jumper Settings	85
Table 5-7: LVDS Voltage Selection Jumper Settings	86
Table 5-8: PCI-104 Voltage Setup Jumper Settings.....	87
Table 5-9: Provided Cables.....	89
Table 6-1: BIOS Navigation Keys.....	110

List of BIOS Menus

Menu 1: Main.....	111
Menu 2: Advanced.....	113
Menu 3: CPU Configuration	114
Menu 4: IDE Configuration	115
Menu 5: IDE Master and IDE Slave Configuration	117
Menu 6: Super IO Configuration	122
Menu 7: Hardware Health Configuration	127
Menu 8: Power Configuration	131
Menu 9: ACPI Configuration	132
Menu 10:Advanced Power Management Configuration.....	133
Menu 11: Remote Access Configuration [Advanced]	136
Menu 12: USB Configuration	140
Menu 13: PCI/PnP Configuration	142
Menu 14: Boot.....	144
Menu 15: Boot Settings Configuration.....	145
Menu 16: Boot Device Priority Settings	147
Menu 17: Security.....	148
Menu 18: Chipset.....	149
Menu 19:North Bridge Chipset Configuration.....	150
Menu 20:SouthBridge Chipset Configuration	153
Menu 21:Exit	154

Chapter

1

Introduction

1.1 Overview

1.1.1 3308440 Introduction

The 3308440 EPIC motherboards are embedded 45 nm Intel® Atom™ processor platforms. The Intel® Atom™ processor N270 embedded on the 3308440 has a 1.60 GHz clock speed, a 533 MHz FSB and a 512 KB L2 cache. The 3308440 also supports one 200-pin 533 MHz 2.0 GB (max.) DDR2 SDRAM SO-DIMM. The standard model comes with a single 18-bit dual-channel LVDS connector and the 3308440B model comes with an additional 24-bit dual channel LVDS connector.

The 3308440 also comes with two PCI Express (PCIe) Gigabit Ethernet (GbE) connectors, a PCI-104 expansion slot and a PCIe mini slot on the solder side.

1.2 3308440 Overview

1.2.1 3308440 Overview Photo

The 3308440 has a wide variety of peripheral interface connectors. Figure 1-2 is a labeled photo of the peripheral interface connectors on the 3308440.

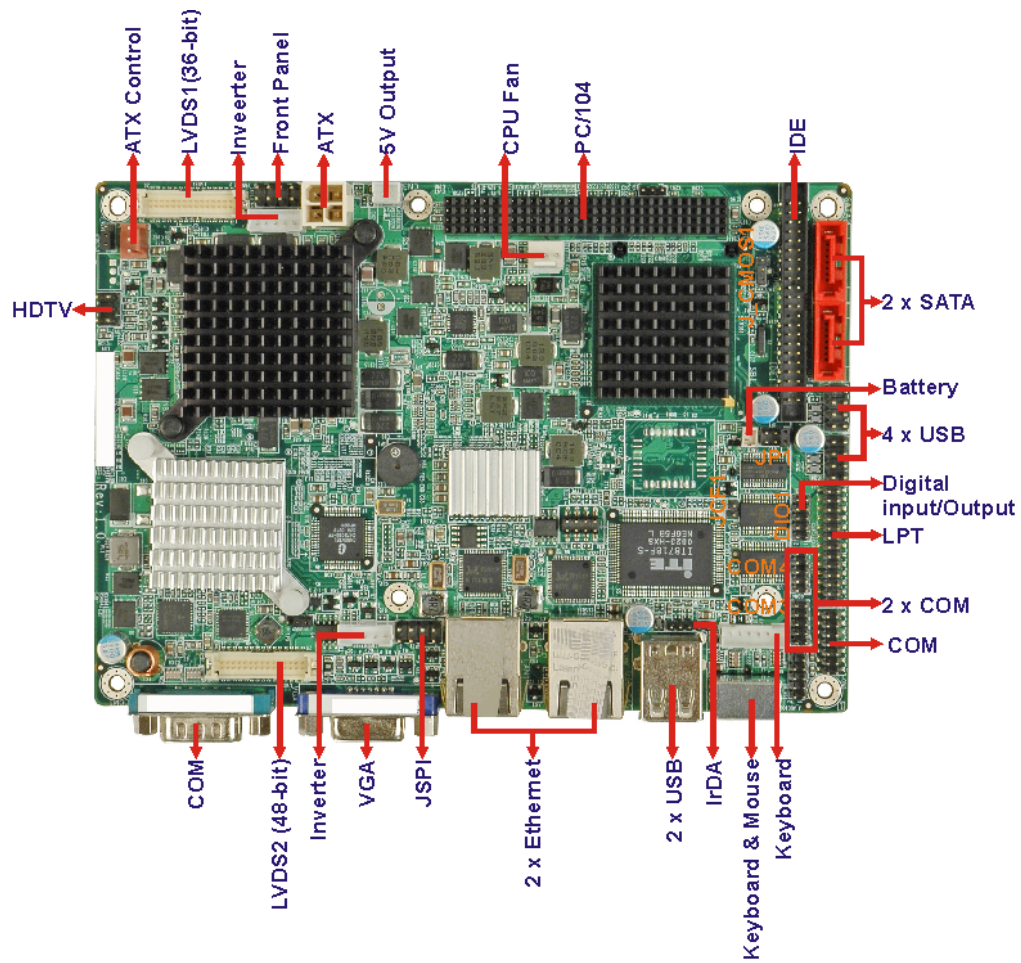

Figure 1-2: 3308440 Overview [Front View]

Figure 1-3 shows the rear side of the 3308440.

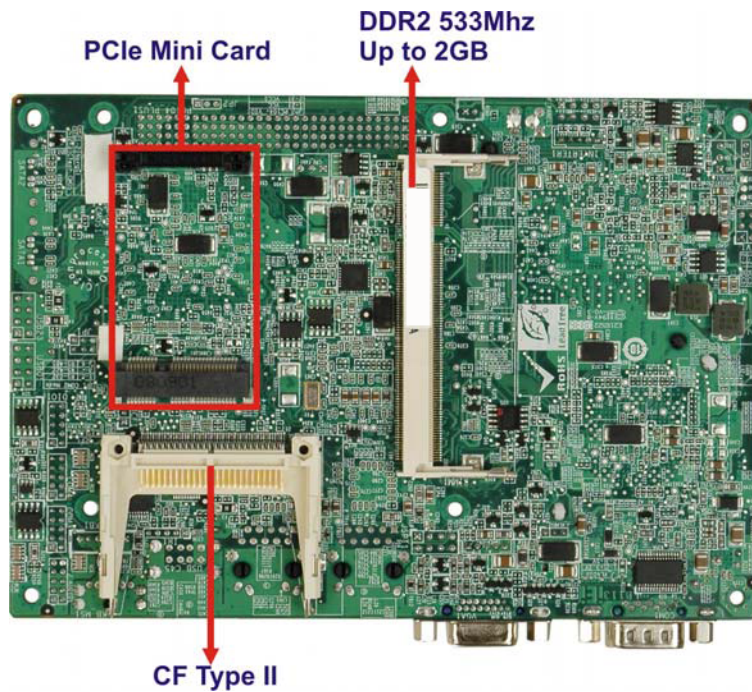

Figure 1-3: 3308440 Overview [Solder Side]

1.2.2 3308440 SBC Peripheral Connectors and Jumpers

The 3308440 has the following connectors on-board:

- 1 x +12V power source connector
- 1 x 5V power connector
- 1 x Audio connector
- 1 x ATX power control connector
- 2 x Backlight inverter connectors
- 1 x CompactFlash® socket
- 1 x Digital input/output (DIO) connector
- 1 x Fan connector
- 1 x Front panel connector
- 1 x IDE disk drive connectors (44-pin)
- 1 x Infrared interface (IrDA) connector
- 1 x Keyboard connector
- 2 x LVDS connectors
- 1 x Parallel port connector

- 1 x PCI-104 slot
- 1 x PCIe Mini Card slot
- 2 x Serial ATA (SATA) drive connectors
- 2 x RS-232 serial port connectors
- 1 x RS-232/422/485 serial port connector
- 1 x TV Out connector
- 2 x USB 2.0 connectors (supports four USB 2.0 devices)

The 3308440 SBC has the following external peripheral interface connectors on the board rear panel.

- 2 x Ethernet connectors
- 1 x PS/2 connector
- 1 x Serial port connector
- 2 x USB connectors
- 1 x VGA connector

The 3308440 SBC has the following on-board jumpers:

- AT Power Mode Setting
- Clear CMOS
- CF card setup
- LVDS1 Voltage Selection
- LVDS1 Panel Resolution Selection
- LVDS2 Voltage Selection
- COM2 Port Mode setting
- PC104+ VIO Selector

1.2.3 Technical Specifications

3308440 SBC technical specifications are listed in **Table 1-1**. See **Chapter 2** for details.

Specification	
Form Factor	EPIC
System CPU	45 nm 1.6 GHz Intel® Atom™ N270

Front Side Bus (FSB)	533 MHz
System Chipset	Northbridge: Intel® 945GSE Southbridge: Intel® ICH7-M
Memory	One 200-pin SO-DIMM socket supports one 533 MHz 2.0 GB (max.) DDR2 SDRAM SO-DIMM
CompactFlash®	One CompactFlash® Type II socket
Super I/O	ITE IT8718
Display	Intel® Generation 3.5 integrated GFX core (133 MHz) HDTV with 1080i maximum resolution supported Dual LVDS support 18-bit dual channel LVDS integrated in Intel® 945GSE 3308440B: 18/24-bit dual-channel supported with CH7308
BIOS	AMI BIOS label
Audio	5.1 channel audio kit with Realtek ALC655 AC'97 codec 7.1 channel HD audio kit with Realtek ALC883 codec supports dual audio streams
LAN	Two Realtek RTL8111CP GbE controllers
COM	Three RS-232 serial ports One RS-232/422/485 serial port
USB2.0	Six USB 2.0 devices supported: <ul style="list-style-type: none"> ■ Four by onboard pin-headers ■ Two by external connectors
Hard Drives	One 44-pin IDE connector connects to two Ultra ATA33/66/100 devices

SATA	Two 1.5 Gbps SATA drives supported
Keyboard/mouse	One external PS/2 connector
Parallel Port	One 26-pin parallel port connector
Expansion	One PCI-104 expansion slot (PCI bus) One PCIe mini card (PCIe bus)
Digital I/O	One 8-bit digital input/output connector; 4-bit input/4-bit output through the ITE IT8718 super I/O
Watchdog Timer	Software programmable 1-255 sec. through the ITE IT8718 super I/O
Infrared	One infrared connector through the ITE IT8718 super I/O. Supports: <ul style="list-style-type: none"> ■ Serial Infrared (SIR) ■ Amplitude Shift Keyed IR (ASKIR)
Power Supply	ATX and AT power supported
Power Consumption	12V @ 1.53 A (1.6 GHz Intel® Atom™ one 2.0 GB DDR2 SO-DIMM)
Temperature	0°C – 60°C (32°F - 140°F)
Humidity (operating)	5%~95% non-condensing
Dimensions (LxW)	115mm x 165mm
Weight (GW/NW)	700g/350g

Table 1-1: Technical Specifications

Chapter

2

Detailed Specifications

2.1 Dimensions

2.1.1 Board Dimensions

The dimensions of the board are listed below:

- **Length:** 165 mm
- **Width:** 115 mm

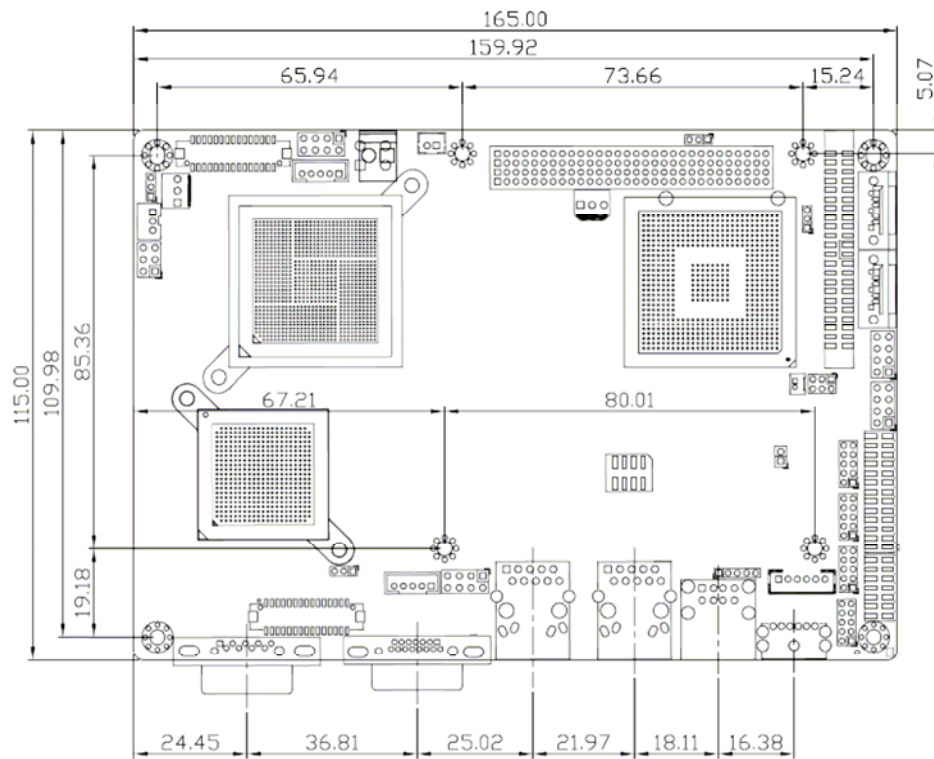

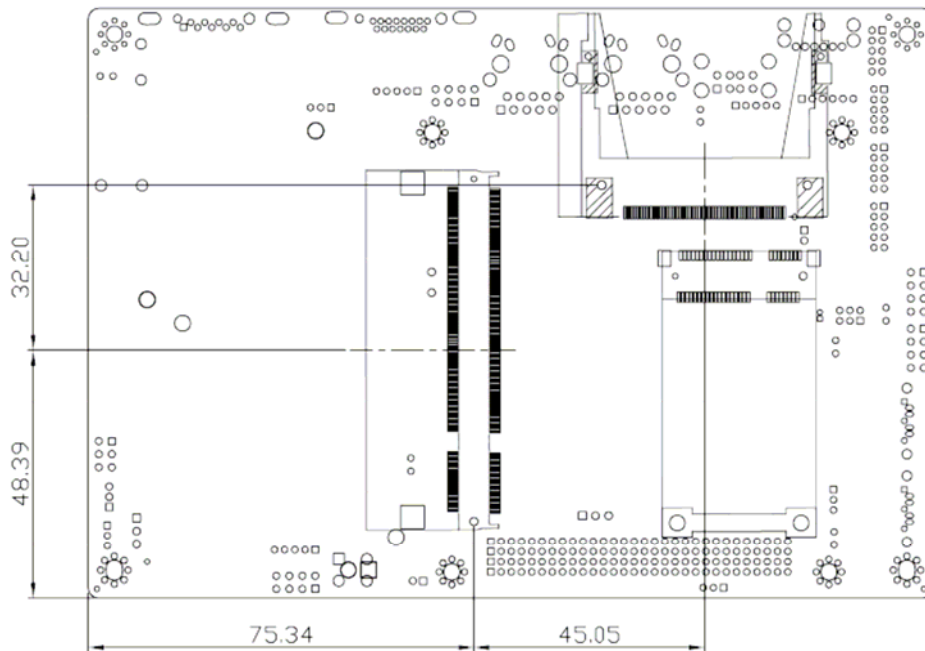

Figure 2-1: 3308440 Dimensions (mm)

2.1.2 External Interface Panel Dimensions

External peripheral interface connector panel dimensions are shown in **Figure 2-2**.

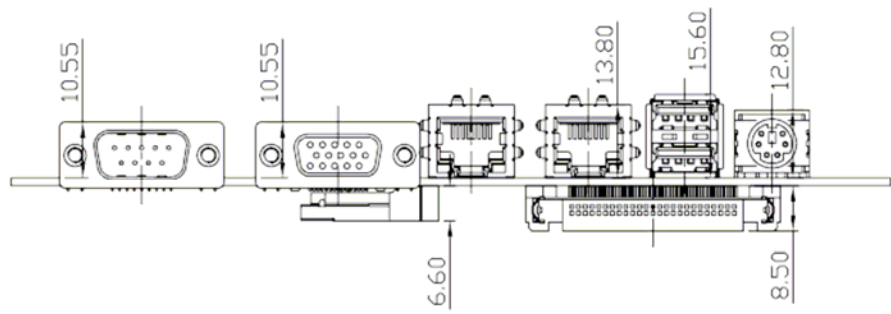

Figure 2-2: External Interface Panel Dimensions (mm)

2.2 Data Flow

Figure 2-3 shows the data flow between the two on-board chipsets and other components installed on the motherboard and described in the following sections of this chapter.

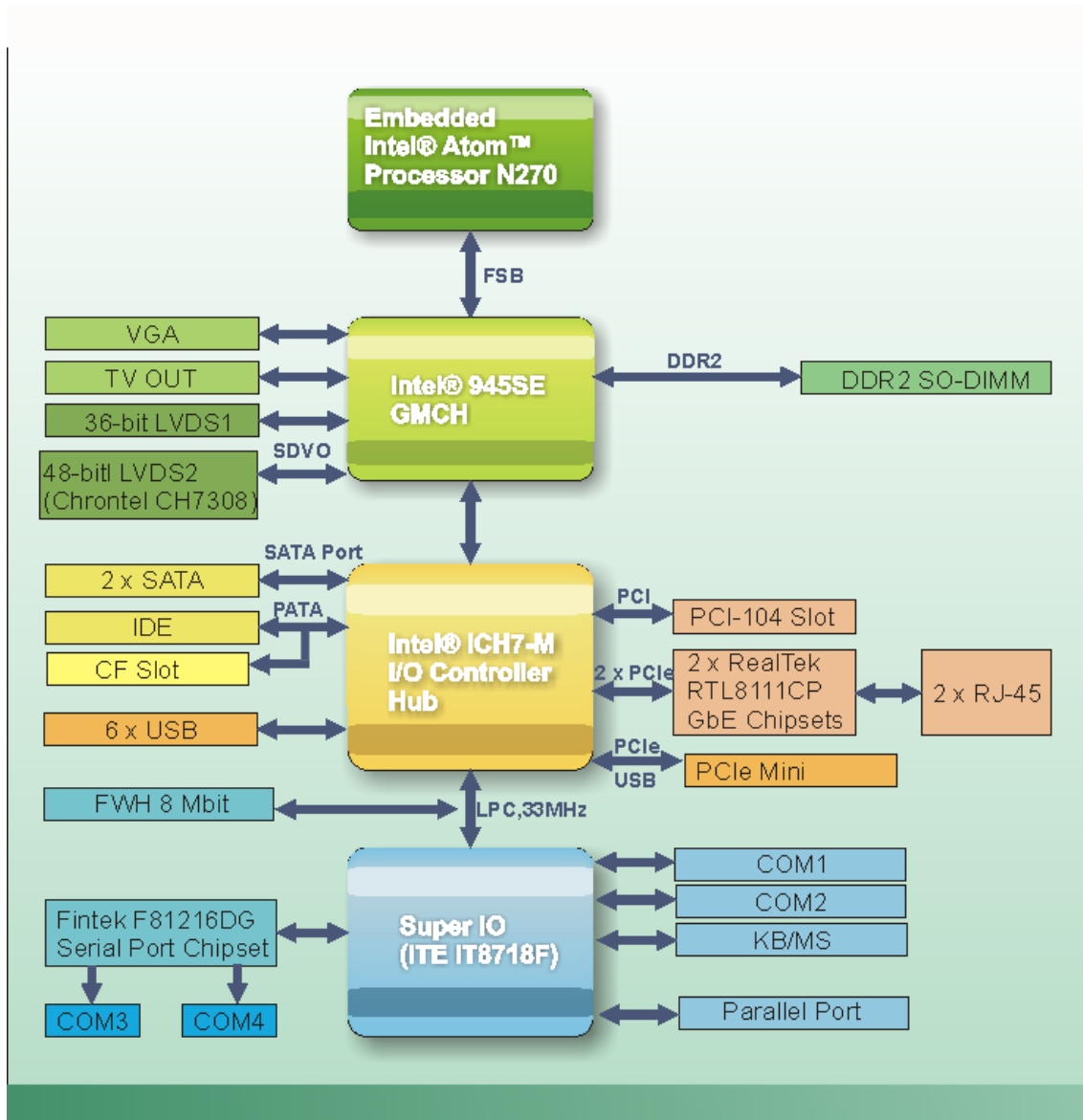

Figure 2-3: Data Flow Block Diagram

2.3 Embedded 3308440 Processor

2.3.1 Overview

The 3308440 comes with an embedded 45 nm 1.60 GHz Intel® Atom™ processor N270. The processor supports a 533 MHz FSB and has a 1.6 GHz 512 KB L2 cache. The low power processor has a maximum power of 2.5 W. The processor is covered with a heat sink and is shown in Figure 2-4 below.

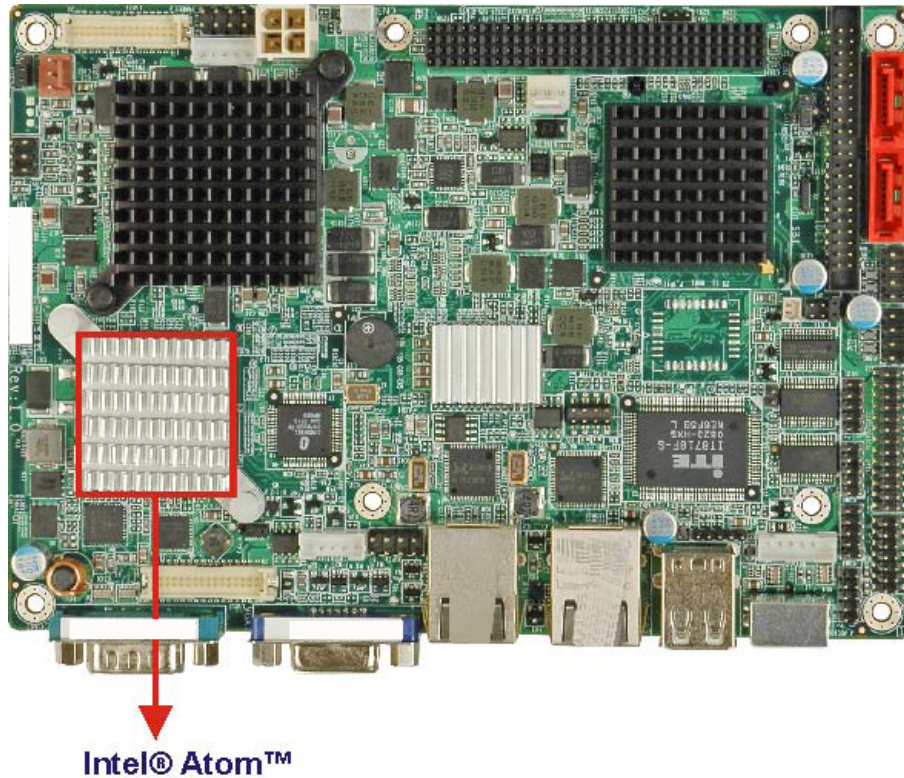

Figure 2-4: Embedded Processor Covered by Heat Sink

2.3.2 Features

Some of the features of the Intel® Atom™ processor N270 are listed below

- On-die, primary 32-kB instructions cache and 24-kB write-back data cache
- 533-MHz source-synchronous front side bus (FSB)
- 2-Threads support
- On-die 512-kB, 8-way L2 cache
- Support for IA 32-bit architecture
- Intel® Streaming SIMD Extensions-2 and -3 (Intel® SSE2 and Intel® SSE3) support and Supplemental Streaming SIMD Extension 3 (SSSE3) support
- Micro-FCBGA8 packaging technologies
- Thermal management support via Intel® Thermal Monitor 1 and Intel Thermal Monitor 2
- FSB Lane Reversal for flexible routing
- Supports C0/C1(e)/C2(e)/C4(e)

- L2 Dynamic Cache Sizing
- Advanced power management features including Enhanced Intel SpeedStep® Technology
- Execute Disable Bit support for enhanced security

2.3.3 Front Side Bus (FSB)

The Intel® Atom™ processor on the 3308440 is interfaced to the Intel 945GSE Northbridge through a 533 MHz front side bus (FSB). The FSB is shown in **Figure 2-5** below.

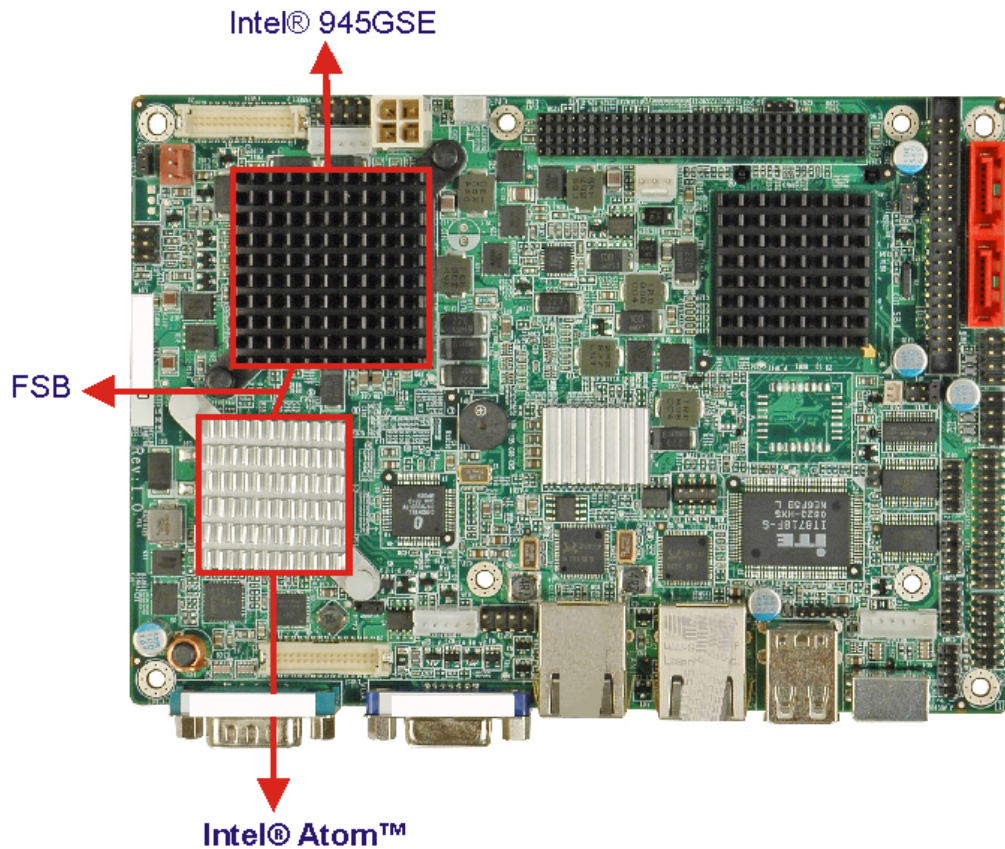

Figure 2-5: Front Side Bus

2.4 Intel 945GSE Northbridge Chipset

2.4.1 Intel® 945GSE Overview

The Intel 945GSE Graphics and Memory Controller Hub (GMCH) supports the embedded Intel® Atom™ N270 processor. The Intel 945GSE is interfaced to the processor through a 533 MHz FSB.

2.4.2 Intel® 945GSE DDR2 Controller

There is one 200-pin DDR2 SO-DIMM socket on the 3308440 . The socket supports DDR2 SO-DIMM with the following specifications:

- Maximum Memory supported 2 GB (1 GB per rank)
- Support for DDR2 at 400 MHz and 533 MHz
- No support for Dual-Channel Interleaved mode of operation
- Enhanced Addressing support (Swap only)

The SO-DIMM socket is shown in Figure 2-6 below.

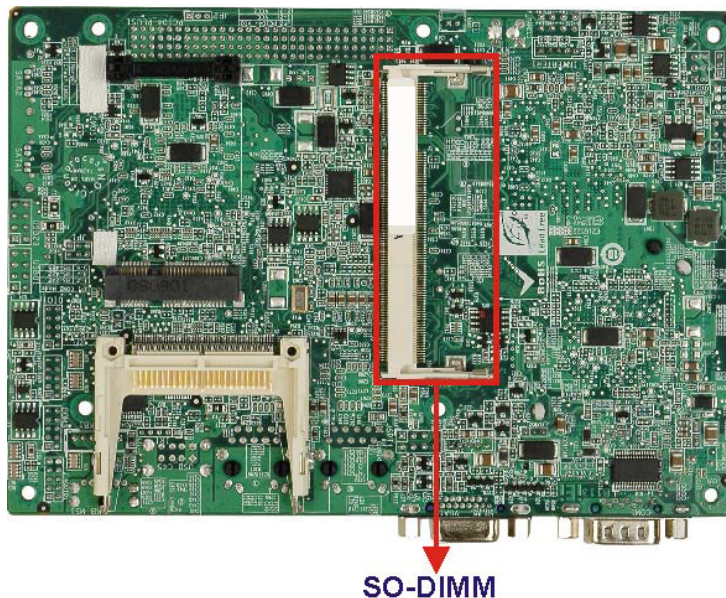

Figure 2-6: DDR2 SO-DIMM Socket

2.4.3 Intel® 945GSE Graphics

The Intel® 945GSE supports CRT, LVDS, TV-OUT and SDVO. The SDVO bus is interfaced through a Chronitel SDVO-to-LVDS transmitter to a second LVDS connector.

The internal graphics engine has the following features:

- Intel® Gen 3.5 Integrated Graphics Engine
- 250-MHz core render clock and 200 MHz core display clock at 1.05-V core voltage
- Supports TV-Out, LVDS, CRT and SDVO
- Dynamic Video Memory Technology (DVMT 3.0)
- Intel® Display Power Saving Technology 2.0 (Intel® DPST 2.0)
- Intel® Smart 2D Display Technology (Intel® S2DDT)
- Intel® Automatic Display Brightness
- Video Capture via x1 concurrent PCIe port
- Concurrent operation of x1 PCIe and SDVO
- 4x pixel rate HWMC
- Microsoft DirectX® 9.1 operating system
- Intermediate Z in Classic Rendering
- Internal Graphics Display Device States: D0, D1, D3
- Graphics Display Adapter States: D0, D3.

2.4.3.1 Analog CRT Graphics Mode

The analog CRT bus is interfaced to an external DB-15 interface connector. The connector is shown below.

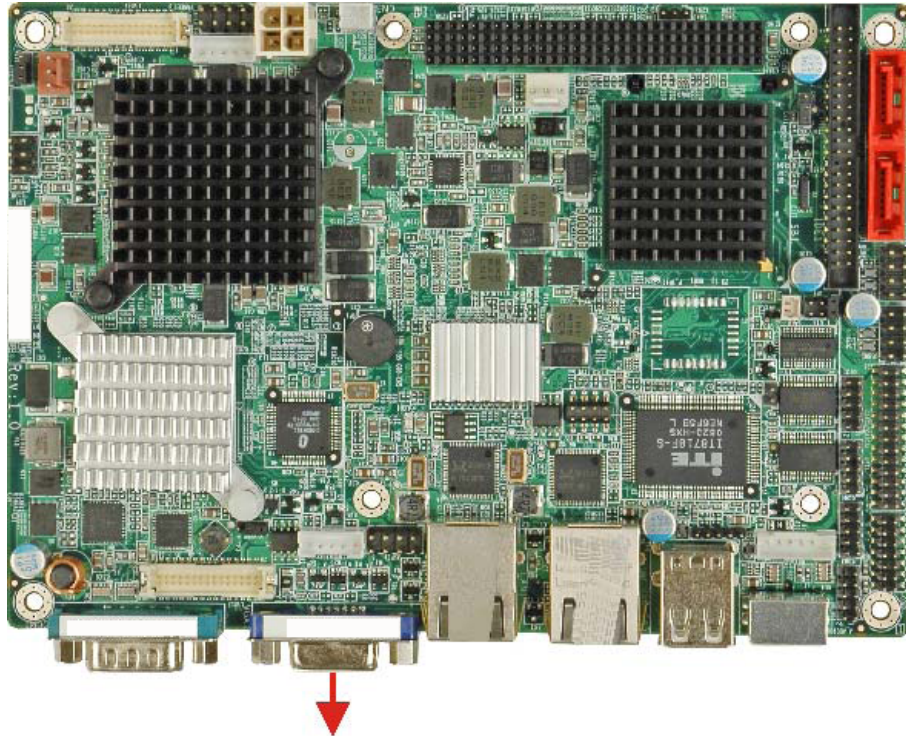

VGA DB-15 Connector

Figure 2-7: VGA Connector

Some of the features of the CRT include:

- Integrated 400-MHz RAMDAC
- Analog Monitor Support up to QXGA
- Support for CRT Hot Plug

2.4.3.2 LVDS Interface

The LVDS interface is connected directly to one of the LVDS connectors on the board.

Some of the features of the LVDS interface include:

- Panel support up to UXGA (1600 x 1200)
- 25-MHz to 112-MHz single-/dual-channel; @18 bpp
 - TFT panel type supported
- Pixel Dithering for 18-bit TFT panel to emulate 24-bpp true color displays
- Panel Fitting, Panning, and Center Mode Supported
- CPIS 1.5 compliant

-
- Spread spectrum clocking supported
 - Panel Power Sequencing support
 - Integrated PWM interface for LCD backlight inverter control

2.4.3.3 TV Out Interface

The TV Out interface has the following features.

- Three integrated 10-bit DACS
- Overscaling
- NTSC/PAL
- Component, S-Video and Composite Output interfaces
- HDTV support
 - 480p/720p/1080i/1080p

2.4.3.4 Chrontel CH7308B SDVO / LVDS Support

A 30-pin LVDS crimp connector is connected to the Chrontel CH7308B chipset, which is connected to the Intel® 945GSE through one of the SDVO ports. Some of the features of the transmitter include.

- 18/24-bit outputs
- Up to 140 megapixels per second

The Chrontel SDVO-to-LVDS transmitter is shown in Figure 2-8.

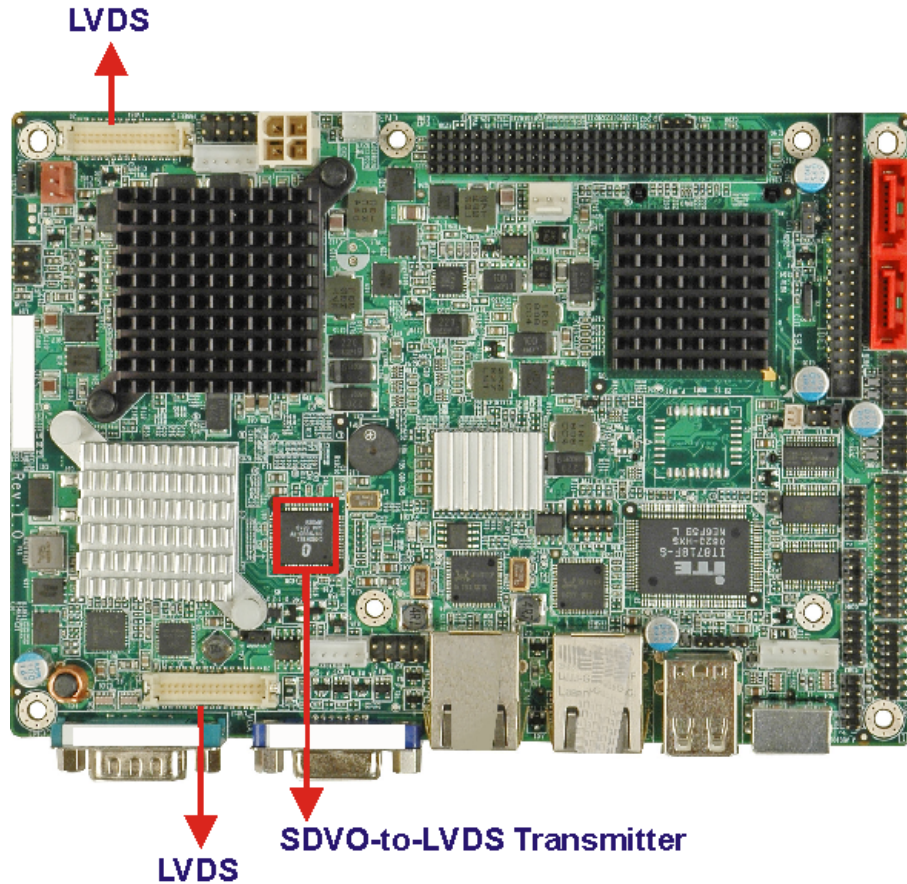

Figure 2-8: Chrontel SDVO-to-LVDS DAC Chipset

2.5 Intel® ICH7-M Southbridge Chipset

2.5.1 Intel® ICH7-M Overview

The Intel® ICH7-M southbridge chipset is connected to the Intel® 945GSE northbridge GMCH through the chip-to-chip Direct Media Interface (DMI). Some of the features of the Intel® ICH7-M are listed below.

- Complies with PCI Express Base Specification, Revision 1.0a
- Complies with PCI Local Bus Specification, Revision 2.3 and supports 33MHz PCI operations
- Supports ACPI Power Management Logic
- Contains:
 - Enhanced DMA controller

-
- Interrupt controller
 - Timer functions
 - Integrated SATA host controller with DMA operations interfaced to four SATA connectors on the 3308440
 - Integrated IDE controller supports Ultra ATA 100/66/33
 - Supports the four USB 2.0 devices on the 3308440 with four UHCI controllers and one EHCI controller
 - Complies with System Management Bus (SMBus) Specification, Version 2.0
 - Supports Audio Codec '97 (AC'97) Revision 2.3
 - Supports Intel® High Definition Audio
 - Contains Low Pin Count (LPC) interface
 - Supports Firmware Hub (FWH) interface
 - Serial peripheral interface support

2.5.2 Intel® ICH7-M Audio Controllers

The Intel® ICH7-M has the following to audio controllers.

- AC'97 controller
- HD Audio controller

The controllers share the same pins and only one can be activated at a time. The controllers are interfaced to the 3308440 audio connector which is in turn connected to an option audio kit with either an AC'97 codec or an HD Audio codec.

2.5.2.1 Intel® ICH7-M Audio Codec '97 Controller

The Audio Codec '97 (AC'97) controller integrated into the ICH7-M complies with AC'97 Component Specification, Version 2.3. The AC'97 controller is connected to the onboard audio connector. The audio connector is connected to an optional 5.1 channel audio kit with an embedded AC'97 audio codec. The AC'97 controller supports up to six PCM audio output channels. Complete surround sound requires six-channel audio consisting of:

- Front left
- Front right
- Back left

- Back right
- Center
- Subwoofer

2.5.2.2 Intel® ICH7-M High Definition (HD) Audio Controller

The Intel® HD Audio controller on the Intel® ICH7-M shares pins with the AC'97 controller. Only one controller can be used at a time. Intel® HD Audio controller is interfaced through the Intel® High Definition Audio serial link to the audio connector which is in turn connected to an optional 7.1 channel audio kit with an HD audio codec.

2.5.3 Intel® ICH7-M IDE Interface

The integrated IDE interface on the ICH7-M southbridge supports two IDE hard disks and ATAPI devices. The IDE connector is shown in Figure 2-9 below.

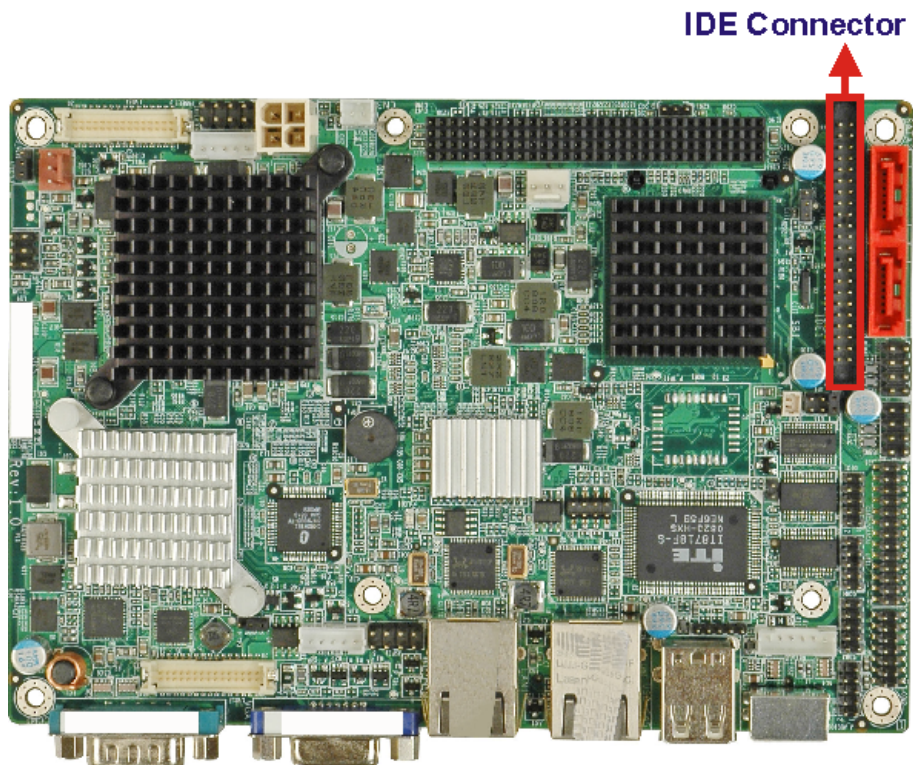

Figure 2-9: IDE Connector

PIO IDE transfers up to 16MB/s and Ultra ATA transfers of 100MB/s. The integrated IDE interface is able to support the following IDE HDDs:

- **Ultra ATA/100**, with data transfer rates up to 100MB/s
- **Ultra ATA/66**, with data transfer rates up to 66MB/s

Specification	Ultra ATA/100	Ultra ATA/66
IDE devices	2	2
PIO Mode	0 – 4	0 – 4
PIO Max Transfer Rate	16.6 MB/s	16.6 MB/s
DMA/UDMA designation	UDMA 3 - 4	UDMA 3 – 4
DMA/UDMA Max Transfer	100MB/s	66MB/s
Controller Interface	5V	5V

Table 2-1: Supported HDD Specifications

2.5.4 Intel® ICH7-M Low Pin Count (LPC) Interface

The ICH7-M LPC interface complies with the LPC 1.1 specifications. The LPC bus from the ICH7-M is connected to the following components:

- BIOS chipset
- Super I/O chipset

2.5.5 Intel® ICH7-M PCI Interface

The PCI interface on the ICH7-M is compliant with the PCI Revision 2.3 implementation. Some of the features of the PCI interface are listed below.

- PCI Revision 2.3 compliant
- 33MHz
- 5V tolerant PCI signals (except PME#)
- Integrated PCI arbiter supports up to seven PCI bus masters

The PCI bus is connected to a PCI-104 connector as shown in Figure 2-10.

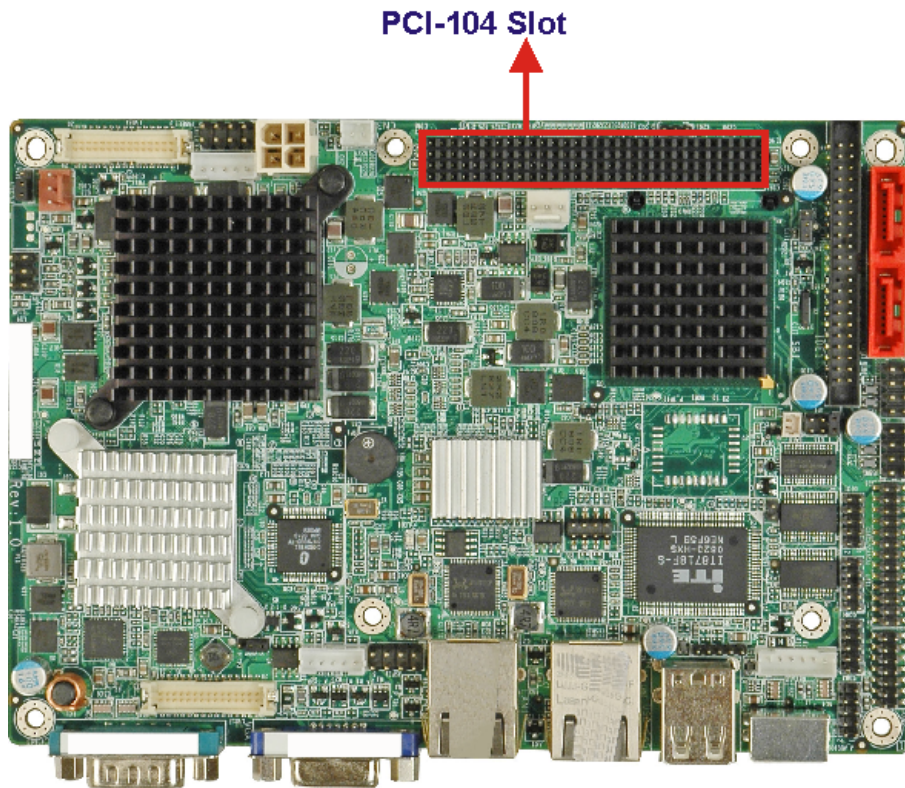

Figure 2-10: PCI-104 Connector

2.5.6 Intel® ICH7-M PCIe Bus

The Intel® ICH7-M southbridge chipset has four PCIe lanes. Two of the four PCIe lanes are interfaced to PCIe GbE controller. A third PCIe lane is interfaced to a PCIe mini socket.

2.5.6.1 PCIe GbE Ethernet

Two PCIe lanes are connected to two Realtek RTL8111C PCIe GbE controllers shown in Figure 2-11 below.

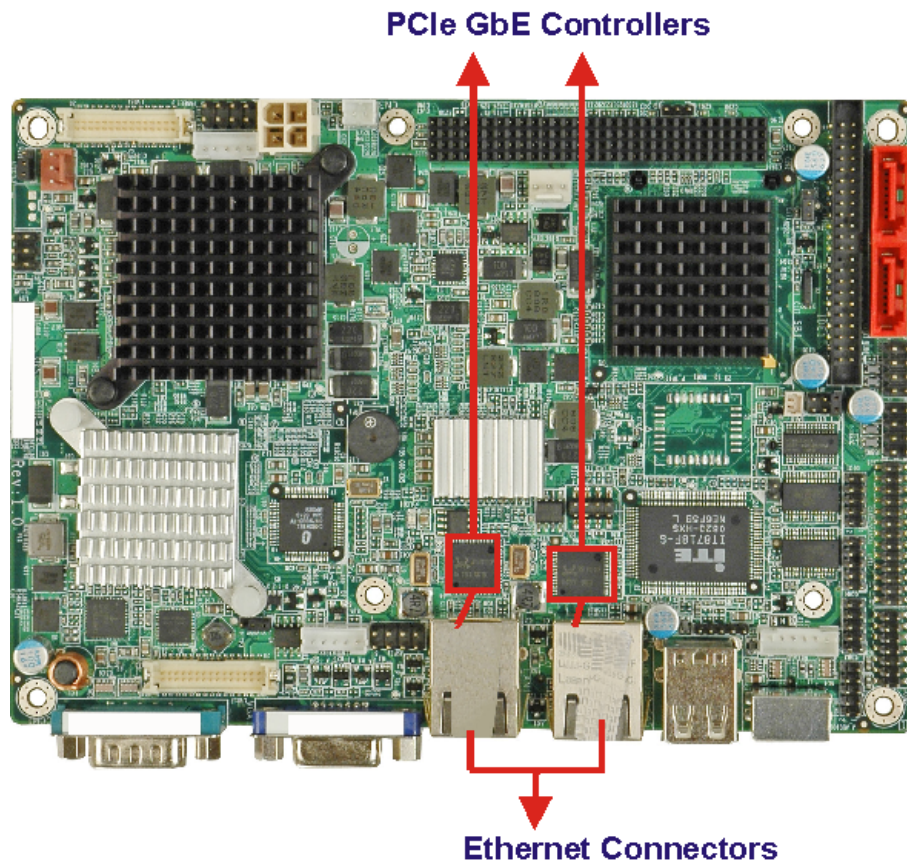

Figure 2-11: Realtek PCI GbE Controllers

The Realtek RTL8111C PCIe GbE controllers combine a triple-speed IEEE 802.3 compliant Media Access Controller (MAC) with a triple-speed Ethernet transceiver, 32-bit PCIe bus controller, and embedded memory. With state-of-the-art DSP technology and mixed-mode signal technology, they offer high-speed transmission over CAT 5 UTP cable or CAT 3 UTP (10Mbps only) cable. Functions such as Crossover Detection & Auto-Correction, polarity correction, adaptive equalization, cross-talk cancellation, echo cancellation, timing recovery, and error correction are implemented to provide robust transmission and reception capability at high speeds.

Some of the features of the Realtek RTL8111CP PCIe GbE controllers are listed below.

- Integrated 10/100/1000 transceiver
- Auto-Negotiation with Next Page capability

-
- Supports PCI Express™ 1.1
 - Supports pair swap/polarity/skew correction
 - Crossover Detection & Auto-Correction
 - Wake-on-LAN and remote wake-up support
 - Microsoft® NDIS5, NDIS6 Checksum Offload (IPv4, IPv6, TCP, UDP) and Segmentation Task-offload (Large send and Giant send) support
 - Supports Full Duplex flow control (IEEE 802.3x)
 - Fully compliant with IEEE 802.3, IEEE 802.3u, IEEE 802.3ab
 - Supports IEEE 802.1P Layer 2 Priority Encoding
 - Supports IEEE 802.1Q VLAN tagging
 - Serial EEPROM
 - Transmit/Receive on-chip buffer support
 - Supports power down/link down power saving
 - Supports PCI MSI (Message Signaled Interrupt) and MSI-X
 - Supports Receive-Side Scaling (RSS)

2.5.6.2 PCIe Mini Expansion Slot

One PCIe x1 port in combination with a USB port on the ICH7-M is interfaced directly to a PCIe mini expansion slot. This enables the addition of PCIe mini expansion devices. The PCIe mini slot is shown in Figure 2-12.

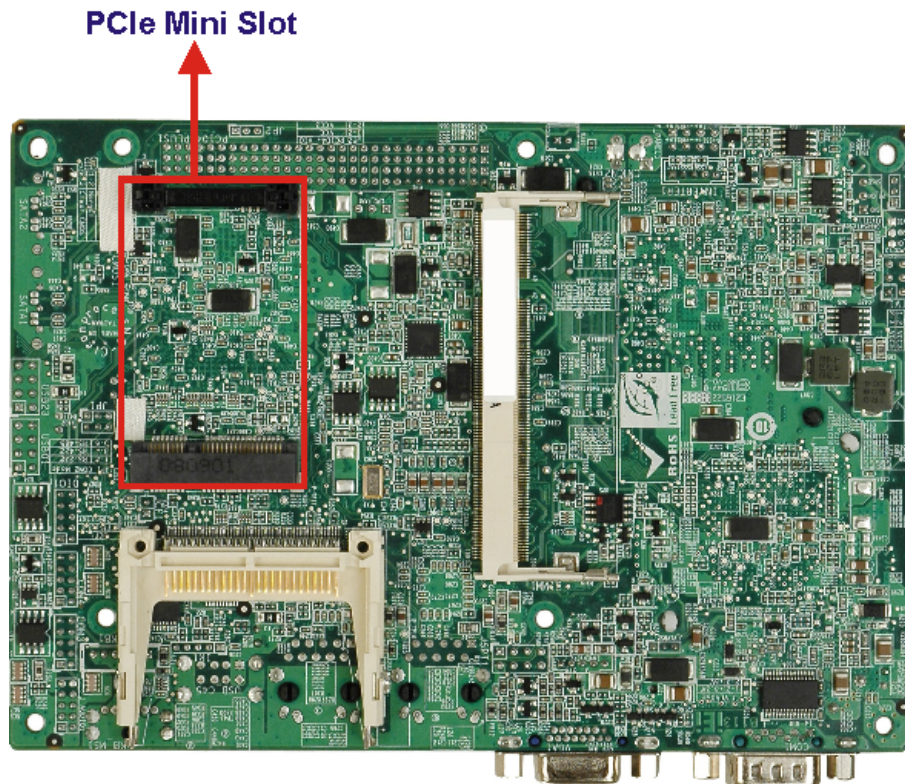

Figure 2-12: PCIe Mini Slot

2.5.7 Intel® ICH7-M Real Time Clock

256 bytes of battery backed RAM is provided by the Motorola MC146818A real time clock (RTC) integrated into the ICH7-M. The RTC operates on a 3V battery and 32.768KHz crystal. The RTC keeps track of the time and stores system data even when the system is turned off.

2.5.8 Intel® ICH7-M SATA Controller

The integrated SATA controller on the ICH7-M southbridge supports up to four SATA drives with independent DMA operations. Two SATA controllers are connected to two SATA connectors on the 3308440 . The SATA connectors are shown in Figure 2-13.

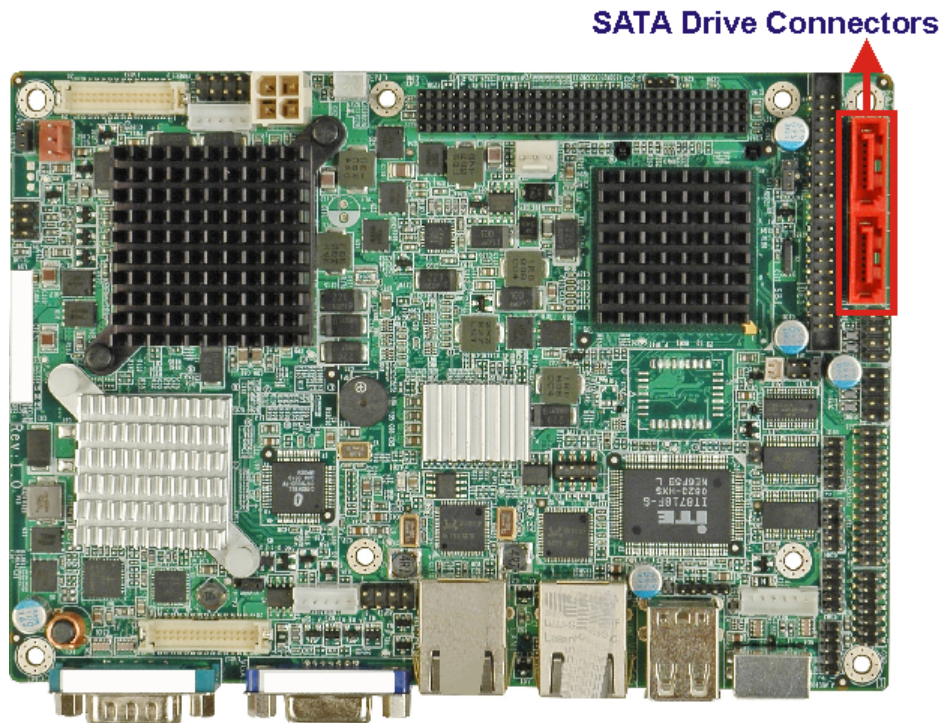

Figure 2-13: SATA Connectors

SATA controller specifications are listed below.

- Supports four SATA drives
- Supports 3Gb/s data transfer speeds
- Supports Serial ATA Specification, Revision 1.0a

2.5.9 Intel® ICH7-M USB Controller

Up to six high-speed, full-speed or low-speed USB devices are supported by the ICH7-M on the 3308440. High-speed USB 2.0, with data transfers of up to 480MB/s, is enabled with the ICH7-M integrated Enhanced Host Controller Interface (EHCI) compliant host controller. USB full-speed and low-speed signaling is supported by the ICH7-M integrated Universal Host Controller Interface (UHCI) controllers.

The six USB ports implemented on the 3308440 SBC are connected to two internal connectors and one external connector. See **Figure 2-14**.

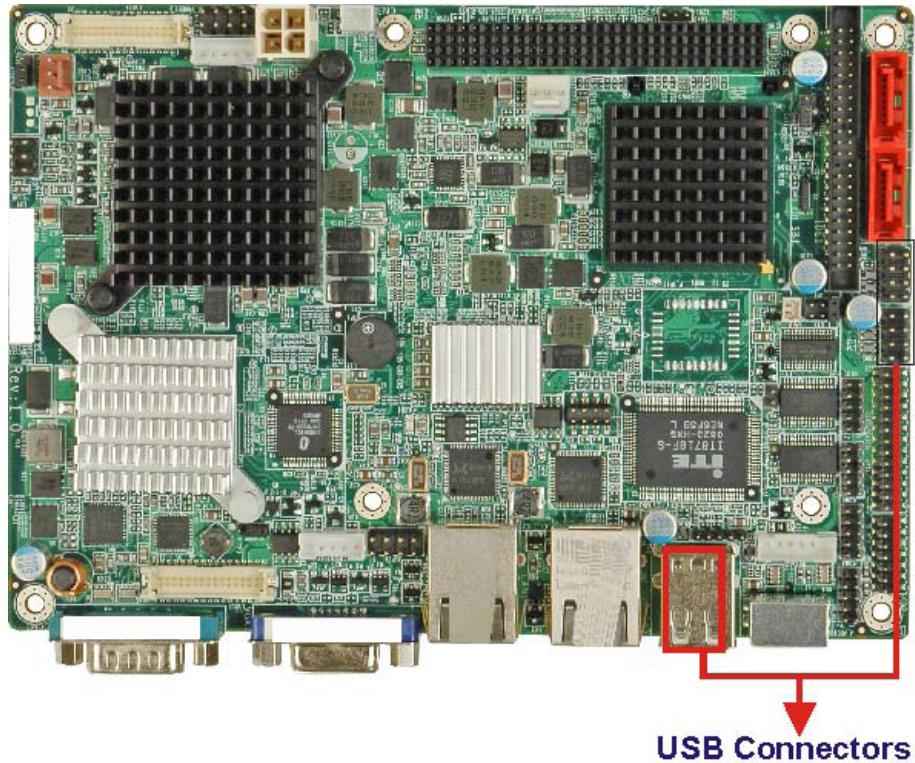

Figure 2-14: Onboard USB Implementation

2.6 LPC Bus Components

2.6.1 LPC Bus Overview

The LPC bus is connected to components listed below:

- BIOS chipset
- Super I/O chipset
- LPC Serial Port Chipset

2.6.2 BIOS Chipset

The BIOS chipset has a licensed copy of AMI BIOS installed on the chipset. Some of the BIOS features are listed below:

- AMI Flash BIOS
- SMIBIOS (DMI) compliant
- Console redirection function support

- PXE (Pre-boot Execution Environment) support
- USB booting support

2.6.3 iTE IT8718F Super I/O chipset

The iTE IT8718F Super I/O chipset is connected to the ICH7-M southbridge through the LPC bus.

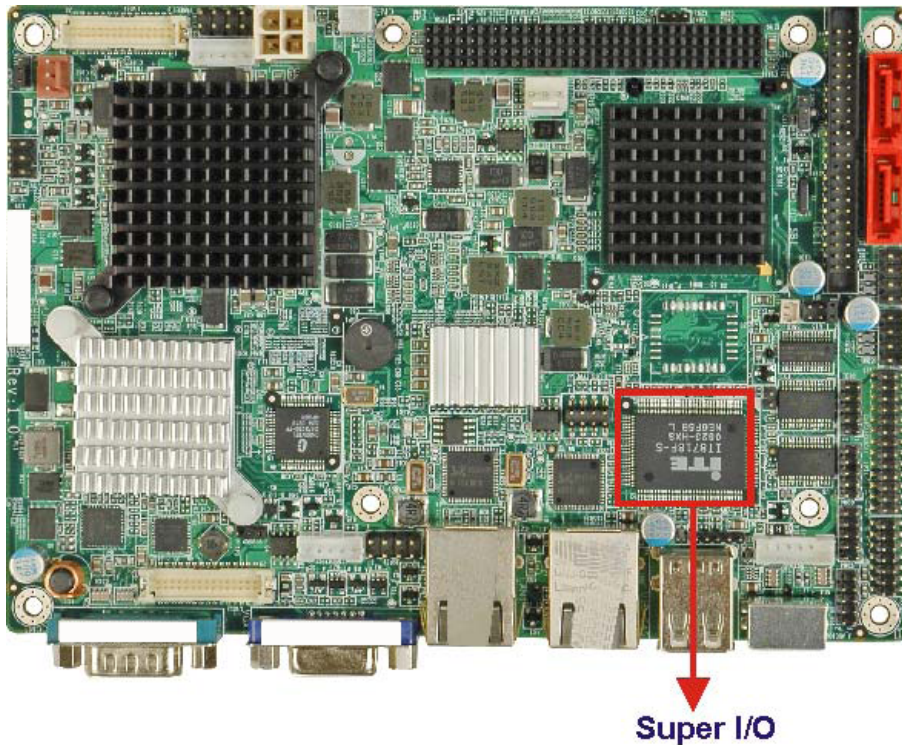

Figure 2-15: Super I/O

The iTE IT8718F is an LPC interface-based Super I/O device that comes with Environment Controller integration. Some of the features of the iTE IT8718F chipset are listed below:

- ACPI and LANdesk Compliant
- Enhanced Hardware Monitor
- Fan Speed Controller
- Two 16C550 UARTs for serial port control
- One IEEE 1284 Parallel Port

-
- Keyboard Controller
 - Watchdog Timer

Some of the Super I/O features are described in more detail below:

2.6.3.1 Super I/O LPC Interface

The LPC interface on the Super I/O complies with the Intel® Low Pin Count Specification Rev. 1.0. The LPC interface supports both LDRQ# and SERIRQ protocols as well as PCI PME# interfaces.

2.6.3.2 Super I/O 16C550 UARTs

The onboard Super I/O has two integrated 16C550 UARTs that can support the following:

- Two standard serial ports (COM1 and COM2)
- IrDa 1.0 and ASKIR protocols

Another chipset connected to the LPC bus provided connectivity to another two serial port connectors (COM3 and COM4).

2.6.3.3 Super I/O Digital Input/Output

The input mode supports switch debouncing or programmable external IRQ routing. The output mode supports two sets of programmable LED blinking periods.

2.6.3.4 Super I/O Enhanced Hardware Monitor

The Super I/O Enhanced Hardware Monitor monitors three thermal inputs, VBAT internally, and eight voltage monitor inputs. These hardware parameters are reported in the BIOS and can be read from the BIOS Hardware Health Configuration menu.

2.6.3.5 Super I/O Fan Speed Controller

The Super I/O fan speed controller enables the system to monitor the speed of the fan. One of the pins on the fan connector is reserved for fan speed detection and interfaced to the fan speed controller on the Super I/O. The fan speed is then reported in the BIOS.

2.6.3.6 Super I/O Keyboard/Mouse Controller

The Super I/O keyboard/mouse controller can execute the 8042 instruction set. Some of the keyboard controller features are listed below:

- The 8042 instruction is compatible with a PS/2 keyboard and PS/2 mouse
- Gate A20 and Keyboard reset output
- Supports multiple keyboard power on events
- Supports mouse double-click and/or mouse move power on events

2.6.3.7 Super I/O Parallel Port

The multi-mode high-performance parallel port supports the bi-directional Standard Parallel Port (SPP), the Enhanced Parallel Port (EPP) and the Extended Capabilities Port (ECP) modes.

2.6.4 Fintek F81216DG LPC Serial Port Chipset

The Fintek F81216DG chipset enables the addition of four additional UART serial ports (COM3 and COM4). UART includes 16-byte send/receive FIFO. The Fintek serial port chipset is interfaced to the Southbridge chipset through the LPC bus. Some of the features of the Fintek chipset are listed below:

- Supports LPC interface
- Totally provides 4 UART (16550 asynchronous) ports
 - 3 x Pure UART
 - 1 x UART+IR
- One Watch dog timer with WDTOUT# signal
- One Frequency input 24/48MHz
- Powered by 3Vcc

2.7 Environmental and Power Specifications

2.7.1 System Monitoring

Two thermal inputs on the 3308440 Super I/O Enhanced Hardware Monitor monitor the following temperatures:

- System temperature
- CPU temperature

Eight voltage inputs on the 3308440 epic Super I/O Enhanced Hardware Monitor monitor the following voltages:

- CPU Core
- +1.05V
- +3.3V
- +12V
- +1.5V
- +1.8V
- +5VSB
- VBAT

The 3308440 Super I/O Enhanced Hardware Monitor also monitors the following fan speeds:

- CPU Fan speed

The values for the above environmental parameters are all recorded in the BIOS Hardware Health Configuration menu.

2.7.2 Operating Temperature and Temperature Control

The maximum and minimum operating temperatures for the 3308440 are listed below.

- Minimum Operating Temperature: 0°C (32°F)
- Maximum Operating Temperature: 60°C (140°F)

A heat sink must be installed on the CPU. Thermal paste must be smeared on the lower side of the heat sink before it is mounted on the CPU. Heat sinks are also mounted on the northbridge and southbridge chipsets to ensure the operating temperature of these chips remain low.

2.7.3 Power Consumption

Table 2-2 shows the power consumption parameters for the 3308440 running with a 1.6 GHz Intel® Atom™ with 2.0 GB DDR2 memory.

Voltage	Current
+12V	1.53A

Table 2-2: Power Consumption

Chapter

3

Unpacking

3.1 Anti-static Precautions



WARNING!

Failure to take ESD precautions during the installation of the 3308440 may result in permanent damage to the 3308440 and severe injury to the user.

Electrostatic discharge (ESD) can cause serious damage to electronic components, including the 3308440 epic. Dry climates are especially susceptible to ESD. It is therefore critical that whenever the 3308440 epic, or any other electrical component is handled, the following anti-static precautions are strictly adhered to.

- **Wear an anti-static wristband:** - Wearing a simple anti-static wristband can help to prevent ESD from damaging the board.
- **Self-grounding:**- Before handling the board touch any grounded conducting material. During the time the board is handled, frequently touch any conducting materials that are connected to the ground.
- **Use an anti-static pad:** When configuring the 3308440, place it on an anti-static pad. This reduces the possibility of ESD damaging the 3308440.
- **Only handle the edges of the PCB:**- When handling the PCB, hold the PCB by the edges.

3.2 Unpacking

3.2.1 Unpacking Precautions





When the 3308440 is unpacked, please do the following:

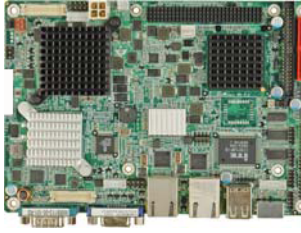

- Follow the anti-static precautions outlined in **Section 3.1**.
- Make sure the packing box is facing upwards so the 3308440 does not fall out of the box.
- Make sure all the components shown in **Section 3.3** are present.

3.3 Unpacking Checklist

3.3.1 Package Contents







The 3308440 is shipped with the following components:





Quantity	Item and Part Number	Image
1	3308440	
2	SATA cable	
1	KB/MS PS/2 Y-cable	
1	AT 12V Cable	
2	1 COM (wo bracket)	

1	Mini jumper pack (2.0mm)	
1	Utility CD	
1	Quick Installation Guide	

3.3.2 Optional Items

The 3308440 is shipped with the following components:

Item and Part Number	Image
Dual USB cable (wo bracket)	
LPT cable (wo bracket)	
RS-232/422/485 cable	
ATX cable	
HDTV output cable	
HDD cable	

IDE-cable	
SATA power cable	
Audio kit_ 5.1 Channel	
Audio kit_ 7.1 Channel	

Chapter

4

Connectors

4.1 Peripheral Interface Connectors

4.1.1 3308440 Layout

Figure 4-1 shows the on-board peripheral connectors, rear panel peripheral connectors and on-board jumpers.

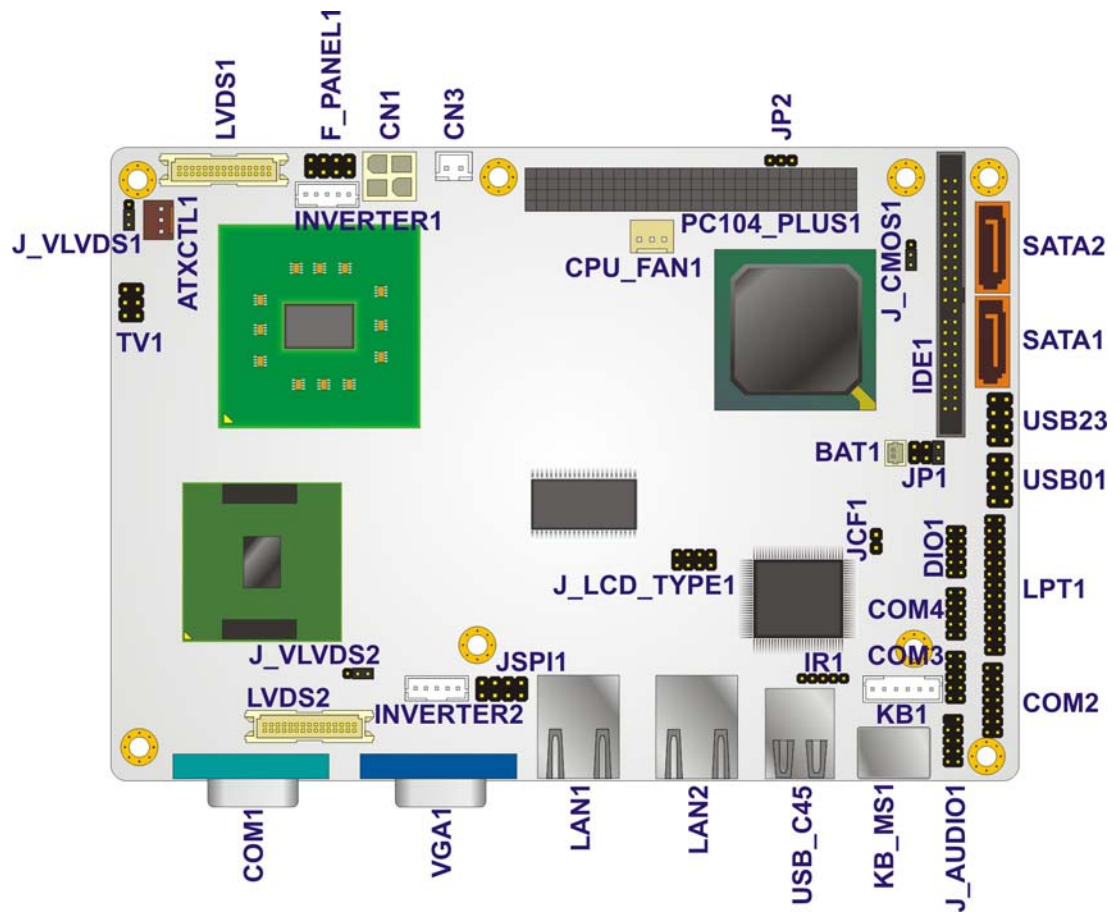

Figure 4-1: Connector and Jumper Locations [Front Side]

Figure 4-2 shows the solder side of the 3308440.

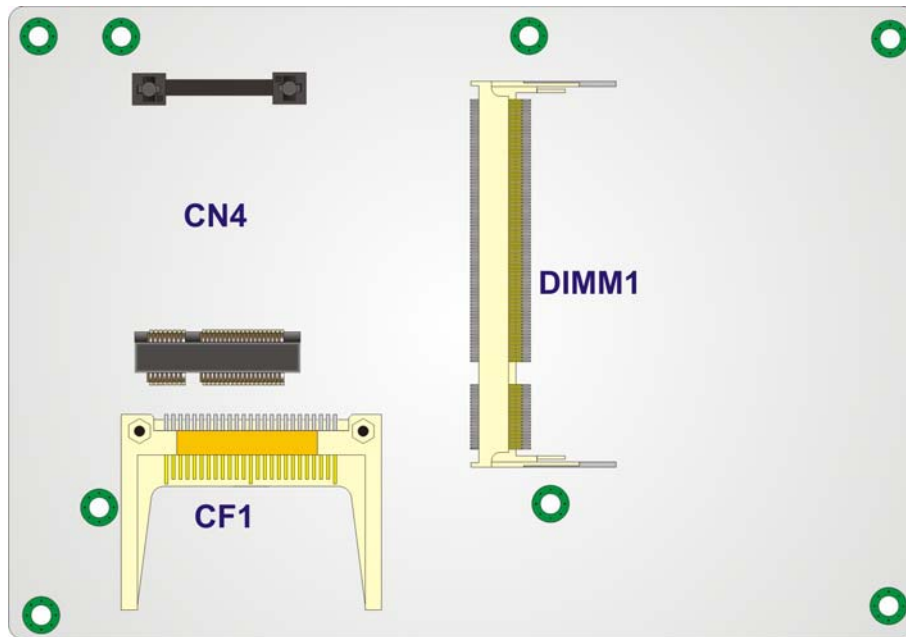

Figure 4-2: Connector and Jumper Locations [Solder Side]

4.2 Peripheral Interface Connectors

Table 4-1 shows a list of the peripheral interface connectors on the 3308440. Detailed descriptions of these connectors can be found below.

Connector	Type	Label
+12V power source connector	4-pin ATX	CN1 and CN2
5V power connector	2-pin wafer	CN3
Audio connector	9-pin header	J_AUDIO1
ATX power control connector	3-pin wafer	ATXCTL1
Backlight inverter connectors	5-pin wafer	INVERTER2
Backlight inverter connectors	5-pin wafer	INVERTER1
CompactFlash® socket	50-pin CF socket	CF1
Digital input/output (DIO) connector	10-pin header	DIO1

Fan connector	3-pin wafer	CPU_FAN1
Front panel connector	8-pin header	F_PANEL1
IDE disk drive connectors (44-pin)	44-pin box header	IDE1
Infrared interface (IrDA) connector	5-pin header	IR1
Keyboard connector	6-pin wafer	KB1
LVDS connector	30-pin crimp	LVDS2
LVDS connector	30-pin crimp	LVDS1
Parallel port connector	26-pin header	LPT1
PCI-104 slot	120-pin socket	PC104_PLUS1
PCIe Mini Card slot	PCIe Mini Slot	CN4
Serial ATA (SATA) drive connectors	7-pin SATA	SATA1
Serial ATA (SATA) drive connectors	7-pin SATA	SATA2
RS-232 serial port connector	10-pin header	COM3
RS-232 serial port connector	10-pin header	COM4
RS-232/422/485 serial port connector	14-pin header	COM2
TV Out connector	6-pin header	TV1
USB 2.0 connector	8-pin header	USB01
USB 2.0 connector	8-pin header	USB23

Table 4-1: Peripheral Interface Connectors

4.2.1 External Interface Panel Connectors

Table 4-2 lists the rear panel connectors on the 3308440. Detailed descriptions of these connectors can be found in **Section 4.4** on **page 67**.

Connector	Type	Label
Ethernet connector	RJ-45	LAN1
Ethernet connector	RJ-45	LAN2
Keyboard/mouse	PS/2	KB_MS1
RS-232 serial port connector	Male DB-9	COM1
Dual USB port	USB port	USB
VGA port connector	15-pin female	VGA1

Table 4-2: Rear Panel Connectors

4.3 Internal Peripheral Connectors

Internal peripheral connectors are found on the motherboard and are only accessible when the motherboard is outside of the chassis. This section has complete descriptions of all the internal, peripheral connectors on the 3308440.

4.3.1 5V Power Connector

- CN Label:** CN3
- CN Type:** 2-pin wafer (1x3)
- CN Location:** See Figure 4-3
- CN Pinouts:** See Table 4-3

The 5V Power Connector provides +5V power output.

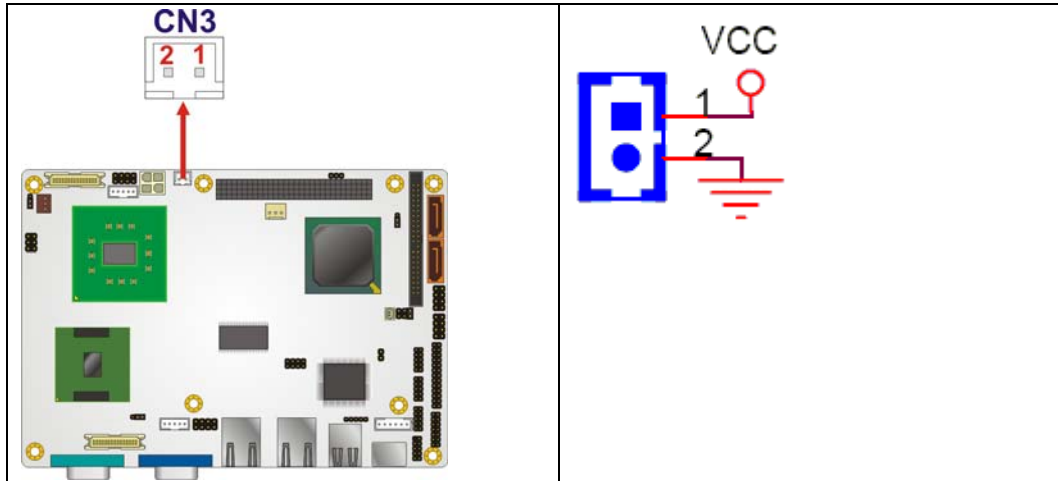

Figure 4-3: 5V Power Connector Pinouts

PIN NO.	DESCRIPTION
1	VCC
2	GND

Table 4-3: 5V Power Connector Pinouts

4.3.2 AT Power Connector

- CN Label:** CN1 & CN2
- CN Type:** 4-pin AT power connector (1x4)
- CN Location:** See **Figure 4-4**
- CN Pinouts:** See **Table 4-4**

The 4-pin +12V AT power connector is connected directly to an AT power supply.

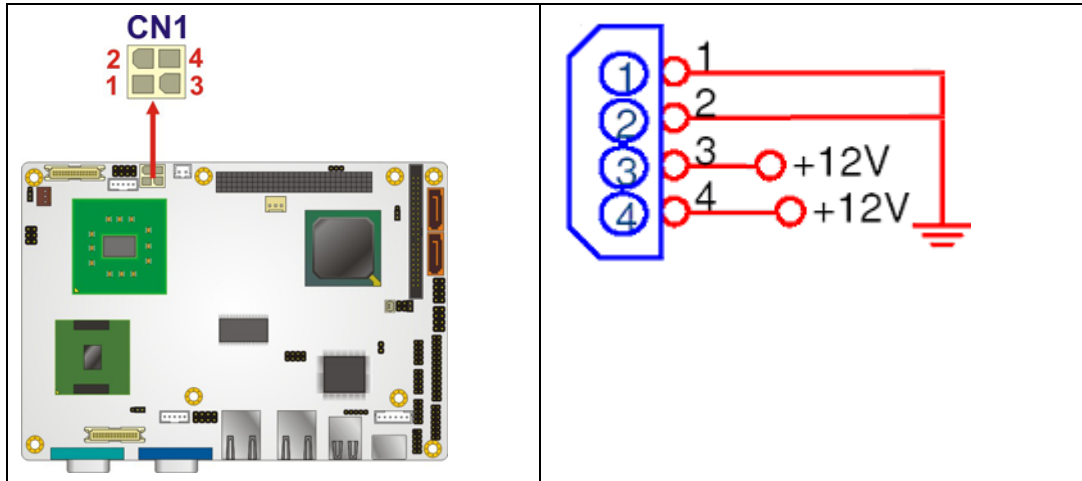

Figure 4-4: AT Power Connector Location

PIN NO.	DESCRIPTION
1	GND
2	GND
3	+ 12V
4	+ 12V

Table 4-4: AT Power Connector Pinouts

4.3.3 ATX Power Supply Enable Connector

- CN Label:** ATXCTL1
- CN Type:** 3-pin wafer (1x3)
- CN Location:** See **Figure 4-5**
- CN Pinouts:** See **Table 4-5**

The ATX power supply enable connector enables the 3308440 to be connected to an ATX power supply. In default mode, the 3308440 can only use an AT power supply. To enable an ATX power supply the AT Power Select jumper must also be configured. Please refer to Chapter 3 for more details.

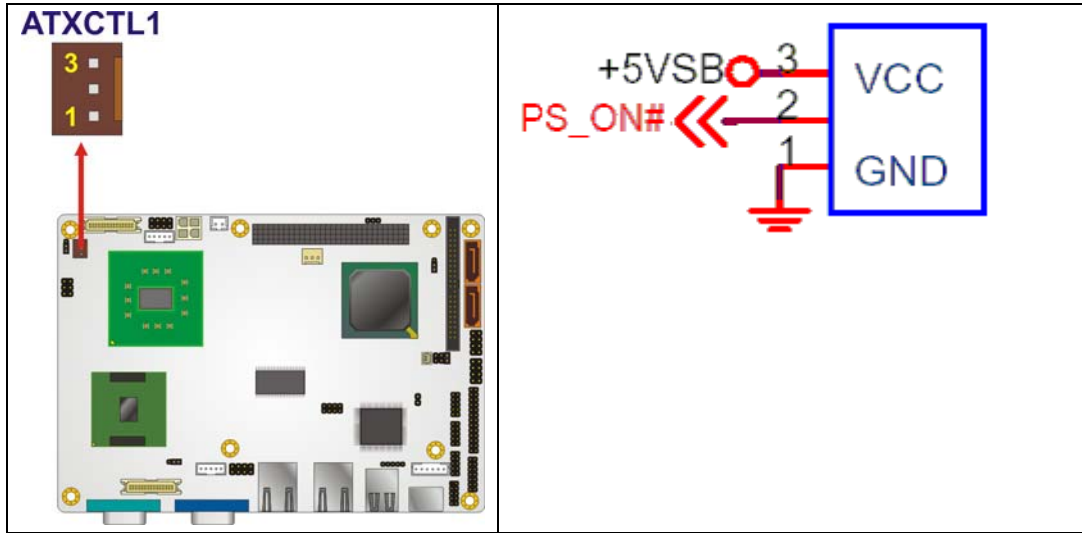

Figure 4-5: ATX Power Supply Enable Connector Location

PIN NO.	DESCRIPTION
1	GND
2	PS-ON
3	+5V Standby

Table 4-5: ATX Power Supply Enable Connector Pinouts

4.3.4 Audio Connector (9-pin)

- CN Label:** J_AUDIO1
- CN Type:** 9-pin header (2x5)
- CN Location:** See **Figure 4-6**
- CN Pinouts:** See **Table 4-6**

The 9-pin audio connector is connected to external audio devices including speakers and microphones for the input and output of audio signals to and from the system.

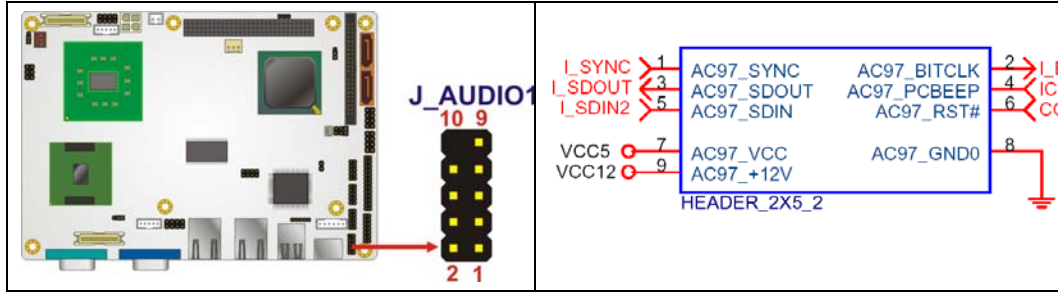

Figure 4-6: Audio Connector Location (9-pin)

PIN NO.	DESCRIPTION	PIN NO.	DESCRIPTION
1	SYNC	2	BITCLK
3	SDOUT	4	PCBEEP
5	SDIN	6	RST#
7	VCC	8	GND
9	+12V		

Table 4-6: Audio Connector Pinouts (9-pin)

4.3.5 Backlight Inverter Connector

CN Label: INVERTER1 and INVERTER2

CN Type: 5-pin wafer (1x5)

CN Location: See Figure 4-7

CN Pinouts: See Table 4-7

The backlight inverter connectors provide the backlights on the LCD display connected to the 3308440 with +12V of power.

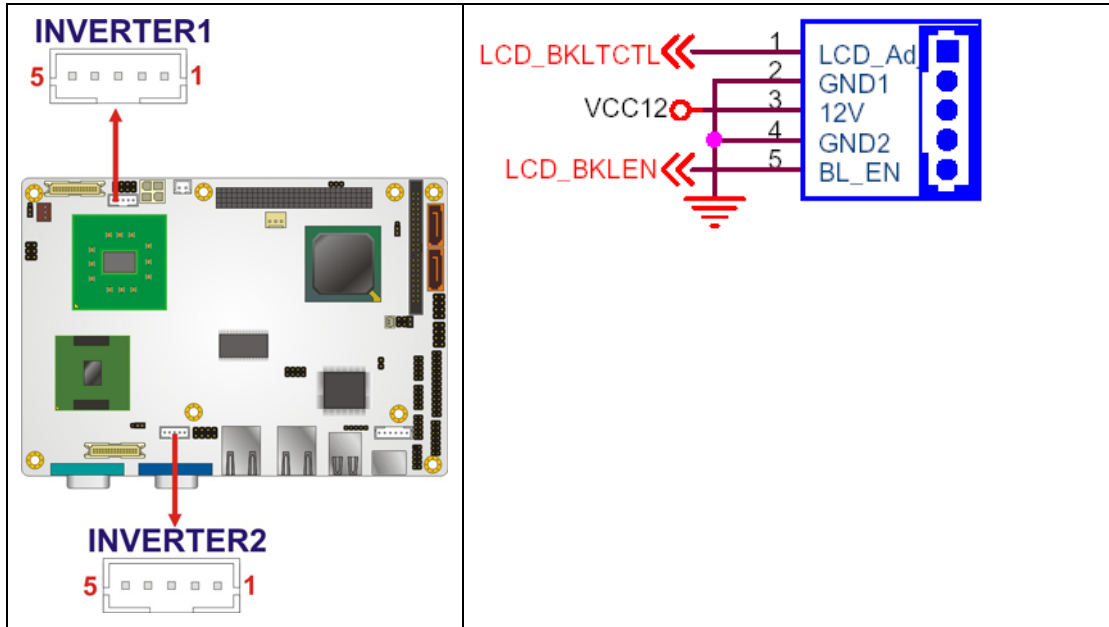

Figure 4-7: Panel Backlight Connector Pinout Locations

PIN NO.	DESCRIPTION
1	LCD Backlight Control
2	GROUND
3	+12V
4	GROUND
5	BACKLIGHT Enable

Table 4-7: Panel Backlight Connector Pinouts

4.3.6 CompactFlash® Socket

- CN Label:** CF1 (solder side)
- CN Type:** 50-pin header (2x25)
- CN Location:** See Figure 4-8
- CN Pinouts:** See Table 4-8

A CF Type I or Type II memory card is inserted to the CF socket on the solder side of the 3308440.

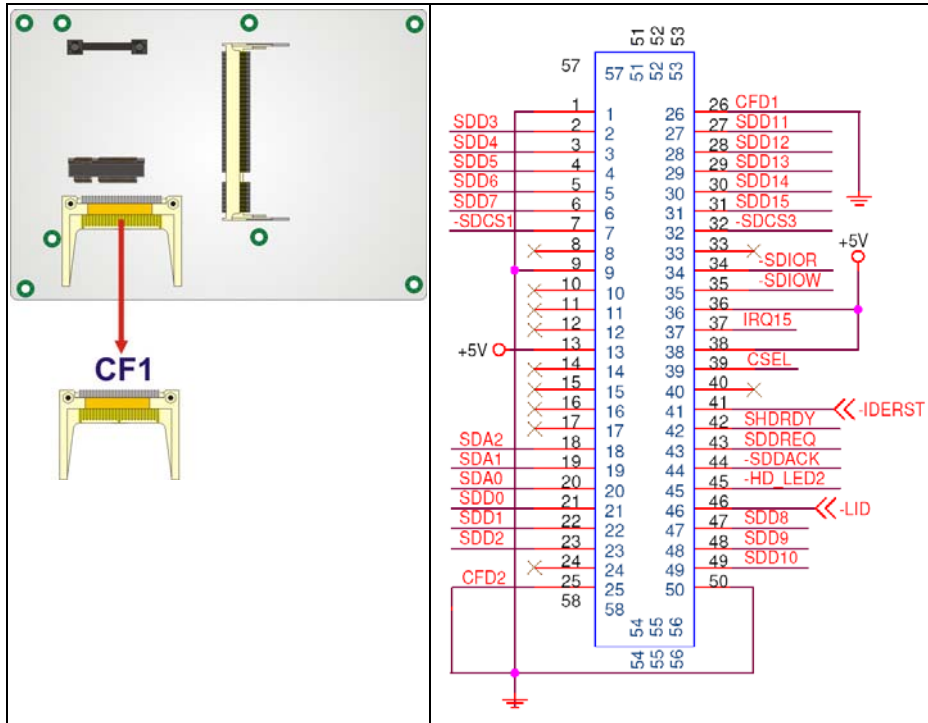

Figure 4-8: CF Card Socket Location

PIN NO.	DESCRIPTION	PIN NO.	DESCRIPTION
1	GROUND	26	VCC-IN CHECK1
2	DATA 3	27	DATA 11
3	DATA 4	28	DATA 12
4	DATA 5	29	DATA 13
5	DATA 6	30	DATA 14
6	DATA 7	31	DATA 15
7	HDC_CS0#	32	HDC_CS1
8	N/C	33	N/C
9	GROUND	34	IOR#
10	N/C	35	IOW#
11	N/C	36	VCC_COM
12	N/C	37	IRQ15
13	VCC_COM	38	VCC_COM
14	N/C	39	CSEL
15	N/C	40	N/C

PIN NO.	DESCRIPTION	PIN NO.	DESCRIPTION
16	N/C	41	HDD_RESET
17	N/C	42	IORDY
18	SA2	43	SDREQ
19	SA1	44	SDACK#
20	SA0	45	HDD_ACTIVE#
21	DATA 0	46	66DET
22	DATA 1	47	DATA 8
23	DATA 2	48	DATA 9
24	N/C	49	DATA 10
25	VCC-IN CHECK2	50	GROUND

Table 4-8: CF Card Socket Pinouts

4.3.7 Digital Input/Output (DIO) Connector

- CN Label:** DIO1
- CN Type:** 10-pin header (2x5)
- CN Location:** See Figure 4-9
- CN Pinouts:** See Table 4-9

The digital input/output connector is managed through a Super I/O chip. The DIO connector pins are user programmable.

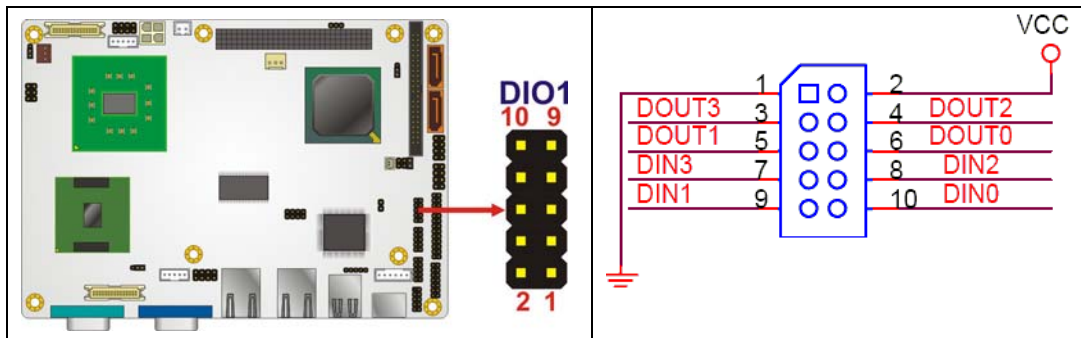

Figure 4-9: DIO Connector Connector Locations

PIN NO.	DESCRIPTION	PIN NO.	DESCRIPTION
1	GND	2	VCC
3	Output 3	4	Output 2
5	Output 1	6	Output 0
7	Input 3	8	Input 2
9	Input 1	10	Input 0

Table 4-9: DIO Connector Connector Pinouts

4.3.8 Fan Connector (+12V, 3-pin)

- CN Label:** CPU_FAN1
- CN Type:** 3-pin header
- CN Location:** See Figure 4-10
- CN Pinouts:** See Table 4-10

The cooling fan connector provides a 12V, 500mA current to the cooling fan. The connector has a "rotation" pin to get rotation signals from fans and notify the system so the system BIOS can recognize the fan speed. Please note that only specified fans can issue the rotation signals.

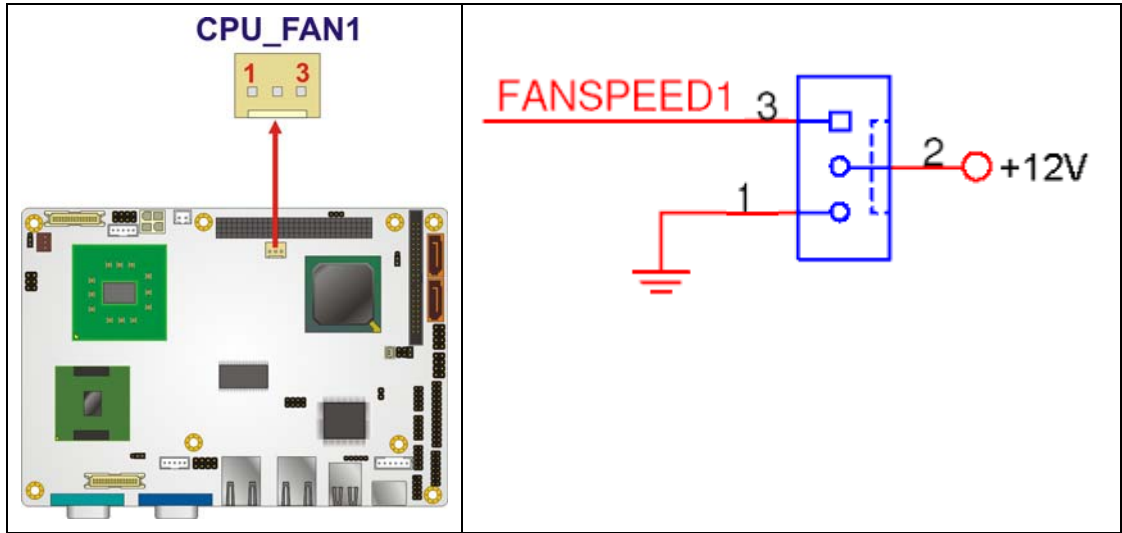

Figure 4-10: +12V Fan Connector Location

PIN NO.	DESCRIPTION
1	GND
2	+12V
3	Fan Speed Detect

Table 4-10: +12V Fan Connector Pinouts

4.3.9 Front Panel Connector (8-pin)

CN Label:	F_PANEL1
CN Type:	8-pin header (2x4)
CN Location:	See Figure 4-11
CN Pinouts:	See Table 4-11

The front panel connector connects to external switches and indicators to monitor and controls the motherboard. These indicators and switches include:

- Power button
- Reset
- Power LED

■ HDD LED

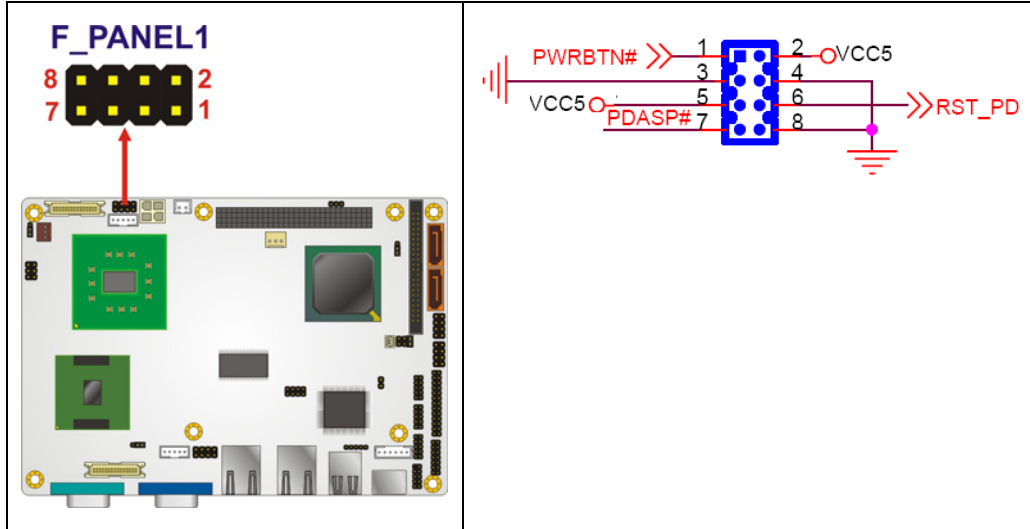

Figure 4-11: Front Panel Connector Pinout Locations (8-pin)

FUNCTION	PIN	DESCRIPTION	FUNCTION	PIN	DESCRIPTION
Power Button	1	PWR_BTN	Reset	5	VCC5
	2	GND	Button	6	GND
HDD LED	3	HDD_LED+	Reset	7	SYSRST-
	4	HDD_LED-		8	GND

Table 4-11: Front Panel Connector Pinouts (8-pin)

4.3.10 IDE Connector(44-pin)

- CN Label: IDE1
- CN Type: 44-pin header (2x22)
- CN Location: See Figure 4-12
- CN Pinouts: See Table 4-12

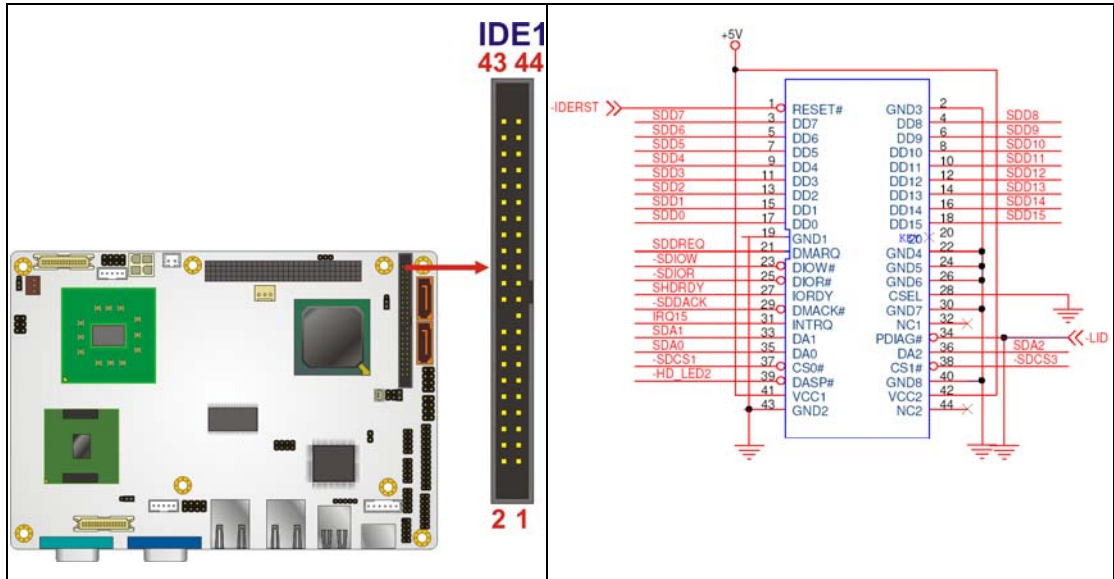

Figure 4-12: Secondary IDE Device Connector Locations

PIN NO.	DESCRIPTION	PIN NO.	DESCRIPTION
1	RESET#	2	GROUND
3	DATA 7	4	DATA 8
5	DATA 6	6	DATA 9
7	DATA 5	8	DATA 10
9	DATA 4	10	DATA 11
11	DATA 3	12	DATA 12
13	DATA 2	14	DATA 13
15	DATA 1	16	DATA 14
17	DATA 0	18	DATA 15
19	GROUND	20	N/C
21	IDE DRQ	22	GROUND
23	IOW#	24	GROUND
25	IOR#	26	GROUND
27	IDE CHRDY	28	GROUND
29	IDE DACK	30	GROUND-DEFAULT
31	INTERRUPT	32	N/C
33	SA1	34	N/C
35	SA0	36	SA2

37	HDC CS0#	38	HDC CS1#
39	HDD ACTIVE#	40	GROUND
41	VCC	42	VCC
43	GROUND	44	N/C

Table 4-12: Secondary IDE Connector Pinouts

4.3.11 Infrared Interface Connector (5-pin)

- CN Label:** IR1
- CN Type:** 5-pin header (1x5)
- CN Location:** See Figure 4-13
- CN Pinouts:** See Table 4-13

The infrared interface connector supports both Serial Infrared (SIR) and Amplitude Shift Key Infrared (ASKIR) interfaces.

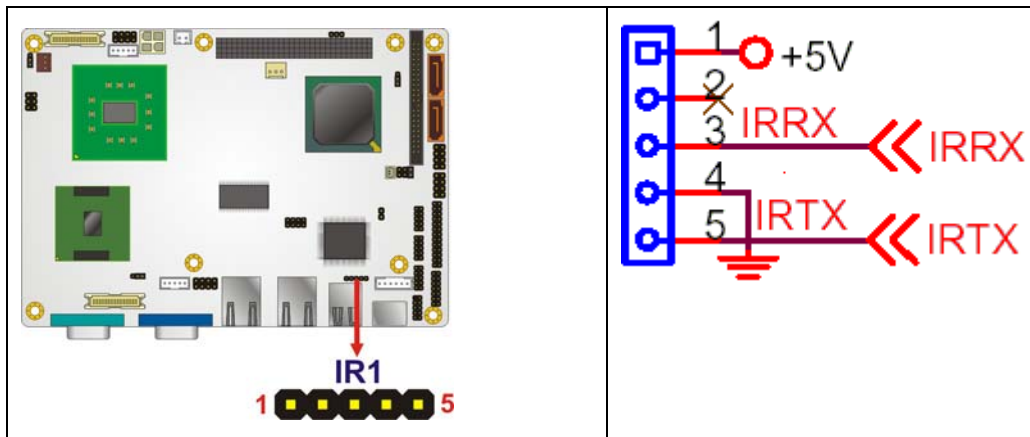

Figure 4-13: Infrared Connector Pinout Locations

PIN NO.	DESCRIPTION
1	VCC
2	NC
3	IR-RX
4	GND

5	IR-TX
---	-------

Table 4-13: Infrared Connector Pinouts

4.3.12 Keyboard/Mouse Connector

CN Label:	KB1
CN Type:	6-pin header (1x6)
CN Location:	See Figure 4-14
CN Pinouts:	See Table 4-14

The keyboard and mouse connector can be connected to a standard PS/2 cable or PS/2 Y-cable to add keyboard and mouse functionality to the system.

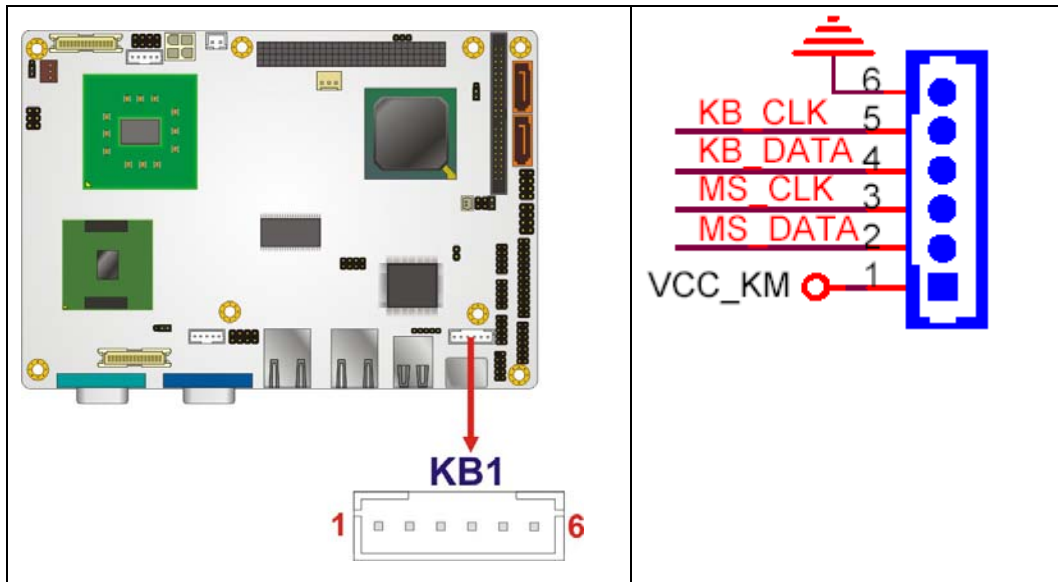

Figure 4-14: Keyboard/Mouse Connector Location

PIN NO.	DESCRIPTION
1	+5V KB DATA
2	MS DATA
3	MS CLK
4	KB DATA

PIN NO.	DESCRIPTION
5	KB CLK
6	GROUND

Table 4-14: Keyboard/Mouse Connector Pinouts

4.3.13 LVDS LCD Connector

- CN Label:** LVDS1 and LVDS2
- CN Type:** 30-pin crimp (2x10)
- CN Location:** See Figure 4-15
- CN Pinouts:** See Table 4-15

The 30-pin LVDS LCD connectors can be connected to single channel or dual channel, 24-bit or 36-bit LVDS panel.

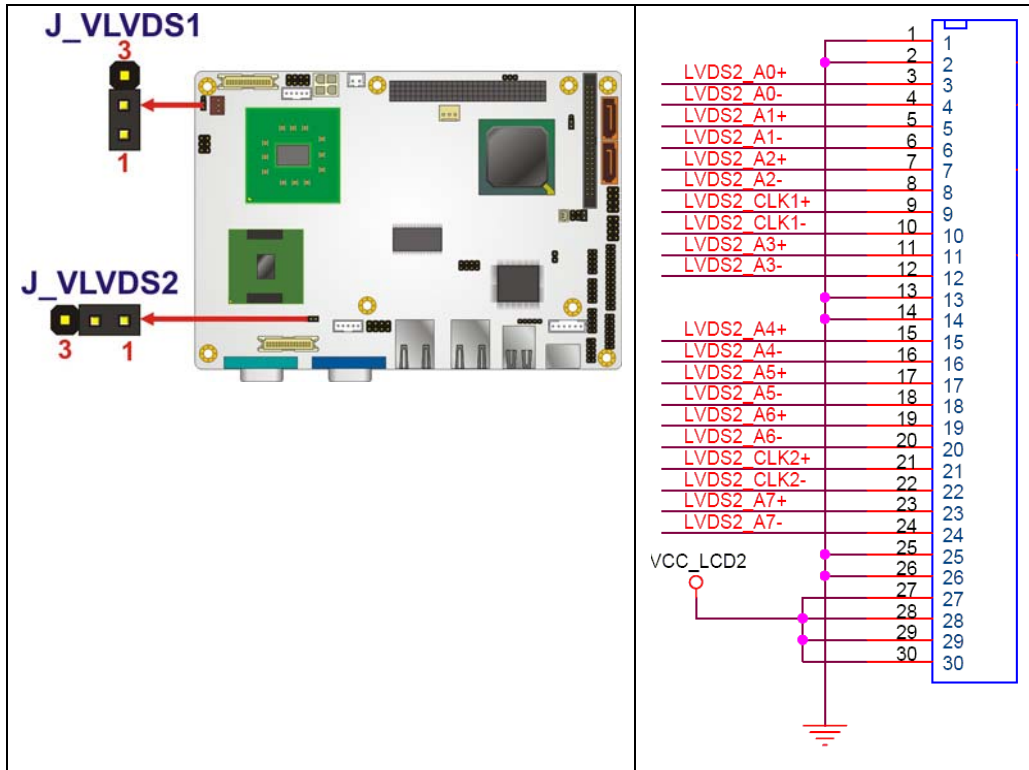

Figure 4-15: LVDS LCD Connector Pinout Locations

PIN NO.	DESCRIPTION	PIN NO.	DESCRIPTION
1	GND1	2	GND2
3	A_Y0	4	A_Y0#
5	A_Y1	6	A_Y1#
7	A_Y2	8	A_Y2#
9	A_CK	10	A_CK#
11	NC	12	NC
13	GND3	14	GND4
15	B_Y0	16	B_Y0#
17	B_Y1	18	B_Y1#
19	B_Y2	20	B_Y2#
21	B_CK	22	B_CK#
23	NC	24	NC
25	GND5	26	GND6
27	VCC_LCD	28	VCC_LCD
29	VCC_LCD	30	VCC_LCD

Table 4-15: LVDS LCD Port Connector Pinouts

4.3.14 Parallel Port Connector

- CN Label:** LPT1
- CN Type:** 26-pin header
- CN Location:** See **Figure 4-16**
- CN Pinouts:** See **Table 4-16**

The 26-pin parallel port connector connects to a parallel port connector interface or some other parallel port device such as a printer.

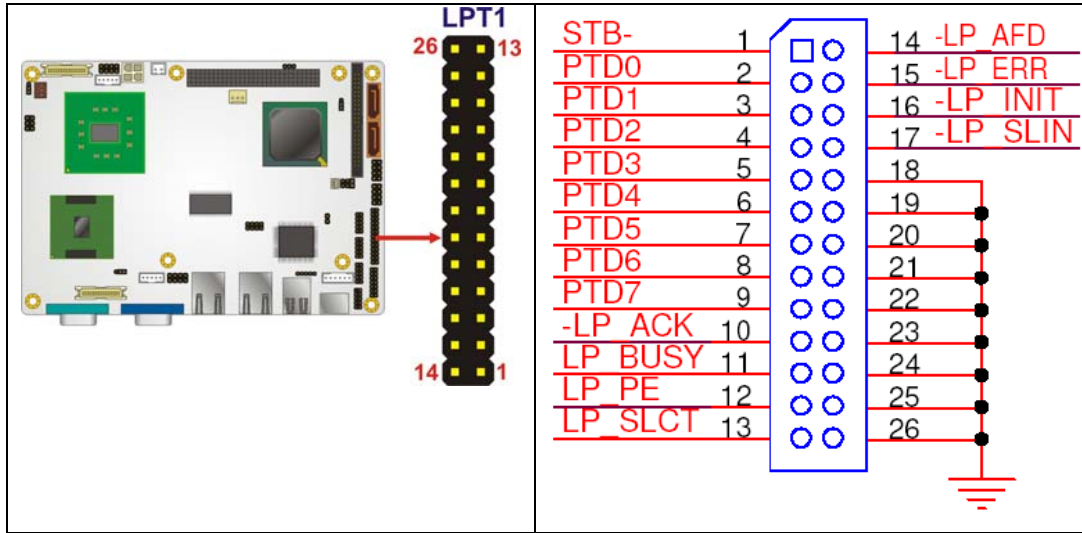

Figure 4-16: Parallel Port Connector Location

PIN NO.	DESCRIPTION	PIN NO.	DESCRIPTION
1	STROBE#	2	DATA 0
3	DATA 1	4	DATA 2
5	DATA 3	6	DATA 4
7	DATA 5	8	DATA 6
9	DATA 7	10	ACKNOWLEDGE
11	BUSY	12	PAPER EMPTY
13	PRINTER SELECT	14	AUTO FORM FEED #
15	ERROR#	16	INITIALIZE
17	PRINTER SELECT LN#	18	GROUND
19	GROUND	20	GROUND
21	GROUND	22	GROUND
23	GROUND	24	GROUND
25	GROUND	26	NC

Table 4-16: Parallel Port Connector Pinouts

4.3.15 PCIe Mini Card Slot

CN Label: CN4

CN Type: 52-pin Mini PCIe Card Slot

CN Location: See Figure 4-17

CN Pinouts: See Table 4-17

The PCIe mini card slot enables a PCIe mini card expansion module to be connected to the board. Cards supported include among others wireless LAN (WLAN) cards.

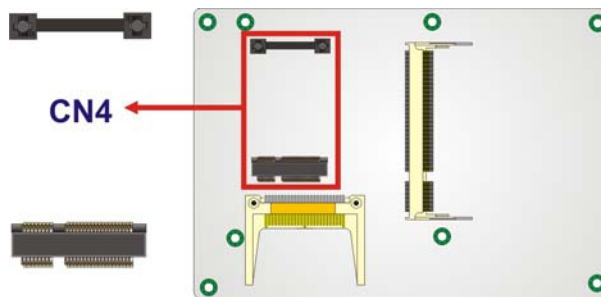

Figure 4-17: PCIe Mini Card Slot Location

PIN NO.	DESCRIPTION	PIN NO.	DESCRIPTION
1	PCIE_WAKE#	2	VCC3
3	N/C	4	GND
5	N/C	6	1.5V
7	CLKREQ#	8	LFRAME#
9	GND	10	LAD3
11	CLK-	12	LAD2
13	CLK+	14	LAD1
15	GND	16	LAD0
17	PCIRST#	18	GND
19	LPC	20	VCC3
21	GND	22	PCIRST#
23	PERN2	24	3VDual
25	PERP2	26	GND
27	GND	28	1.5V
29	GND	30	SMBCLK

31	PETN2	32	SMBDATA
33	PETP2	34	GND
35	GND	36	USB D-
37	N/C	38	USB D+
39	N/C	40	GND
41	N/C	42	N/C
43	N/C	44	RF_LINK#
45	N/C	46	BLUELED#
47	N/C	48	1.5V
49	N/C	50	GND
51	N/C	52	VCC3

Table 4-17: PCIe Mini Card Slot Pinouts

4.3.16 PCI-104 Slot

- CN Label:** PC104_PLUS1
- CN Type:** 120-pin PCI-104 slot
- CN Location:** See **Figure 4-18**
- CN Pinouts:** See **Table 4-18**

The PCI-104 slot enables a PCI-104 compatible expansion module to be connected to the board.

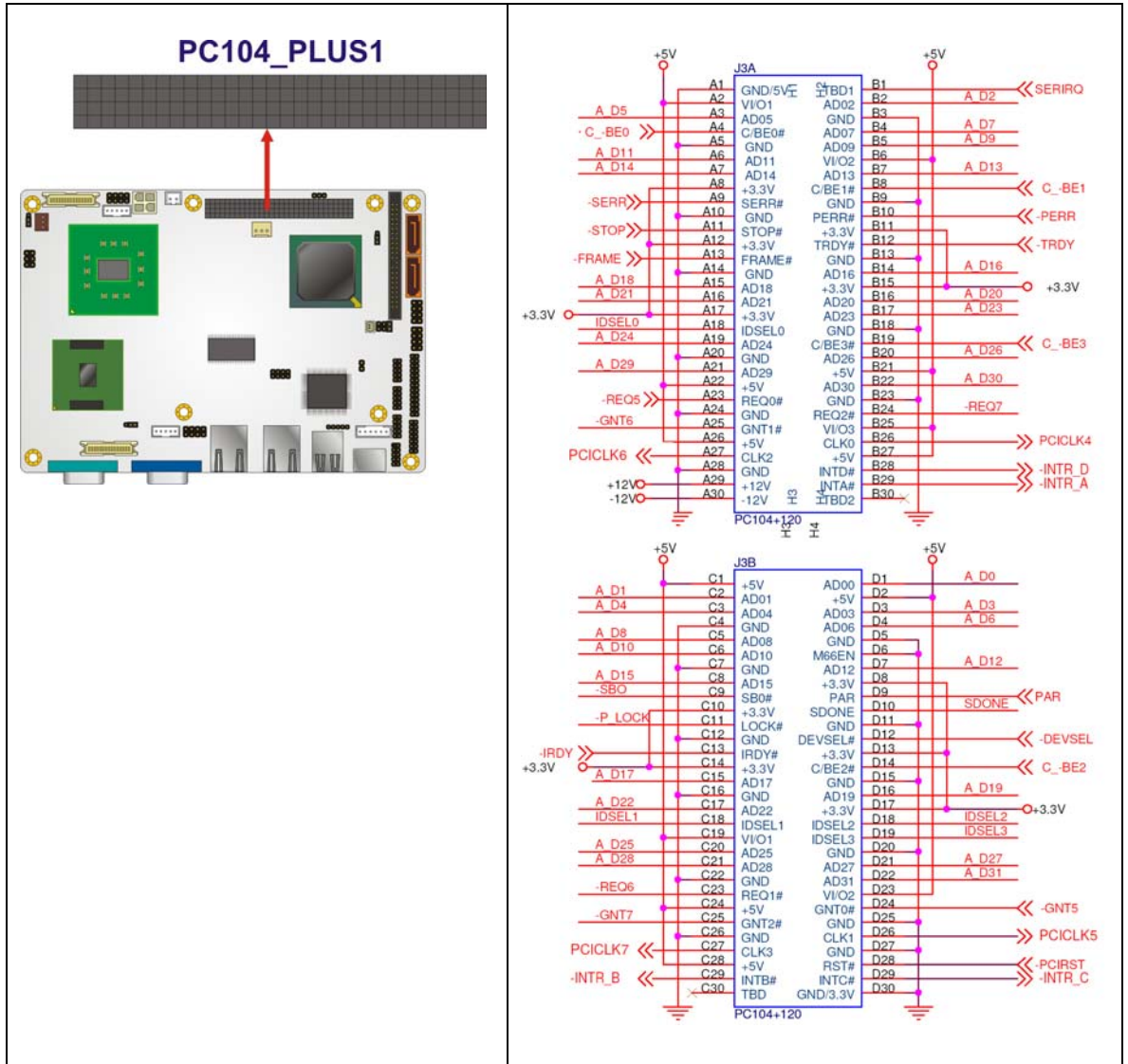

Figure 4-18: PCI-104 Slot Location

Pin No.	Column A	Column B	Column C	Column D
1	GND/5V	TBD1	5V	AD00
2	VI/O1	AD02	AD01	+5V
3	AD05	GND	AD04	AD03
4	C/BE0#	AD07	GND	AD06
5	GND	AD09	AD08	GND
6	AD11	VI/O2	AD10	M66EN

Pin No.	Column A	Column B	Column C	Column D
7	AD14	AD13	GND	AD12
8	+3.3V	C/BE1#	AD15	+3.3V
9	SERR#	GND	SBO#	PAR
10	GND	PERR#	+3.3V	SDONE
11	STOP#	+3.3V	LOCK#	GND
12	+3.3V	TRDY#	GND	DEVSEL#
13	FRAME#	GND	IRDY#	+3.3V
14	GND	AD16	+3.3V	C/BE2#
15	AD18	+3.3V	AD17	GND
16	AD21	AD20	GND	AD19
17	+3.3V	AD23	AD22	+3.3V
18	IDSEL0	GND	IDSEL1	IDSEL2
19	AD24	C/BE3#	VI/O1	IDSEL3
20	GND	AD26	AD25	GND
21	AD29	+5V	AD28	AD27
22	+5V	AD30	GND	AD31
23	REQ0#	GND	REQ1#	VI/O2
24	GND	REQ2#	+5V	GNT0#
25	GNT1#	VI/O3	GNT2#	GND
26	+5V	CLK0	GND	CLK1
27	CLK2	+5V	CLK3	GND
28	GND	INTD#	+5V	RST#
29	+12V	INTA#	INTB#	INTC#
30	-12V	TBD2	TBD	GND/3.3V

Table 4-18: PCI-104 Slot Connector Pinouts

4.3.17 SATA Drive Connectors

- CN Label:** SATA1, SATA2
- CN Type:** 7-pin SATA drive connectors
- CN Location:** See Figure 4-19
- CN Pinouts:** See Table 4-19

The four SATA drive connectors are each connected to a first generation SATA drive. First generation SATA drives transfer data at speeds as high as 150Mb/s. The SATA drives can be configured in a RAID configuration.

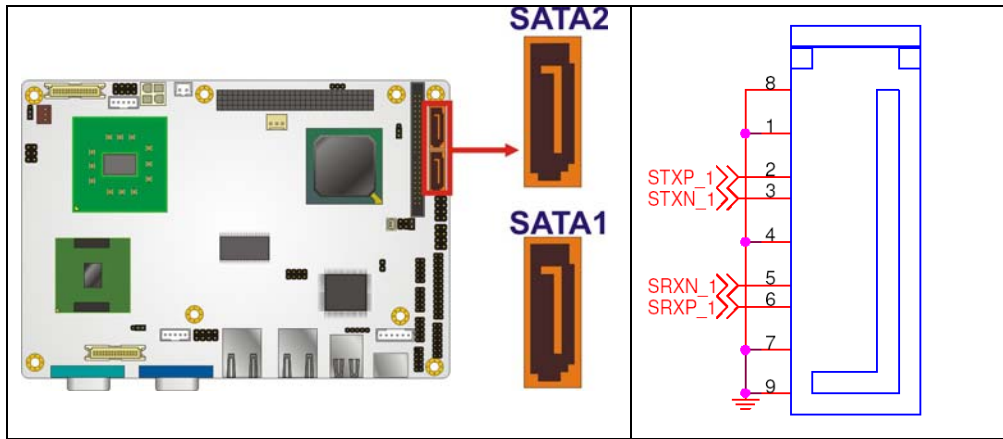

Figure 4-19: SATA Drive Connector Locations

PIN NO.	DESCRIPTION
1	GND
2	TX+
3	TX-
4	GND
5	RX-
6	RX+
7	GND

Table 4-19: SATA Drive Connector Pinouts

4.3.18 Serial Port Connectors (COM 3 and COM4)

- CN Label:** COM3 and COM4
- CN Type:** 10-pin header (2x5)
- CN Location:** See Figure 4-20
- CN Pinouts:** See Table 4-20

The 10-pin serial port connector provides a second RS-232 serial communications channel. The COM serial port connectors can be connected to external RS-232 serial port devices.

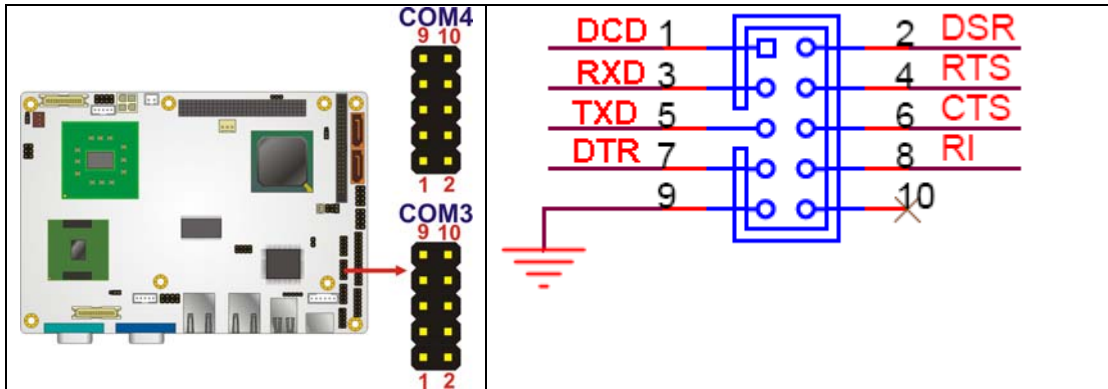

Figure 4-20: COM Connector Pinout Locations

PIN NO.	DESCRIPTION	PIN NO.	DESCRIPTION
1	Data Carrier Direct (DCD)	2	Data Set Ready (DSR)
3	Receive Data (RXD)	4	Request To Send (RTS)
5	Transmit Data (TXD)	6	Clear To Send (CTS)
7	Data Terminal Ready (DTR)	8	Ring Indicator (RI)
9	Ground (GND)	10	N/C

Table 4-20: COM Connector Pinouts

4.3.19 Serial Port Connector (COM 2)(RS-232, RS-422 or RS-485)

- CN Label:** COM2

CN Type: 14-pin header (2x7)

CN Location: See Figure 4-21

CN Pinouts: See Table 4-21

The 14-pin serial port connector connects to the COM2 serial communications channels. COM2 is a multi function channel. In default mode COM2 is an RS-232 serial communication channel but, with the COM2 function select jumper, can be configured as either an RS-422 or RS-485 serial communications channel.

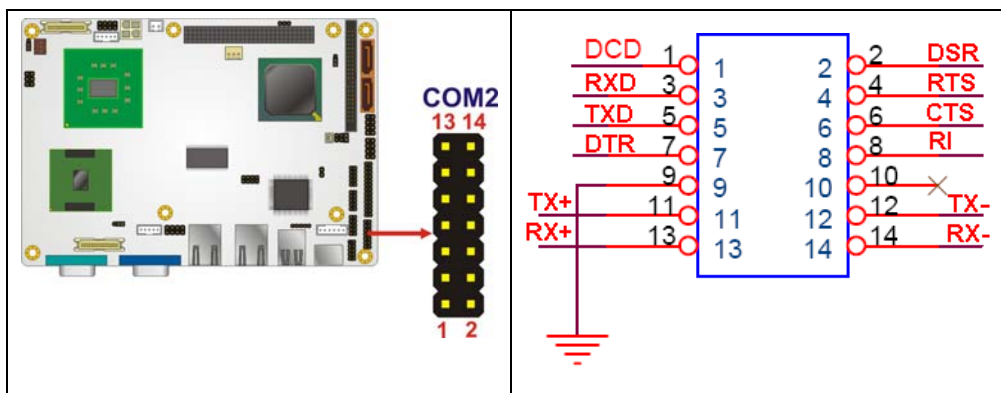

Figure 4-21: RS-232/422/485 Serial Port Connector Location

PIN NO.	DESCRIPTION	PIN NO.	DESCRIPTION
1	NDCD	2	NDSR2
3	NRX	4	NRTS2
5	NTX	6	NCTS2
7	NDTR	8	NR12
9	GND	10	GND
11	TXD485+	12	TXD485-
13	RXD485+	14	RXD485-

Table 4-21: RS-232/RS-485 Serial Port Connector Pinouts

4.3.20 TV Out Connector

CN Label: TV1

CN Type: 6-pin header (2x3)

CN Location: See Figure 4-22

CN Pinouts: See Table 4-22

The 2x3 pin TV out connector connects to a TV output by using an S-Video or RCA connector. The TV out connector makes displaying media data on a television easier.

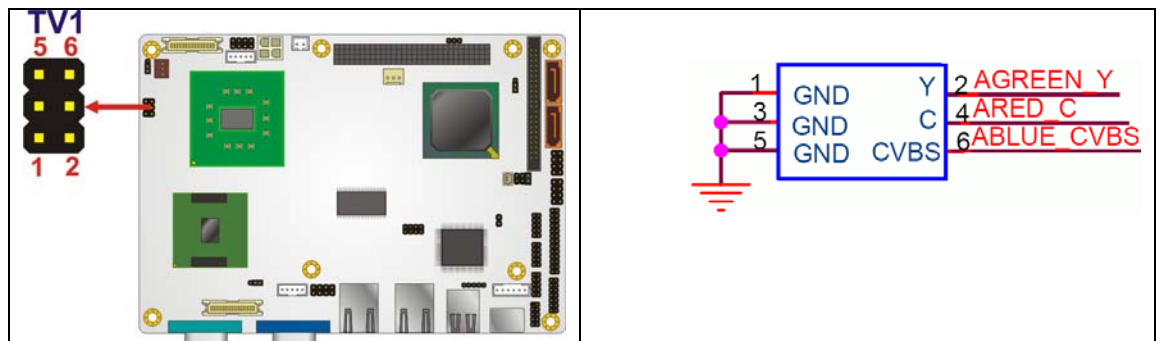

Figure 4-22: TV Connector Pinout Locations

PIN NO.	DESCRIPTION	PIN NO.	DESCRIPTION
1	GND	2	IOY
3	GND	4	IOC
5	GND	6	IOCOMP

Table 4-22: TV Port Connector Pinouts

4.3.21 USB Connectors (Internal)

CN Label: USB01 and USB23

CN Type: 8-pin header (2x4)

CN Location: See Figure 4-23

CN Pinouts: See Table 4-23

The 2x4 USB pin connectors each provide connectivity to two USB 1.1 or two USB 2.0 ports. Each USB connector can support two USB devices. Additional external USB ports are found on the rear panel. The USB ports are used for I/O bus expansion.

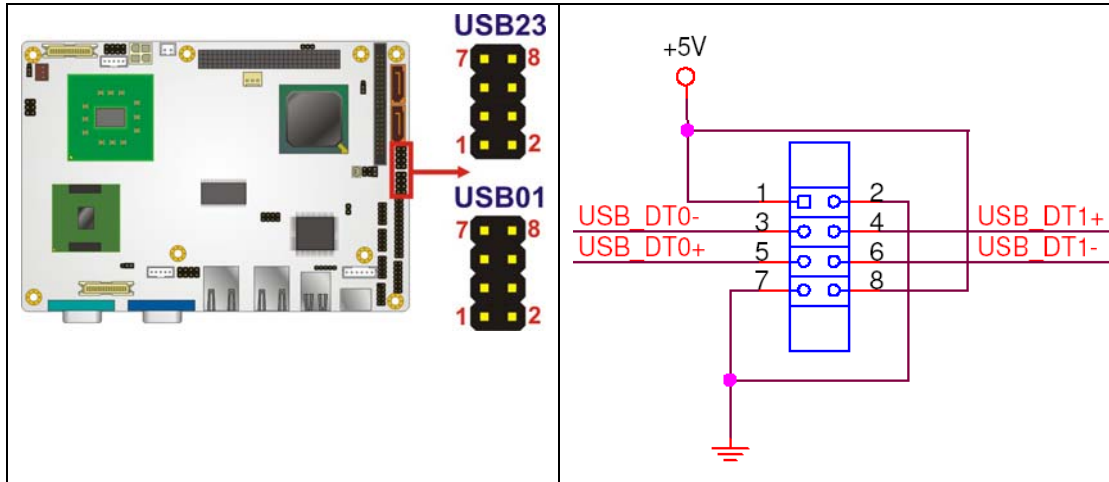

Figure 4-23: USB Connector Pinout Locations

PIN NO.	DESCRIPTION	PIN NO.	DESCRIPTION
1	VCC	2	GND
3	DATAN-	4	DATA1M-
5	DATAN+	6	DATAM+
7	GND	8	VCC

Table 4-23: USB Port Connector Pinouts

4.4 External Peripheral Interface Connector Panel

Figure 4-24 shows the 3308440 epic external peripheral interface connector (EPIC) panel. The 3308840 EPIC panel consists of the following:

- 2 x RJ-45 LAN connectors
- 1 x PS/2 connectors
- 1 x Serial port connectors
- 2 x USB connectors
- 1 x VGA connector

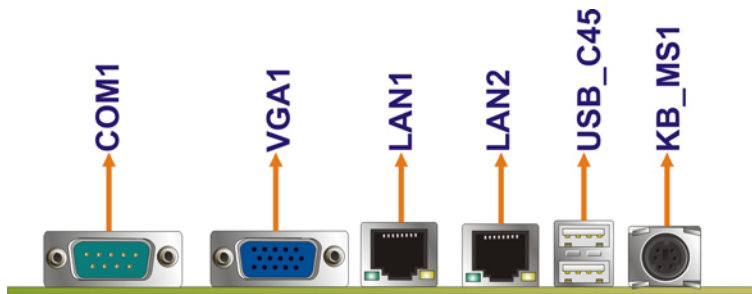

Figure 4-24: 3308440 External Peripheral Interface Connector

4.4.1 Keyboard/Mouse Connector

- CN Label: KB/MS
- CN Type: PS/2
- CN Location: See **Figure 4-24** (labeled 1)
- CN Pinouts: See Figure 4-25, Table 4-24

The 3308440 keyboard and mouse connector is a standard PS/2 connector.

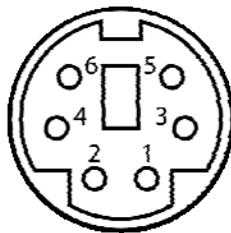

Figure 4-25: PS/2 Pinout and Configuration

PIN	DESCRIPTION
1	KB DATA
2	MS DATA
3	GND
4	VCC
5	KB CLOCK
6	MS CLOCK

PIN	DESCRIPTION
-----	-------------

Table 4-24: Keyboard Connector Pinouts

4.4.2 LAN Connectors

CN Label: LAN1 and LAN2

CN Type: RJ-45

CN Location: See Figure 4-24

CN Pinouts: See Table 4-25

The 3308440 is equipped with two built-in RJ-45 Ethernet controllers. The controllers can connect to the LAN through two RJ-45 LAN connectors. There are two LEDs on the connector indicating the status of LAN. The pin assignments are listed in the following table:

PIN	DESCRIPTION	PIN	DESCRIPTION
1	MDIA3-	5	MDIA1+
2	MDIA3+	6	MDIA2+
3	MDIA2-	7	MDIA0-
4	MDIA1-	8	MDIA0+

Table 4-25: LAN Pinouts

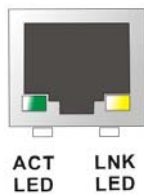

Figure 4-26: RJ-45 Ethernet Connector

The RJ-45 Ethernet connector has two status LEDs, one green and one yellow. The green LED indicates activity on the port and the yellow LED indicates the port is linked. See **Table 4-26**.

STATUS	DESCRIPTION	STATUS	DESCRIPTION
GREEN	Activity	YELLOW	Linked

Table 4-26: RJ-45 Ethernet Connector LEDs

4.4.3 Serial Port Connector (COM1)

- CN Label:** COM1
- CN Type:** DB-9 connectors
- CN Location:** See Figure 4-24 (see 2)
- CN Pinouts:** See Table 4-27 and Figure 4-27

The 9-pin DB-9 serial port connectors are connected to RS-232 serial communications devices.

PIN NO.	DESCRIPTION	PIN NO.	DESCRIPTION
1	DCD	6	DSR
2	RX	7	RTS
3	TX	8	CTS
4	DTR	9	RI
5	GND		

Table 4-27: RS-232 Serial Port (COM 1) Pinouts

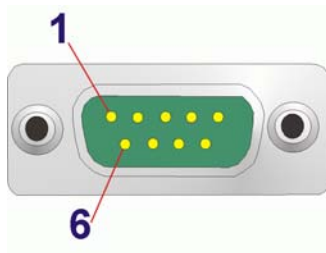

Figure 4-27: COM1 Pinout Locations

4.4.4 USB Connectors

- CN Label:** USB
- CN Type:** Dual USB port
- CN Location:** See Figure 4-24
- CN Pinouts:** See Table 4-28

The 3308440 has two external USB 2.0 ports. The ports connect to both USB 2.0 and USB 1.1 devices.

PIN NO.	DESCRIPTION	PIN NO.	DESCRIPTION
1	VCC	5	VCC
2	DATA-	6	DATA-
3	DATA+	7	DATA+
4	GND	8	GND

Table 4-28: USB Port Pinouts

4.4.5 VGA Connector

- CN Label:** VGA1
- CN Type:** 15-pin Female
- CN Location:** See Figure 4-24
- CN Pinouts:** See Figure 4-28 and Table 4-29

The 3308440 has a single 15-pin female connector for connectivity to standard display devices.

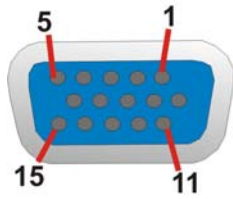

Figure 4-28: VGA Connector

PIN	DESCRIPTION	PIN	DESCRIPTION
1	RED	2	GREEN
3	BLUE	4	NC
5	GND	6	CRT_PLUG-
7	GND	8	GND
9	VCC	10	GND
11	NC	12	DDC DAT
13	HSYNC	14	VSYNC
15	DDCCLK		

Table 4-29: VGA Connector Pinouts

Chapter

5

Installation

5.1 Anti-static Precautions



WARNING:

Failure to take ESD precautions during the installation of the 3308440 may result in permanent damage to the 3308440 and severe injury to the user.

Electrostatic discharge (ESD) can cause serious damage to electronic components, including the 3308440 SBC. Dry climates are especially susceptible to ESD. It is therefore critical that whenever the 3308440 SBC, or any other electrical component is handled, the following anti-static precautions are strictly adhered to.

- **Wear an anti-static wristband:** - Wearing a simple anti-static wristband can help to prevent ESD from damaging the board.
- **Self-grounding:**- Before handling the board touch any grounded conducting material. During the time the board is handled, frequently touch any conducting materials that are connected to the ground.
- **Use an anti-static pad:** When configuring the 3308440, place it on an anti-static pad. This reduces the possibility of ESD damaging the 3308440.
- **Only handle the edges of the PCB:-:** When handling the PCB, hold the PCB by the edges.

5.2 Installation Considerations



NOTE:

The following installation notices and installation considerations should be read and understood before the 3308440 is installed. All installation notices pertaining to the installation of the 3308440 should be strictly adhered to. Failing to adhere to these precautions may lead to severe damage of the 3308440 and injury to the person installing the motherboard.

5.2.1 Installation Notices



WARNING:

The installation instructions described in this manual should be carefully followed in order to prevent damage to the 3308440, 3308440 components and injury to the user.

Before and during the installation please **DO** the following:

- Read the user manual:
 - The user manual provides a complete description of the 3308440 installation instructions and configuration options.
- Wear an electrostatic discharge cuff (ESD):
 - Electronic components are easily damaged by ESD. Wearing an ESD cuff removes ESD from the body and helps prevent ESD damage.
- Place the 3308440 on an antistatic pad:
 - When installing or configuring the motherboard, place it on an antistatic pad. This helps to prevent potential ESD damage.
- Turn all power to the 3308440 off:

-
- When working with the 3308440, make sure that it is disconnected from all power supplies and that no electricity is being fed into the system.

Before and during the installation of the 3308440 DO NOT:

- Remove any of the stickers on the PCB board. These stickers are required for warranty validation.
- Use the product before verifying all the cables and power connectors are properly connected.
- Allow screws to come in contact with the PCB circuit, connector pins, or its components.

5.2.2 Installation Checklist

The following checklist is provided to ensure the 3308440 is properly installed.

- All the items in the packing list are present
- A compatible memory module is properly inserted into the slot
- The CF Type I or CF Type II card is properly installed into the CF socket
- The jumpers have been properly configured
- The 3308440 SBC is inserted into a chassis with adequate ventilation
- The correct power supply is being used
- The following devices are properly connected
 - Primary and secondary IDE device
 - SATA drives
 - Power supply
 - USB cable
 - Serial port cable
- The following external peripheral devices are properly connected to the chassis:
 - VGA screen
 - Keyboard
 - Mouse
 - RS-232 serial communications device
 - USB devices

5.3 Unpacking

When the 3308440 is unpacked, please check all the unpacking list items listed in Chapter 3 are indeed present. If any of the unpacking list items are not available please contact the 3308440 card vendor reseller/vendors

5.4 SO-DIMM and CF Card Installation

5.4.1 SO-DIMM Installation



WARNING:

Using incorrectly specified SO-DIMM may cause permanently damage the 3308440. Please make sure the purchased SO-DIMM complies with the memory specifications of the 3308440. SO-DIMM specifications compliant with the 3308440 are listed in **Chapter 2.**

To install a SO-DIMM into a SO-DIMM socket, please follow the steps below and refer to **Figure 5-1.**

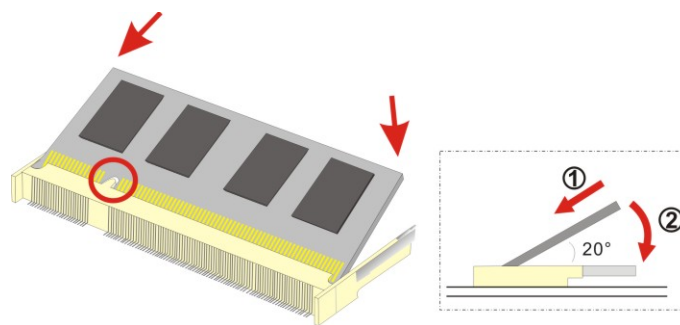

Figure 5-1: SO-DIMM Installation

Step 1: **Locate the SO-DIMM socket.** Place the 3308440 on an anti-static pad with the solder side facing up.

Step 2: Align the SO-DIMM with the socket. The SO-DIMM must be oriented in such a way that the notch in the middle of the SO-DIMM must be aligned with the plastic bridge in the socket.

Step 3: Insert the SO-DIMM. Push the SO-DIMM chip into the socket at an angle. (See **Figure 5-1**)

Step 4: Open the SO-DIMM socket arms. Gently pull the arms of the SO-DIMM socket out and push the rear of the SO-DIMM down. (See **Figure 5-1**)

Step 5: Secure the SO-DIMM. Release the arms on the SO-DIMM socket. They clip into place and secure the SO-DIMM in the socket.

5.4.2 CF Card Installation



NOTE:

The 3308440 can support both CF Type I cards and CF Type II cards. For the complete specifications of the supported CF cards please refer to **Chapter 2**.

To install the a CF card (Type 1 or Type 2) onto the 3308440, please follow the steps below:

Step 1: Locate the CF card socket. Place the 3308440 on an anti-static pad with the solder side facing up. Locate the CF card.

Step 2: Align the CF card. Make sure the CF card is properly aligned with the CF socket.

Step 3: Insert the CF card. Gently insert the CF card into the socket making sure the socket pins are properly inserted into the socket. See **Figure 5-2**.

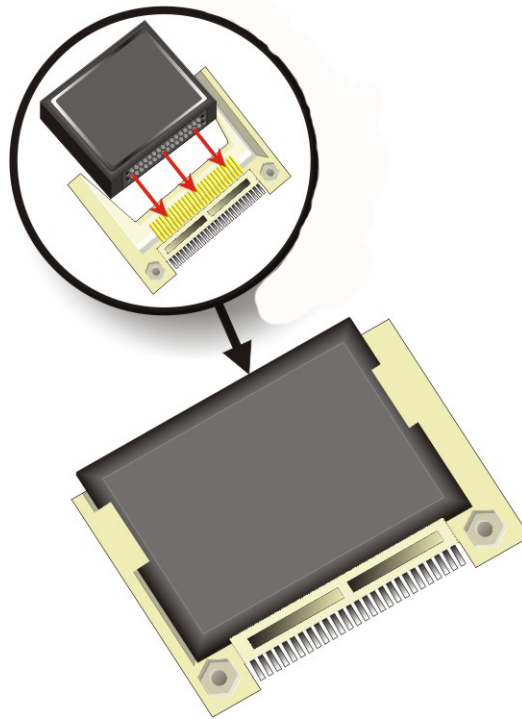

Figure 5-2: CF Card Installation

5.5 Jumper Settings



NOTE:

A jumper is a metal bridge used to close an electrical circuit. It consists of two or three metal pins and a small metal clip (often protected by a plastic cover) that slides over the pins to connect them. To CLOSE/SHORT a jumper means connecting the pins of the jumper with the plastic clip and to OPEN a jumper means removing the plastic clip from a jumper.

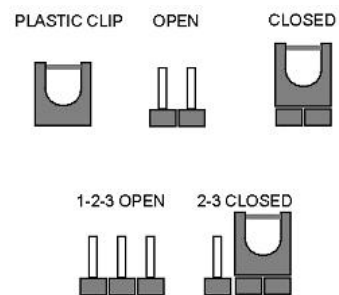

Description	Label	Type
AT Power Mode Setting	ATXCTL1	2-pin header
CF Card Setting	JCF1	2-pin header
Clear CMOS	J_CMOS1	3-pin header
COM2 Mode Setting	JP1	6-pin header
LVDS1 Panel Resolution	J_LCD_TYPE1	8-pin header
LVDS1 Voltage Select	J_VLVDS1	3-pin header
LVDS2 Voltage Select	J_VLVDS2	3-pin header
PCI-104 VIO Select	JP2	3-pin header

Table 5-1: Jumpers

5.5.1 AT Power Select Jumper Settings



NOTE:

The AT Power Select Jumper is the same as the ATX Enable connector.

- Jumper Label:** ATXCTI1
- Jumper Type:** 3-pin header
- Jumper Settings:** See **Table 5-2**
- Jumper Location:** See Figure 5-4

The AT Power Select jumper specifies the systems power mode as AT or ATX. Use a jumper cap to short pin 1 - pin 2 on the ATXCTL1 connector to enable the AT Power mode on the system. In the ATX mode use the PS_ON- and 5VSB cable. AT Power Select jumper settings are shown in **Table 5-2**.

AT Power Select	Description	
Short 1 – 2	Use AT power	Default
Open	Use ATX power	

Table 5-2: AT Power Select Jumper Settings

The location of the AT Power Select jumper is shown in Figure 5-4 below.

ATXCTL1

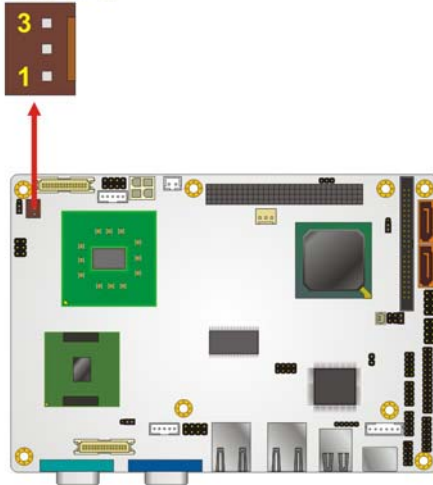

Figure 5-4: AT Power Select Jumper Location

5.5.2 CF Card Setup

Jumper Label:	JCF1
Jumper Type:	2-pin header
Jumper Settings:	See Table 5-3
Jumper Location:	See Figure 5-5

The CF Card Setup jumper sets the CF Type I card or CF Type II cards as either the slave device or the master device. CF Card Setup jumper settings are shown in Table 5-3.

CF Card Setup	Description	
Open	Slave	Default
Closed	Master	

Table 5-3: CF Card Setup Jumper Settings

The CF Card Setup jumper location is shown in Figure 5-5.

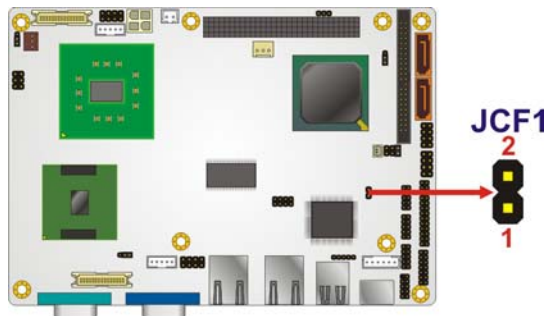

Figure 5-5: CF Card Setup Jumper Location

5.5.3 Clear CMOS Jumper

Jumper Label:	J_CMOS1
Jumper Type:	3-pin header
Jumper Settings:	See Table 5-4
Jumper Location:	See Figure 5-6

If the 3308440 SBC fails to boot due to improper BIOS settings, the clear CMOS jumper clears the CMOS data and resets the system BIOS information. To do this, use the jumper cap to close pins 2 and 3 for a few seconds then reinstall the jumper clip back to pins 1 and 2.

If the “CMOS Settings Wrong” message is displayed during the boot up process, the fault may be corrected by pressing the F1 to enter the CMOS Setup menu. Do one of the following:

- Enter the correct CMOS setting

- Load Optimal Defaults
- Load Failsafe Defaults.

After having done one of the above, save the changes and exit the CMOS Setup menu.

The clear CMOS jumper settings are shown in **Table 5-4**.

AT Power Select	Description	
Short 1 - 2	Keep CMOS Setup	Default
Short 2 - 3	Clear CMOS Setup	

Table 5-4: Clear CMOS Jumper Settings

The location of the clear CMOS jumper is shown in **Figure 5-6** below.

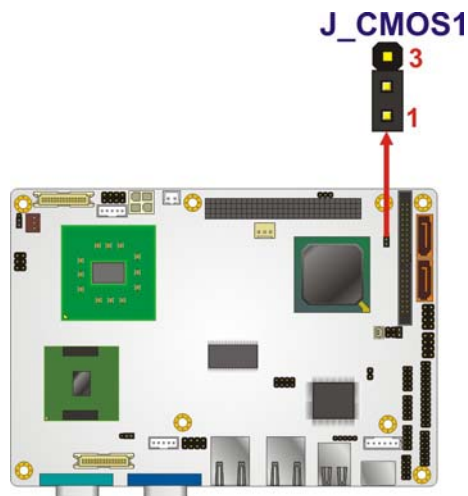

Figure 5-6: Clear CMOS Jumper

5.5.4 COM 2 Function Select Jumper

- Jumper Label:** JP1
- Jumper Type:** 6-pin header
- Jumper Settings:** See **Table 5-5**
- Jumper Location:** See **Figure 5-7**

The COM 2 Function Select jumper sets the communication protocol used by the second serial communications port (COM 2) as RS-232, RS-422 or RS-485. The COM 2 Function Select settings are shown in **Table 5-5**.

COM 2 Function Select	Description	
Short 1-2	RS-232	Default
Short 3-4	RS-422	
Short 5-6	RS-485	

Table 5-5: COM 2 Function Select Jumper Settings

The COM 2 Function Select jumper location is shown in **Figure 5-7**.

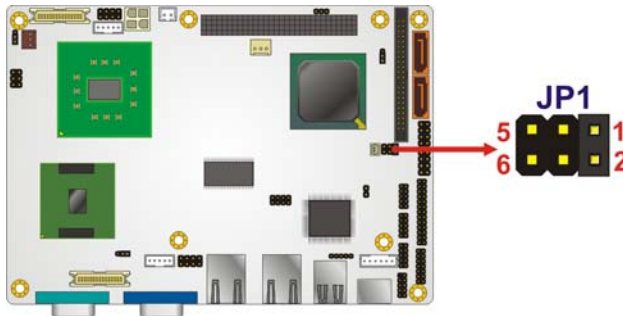

Figure 5-7: COM 2 Function Select Jumper Location

5.5.5 LVDS1 Panel Resolution Jumper

Jumper Label:	J_LCD_TYPE1
Jumper Type:	8-pin header
Jumper Settings:	See Table 5-6
Jumper Location:	See Figure 5-8

The LVDS1 Panel Resolution jumper allows the resolution of the LVDS screens connected to the LVDS1 connector to be configured. The LVDS1 Panel Resolution jumper settings are shown in Table 5-6.

DESCRIPTION (LVDS1)		
Pin 1-2	Pin 3-4	LVDS1
OFF	OFF	800 x 600 (18-bit)
ON	OFF	1024 x 768 (18-bit)
OFF	ON	1280 x 1024 (36-bit)
ON	ON	1400 x 1050 (36-bit)
DESCRIPTION (LVDS2)		
Pin 5-6	Pin 7-8	LVDS2
OFF	OFF	1024 X 768 (18-bit)
ON	OFF	1024 X 768 (24-bit)
OFF	ON	1280X1024 (36-bit)
ON	ON	1280X1024 (48-bit)

Table 5-6: LVDS Panel Resolution Jumper Settings

The LVDS Panel Resolution jumper location. is shown in Figure 5-8.

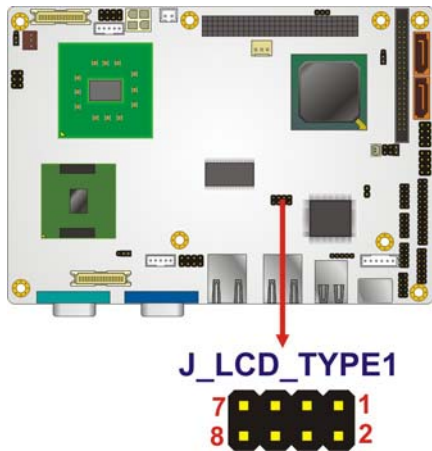

Figure 5-8:LVDS Panel Resolution Jumper Pinout Locations

5.5.6 LVDS Voltage Selection



WARNING:

Permanent damage to the screen and 3308440 may occur if the wrong voltage is selected with this jumper. Please refer to the user guide that came with the monitor to select the correct voltage.

Jumper Label: J_VLVDS1 and J_VLVDS2

Jumper Type: 3-pin header

Jumper Settings: See **Table 5-7**

Jumper Location: See **Figure 5-9**

The **LVDS Voltage Selection** jumpers allow the LVDS screen voltages to be set. J_VLVDS1 sets the voltage connected to LVDS1 and J_VLVDS2 sets the voltage for the screen connected to LVDS2. The **LVDS Voltage Selection** jumper settings are shown in **Table 5-7**.

LCD Voltage Select	Description	
Short 1-2	+3.3V LVDS	
Short 2-3	+5V LVDS	Default

Table 5-7: LVDS Voltage Selection Jumper Settings

The LVDS Voltage Selection jumper location. is shown in **Figure 5-9**.

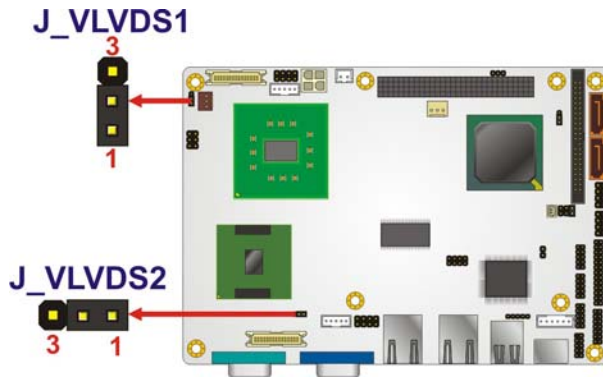

Figure 5-9: LVDS Voltage Selection Jumper Pinout Locations

5.5.7 PCI-104 Voltage Setup

Jumper Label:	JP2
Jumper Type:	3-pin header
Jumper Settings:	See Table 5-7
Jumper Location:	See Figure 5-9

The **PCI-104 Voltage Setup** jumper allows the LVDS screen voltage to be set. The **PCI-104 Voltage Setup** jumper settings are shown in Table 5-7.

PCI-104 Voltage Setup	Description	
Short 1-2	+5V	
Short 2-3	+3.3V	Default

Table 5-8: PCI-104 Voltage Setup Jumper Settings

The PCI-104 Voltage Setup jumper location. is shown in **Figure 5-9**.

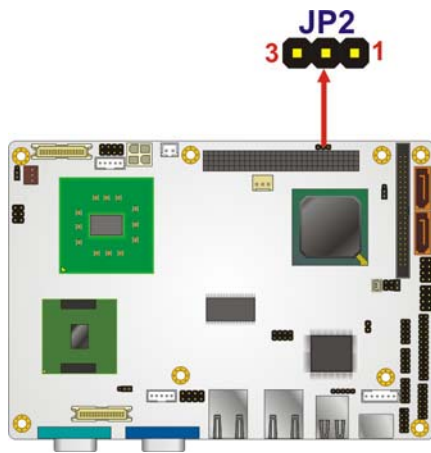

Figure 5-10: PCI-104 Voltage Setup Jumper Pinout Locations

5.6 Chassis Installation

5.6.1 Airflow



WARNING:

Airflow is critical to the cooling of the CPU and other onboard components. The chassis in which the 3308440 must have air vents to allow cool air to move into the system and hot air to move out.

The 3308440 card must be installed in a chassis with ventilation holes on the sides allowing airflow to travel through the heat sink surface. In a system with an individual power supply unit, the cooling fan of a power supply can also help generate airflow through the board surface.

5.6.2 Motherboard Installation

To install the 3308440 motherboard into the chassis please refer to the reference material that came with the chassis.

5.7 Internal Peripheral Device Connections

5.7.1 Peripheral Device Cables

The cables listed in **Table 5-9** are shipped with the 3308440.

Quantity	Type
1	Keyboard and Mouse cable
2	SATA drive cable
1	Power cable
1	RS-232 cable

Table 5-9: Provided Cables

Some optional items that can be purchased separately and installed on the 3308440 include:

- Dual port USB cable
- Parallel port cable
- RS-232/422/485 cable
- ATX power cable
- HDTV out cable
- 44-pin 2.5" IDE cable
- 44-pin 2.5"/3.5" IDE cable
- SATA power cable
- 5.1 channel audio kit
- 7.1 channel audio kit

5.7.2 AT Power Connection

Follow the instructions below to connect the 3308440 to an AT power supply.



WARNING:

Disconnect the power supply power cord from its AC power source to prevent a sudden power surge to the 3308440.

Step 1: **Locate the power cable.** The power cable is shown in the packing list in **Chapter 3**.

Step 2: **Connect the Power Cable to the Motherboard.** Connect the 4-pin (2x2) Molex type power cable connector to the AT power connector on the motherboard. See Figure 5-11.

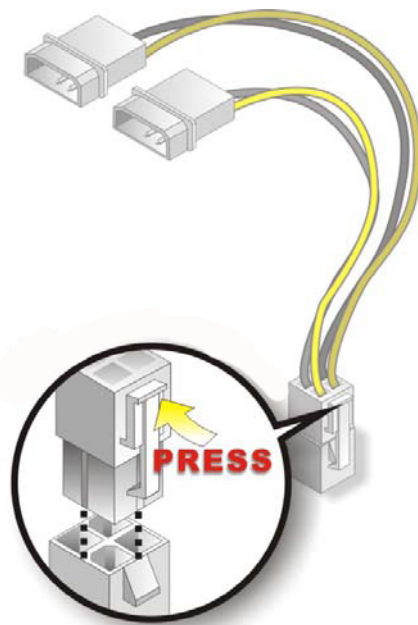

Figure 5-11: Power Cable to Motherboard Connection

Step 3: **Connect Power Cable to Power Supply.** Connect one of the 4-pin (1x4) Molex

Power cable connectors to an AT power supply. See Figure 5-12.

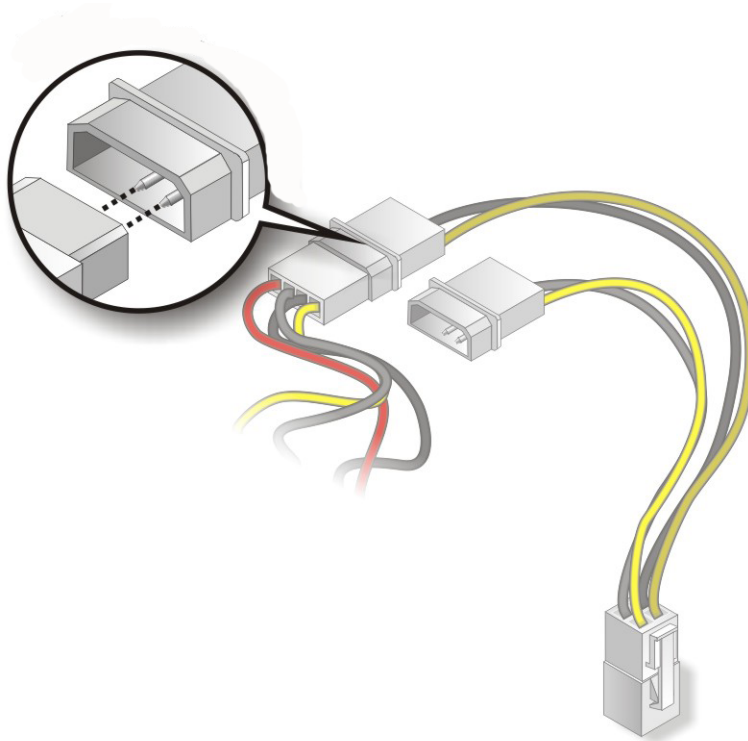

Figure 5-12: Connect Power Cable to Power Supply

5.7.3 5.1 Channel Audio Kit Installation

The optional 5.1 channel audio kit connects to the 10-pin audio connector on the 3308440. The audio kit consists of three audio jacks. One audio jack, Mic In, connects

to a microphone. The remaining two audio jacks, Line-In and Line-Out, connect to two speakers. To install the audio kit, please refer to the steps below:

Step 1: Connect the audio kit cable. The audio kit is shipped with a cable that connects the audio kit to the 3308440. Connect the cable to the connector on the back of the audio kit. Make sure the pins are properly aligned (i.e. pin 1 connects to pin 1).

Step 2: Locate the audio connector. The location of the 10-pin audio connector is shown in **Chapter 3**.

Step 3: Align pin 1. Align pin 1 on the on-board connector with pin 1 on the audio kit cable connector. Pin 1 on the audio kit cable connector is indicated with a white dot. See **Error! Reference source not found.**

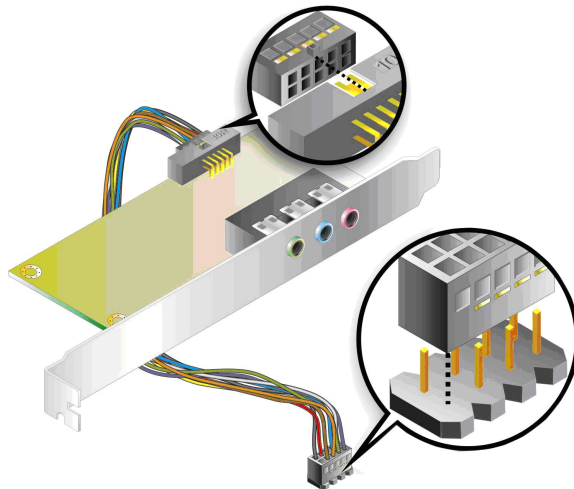

Figure 5-13: 5.1 Channel Audio Kit

Step 4: Mount the audio kit onto the chassis. Once the audio kit is connected to the NOVA-9452, secure the audio kit bracket to the system chassis.

Step 5: Connect the audio devices. Connect one speaker to the line-in audio jack, one speaker to the line-out audio jack and a microphone to the mic-in audio jack.

Step 6: Install the driver. If the 5.1 channel audio kit is used, the ALC655 Realtek codec driver must be installed. Refer to **Chapter 7** for driver installation instructions.

5.7.4 7.1 Channel Audio Kit Installation

The optional 7.1 channel audio kit connects to the 10-pin audio connector on the 3308440. The audio kit consists of five audio jacks. One audio jack, Mic In, connects to a microphone. The remaining four audio jacks, Line-In, Front-Out, Rear-Out, and Center Subwoofer, connect to speakers. To install the audio kit, please refer to the steps below:

Step 1: Connect the audio kit cable. The audio kit is shipped with a cable that connects the audio kit to the 3308440. Connect the cable to the connector on the back of the audio kit. Make sure the pins are properly aligned (i.e. pin 1 connects to pin 1).

Step 2: Locate the audio connector. The location of the 10-pin audio connector is shown in **Chapter 3**.

Step 3: Align pin 1. Align pin 1 on the on-board connector with pin 1 on the audio kit cable connector. Pin 1 on the audio kit cable connector is indicated with a white dot. See **Figure 5-14**.

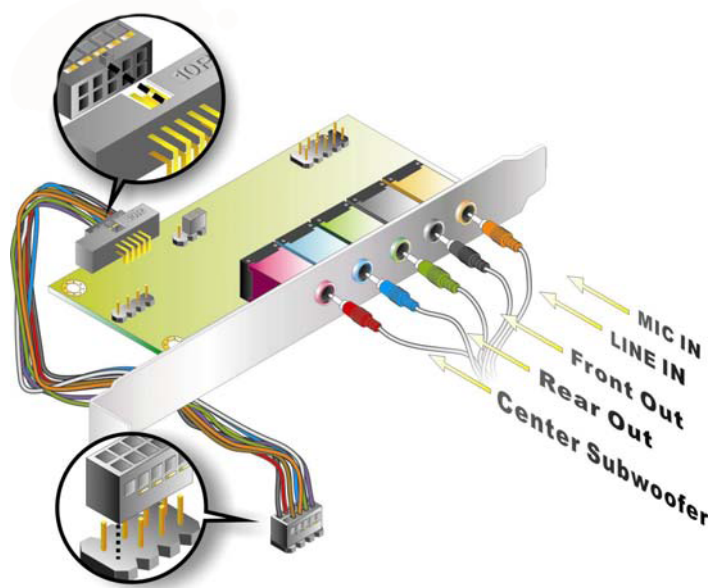

Figure 5-14: 7.1 Channel Audio Kit

Step 4: Mount the audio kit onto the chassis. Once the audio kit is connected to the NOVA-9452, secure the audio kit bracket to the system chassis.

Step 5: Connect the audio devices. Connect one speaker to the line-in audio jack, one speaker to the line-out audio jack and a microphone to the mic-in audio jack.

Step 6: Install the driver. If the 7.1 channel audio kit is used, the ALC883 Realtek codec driver must be installed. Refer to **Chapter 7** for driver installation instructions.

5.7.5 ATA Flat Cable Connection

The ATA 66/100 flat cable connects to the 3308440 to one or two IDE devices. To connect an IDE HDD to the 3308440 please follow the instructions below.

Step 1: Locate the IDE connector. The location/s of the IDE device connector/s is/are shown in **Chapter 3**.

Step 2: Insert the connector. Connect the IDE cable connector to the onboard connector. See Figure 5-15. A key on the front of the cable connector ensures it

can only be inserted in one direction.

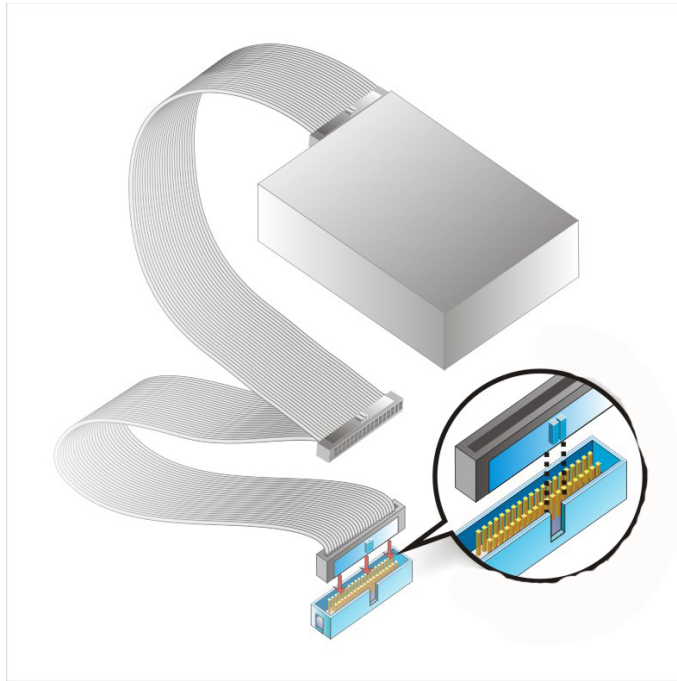

Figure 5-15: IDE Cable Connection

Step 3: **Connect the cable to an IDE device.** Connect the two connectors on the other side of the cable to one or two IDE devices. Make sure that pin 1 on the cable corresponds to pin 1 on the connector.

5.7.6 SATA Drive Connection

The 3308440 is shipped with two SATA drive cables and one SATA drive power cable. To connect the SATA drives to the connectors, please follow the steps below.

Step 1: **Locate the connectors.** The locations of the SATA drive connectors are shown in **Chapter 3**.

Step 2: **Insert the cable connector.** Press the clip on the connector at the end of the SATA cable and insert the cable connector into the onboard SATA drive connector. See **Figure 5-16**.

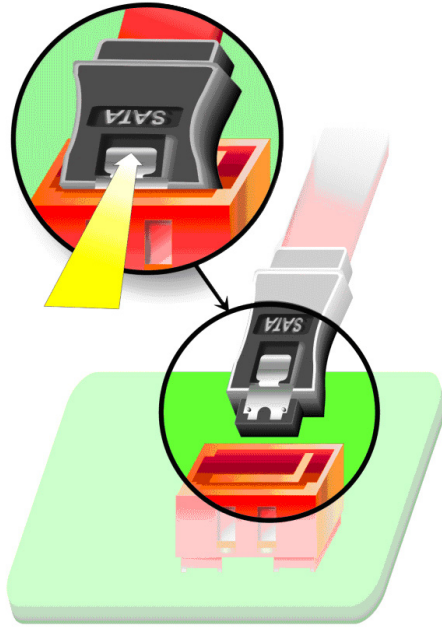

Figure 5-16: SATA Drive Cable Connection

Step 3: Connect the cable to the SATA disk. Connect the connector on the other end of the cable to the connector at the back of the SATA drive. See **Figure 5-17**.

Step 4: Connect the SATA power cable. Connect the SATA power connector to the back of the SATA drive. See **Figure 5-17**.



Figure 5-17: SATA Power Drive Connection

5.7.7 Single RS-232 Cable (w/o Bracket)

The single RS-232 cable consists of one serial port connector attached to a serial communications cable that is then attached to a D-sub 9 male connector. To install the single RS-232 cable, please follow the steps below.

Step 1: Locate the connector. The location of the RS-232 connector is shown in **Chapter 3**.

Step 2: Insert the cable connector. Insert the connector into the serial port box header. See Figure 5-18. A key on the front of the cable connectors ensures the connector can only be installed in one direction.

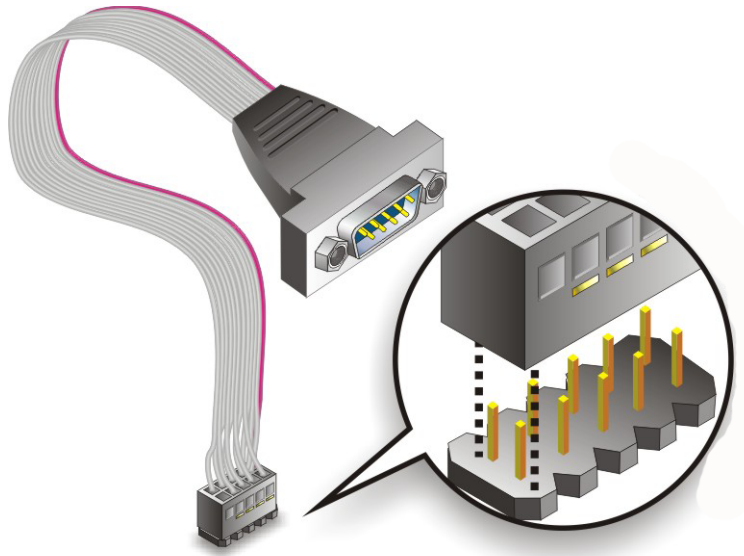

Figure 5-18: Single RS-232 Cable Installation

Step 3: Secure the bracket. The single RS-232 connector has two retention screws that must be secured to a chassis or bracket.

Step 4: Connect the serial device. Once the single RS-232 connector is connected to a chassis or bracket, a serial communications device can be connected to the system.

5.7.8 USB Cable (Dual Port without Bracket)

The 3308440 SBC is shipped with a dual port USB 2.0 cable. To connect the USB cable connector, please follow the steps below.

Step 1: Locate the connectors. The locations of the USB connectors are shown in Chapter 3.



WARNING:

If the USB pins are not properly aligned, the USB device can burn out.

Step 2: Align the connectors. The cable has two connectors. Correctly align pin 1 on

each cable connector with pin 1 on the 3308440 USB connector.

Step 3: Insert the cable connectors . Once the cable connectors are properly aligned with the USB connectors on the 3308440, connect the cable connectors to the on-board connectors. See Figure 5-19 .

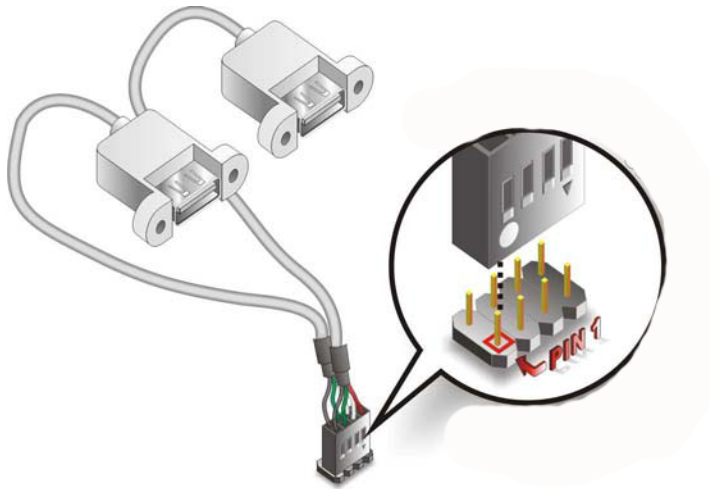

Figure 5-19: Dual USB Cable Connection

Step 4: **Attach the USB connectors to the chassis.** The USB 2.0 connectors each of two retention screw holes. To secure the connectors to the chassis please refer to the installation instructions that came with the chassis.

5.7.9 Parallel Port Cable without Bracket

The optional parallel port (LPT) cable respectively connects the on-board LPT 26-pin box header to an external LPT device (like a printer). The cable comprises a 26-pin female header, to be connected to the on-board LPT box-header, on one side and on the other side a standard external LPT connector. To connect the LPT cable, please follow the steps below.

Step 1: **Locate the connector.** The LPT connector location is shown in **Chapter 4**.

Step 2: **Align the connectors.** Correctly align pin 1 on the cable connector with pin 1 on the PCIE-9452 LPT box-header connector. See Figure 5-20.

Step 3: Insert the cable connectors Once the cable connector is properly aligned with the 26-pin box-header connector on the PCIE-9452, connect the cable connector to the on-board connector. See **Figure 5-20**.

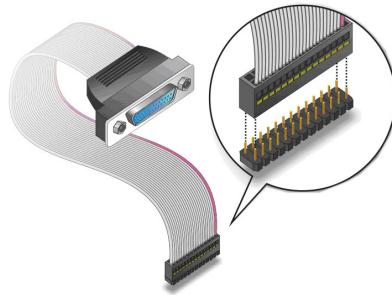

Figure 5-20: LPT Cable Connection

Step 4: Attach the LPT connector to the chassis. To secure the LPT interface connector to the chassis please refer to the installation instructions that came with the chassis.

Step 5: Connect LPT device. Once the LPT interface connector is connected to the chassis, the LPT device can be connected to the LPT interface connector. See **Figure 5-21**

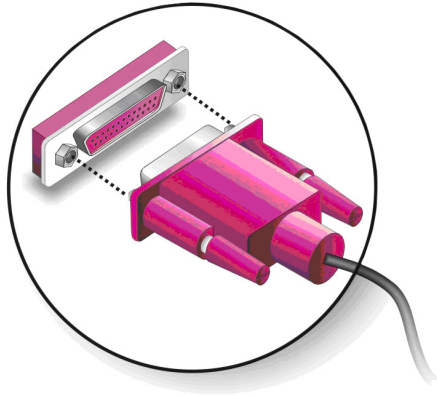

Figure 5-21: Connect the LPT Device

5.7.10 Dual RS-422/485 Cables

The 3308440 SBC is shipped with one RS-422/485 dual serial port connector cable. The dual serial port connector cable connects the serial port connectors on the cable to the RS-422/485 serial port connectors on the 3308440 SBC. Follow the steps below to connect the dual serial port connector cable.

- Step 1: Locate the serial port connector.** The location of the RS-422/485 serial port connector is shown in **Chapter 3**.
- Step 2: Align the connectors.** Correctly align pin 1 on the cable connector with pin 1 on the 3308440 COM2 serial port connector.
- Step 3: Insert the cable connectors** Once the cable connector is properly aligned with the COM2 serial port connector on the 3308440, connect the cable connector to the on-board connectors. See Figure 5-22.

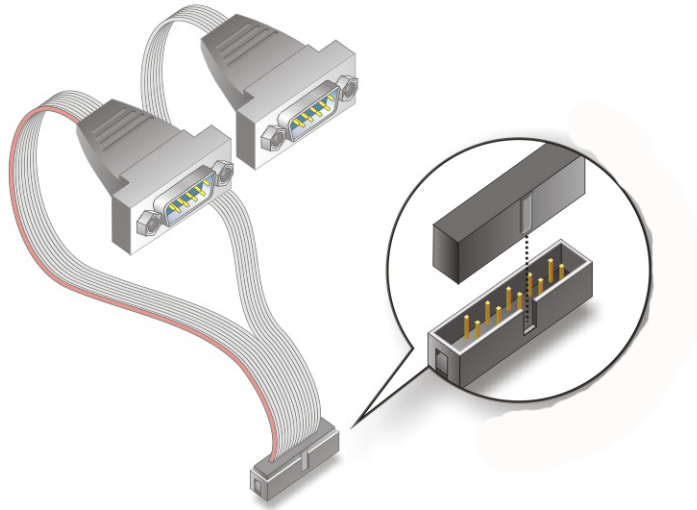

Figure 5-22: Dual Serial Port Connector Cable Connection

Step 4: Attach DB-9 serial port connectors to the chassis. The dual DB-9 serial port connectors can be inserted into dual preformed holes in the chassis. Once, inserted the DB-9 connectors should be secured to the chassis with retention screws.

5.8 External Peripheral Interface Connection

The following external peripheral devices can be connected to the external peripheral interface connectors.

- RJ-45 Ethernet cable connectors
- PS/2 devices
- Serial port devices
- USB devices
- VGA monitors

To install these devices, connect the corresponding cable connector from the actual device to the corresponding 3308440 SBC external peripheral interface connector making sure the pins are properly aligned.

5.8.1 LAN Connection (Single Connector)

There are two external RJ-45 LAN connectors. The RJ-45 connectors enable connection to an external network. To connect a LAN cable with an RJ-45 connector, please follow the instructions below.

Step 1: **Locate the RJ-45 connectors.** The locations of the USB connectors are shown in **Chapter 4**.

Step 2: **Align the connectors.** Align the RJ-45 connector on the LAN cable with one of the RJ-45 connectors on the 3308440 SBC. See **Figure 5-23**.

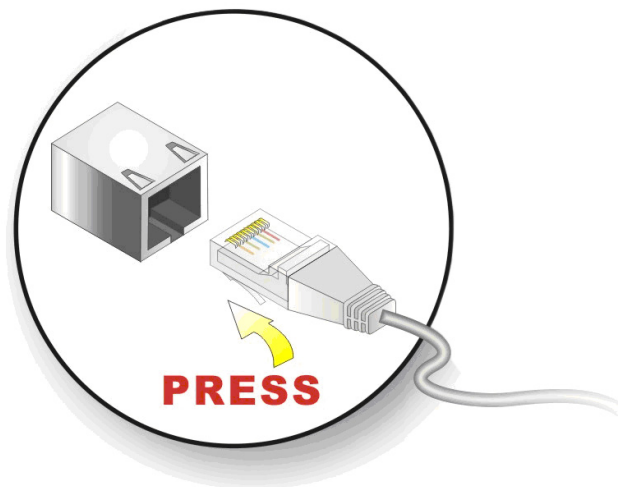

Figure 5-23: LAN Connection

Step 3: **Insert the LAN cable RJ-45 connector.** Once aligned, gently insert the LAN cable RJ-45 connector into the onboard RJ-45 connector.

5.8.2 PS/2 Y-Cable Connection

The 3308440 has a PS/2 connector on the external peripheral interface panel. The dual PS/2 connector is connected to the PS/2 Y-cable that came with the 3308440. One of the PS/2 cables is connected to a keyboard and the other to a mouse to the system. Follow the steps below to connect a keyboard and mouse to the 3308440.

Step 1: Locate the dual PS/2 connector. The location of the PS/2 connector is shown in **Chapter 3**.

Step 2: Insert the keyboard/mouse connector. Insert the PS/2 connector on the end of the PS/2 y-cable into the external PS/2 connector. See **Figure 5-24**.

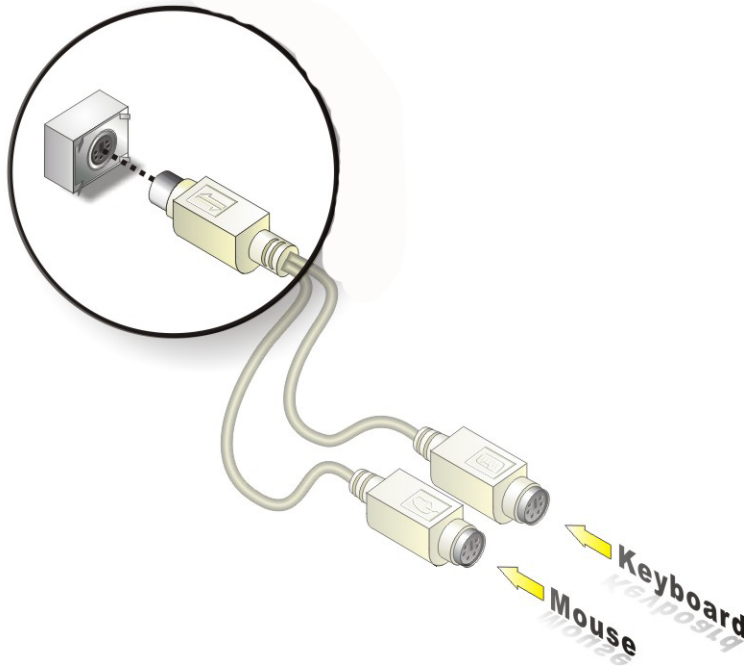

Figure 5-24: PS/2 Keyboard/Mouse Connector

Step 3: Connect the keyboard and mouse. Connect the keyboard and mouse to the appropriate connector. The keyboard and mouse connectors can be distinguished from each other by looking at the small graphic at the top of the connector.

5.8.3 Serial Device Connection

The 3308440 SBC has a single female DB-9 connector on the external peripheral interface panel for a serial device. Follow the steps below to connect a serial device to the 3308440.

Step 1: Locate the DB-9 connector. The location of the DB-9 connector is shown in

Chapter 3.

Step 2: Insert the serial connector. Insert the DB-9 connector of a serial device into the DB-9 connector on the external peripheral interface. See Figure 5-25.

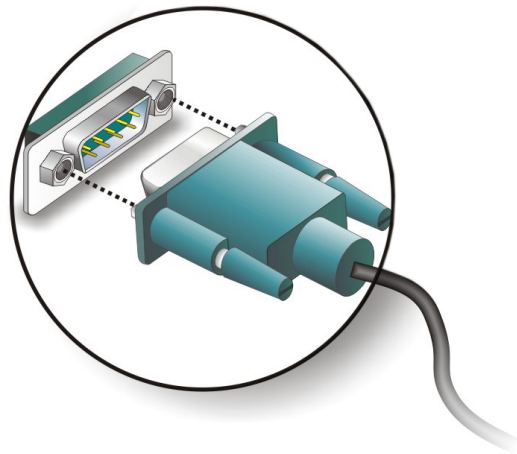

Figure 5-25: Serial Device Connector

Step 3: Secure the connector. Secure the serial device connector to the external interface by tightening the two retention screws on either side of the connector.

5.8.4 USB Connection (Dual Connector)

The external USB Series "A" receptacle connectors provide easier and quicker access to external USB devices. Follow the steps below to connect USB devices to the 3308440.

Step 1: Locate the USB Series "A" receptacle connectors. The location of the USB Series "A" receptacle connectors are shown in **Chapter 3**.

Step 2: Insert a USB Series "A" plug. Insert the USB Series "A" plug of a device into the USB Series "A" receptacle on the external peripheral interface. See **Figure**

5-26.

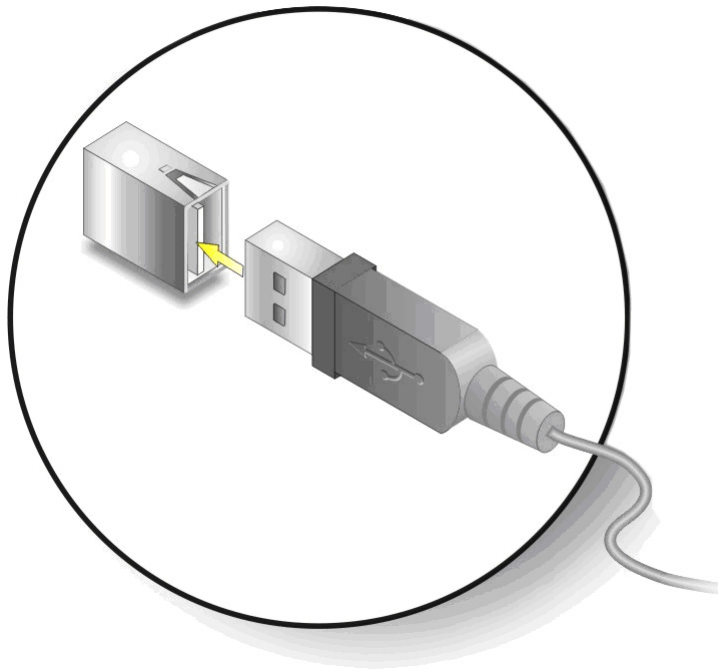

Figure 5-26: USB Connector

5.8.5 VGA Monitor Connection

The 3308440 EPIC SBC has a single female DB-15 connector on the external peripheral interface panel. The DB-15 connector is connected to a CRT or VGA monitor. To connect a monitor to the 3308440, please follow the instructions below.

- Step 1:** Locate the female DB-15 connector. The location of the female DB-15 connector is shown in Chapter 3.
- Step 2:** Align the VGA connector. Align the male DB-15 connector on the VGA screen cable with the female DB-15 connector on the external peripheral interface.
- Step 3:** Insert the VGA connector. Once the connectors are properly aligned with the insert the male connector from the VGA screen into the female connector on the 3308440. See Figure 5-27.

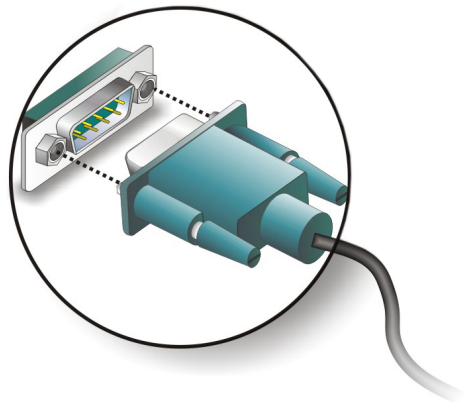

Figure 5-27: VGA Connector

Step 4: **Secure the connector.** Secure the DB-15 VGA connector from the VGA monitor to the external interface by tightening the two retention screws on either side of the connector.

Chapter

6

BIOS Screens

6.1 Introduction

A licensed copy of AMI BIOS is preprogrammed into the ROM BIOS. The BIOS setup program allows users to modify the basic system configuration. This chapter describes how to access the BIOS setup program and the configuration options that may be changed.

6.1.1 Starting Setup

The AMI BIOS is activated when the computer is turned on. The setup program can be activated in one of two ways.

1. Press the **DELETE** key as soon as the system is turned on or
2. Press the **DELETE** key when the “**Press Del to enter SETUP**” message appears on the screen. 0.

If the message disappears before the **DELETE** key is pressed, restart the computer and try again.

6.1.2 Using Setup

Use the arrow keys to highlight items, press **ENTER** to select, use the PageUp and PageDown keys to change entries, press **F1** for help and press **ESC** to quit. Navigation keys are shown in.

Key	Function
Up arrow	Move to previous item
Down arrow	Move to next item
Left arrow	Move to the item on the left hand side
Right arrow	Move to the item on the right hand side
Esc key	Main Menu – Quit and not save changes into CMOS Status Page Setup Menu and Option Page Setup Menu -- Exit current page and return to Main Menu
Page Up key	Increase the numeric value or make changes
Page Dn key	Decrease the numeric value or make changes

F1 key	General help, only for Status Page Setup Menu and Option Page Setup Menu
F2 /F3 key	Change color from total 16 colors. F2 to select color forward.
F10 key	Save all the CMOS changes, only for Main Menu

Table 6-1: BIOS Navigation Keys

6.1.3 Getting Help

When **F1** is pressed a small help window describing the appropriate keys to use and the possible selections for the highlighted item appears. To exit the Help Window press **Esc** or the **F1** key again.

6.1.4 Unable to Reboot After Configuration Changes

If the computer cannot boot after changes to the system configuration is made, CMOS defaults. Use the jumper described in **Chapter 5**.

6.1.5 BIOS Menu Bar

The **menu bar** on top of the BIOS screen has the following main items:

- **Main** Changes the basic system configuration.
- **Advanced** Changes the advanced system settings.
- **PCIPnP** Changes the advanced PCI/PnP Settings
- **Boot** Changes the system boot configuration.
- **Security** Sets User and Supervisor Passwords.
- **Chipset** Changes the chipset settings.
- **Power** Changes power management settings.
- **Exit** Selects exit options and loads default settings

The following sections completely describe the configuration options found in the menu items at the top of the BIOS screen and listed above.

6.2 Main

The **Main** BIOS menu (**BIOS Menu 1**) appears when the **BIOS Setup** program is entered.

The **Main** menu gives an overview of the basic system information.

```
BIOS SETUP UTILITY
Main  Advanced  PCIPnP  Boot  Security  Chipset  Power  Exit

System Overview
-----
AMIBIOS
Version      :08.00.15
Build Date   :08/28/08
ID           :B113MR17

Processor
Type         :Intel® Atom (TM) CPU N270 @ 1.60GHz
Speed        :1600MHz
Count        :1

System Memory
Size         :1016MB

System Time           [14:20:27]
System Date           [Tue 05/06/2008]

Use [ENTER], [TAB] or [SHIFT-TAB] to select a field.

Use [+] or [-] to configure system Time.

←→  Select Screen
↑↓  Select Item
+-  Change Field
Tab Select Field
F1  General Help
F10 Save and Exit
ESC Exit

v02.59 (C) Copyright 1985-2005, American Megatrends, Inc.
```

BIOS Menu 1: Main

→ System Overview

The **System Overview** lists a brief summary of different system components. The fields in

System Overview cannot be changed. The items shown in the system overview include:

- **AMI BIOS:** Displays auto-detected BIOS information
 - Version: Current BIOS version
 - Build Date: Date the current BIOS version was made
 - ID: Installed BIOS ID
- **Processor:** Displays auto-detected CPU specifications
 - Type: Names the currently installed processor
 - Speed: Lists the processor speed

- Count: The number of CPUs on the motherboard
- **System Memory:** Displays the auto-detected system memory.
- Size: Lists memory size

The **System Overview** field also has two user configurable fields:

→ **System Time [xx:xx:xx]**

Use the **System Time** option to set the system time. Manually enter the hours, minutes and seconds.

→ **System Date [xx/xx/xx]**

Use the **System Date** option to set the system date. Manually enter the day, month and year.

6.3 Advanced

Use the **Advanced** menu (**BIOS Menu 2**) to configure the CPU and peripheral devices through the following sub-menus:



WARNING:

Setting the wrong values in the sections below may cause the system to malfunction. Make sure that the settings made are compatible with the hardware.

- CPU Configuration (see Section 6.3.1)
- IDE Configuration (see Section 6.3.2)
- SuperIO Configuration (see Section 6.3.3)
- Hardware Health Configuration (see Section 6.3.4)
- Power Configuration (see Section 6.3.5)
- Remote Access Configuration (see Section 6.3.5.2)
- USB Configuration (see Section 6.3.7)

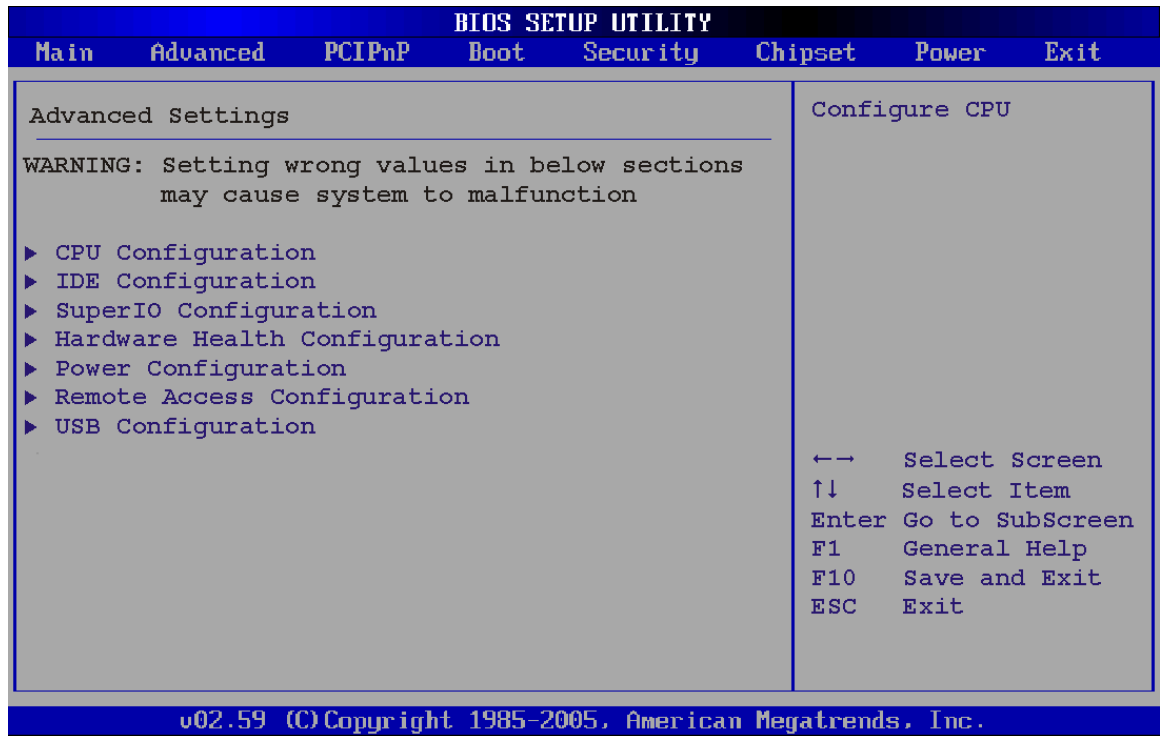

BIOS Menu 2: Advanced

6.3.1 CPU Configuration

Use the **CPU Configuration** menu (BIOS Menu 3) to view detailed CPU specifications and configure the CPU.

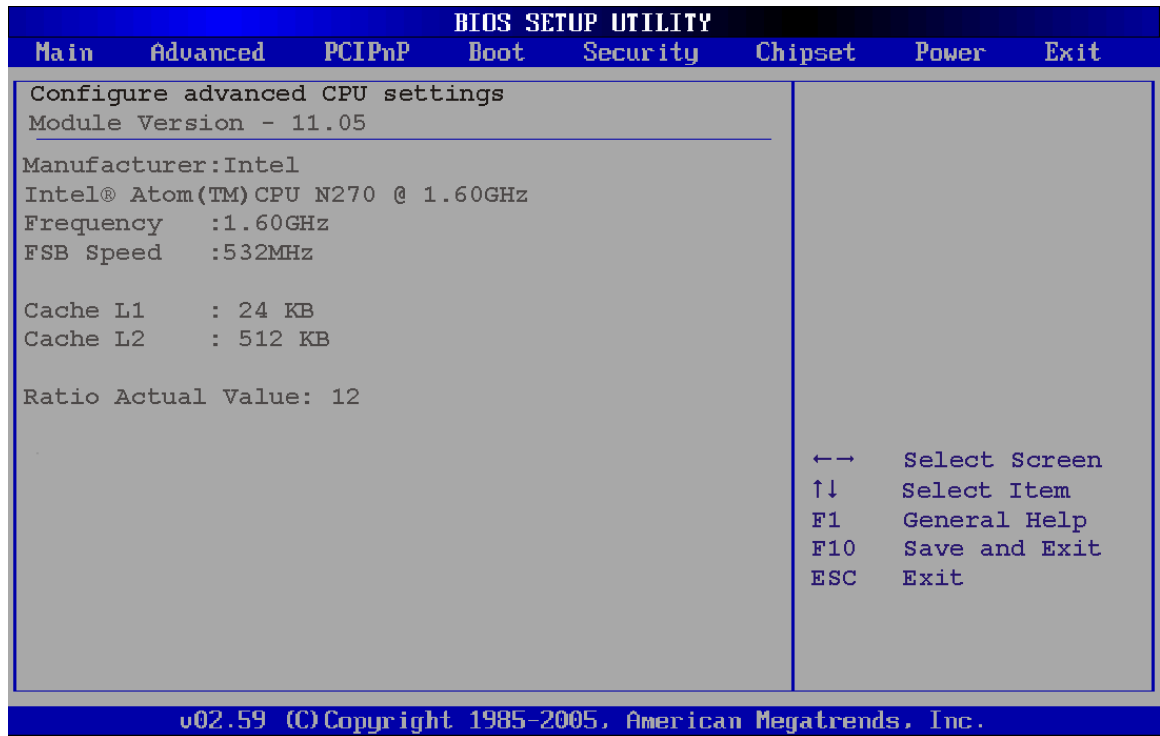

BIOS Menu 3: CPU Configuration

The CPU Configuration menu (BIOS Menu 3) lists the following CPU details:

- **Manufacturer:** Lists the name of the CPU manufacturer
- **Brand String:** Lists the brand name of the CPU being used
- **Frequency:** Lists the CPU processing speed
- **FSB Speed:** Lists the FSB speed
- **Cache L1:** Lists the CPU L1 cache size
- **Cache L2:** Lists the CPU L2 cache size

6.3.2 IDE Configuration

Use the **IDE Configuration** menu (**BIOS Menu 4**) to change and/or set the configuration of the IDE devices installed in the system.

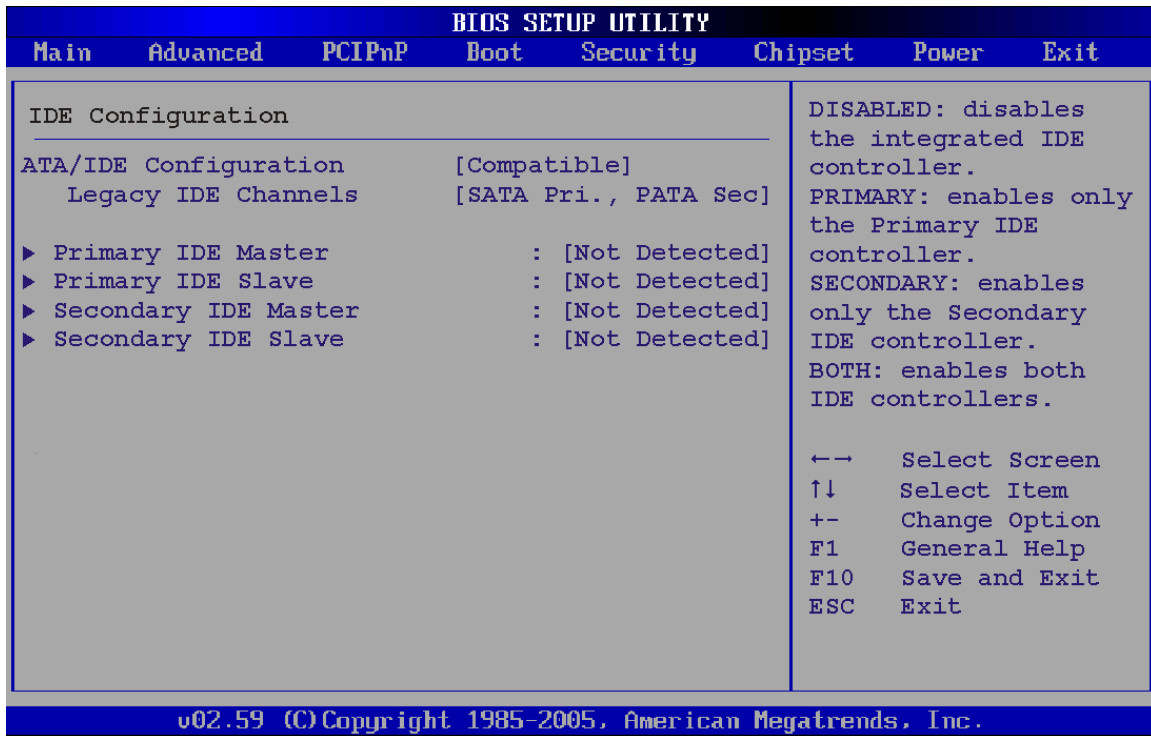

BIOS Menu 4: IDE Configuration

→ ATA/IDE Configurations [Compatible]

Use the **ATA/IDE Configurations** option to configure the ATA/IDE controller.

- **Disabled** Disables the on-board ATA/IDE controller.
- **Compatible** Configures the on-board ATA/IDE controller to be in compatible mode. In this mode, a SATA channel will replace one of the IDE channels. This mode supports up to 4 storage devices.
- **Enhanced** **DEFAULT** Configures the on-board ATA/IDE controller to be in Enhanced mode. In this mode, IDE channels and SATA channels are separated. This mode supports up to 6 storage devices. Some legacy OS do not support this mode.

→ **Legacy IDE Channels [PATA Pri, SATA Sec]**

- **SATA Only** Only the SATA drives are enabled.
- **SATA Pri, PATA Sec** **DEFAULT** The IDE drives are enabled on the Primary IDE channel. The SATA drives are enabled on the Secondary IDE channel.
- **PATA Only** The IDE drives are enabled on the primary and secondary IDE channels. SATA drives are disabled.

→ **IDE Master and IDE Slave**

When entering setup, BIOS auto detects the presence of IDE devices. BIOS displays the status of the auto detected IDE devices. The following IDE devices are detected and are shown in the **IDE Configuration** menu:

- Primary IDE Master
- Primary IDE Slave
- Secondary IDE Master
- Secondary IDE Slave

The **IDE Configuration** menu (**BIOS Menu 4**) allows changes to the configurations for the IDE devices installed in the system. If an IDE device is detected, and one of the above listed four BIOS configuration options are selected, the IDE configuration options shown in **Section 6.3.2.1** appear.

6.3.2.1 IDE Master, IDE Slave

Use the **IDE Master** and **IDE Slave** configuration menu to view both primary and secondary IDE device details and configure the IDE devices connected to the system.

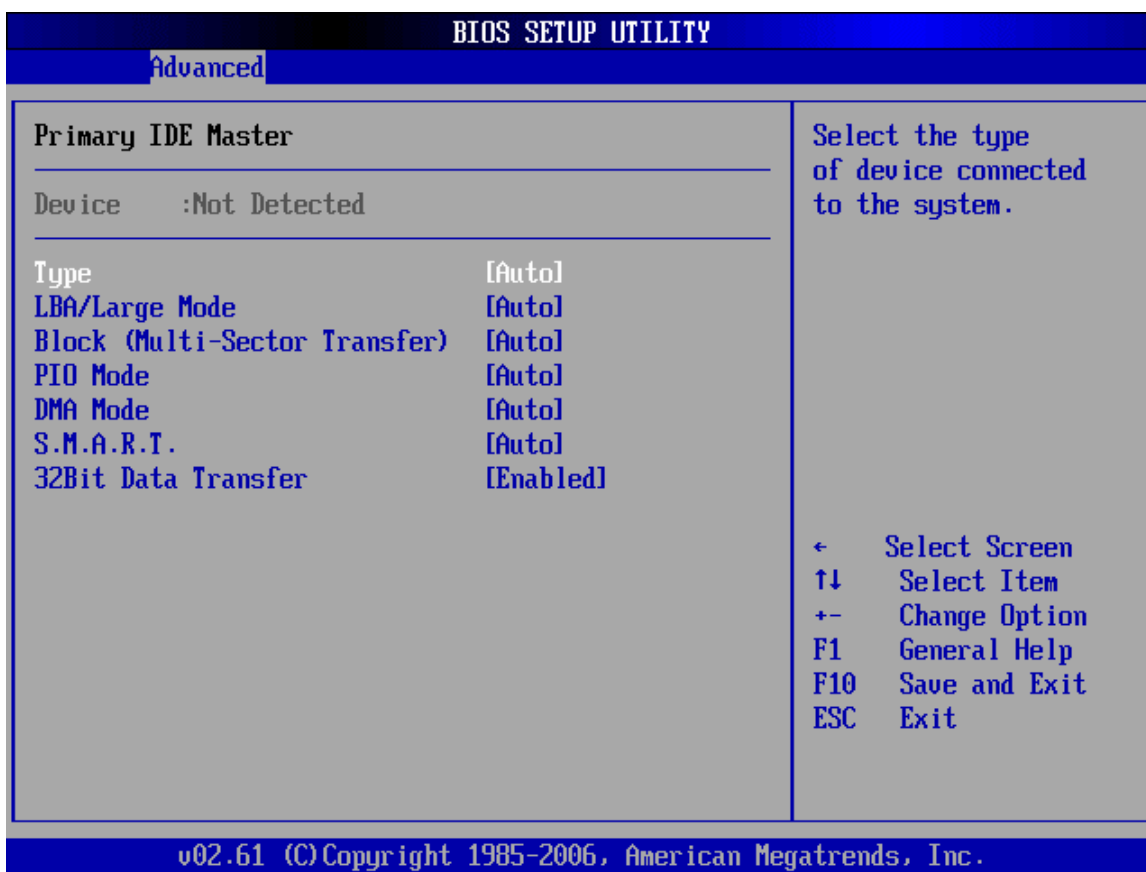

BIOS Menu 5: IDE Master and IDE Slave Configuration

→ Auto-Detected Drive Parameters

The “grayed-out” items in the left frame are IDE disk drive parameters automatically detected from the firmware of the selected IDE disk drive. The drive parameters are listed as follows:

- **Device:** Lists the device type (e.g. hard disk, CD-ROM etc.)
- **Type:** Indicates the type of devices a user can manually select
- **Vendor:** Lists the device manufacturer
- **Size:** List the storage capacity of the device.
- **LBA Mode:** Indicates whether the LBA (Logical Block Addressing) is a method of addressing data on a disk drive is supported or not.
- **Block Mode:** Block mode boosts IDE drive performance by increasing the amount of data transferred. Only 512 bytes of data can be transferred per

interrupt if block mode is not used. Block mode allows transfers of up to 64 KB per interrupt.

- **PIO Mode:** Indicates the PIO mode of the installed device.
- **Async DMA:** Indicates the highest Asynchronous DMA Mode that is supported.
- **Ultra DMA:** Indicates the highest Synchronous DMA Mode that is supported.
- **S.M.A.R.T.:** Indicates whether or not the Self-Monitoring Analysis and Reporting Technology protocol is supported.
- **32Bit Data Transfer:** Enables 32-bit data transfer.

→ **Type [Auto]**

Use the **Type** BIOS option select the type of device the AMIBIOS attempts to boot from after the Power-On Self-Test (POST) is complete.

- **Not Installed** BIOS is prevented from searching for an IDE disk drive on the specified channel.
- **Auto** **DEFAULT** The BIOS auto detects the IDE disk drive type attached to the specified channel. This setting should be used if an IDE hard disk drive is attached to the specified channel.
- **CD/DVD** The CD/DVD option specifies that an IDE CD-ROM drive is attached to the specified IDE channel. The BIOS does not attempt to search for other types of IDE disk drives on the specified channel.
- **ARMD** This option specifies an ATAPI Removable Media Device. These include, but are not limited to:

- **ZIP**

- **LS-120**

→ **LBA/Large Mode [Auto]**

Use the **LBA/Large Mode** option to disable or enable BIOS to auto detects LBA (Logical Block Addressing). LBA is a method of addressing data on a disk drive. In LBA mode, the maximum drive capacity is 137 GB.

→ **Disabled** BIOS is prevented from using the LBA mode control on the specified channel.

→ **Auto** **DEFAULT** BIOS auto detects the LBA mode control on the specified channel.

→ **Block (Multi Sector Transfer) [Auto]**

Use the **Block (Multi Sector Transfer)** to disable or enable BIOS to auto detect if the device supports multi-sector transfers.

→ **Disabled** BIOS is prevented from using Multi-Sector Transfer on the specified channel. The data to and from the device occurs one sector at a time.

→ **Auto** **DEFAULT** BIOS auto detects Multi-Sector Transfer support on the drive on the specified channel. If supported the data transfer to and from the device occurs multiple sectors at a time.

→ **PIO Mode [Auto]**

Use the **PIO Mode** option to select the IDE PIO (Programmable I/O) mode program timing cycles between the IDE drive and the programmable IDE controller. As the PIO mode increases, the cycle time decreases.

→ **Auto** **DEFAULT** BIOS auto detects the PIO mode. Use this value if the IDE disk drive support cannot be determined.

-
- 0 PIO mode 0 selected with a maximum transfer rate of 3.3MBps
 - 1 PIO mode 1 selected with a maximum transfer rate of 5.2MBps
 - 2 PIO mode 2 selected with a maximum transfer rate of 8.3MBps
 - 3 PIO mode 3 selected with a maximum transfer rate of 11.1MBps
 - 4 PIO mode 4 selected with a maximum transfer rate of 16.6MBps
(This setting generally works with all hard disk drives manufactured after 1999. For other disk drives, such as IDE CD-ROM drives, check the specifications of the drive.)

→ **DMA Mode [Auto]**

Use the **DMA Mode** BIOS selection to adjust the DMA mode options.

- **Auto** **DEFAULT** BIOS auto detects the DMA mode. Use this value if the IDE disk drive support cannot be determined.
- **SWDMA0** Single Word DMA mode 0 selected with a maximum data transfer rate of 2.1MBps
- **SWDMA1** Single Word DMA mode 1 selected with a maximum data transfer rate of 4.2MBps
- **SWDMA2** Single Word DMA mode 2 selected with a maximum data transfer rate of 8.3MBps
- **MWDMA0** Multi Word DMA mode 0 selected with a maximum data transfer rate of 4.2MBps
- **MWDMA1** Multi Word DMA mode 1 selected with a maximum data transfer rate of 13.3MBps
- **MWDMA2** Multi Word DMA mode 2 selected with a maximum data transfer rate of 16.6MBps

-
- **UDMA1** Ultra DMA mode 0 selected with a maximum data transfer rate of 16.6MBps
 - **UDMA1** Ultra DMA mode 1 selected with a maximum data transfer rate of 25MBps
 - **UDMA2** Ultra DMA mode 2 selected with a maximum data transfer rate of 33.3MBps
 - **UDMA3** Ultra DMA mode 3 selected with a maximum data transfer rate of 44MBps (To use this mode, it is required that an 80-conductor ATA cable is used.)
 - **UDMA4** Ultra DMA mode 4 selected with a maximum data transfer rate of 66.6MBps (To use this mode, it is required that an 80-conductor ATA cable is used.)
 - **UDMA5** Ultra DMA mode 5 selected with a maximum data transfer rate of 99.9MBps (To use this mode, it is required that an 80-conductor ATA cable is used.)

→ **S.M.A.R.T [Auto]**

Use the **S.M.A.R.T** option to auto-detect, disable or enable Self-Monitoring Analysis and Reporting Technology (SMART) on the drive on the specified channel. **S.M.A.R.T** predicts impending drive failures. The **S.M.A.R.T** BIOS option enables or disables this function.

- **Auto** **DEFAULT** BIOS auto detects HDD SMART support.
- **Disabled** Prevents BIOS from using the HDD SMART feature.
- **Enabled** Allows BIOS to use the HDD SMART feature

→ **32Bit Data Transfer [Enabled]**

Use the **32Bit Data Transfer** BIOS option to enable or disable 32-bit data transfers.

- ➔ **Disabled** Prevents the BIOS from using 32-bit data transfers.
- ➔ **Enabled** **DEFAULT** Allows BIOS to use 32-bit data transfers on supported hard disk drives.

6.3.3 Super IO Configuration

Use the **Super IO Configuration** menu (**BIOS Menu 6**) to set or change the configurations for the FDD controllers, parallel ports and serial ports.

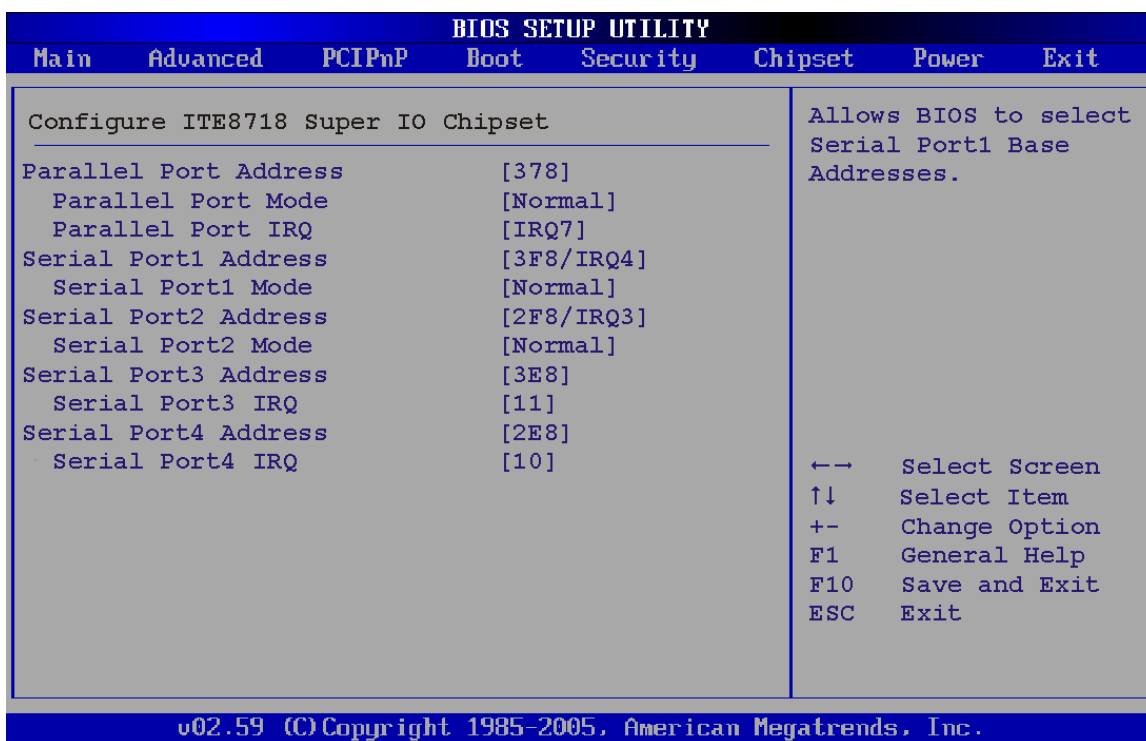

BIOS Menu 6: Super IO Configuration

➔ Parallel Port Address [Disabled]

Use the **Parallel Port Address** option to select the parallel port base address.

- ➔ **Disabled** **DEFAULT** No base address is assigned to the Parallel Port
- ➔ **378** Parallel Port I/O port address is 378

-
- **278** Parallel Port I/O port address is 278
 - **3BC** Parallel Port I/O port address is 3BC

→ **Parallel Port Mode [Normal]**

Use the **Parallel Port Mode** option to select the mode the parallel port operates in.

- **Normal** **DEFAULT** The normal parallel port mode is the standard mode for parallel port operation.
- **EPP** The parallel port operates in the enhanced parallel port mode (EPP). The EPP mode supports bi-directional communication between the system and the parallel port device and the transmission rates between the two are much faster than the Normal mode.
- **ECP+EPP** The parallel port operates in the extended capabilities port (ECP) mode. The ECP mode supports bi-directional communication between the system and the parallel port device and the transmission rates between the two are much faster than the Normal mode

The parallel port is also be compatible with EPP devices described above

→ **Parallel Port IRQ [IRQ7]**

Use the **Parallel Port IRQ** selection to set the parallel port interrupt address.

- **IRQ5** IRQ5 is assigned as the parallel port interrupt address
- **IRQ7** **DEFAULT** IRQ7 is assigned as the parallel port interrupt address

→ **Serial Port1 Address [3F8/IRQ4]**

Use the **Serial Port1 Address** option to select the Serial Port 1 base address.

- **Disabled** No base address is assigned to Serial Port 1
- **3F8/IRQ4** **DEFAULT** Serial Port 1 I/O port address is 3F8 and the interrupt address is IRQ4
- **3E8/IRQ4** Serial Port 1 I/O port address is 3E8 and the interrupt address is IRQ4
- **2E8/IRQ3** Serial Port 1 I/O port address is 2E8 and the interrupt address is IRQ3

→ **Serial Port1 Mode [Normal]**

Use the **Serial Port1 Mode** option to select the transmitting and receiving mode for the first serial port.

- **Normal** **DEFAULT** Serial Port 1 mode is normal
- **IrDA** Serial Port 1 mode is IrDA
- **ASK IR** Serial Port 1 mode is ASK IR

→ **Serial Port2 Address [2F8/IRQ3]**

Use the **Serial Port2 Address** option to select the Serial Port 2 base address.

- **Disabled** No base address is assigned to Serial Port 2
- **2F8/IRQ3** **DEFAULT** Serial Port 2 I/O port address is 3F8 and the interrupt address is IRQ3
- **3E8/IRQ4** Serial Port 2 I/O port address is 3E8 and the interrupt address is IRQ4

→ **2E8/IRQ3** Serial Port 2 I/O port address is 2E8 and the interrupt address is IRQ3

→ **Serial Port2 Mode [Normal]**

Use the **Serial Port2 Mode** option to select the Serial Port2 operational mode.

→ **Normal** **DEFAULT** Serial Port 2 mode is normal

→ **IrDA** Serial Port 2 mode is IrDA

→ **ASK IR** Serial Port 2 mode is ASK IR

→ **Serial Port3 Address [3E8]**

Use the **Serial Port3 Address** option to select the base addresses for serial port 3

→ **Disabled** No base address is assigned to serial port 3

→ **3E8** **DEFAULT** Serial port 3 I/O port address is 3E8

→ **2E8** Serial port 3 I/O port address is 2E8

→ **2F0** Serial port 3 I/O port address is 2F0

→ **2E0** Serial port 3 I/O port address is 2E0

→ **Serial Port3 IRQ [11]**

Use the **Serial Port3 IRQ** option to select the interrupt address for serial port 3.

→ **10** Serial port 3 IRQ address is 10

→ **11** **DEFAULT** Serial port 3 IRQ address is 11

→ **Serial Port4 Address [2E8]**

Use the **Serial Port4 IRQ** option to select the interrupt address for serial port 4.

-
- **Disabled** No base address is assigned to serial port 3
 - **3E8** Serial port 4 I/O port address is 3E8
 - **2E8** **DEFAULT** Serial port 4 I/O port address is 2E8
 - **2F0** Serial port 4 I/O port address is 2F0
 - **2E0** Serial port 4 I/O port address is 2E0

→ **Serial Port4 IRQ [10]**

Use the **Serial Port4 IRQ** option to select the interrupt address for serial port 4.

- **10** **DEFAULT** Serial port 4 IRQ address is 10
- **11** Serial port 4 IRQ address is 11

6.3.4 Hardware Health Configuration

The **Hardware Health Configuration** menu (**BIOS Menu 7**) shows the operating temperature, fan speeds and system voltages.

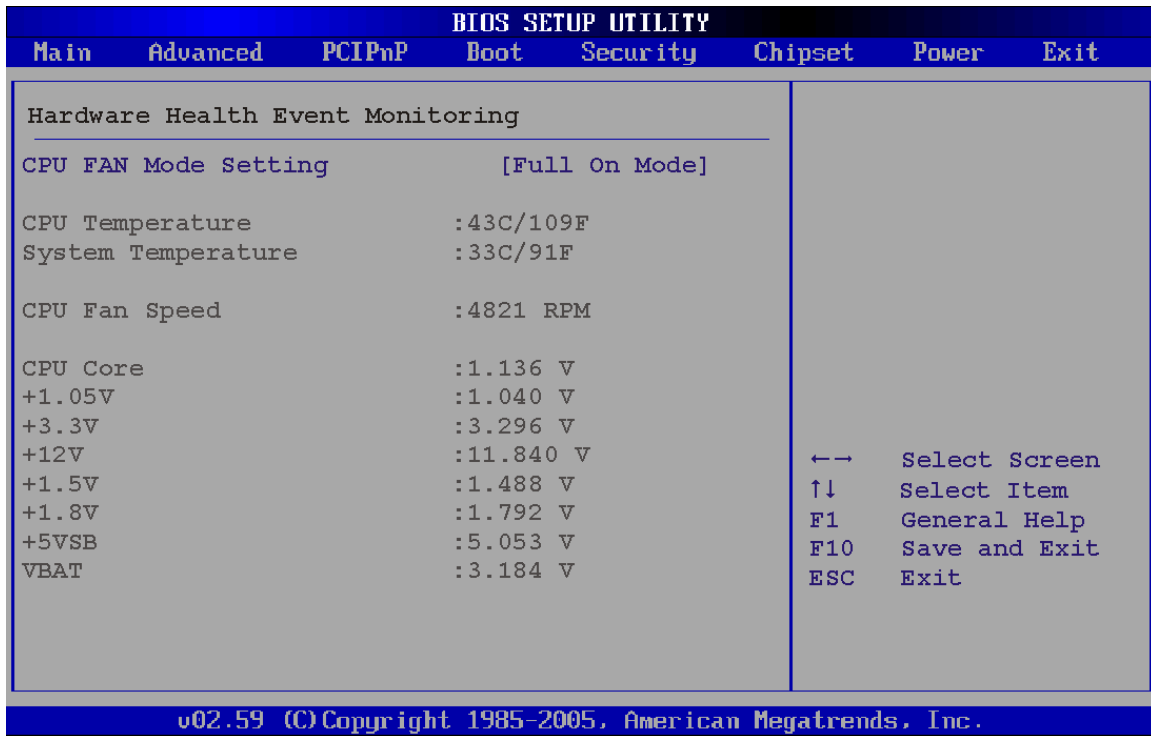

BIOS Menu 7: Hardware Health Configuration

→ CPU FAN Mode Setting [Full On Mode]

Use the **CPU FAN Mode Setting** option to configure the second fan.

- | | | | |
|---|------------------------|----------------|--|
| → | Full On Mode | DEFAULT | Fan is on all the time |
| → | Automatic mode | | Fan is off when the temperature is low enough. Parameters must be set by the user. |
| → | PWM Manual mode | | Pulse width modulation set manually |

When the **CPU FAN Mode Setting** option is in the **Automatic Mode**, the following parameters can be set.

- CPU Temp. Limit of OFF
- CPU Temp. Limit of Start

-
- CPU Fan Start PWM
 - Slope PWM 1

When the **CPU FAN Mode Setting** option is in the **PWM Manual Mode**, the following parameters can be set.

- CPU Fan PWM control

→ **CPU Temp. Limit of OFF [000]**



WARNING:

Setting this value too high may cause the fan to stop when the CPU is at a high temperature and therefore cause the system to be damaged.

The **CPU Temp. Limit of OFF** option can only be set if the **CPU FAN Mode Setting** option is set to **Automatic Mode**. Use the **CPU Temp. Limit of OFF** option to select the CPU temperature at which the cooling fan should automatically turn off. To select a value, select the **CPU Temp. Limit of OFF** option and enter a decimal number between 000 and 127. The temperature range is specified below.

- Minimum Value: 0°C
- Maximum Value: 127°C

→ **CPU Temp. Limit of Start [020]**



WARNING:

Setting this value too high may cause the fan to start only when the CPU is at a high temperature and therefore cause the system to be damaged.

The **CPU Temp. Limit of Start** option can only be set if the **CPU FAN Mode Setting** option is set to **Automatic Mode**. Use the **CPU Temp. Limit of Start** option to select the CPU temperature at which the cooling fan should automatically turn on. When the fan starts, it rotates using the starting pulse width modulation (PWM) specified in the **Fan 3 Start PWM** option below. To select a value, select the **CPU Temp. Limit of Start** option and enter a decimal number between 000 and 127. The temperature range is specified below.

- Minimum Value: 0°C
- Maximum Value: 127°C

→ **CPU Fan Start PWM [070]**

The **Fan 3 Start PWM** option can only be set if the **CPU FAN Mode Setting** option is set to **Automatic Mode**. Use the **Fan 3 Start PWM** option to select the PWM mode the fan starts to rotate with after the temperature specified in the **Temperature 3 Limit of Start** is exceeded. The Super I/O chipset supports 128 PWM modes. To select a value, select the **Fan 3 Start PWM** option and enter a decimal number between 000 and 127. The temperature range is specified below.

- PWM Minimum Mode: 0
- PWM Maximum Mode: 127

→ **Slope PWM [0.5 PWM]**

The **Slope PWM 1** option can only be set if the **CPU FAN Mode Setting** option is set to **Automatic Mode**. Use the **Slope PWM 1** option to select the linear rate at which the PWM mode increases with respect to an increase in temperature. A list of available options is shown below:

- 0 PWM
- 1 PWM
- 2 PWM
- 4 PWM
- 8 PWM

-
- 16 PWM
 - 32 PWM
 - 64 PWM

The following system parameters and values are shown. The system parameters that are monitored are:

- **System Temperatures:** The following system temperatures are monitored
 - CPU Temperature
 - System Temperature
- **Fan Speeds:** The CPU cooling fan speed is monitored.
 - CPU Fan Speed
- **Voltages:** The following system voltages are monitored
 - CPU Core
 - +1.05V
 - +3.30V
 - +12.0 V
 - +1.5V
 - +1.8V
 - 5VSB
 - VBAT

6.3.5 Power Configuration

The **Power Configuration** menu (BIOS Menu 8) configures the Advanced Configuration and Power Interface (ACPI) and Power Management (APM) options.

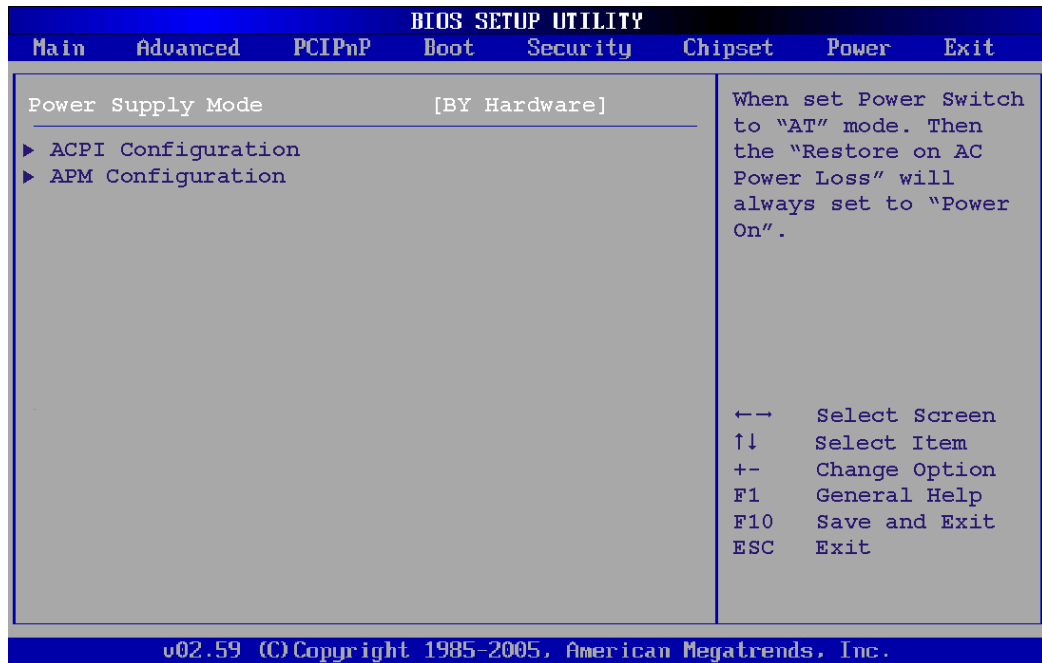

BIOS Menu 8: Power Configuration

6.3.5.1 ACPI configuration

The **ACPI Configuration** menu (**BIOS Menu 9**) configures the Advanced Configuration and Power Interface (ACPI).

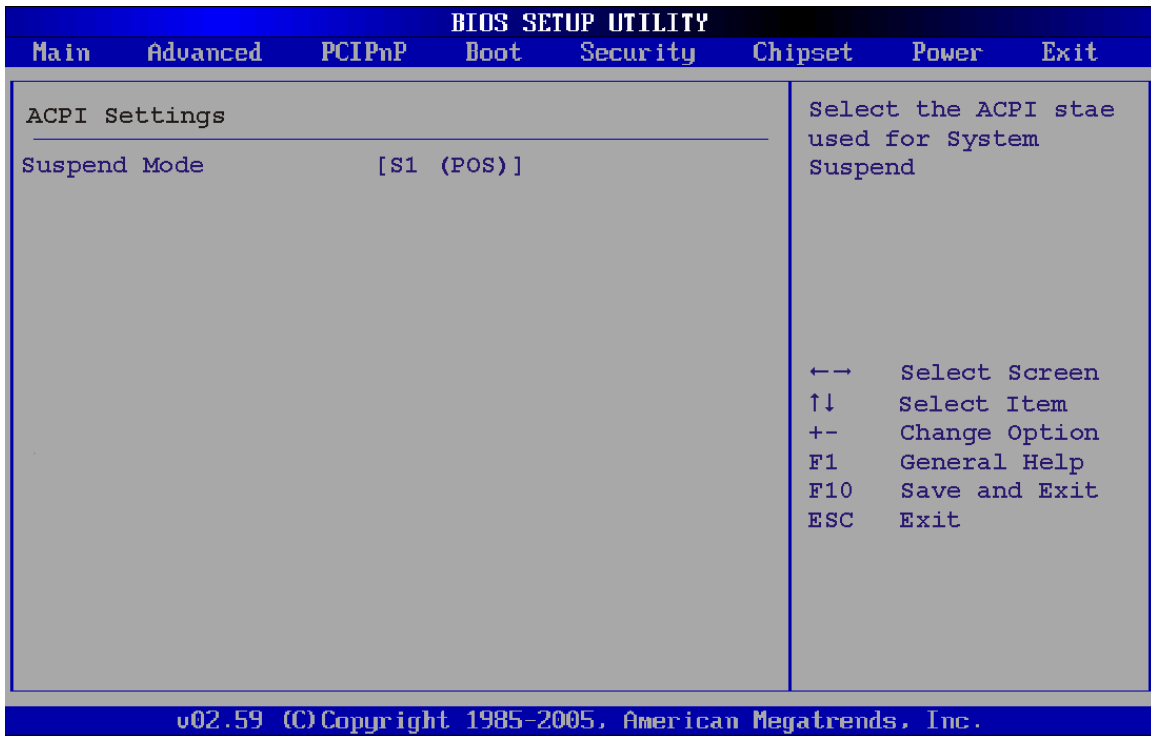

BIOS Menu 9: ACPI Configuration

→ Suspend Mode [S1(POS)]

Use the **Suspend Mode** BIOS option to specify the sleep state the system enters when it is not being used.

- **S1 (POS) DEFAULT** System appears off. The CPU is stopped; RAM is refreshed; the system is running in a low power mode.
- **S3 (STR)** System appears off. The CPU has no power; RAM is in slow refresh; the power supply is in a reduced power mode.

6.3.5.2 APM Configuration

The **APM Configuration** menu (**BIOS Menu 10**) allows the advanced power management options to be configured.

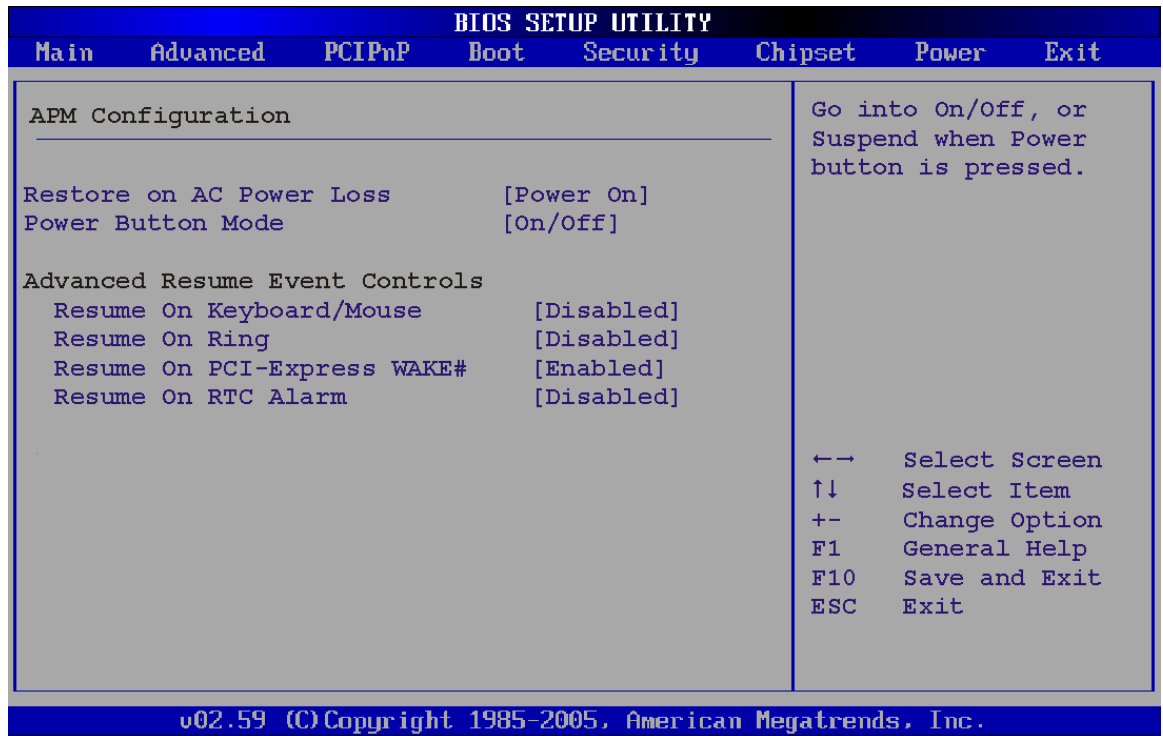

BIOS Menu 10: Advanced Power Management Configuration

→ Restore on AC Power Loss [Last State]

Use the **Restore on AC Power Loss** BIOS option to specify what state the system returns to if there is a sudden loss of power to the system.

- **Power Off** The system remains turned off
- **Power On** The system turns on
- **Last State** **DEFAULT** The system returns to its previous state. If it was on, it turns itself on. If it was off, it remains off.

→ Power Button Mode [On/Off]

Use the **Power Button Mode** BIOS to specify how the power button functions.

- **On/Off** **DEFAULT** When the power button is pressed the system is either

turned on or off

- **Suspend** When the power button is pressed the system goes into suspend mode

→ **Resume on Keyboard/Mouse [Disabled]**

Use the **Resume on Keyboard/Mouse** BIOS option to enable activity on either the keyboard or mouse to rouse the system from a suspend or standby state. That is, the system is roused when the mouse is moved or a button on the keyboard is pressed.

- **Disabled** (Default) Wake event not generated by activity on the keyboard or mouse
- **Enabled** Wake event generated by activity on the keyboard or mouse

→ **Resume on Ring [Disabled]**

Use the **Resume on Ring** BIOS option to enable activity on the RI (ring in) modem line to rouse the system from a suspend or standby state. That is, the system will be roused by an incoming call on a modem.

- **Disabled** **DEFAULT** Wake event not generated by an incoming call
- **Enabled** Wake event generated by an incoming call

→ **Resume on PCI-Express WAKE# [Enabled]**

Use the **Resume PCI-Express WAKE#** BIOS option to enable activity on the PCI-Express WAKE# signal to rouse the system from a suspend or standby state.

- **Disabled** Wake event not generated by PCI-Express WAKE# signal activity
- **Enabled** **DEFAULT** Wake event generated by PCI-Express WAKE# signal

activity

→ **Resume On RTC Alarm [Disabled]**

Use the **Resume On RTC Alarm** option to specify the time the system should be roused from a suspended state.

→ **Disabled** **DEFAULT** The real time clock (RTC) cannot generate a wake event

→ **Enabled** If selected, the following appears with values that can be selected:

→ **RTC Alarm Date (Days)**

→ **System Time**

After setting the alarm, the computer turns itself on from a suspend state when the alarm goes off.

6.3.6 Remote Configuration

Use the **Remote Access Configuration** menu (**BIOS Menu 11**) to configure remote access parameters. The **Remote Access Configuration** is an AMIBIOS feature and allows a remote host running a terminal program to display and configure the BIOS settings.

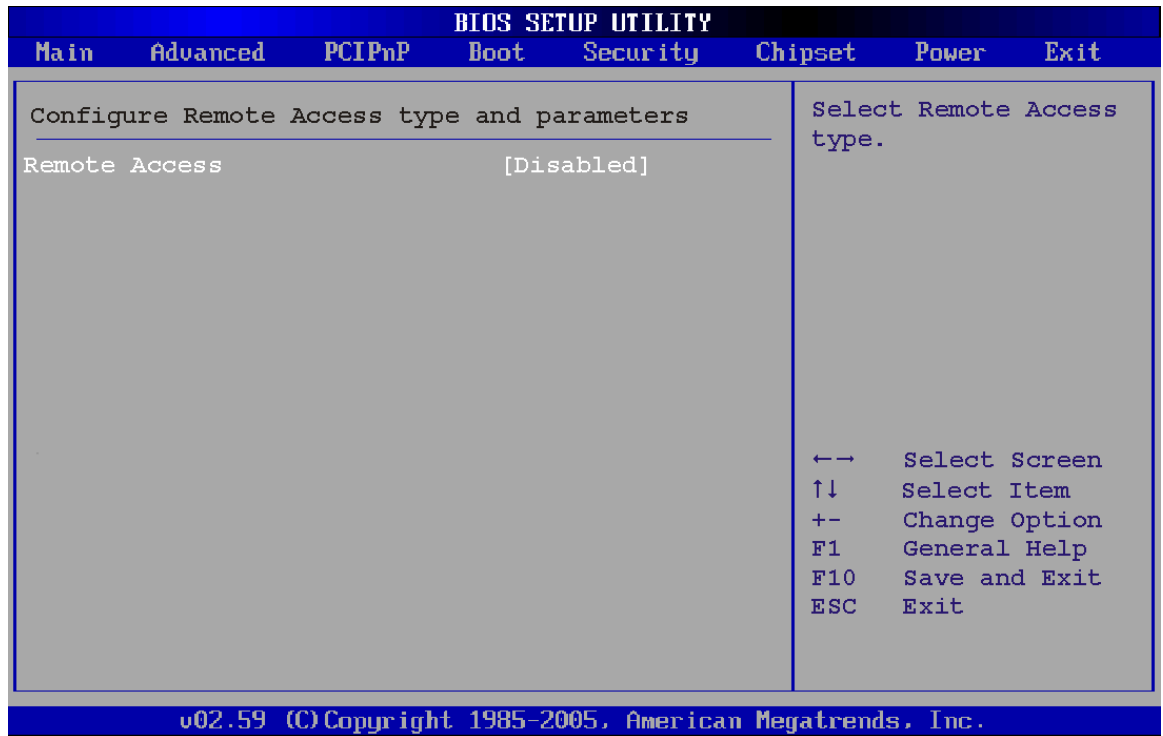

BIOS Menu 11: Remote Access Configuration [Advanced]

→ Remote Access [Disabled]

Use the **Remote Access** option to enable or disable access to the remote functionalities of the system.

- **Disabled** **DEFAULT** Remote access is disabled.
- **Enabled** Remote access configuration options shown below appear:
 - **Serial Port Number**
 - **Serial Port Mode**
 - **Flow Control**
 - **Redirection after BIOS POST**

→ **Terminal Type**

→ **VT-UTF8 Combo Key Support**

These configuration options are discussed below.

→ **Serial Port Number [COM1]**

Use the **Serial Port Number** option allows to select the serial port used for remote access.

→ **COM1** **DEFAULT** System is remotely accessed through COM1

→ **COM2** System is remotely accessed through COM2

NOTE: Make sure the selected COM port is enabled through the Super I/O configuration menu.

→ **Base Address, IRQ [2F8h,3]**

The **Base Address, IRQ** option cannot be configured and only shows the interrupt address of the serial port listed above.

→ **Serial Port Mode [115200 8,n,1]**

Use the **Serial Port Mode** option to select baud rate through which the console redirection is made. The following configuration options are available

- 115200 8,n,1 **DEFAULT**
- 57600 8,n,1
- 38400 8,n,1
- 19200 8,n,1
- 09600 8,n,1



NOTE:

Identical baud rate setting must be set on the host (a management computer running a terminal software) and the slave

→ **Flow Control [None]**

Use the **Flow Control** option to report the flow control method for the console redirection application.

- **None** **DEFAULT** No control flow,
- **Hardware** Hardware is set as the console redirection
- **Software** Software is set as the console redirection

→ **Redirection After BIOS POST [Always]**

Use the **Redirection After BIOS POST** option to specify when console redirection should occur.

- **Disabled** The console is not redirected after POST
- **Boot Loader** Redirection is active during POST and during Boot Loader
- **Always** **DEFAULT** Redirection is always active (Some OSes may not work if set to Always)

→ **Terminal Type [ANSI]**

Use the **Terminal Type** BIOS option to specify the remote terminal type.

- **ANSI** **DEFAULT** The target terminal type is ANSI
- **VT100** The target terminal type is VT100
- **VT-UTF8** The target terminal type is VT-UTF8

→ **VT-UTF8 Combo Key Support [Disabled]**

Use the **VT-UFT8 Combo Key Support** option to enable additional keys that are not provided by VT100 for the PC 101 keyboard.

The VT100 Terminal Definition is the standard convention used to configure and conduct emergency management tasks with UNIX-based servers. VT100 does not support all keys on the standard PC 101-key layout, however. The VT-UTF8 convention makes available additional keys that are not provided by VT100 for the PC 101 keyboard.

- **Disabled** **DEFAULT** Disables the VT-UTF8 terminal keys
- **Enabled** Enables the VT-UTF8 combination key. Support for ANSI/VT100 terminals

→ **Sredir Memory Display Delay [Disabled]**

Use the **Sredir Memory Display Delay** option to select the delay before memory information is displayed. Configuration options are listed below

- No Delay **DEFAULT**
- Delay 1 sec
- Delay 2 sec
- Delay 4 sec

6.3.7 USB Configuration

Use the **USB Configuration** menu (**BIOS Menu 12**) to read USB configuration information and configure the USB settings.

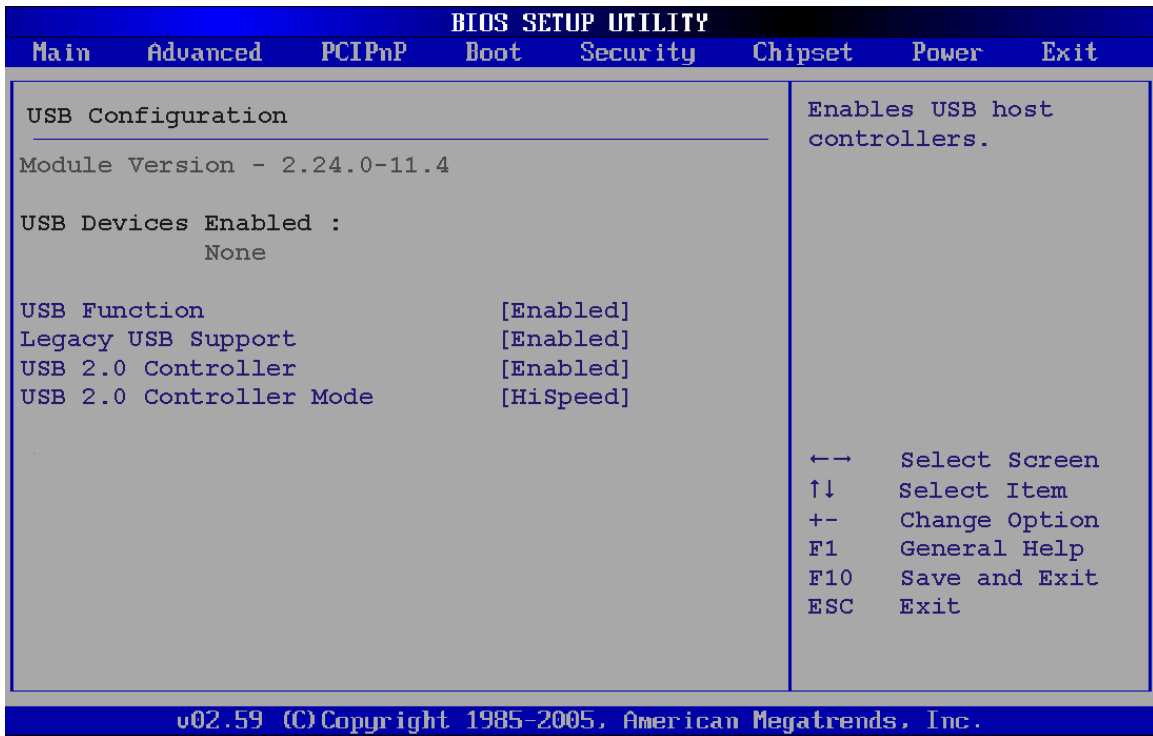

BIOS Menu 12: USB Configuration

→ USB Functions [Enabled]

Use the **USB Function** option to enable or disable the USB controllers.

- **Disabled** USB controllers are enabled
- **Enabled** **DEFAULT** USB controllers are disabled

→ USB 2.0 Controller [Enabled]

The **USB 2.0 Controller** BIOS option enables or disables the USB 2.0 controller

- **Disabled** USB function disabled
- **Enabled** **DEFAULT** USB function enabled

→ USB2.0 Controller Mode [HiSpeed]

The **USB2.0 Controller Mode** BIOS option sets the speed of the USB2.0 controller.

- **FullSpeed** The controller is capable of operating at full speed
12 Mb/s
- **HiSpeed** **DEFAULT** The controller is capable of operating at high speed
480 Mb/s

→ **Legacy USB Support [Enabled]**

Use the **Legacy USB Support** BIOS option to enable USB mouse and USB keyboard support.

Normally if this option is not enabled, any attached USB mouse or USB keyboard does not become available until a USB compatible operating system is fully booted with all USB drivers loaded. When this option is enabled, any attached USB mouse or USB keyboard can control the system even when there is no USB driver loaded onto the system.

- **Disabled** Legacy USB support disabled
- **Enabled** **DEFAULT** Legacy USB support enabled
- **Auto** Legacy USB support disabled if no USB devices are
connected

6.4 PCI/PnP

Use the PCI/PnP menu (BIOS Menu 13) to configure advanced PCI and PnP settings.



WARNING:

Setting wrong values for the BIOS selections in the PCIPnP BIOS menu may cause the system to malfunction.

BIOS SETUP UTILITY							
Main	Advanced	PCIPnP	Boot	Security	Chipset	Power	Exit
Advanced PCI/PnP Settings						Available: Specified IRQ is available to be use by PCI/PnP devices.	
WARNING: Setting wrong values in below sections may cause system to malfunction						Reserved: Specified IRQ is reserved for use by legacy ISA devices.	
IRQ3				[Reserved]			
IRQ4				[Reserved]			
IRQ5				[Available]			
IRQ7				[Reserved]			
IRQ9				[Available]			
IRQ10				[Available]			
IRQ11				[Available]			
IRQ14				[Available]			
IRQ15				[Available]			
DMA Channel 0				[Available]			←→ Select Screen
DMA Channel 1				[Available]			↑↓ Select Item
DMA Channel 3				[Available]			+ - Change Option
DMA Channel 5				[Available]			F1 General Help
DMA Channel 6				[Available]			F10 Save and Exit
DMA Channel 7				[Available]			ESC Exit
v02.59 (C) Copyright 1985-2005, American Megatrends, Inc.							

BIOS Menu 13: PCI/PnP Configuration

→ IRQ# [Available]

Use the **IRQ#** address to specify what IRQs can be assigned to a particular peripheral device.

→ **Available** **DEFAULT** The specified IRQ is available to be used by PCI/PnP devices

→ **Reserved** The specified IRQ is reserved for use by Legacy ISA devices

Available IRQ addresses are:

- IRQ3
- IRQ4
- IRQ5
- IRQ7

-
- IRQ9
 - IRQ10
 - IRQ 11
 - IRQ 14
 - IRQ 15

→ **DMA Channel# [Available]**

Use the **DMA Channel#** option to assign a specific DMA channel to a particular PCI/PnP device.

- **Available** **DEFAULT** The specified DMA is available to be used by PCI/PnP devices
- **Reserved** The specified DMA is reserved for use by Legacy ISA devices

Available DMA Channels are:

- DM Channel 0
- DM Channel 1
- DM Channel 3
- DM Channel 5
- DM Channel 6
- DM Channel 7

→ **Reserved Memory Size [Disabled]**

Use the **Reserved Memory Size** BIOS option to specify the amount of memory that should be reserved for legacy ISA devices.

- **Disabled** **DEFAULT** No memory block reserved for legacy ISA devices
- **16K** 16KB reserved for legacy ISA devices
- **32K** 32KB reserved for legacy ISA devices

→ 64K

54KB reserved for legacy ISA devices

6.5 Boot

Use the Boot menu (BIOS Menu 14) to configure system boot options.

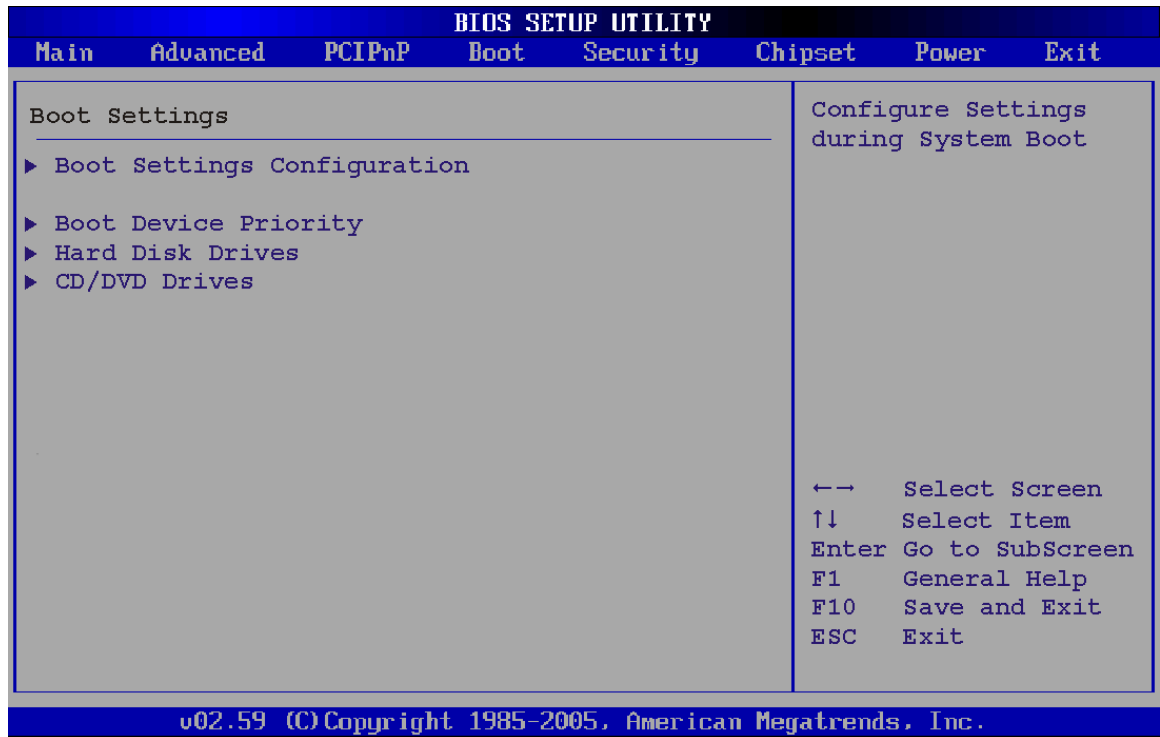

BIOS Menu 14: Boot

6.5.1 Boot Settings Configuration

Use the Boot Settings Configuration menu (BIOS Menu 14) to configure advanced system boot options.

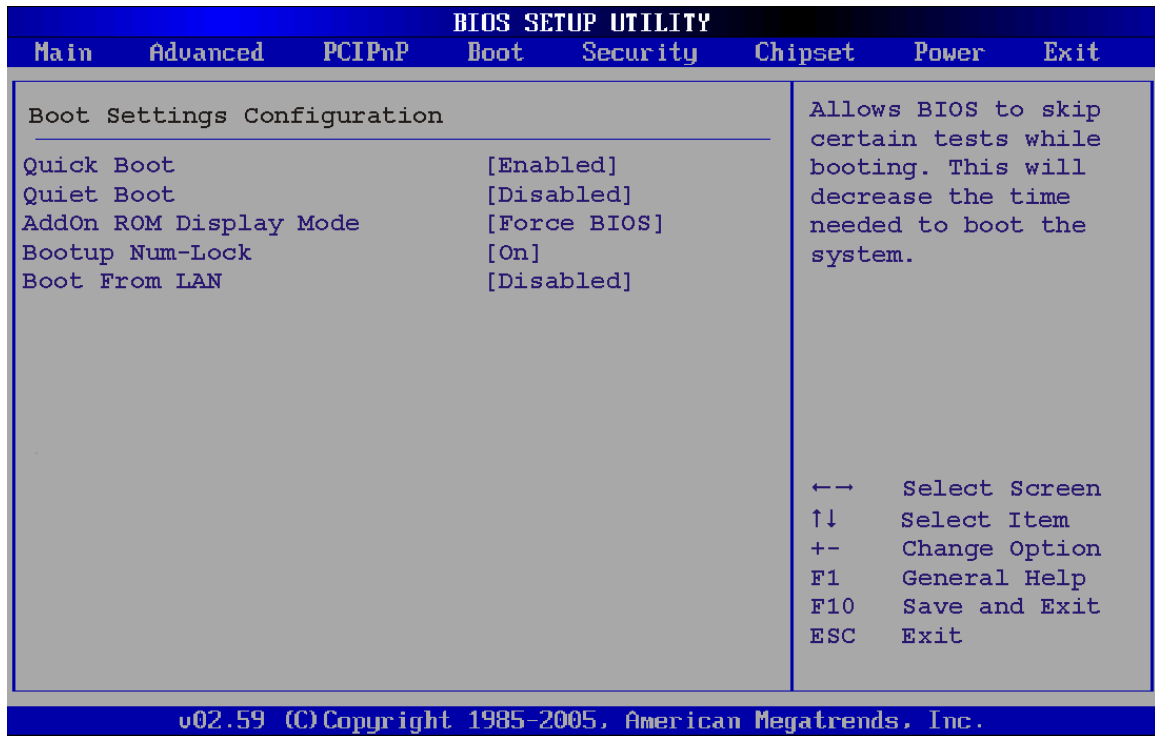

BIOS Menu 15: Boot Settings Configuration

→ Quick Boot [Enabled]

Use the **Quick Boot** BIOS option to make the computer speed up the boot process.

- **Disabled** No POST procedures are skipped
- **Enabled** **DEFAULT** Some POST procedures are skipped to decrease the system boot time

→ Quiet Boot [Disabled]

Use the **Quiet Boot** BIOS option to select the screen display when the system boots.

- **Disabled** **DEFAULT** Normal POST messages displayed
- **Enabled** OEM Logo displayed instead of POST messages

→ AddOn ROM Display Mode [Force BIOS]

The **AddOn ROM Display Mode** option allows add-on ROM (read-only memory) messages to be displayed.

- **Force BIOS** **DEFAULT** Allows the computer system to force a third party BIOS to display during system boot.
- **Keep Current** Allows the computer system to display the information during system boot.

→ **Bootup Num-Lock [Off]**

The **Bootup Num-Lock** BIOS option allows the Number Lock setting to be modified during boot up.

- **Off** **DEFAULT** Does not enable the keyboard Number Lock automatically. To use the 10-keys on the keyboard, press the Number Lock key located on the upper left-hand corner of the 10-key pad. The Number Lock LED on the keyboard lights up when the Number Lock is engaged.
- **On** Allows the Number Lock on the keyboard to be enabled automatically when the computer system boots up. This allows the immediate use of the 10-key numeric keypad located on the right side of the keyboard. To confirm this, the Number Lock LED light on the keyboard is lit.

→ **Boot From LAN Support [Disabled]**

The **BOOT From LAN Support** option enables the system to be booted from a remote system.

- **Disabled** **DEFAULT** Cannot be booted from a remote system through the LAN

→ **Enabled** **DEFAULT** Can be booted from a remote system through the LAN

6.5.2 Boot Device Priority

Use the **Boot Device Priority** menu (**BIOS Menu 16**) to specify the boot sequence from the available devices. The following options are available:

- 1st Boot Device
- 2nd Boot Device
- 3rd Boot Device

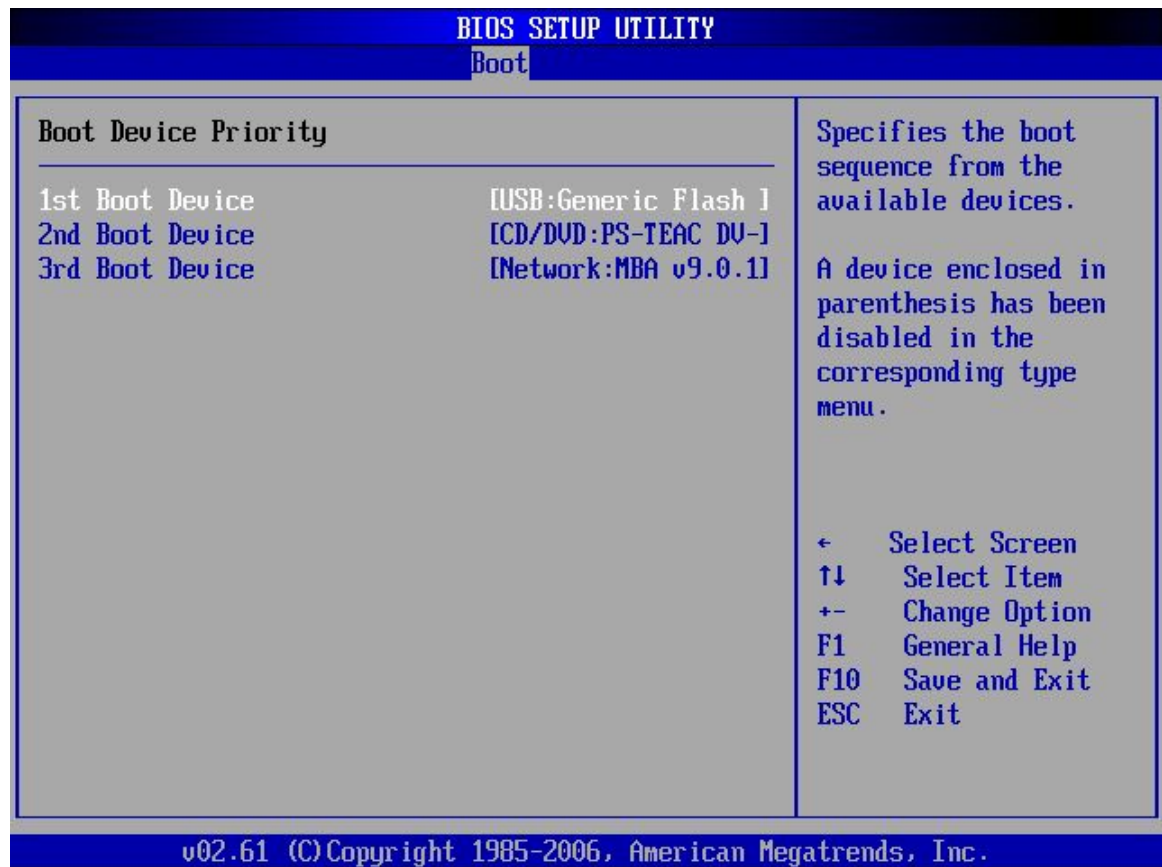

BIOS Menu 16: Boot Device Priority Settings

6.6 Security

Use the Security menu (BIOS Menu 17) to set system and user passwords.

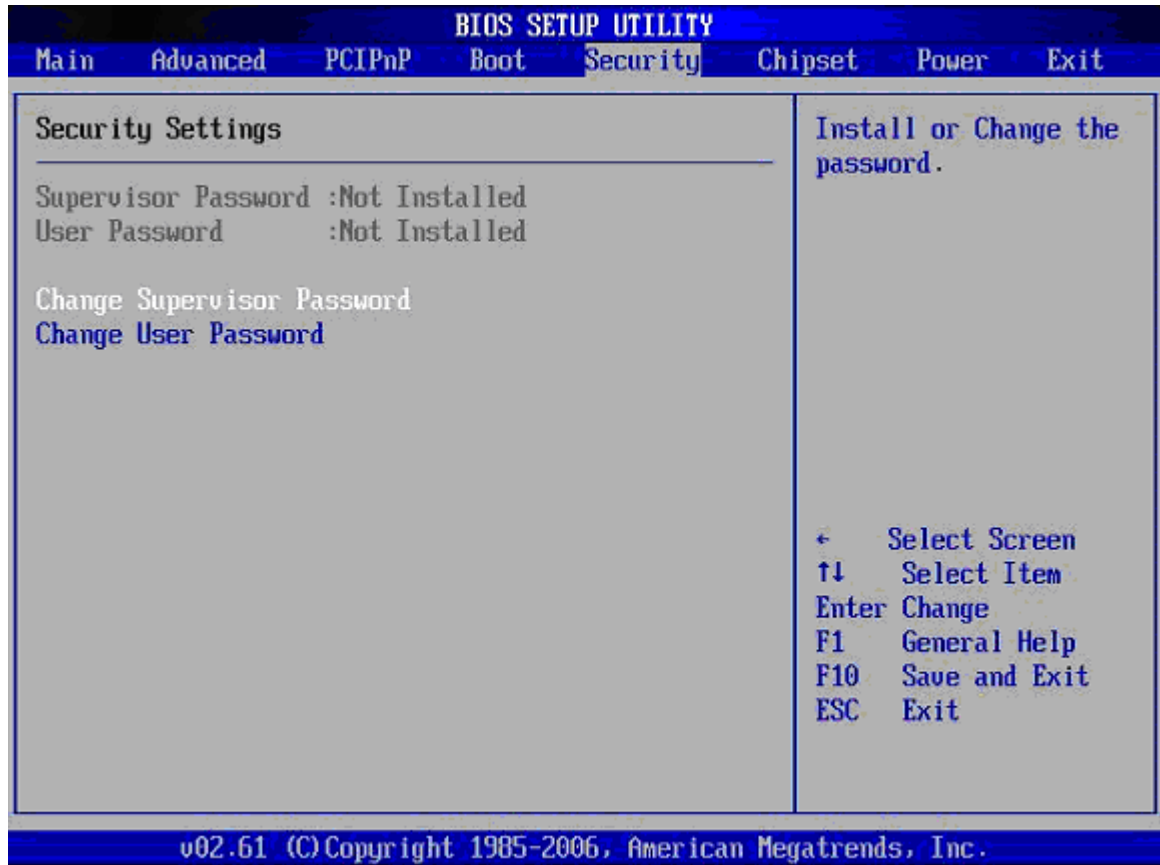

BIOS Menu 17: Security

→ Change Supervisor Password

Use the **Change Supervisor Password** to set or change a supervisor password. The default for this option is **Not Installed**. If a supervisor password must be installed, select this field and enter the password. After the password has been added, **Install** appears next to **Change Supervisor Password**.

→ Change User Password

Use the **Change User Password** to set or change a user password. The default for this option is **Not Installed**. If a user password must be installed, select this field and enter the

password. After the password has been added, **Install** appears next to **Change User Password**.

6.7 Chipset

Use the **Chipset** menu (**BIOS Menu 18**) to access the NorthBridge and SouthBridge configuration menus



WARNING!

Setting the wrong values for the Chipset BIOS selections in the Chipset BIOS menu may cause the system to malfunction.

```

BIOS SETUP UTILITY
Main  Advanced  PCIPnP  Boot  Security  Chipset  Power  Exit
-----
Advanced Chipset Settings
-----
WARNING: Setting wrong values in below sections
         may cause system to malfunction

▶ Northbridge Configuration
▶ Southbridge Configuration

Options for NB

←→  Select Screen
↑↓  Select Item
Enter Go to SubScreen
F1   General Help
F10  Save and Exit
ESC  Exit

v02.59 (C) Copyright 1985-2005, American Megatrends, Inc.
```

BIOS Menu 18: Chipset

6.7.1 North Bridge Chipset Configuration

Use the **North Bridge Chipset Configuration** menu (BIOS Menu 18) to configure the Northbridge chipset settings.

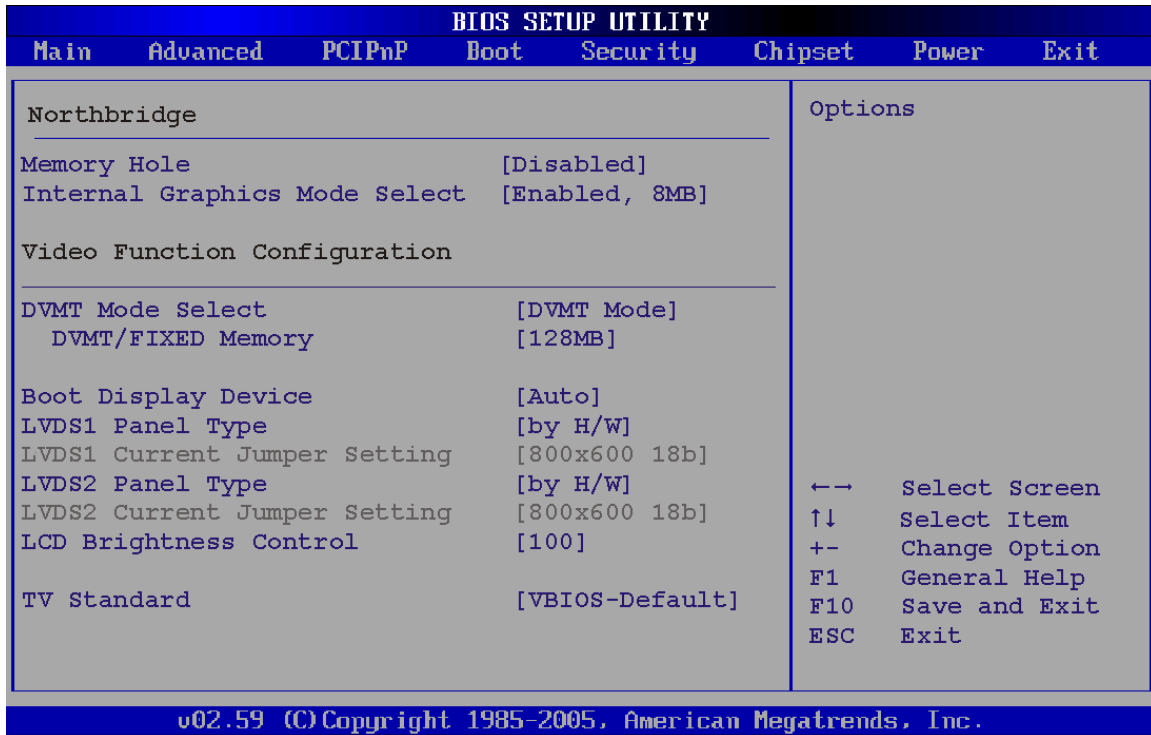

BIOS Menu 19:North Bridge Chipset Configuration

→ Memory Hole [Disabled]

The **Memory Hole** reserves the memory space between 15MB and 16MB for ISA expansion cards that require a specified area of memory to work properly. If an older ISA expansion card is used, please refer to the documentation that came with the card to see if it is necessary to reserve the space.

- **Disabled** DEFAULT Memory is not reserved for ISA expansion cards
- **Enabled** Memory is reserved for ISA expansion cards

→ Internal Graphics Mode Select [Enable, 8MB]

The **Internal Graphic Mode Select** option determines the amount of system memory that can be used by the Internal graphics device.

- ➔ **Disable**
- ➔ **Enable, 1MB** 1MB of memory used by internal graphics device
- ➔ **Enable, 8MB** **DEFAULT** 8MB of memory used by internal graphics device

➔ **DVMT Mode Select [DVMT Mode]**

Use the **DVMT Mode Select** option to select the Intel Dynamic Video Memory Technology (DVMT) operating mode.

- ➔ **Fixed Mode** A fixed portion of graphics memory is reserved as graphics memory.
- ➔ **DVMT Mode** **DEFAULT** Graphics memory is dynamically allocated according to the system and graphics needs.
- ➔ **Combo Mode** A fixed portion of graphics memory is reserved as graphics memory. If more memory is needed, graphics memory is dynamically allocated according to the system and graphics needs.

➔ **DVMT/FIXED Memory**

Use the **DVMT/FIXED Memory** option to specify the maximum amount of memory that can be allocated as graphics memory. This option can only be configured for if **DVMT Mode** or **Fixed Mode** is selected in the **DVMT Mode Select** option. If **Combo Mode** is selected, the maximum amount of graphics memory is 128MB. Configuration options are listed below.

- 64MB
- 128MB **DEFAULT**
- Maximum DVMT

→ **Boot Display Device [CRT]**

The **Boot Display Device** BIOS option selects the display device the system uses when it boots. The available options are listed below:

- Auto **DEFAULT**
- CRT
- TV
- LFP
- LFP1

→ **LVDS Panel Type**

Use the **LVDS Panel Type** to determine the LCD panel resolution. Configuration options are listed below:

- 640 x 480 18b
- 800 x 480 18b
- 800 x 600 18b
- 1024 x 768 18b
- 1280 x 1024 36b
- 1400 x 1050 36b
- 1440 x 900 36b
- 1600 x 1200 36b
- by H/W

→ **LCD Brightness Control**

Use the **LCD Brightness Control** option to specify the brightness of the LCD panel as a percentage. Default setting is 100%

→ **TV Standard**

The **TV Standard** option specifies the TV type connected to the system.

- **VBIOS-Default** **DEFAULT** TV type is set to VBIOS-Default
- **NTSC** TV type is set to NTSC

- ➔ PAL TV type is set to PAL
- ➔ SECAM TV type is set to SECAM
- ➔ SMPTE240M TV type is set to SMPTE240M
- ➔ ITU-R television TV type is set to ITU-R television
- ➔ SMPTE260M TV type is set to SMPTE260M
- ➔ SMPTE295M TV type is set to SMPTE295M
- ➔ SMPTE296M TV type is set to SMPTE296M
- ➔ EIA-770.2 TV type is set to EIA-770.2
- ➔ EIA-770.3 TV type is set to EIA-770.3

6.7.2 SouthBridge Configuration

The **SouthBridge Configuration** menu (BIOS Menu 20) the southbridge chipset to be configured.

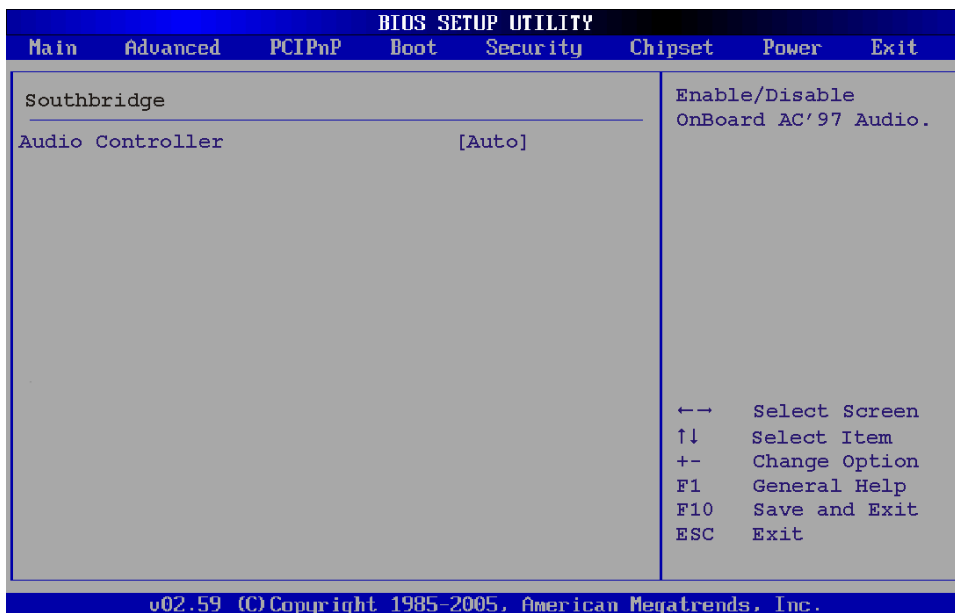

BIOS Menu 20:SouthBridge Chipset Configuration

→ **Audio Controller [All Disabled]**

The **Audio Controller** option enables or disables the audio controller.

- **Azalia** Audio controller configured as Azalia
- **AC'97 Audio Only** The on-board AC'97 audio controller is enabled.
- **All Disabled** **DEFAULT** The on-board audio controller is disabled.

6.8 Exit

Use the **Exit** menu (**BIOS Menu 21**) to load default BIOS values, optimal failsafe values and to save configuration changes.



BIOS Menu 21:Exit

→ **Save Changes and Exit**

Use the **Save Changes and Exit** option to save the changes made to the BIOS options and to exit the BIOS configuration setup program.

→ **Discard Changes and Exit**

Use the **Discard Changes and Exit** option to exit the BIOS configuration setup program without saving the changes made to the system.

→ **Discard Changes**

Use the **Discard Changes** option to discard the changes and remain in the BIOS configuration setup program.

→ **Load Optimal Defaults**

Use the **Load Optimal Defaults** option to load the optimal default values for each of the parameters on the Setup menus. **F9 key can be used for this operation.**

→ **Load Failsafe Defaults**

Use the **Load Failsafe Defaults** option to load failsafe default values for each of the parameters on the Setup menus. **F8 key can be used for this operation.**

Chapter

7

Software Drivers

7.1 Available Software Drivers

The following drivers can be installed on the system:

- Chipset
- VGA
- LAN
- Audio

Installation instructions are given below.

7.2 Starting the Driver Program

To access the driver installation programs, please do the following.

Step 1: Insert the CD-ROM that came with the system into a CD-ROM drive attached to the system.

Step 2: The screen in Figure 7-1 appears.

Step 4: The screen in appears.

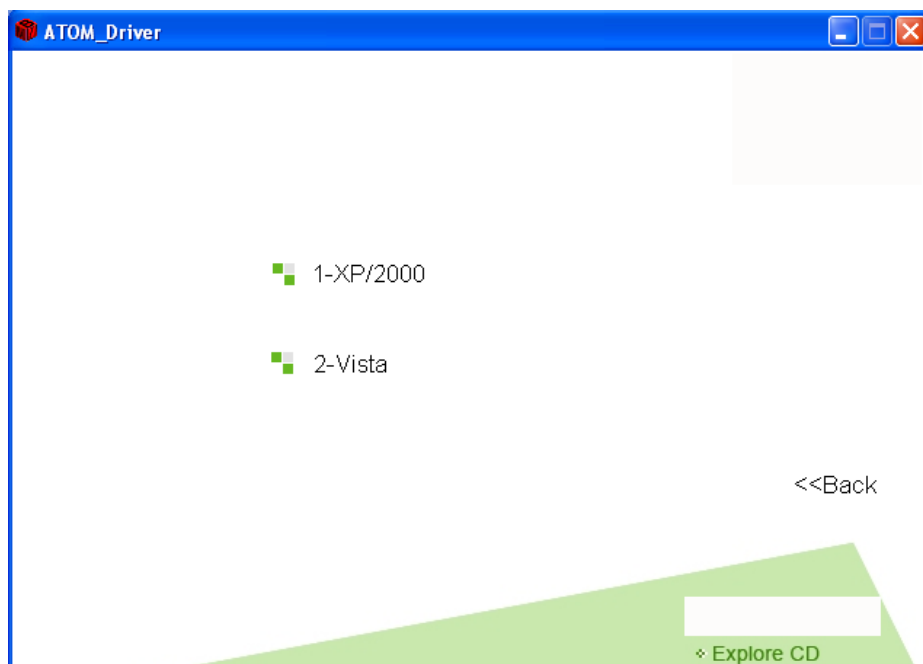

Figure 7-2: Select Operating System

Step 5: Select the operating system installed on the 3308440 system. This manual describes the installation for a Windows XP operating system.

Step 6: The list of drivers in Figure 7-3 appears.

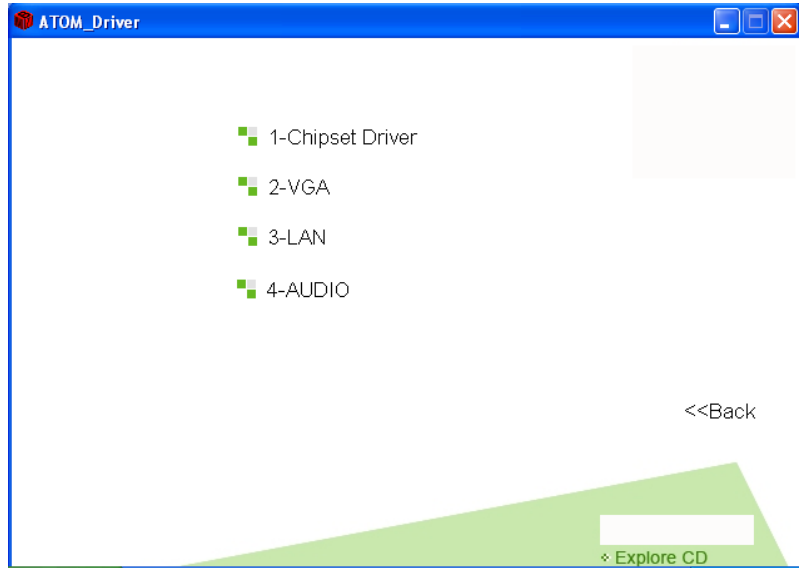

Figure 7-3: Drivers

7.3 Chipset Driver Installation

To install the chipset driver, please do the following.

Step 1: Access the driver list shown in Figure 7-3. (See **Section 7.2**)

Step 2: Click "1-Chipset Driver"

Step 3: The setup files are extracted as shown in Figure 7-4.

A



Figure 7-4: Chipset Driver Screen

Step 4: When the setup files are completely extracted the **Welcome Screen** in Figure 7-5 appears.



Figure 7-5: Chipset Driver Welcome Screen

Step 5: Click **Next** to continue.

Step 6: The license agreement in Figure 7-6 appears.

Step 7: Read the **License Agreement**.

Step 8: Click the **Yes** icon to continue.



Figure 7-6: Chipset Driver License Agreement

Step 9: The Read Me file in Figure 7-7 appears.

Step 10: Click **Next** to continue.

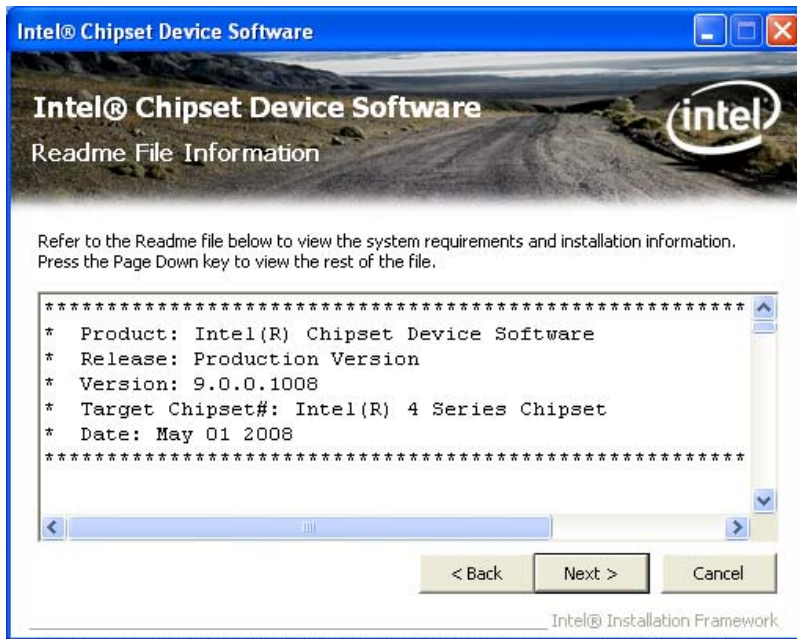

Figure 7-7: Chipset Driver Read Me File

Step 11: Setup Operations are performed as shown in Figure 7-8.



Figure 7-8: Chipset Driver Setup Operations

Step 12: Once the **Setup Operations** are complete, click the **Next** icon to continue.

Step 13: The **Finish** screen appears.

Step 14: Select “**Yes, I want to restart the computer now**” and click the **Finish** icon.

See Figure 7-9.



Figure 7-9: Chipset Driver Installation Finish Screen

7.4 VGA Driver Installation

To install the VGA driver, please do the following.

Step 1: Access the driver list shown in Figure 7-3. (See **Section 7.2**)

Step 2: Click “**2-VGA**”

Step 3: The VGA Read Me file in Figure 7-10 appears.

Step 4: Click **Next** to continue.

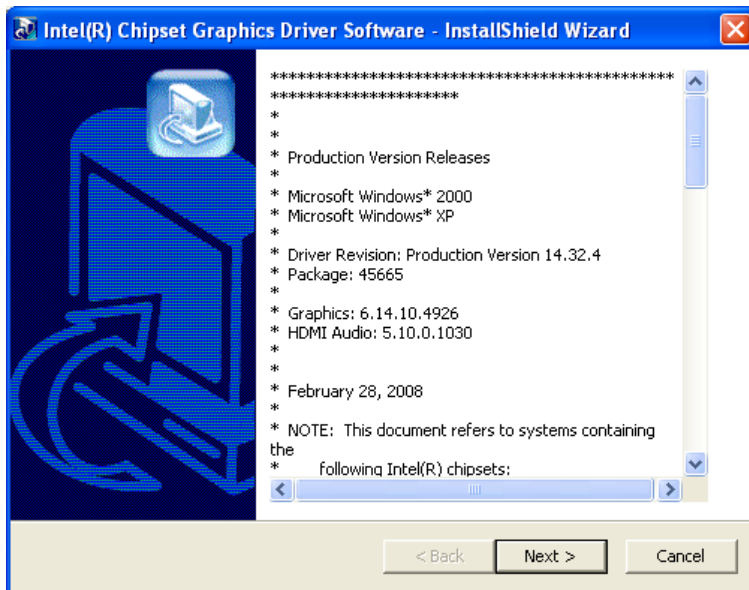

Figure 7-10: VGA Driver Read Me File

Step 5: The installation files are extracted. See Figure 7-11.

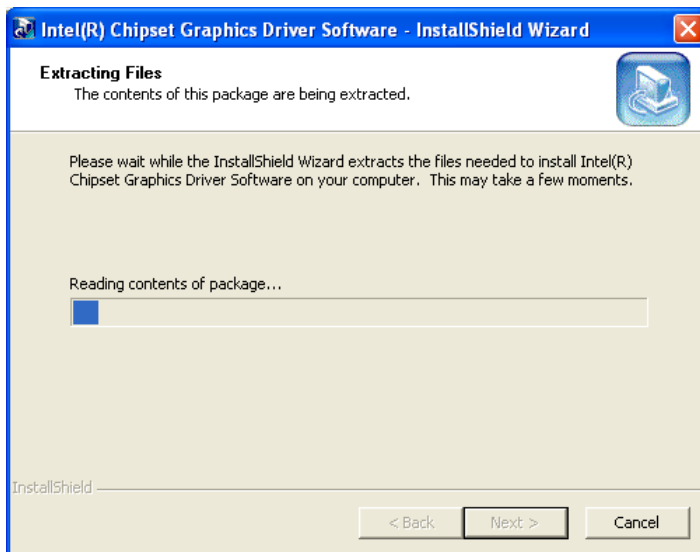

Figure 7-11: VGA Driver Setup Files Extracted

Step 6: The **Welcome Screen** in Figure 7-12 appears.



Figure 7-12: VGA Driver Welcome Screen

- Step 7:** Click **Next** to continue.
- Step 8:** The license agreement in Figure 7-13 appears.
- Step 9:** Read the **License Agreement**.
- Step 10:** Click the **Yes** icon to continue.

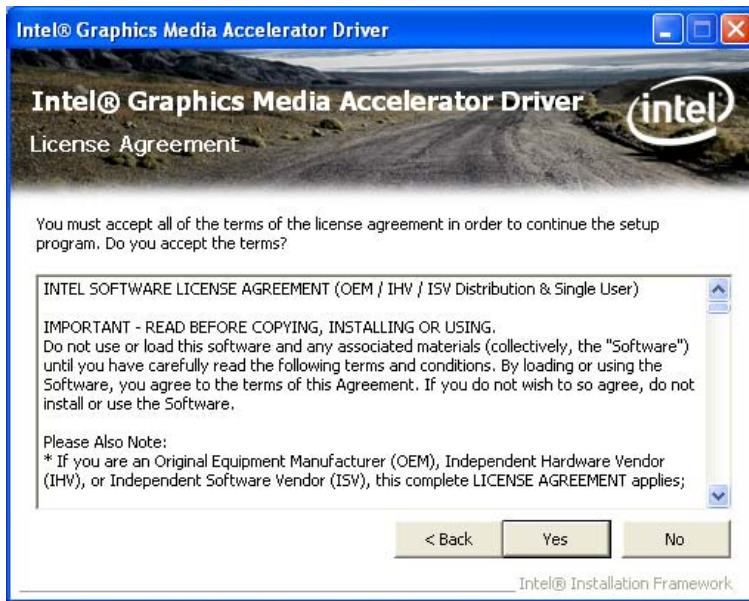

Figure 7-13: VGA Driver License Agreement

Step 11: The Read Me file in Figure 7-14 appears.

Step 12: Click **Next** to continue.

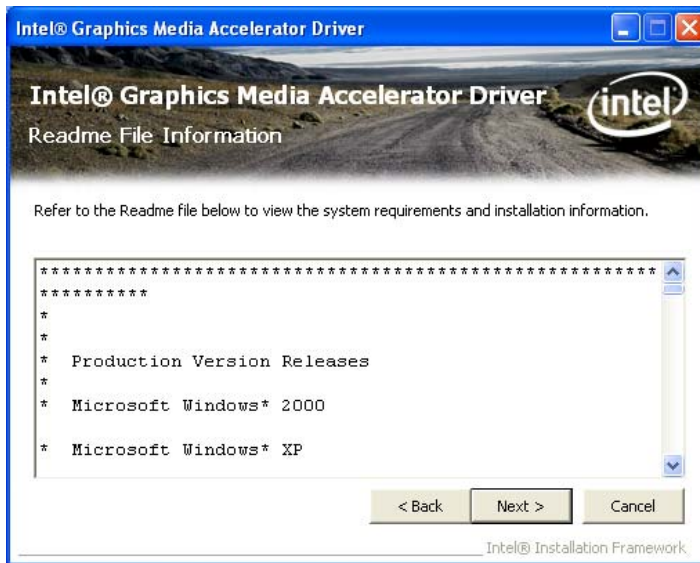

Figure 7-14: VGA Driver Read Me File

Step 13: Setup Operations are performed as shown in Figure 7-15.

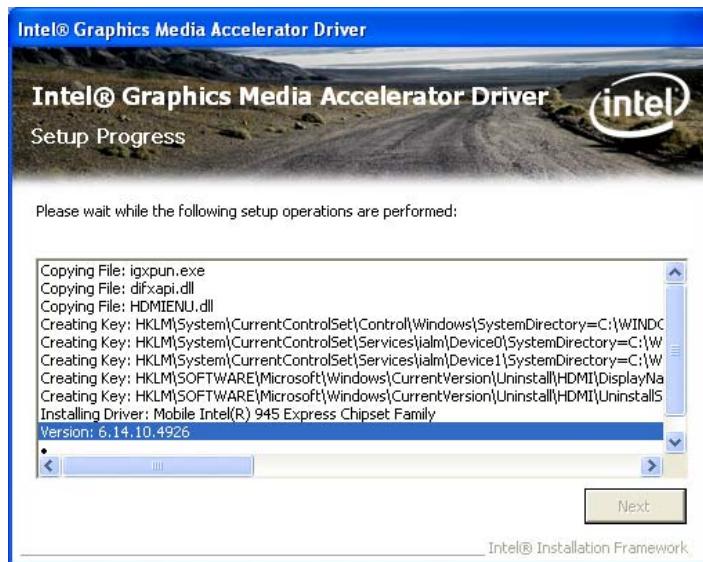

Figure 7-15: VGA Driver Setup Operations

Step 14: Once the **Setup Operations** are complete, click the **Next** icon to continue.

Step 15: The **Finish** screen appears.

Step 16: Select “**Yes, I want to restart the computer now**” and click the **Finish** icon.

See Figure 7-16.

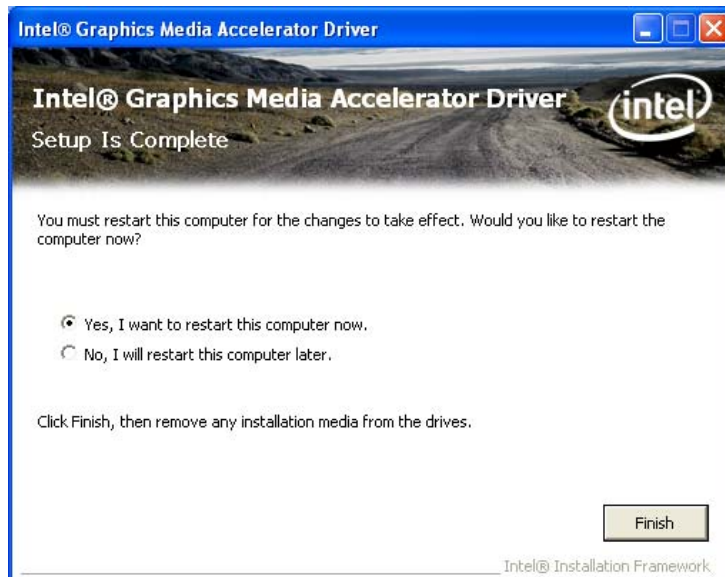

Figure 7-16: VGA Driver Installation Finish Screen

7.5 LAN Driver Installation

To install the chipset driver, please do the following.

Step 1: Access the driver list shown in Figure 7-3. (See **Section 7.2**)

Step 2: Click “**3-LAN**”

Step 3: The **Welcome** screen in Figure 7-17 appears.

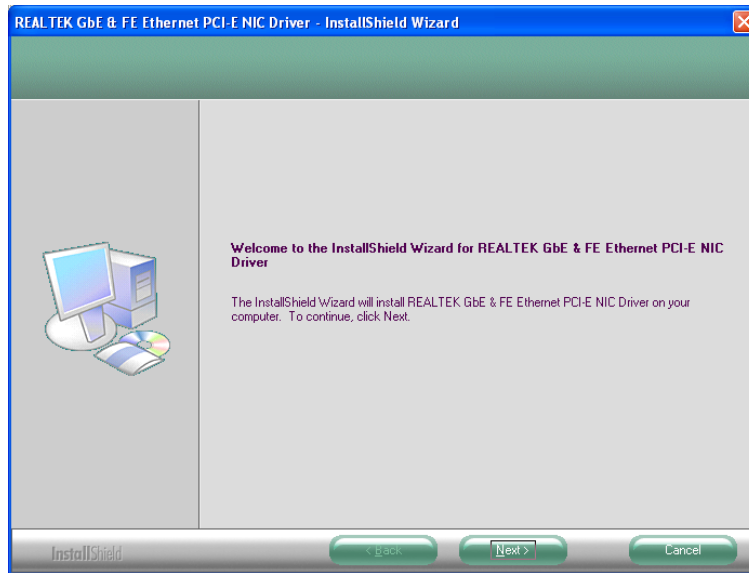

Figure 7-17: LAN Driver Welcome Screen

Step 4: Click **Next** to continue.

Step 5: The **Ready to Install** screen in Figure 7-18 appears.

Step 6: Click **Next** to proceed with the installation.

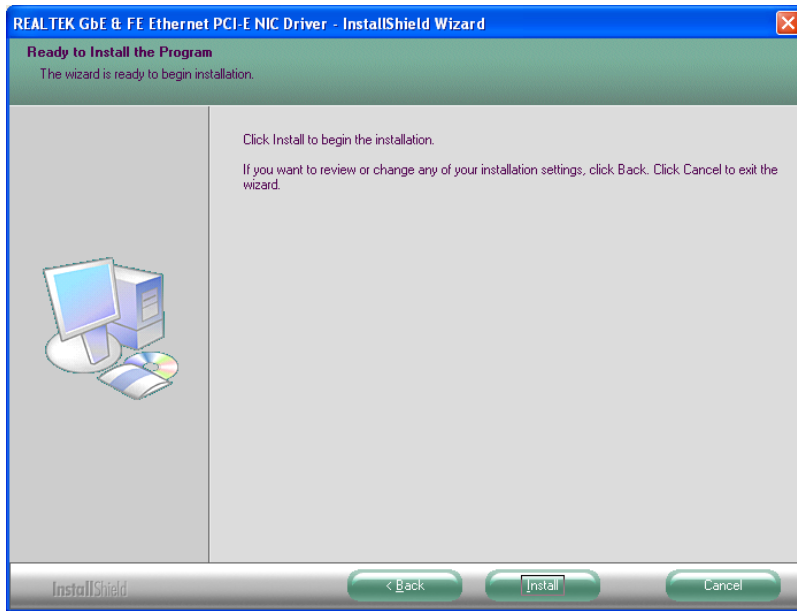

Figure 7-18: LAN Driver Welcome Screen

Step 7: The program begins to install.

Step 8: The installation progress can be monitored in the progress bar shown in Figure 7-19.

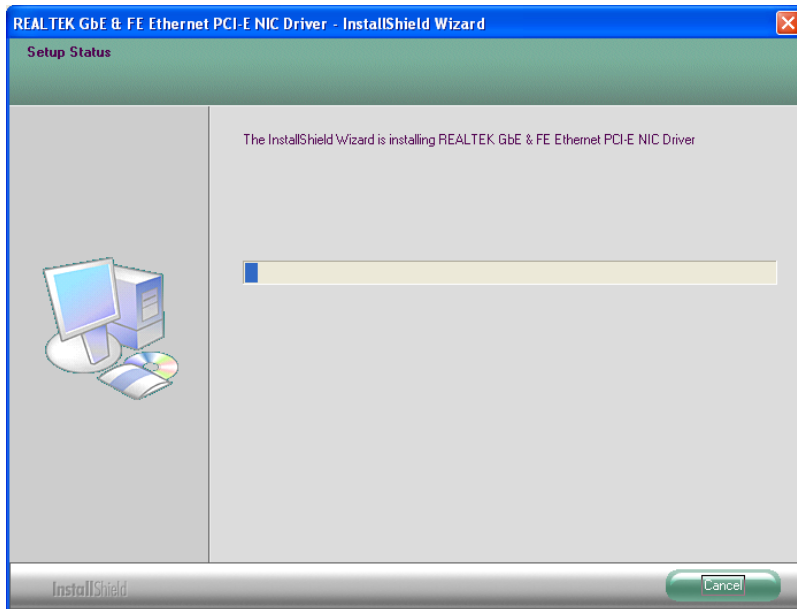

Figure 7-19: LAN Driver Installation

Step 9: When the driver installation is complete, the screen in Figure 7-20 appears.

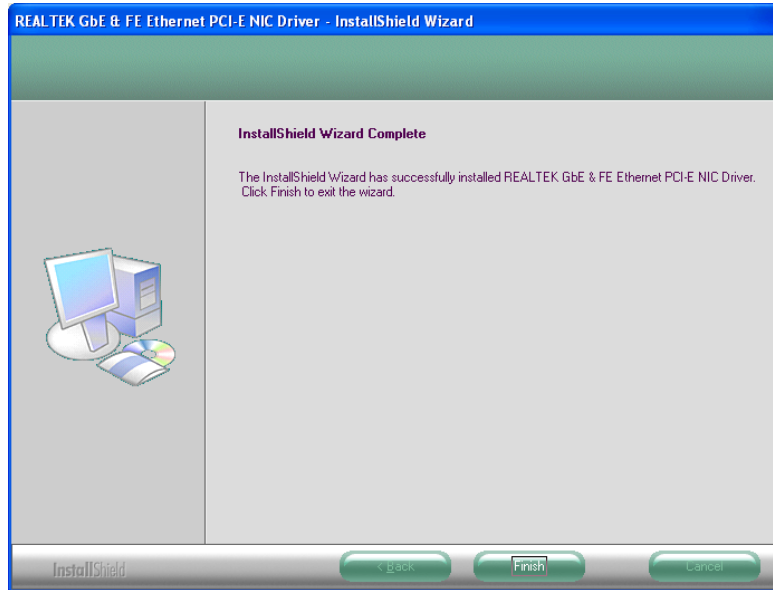

Figure 7-20: LAN Driver Installation Complete

7.6 Audio Driver Installation

To install the chipset driver, please do the following.

Step 1: Access the driver list shown in Figure 7-3. (See **Section 7.2**)

Step 2: Click "**4-Audio**"

Step 3: The screen in Figure 7-21 appears.

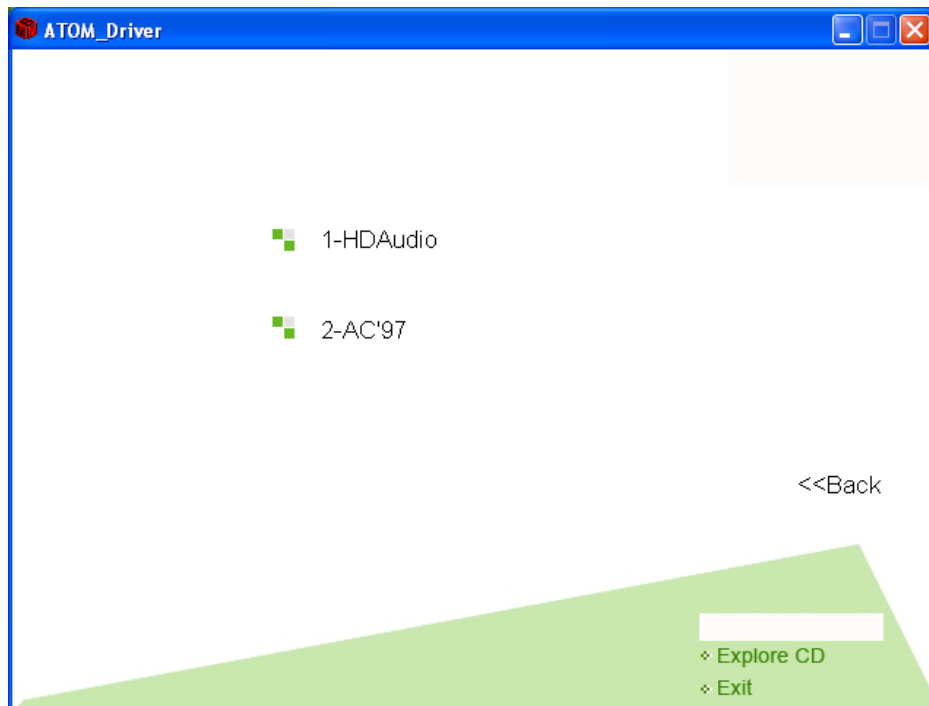

Figure 7-21: Audio Driver Options

7.6.1 HD Audio Installation

To install the HD Audio driver, please do the following:

Step 1: Select "1-HDAudio" in Figure 7-21.

Step 2: Installation files are extracted as shown in Figure 7-22.

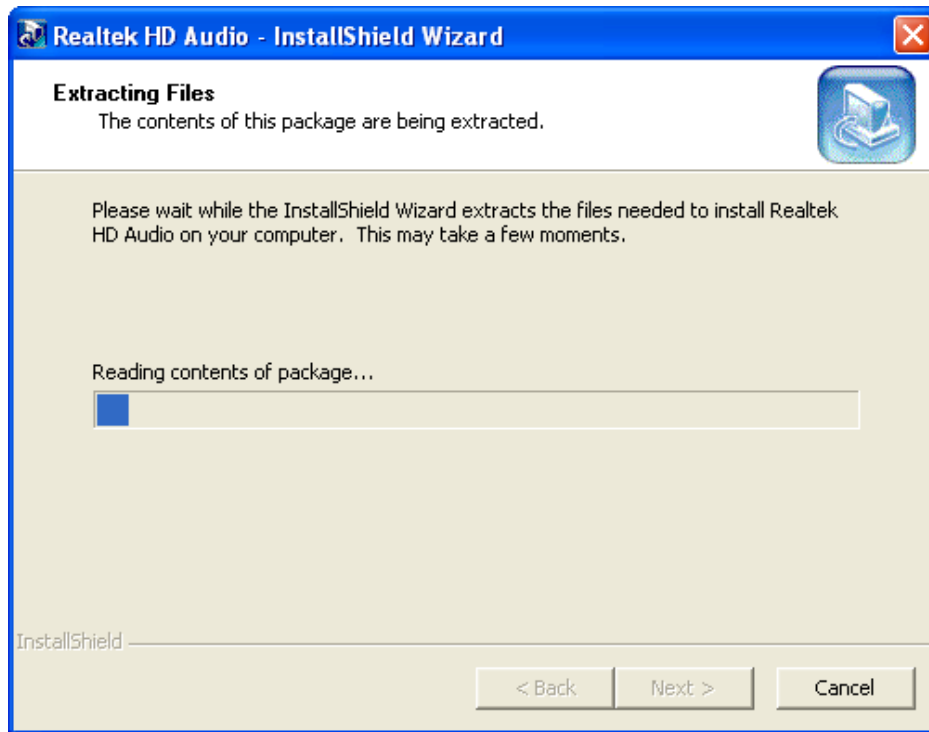

Figure 7-22: Extract HD Audio Driver Installation Files

Step 3: The **Welcome** screen in Figure 7-23 appears.

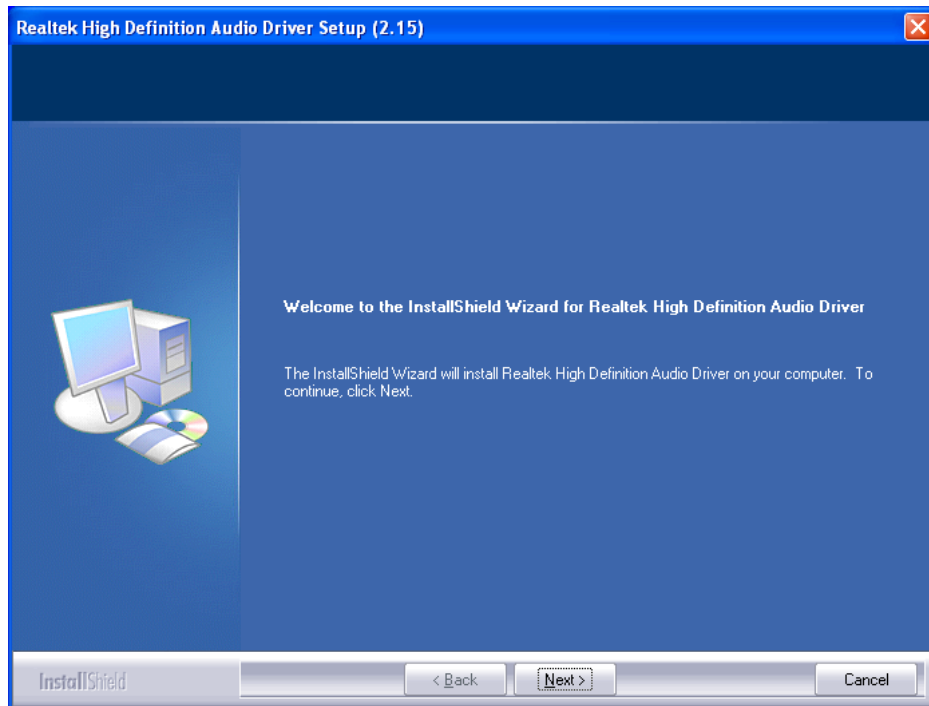

Figure 7-23: HD Audio Driver Welcome Screen

Step 4: Click **Next** to continue.

Step 5: The system updates. See Figure 7-24.

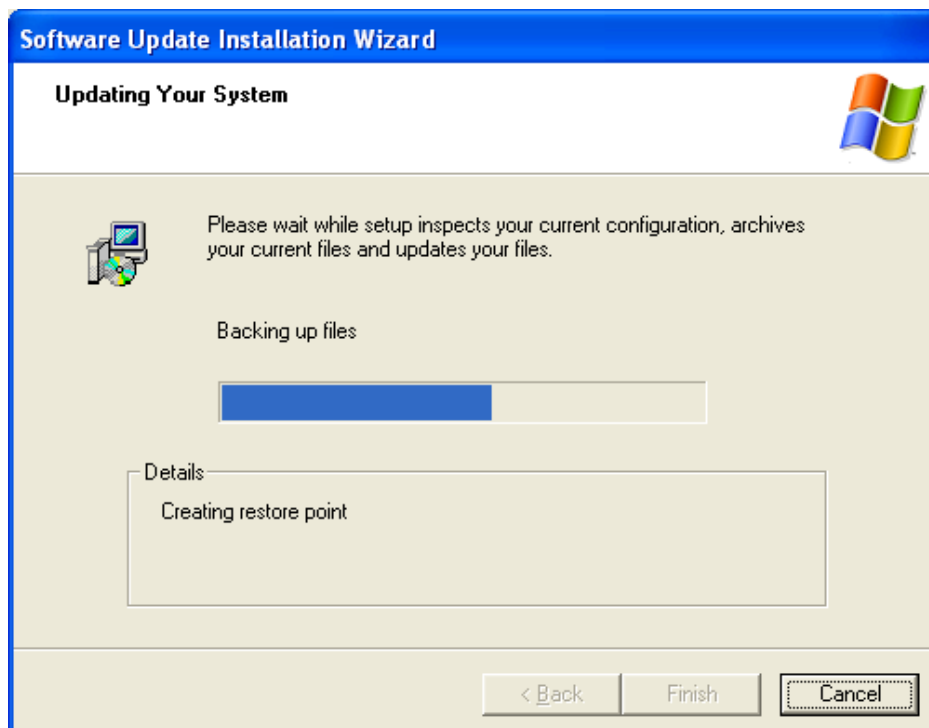

Figure 7-24: System Update

Step 6: Follow the installation instructions until the HD Audio driver installation is complete.

7.6.2 AC'97 Driver Installation

To install the AC'97 audio driver, please do the following:

Step 1: Select "2-AC'97" in Figure 7-21

Step 2: The installation files are extracted as shown in Figure 7-25.

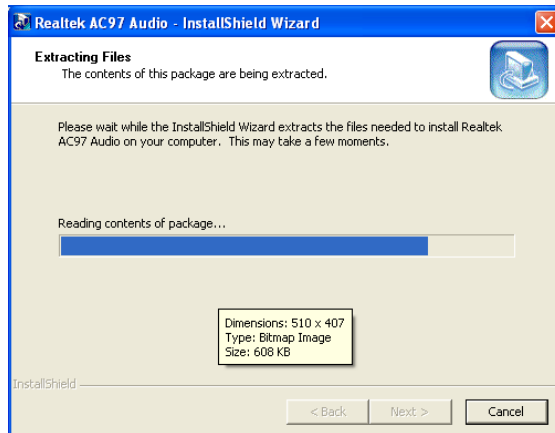

Figure 7-25: AC'97 Driver Installation File Extraction

Step 3: The AC'97 Driver Installation screen in Figure 7-26 appears.

Step 4: Click **Next** to continue.

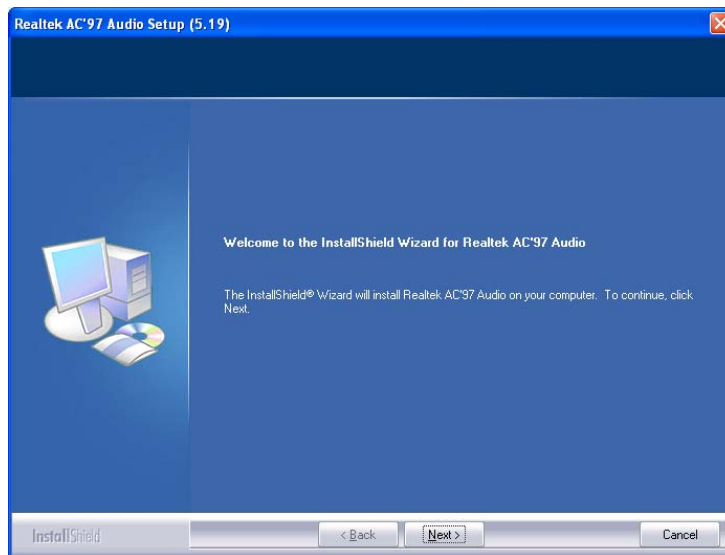

Figure 7-26: AC'97 Driver Installation Welcome Screen

Step 5: The Verification window in Figure 7-27 may appear.

Step 6: Click **“Continue Anyway.”**



Figure 7-27: AC'97 Driver Installation Verification

Step 7: The driver installation begins. See Figure 7-28.

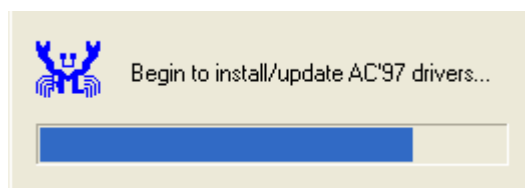

Figure 7-28: AC'97 Driver Installation

Step 8: When the driver is installed, the driver installation finish screen in Figure 7-29 appears.

Step 9: Select "Yes, I wish to restart my computer now" And click **Finish**

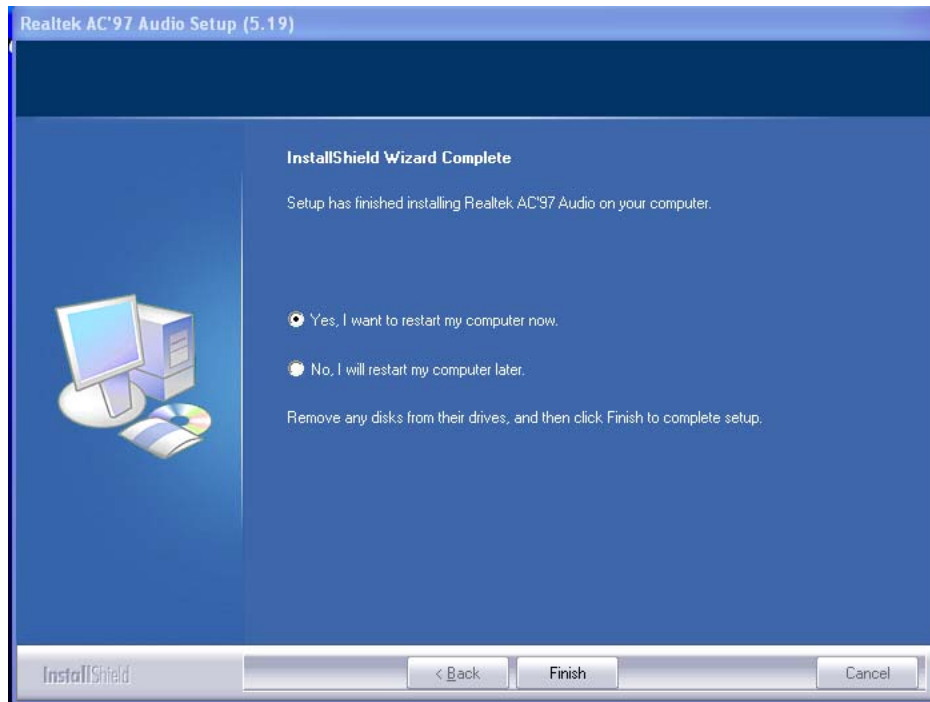

Figure 7-29: AC'97 Driver Installation Complete

Step 10: The system reboots.

Appendix

A

BIOS Menu Options

→ System Overview	111
→ System Time [xx:xx:xx].....	112
→ System Date [xx/xx/xx].....	112
→ ATA/IDE Configurations [Compatible]	115
→ Legacy IDE Channels [PATA Pri, SATA Sec].....	116
→ IDE Master and IDE Slave	116
→ Auto-Detected Drive Parameters	117
→ Type [Auto].....	118
→ ZIP	118
→ LS-120.....	118
→ LBA/Large Mode [Auto]	119
→ Block (Multi Sector Transfer) [Auto].....	119
→ PIO Mode [Auto]	119
→ DMA Mode [Auto]	120
→ S.M.A.R.T [Auto]	121
→ 32Bit Data Transfer [Enabled]	121
→ Parallel Port Address [Disabled].....	122
→ Parallel Port Mode [Normal]	123
→ Parallel Port IRQ [IRQ7]	123
→ Serial Port1 Address [3F8/IRQ4]	124
→ Serial Port1 Mode [Normal]	124
→ Serial Port2 Address [2F8/IRQ3]	124
→ Serial Port2 Mode [Normal]	125
→ Serial Port3 Address [3E8]	125
→ Serial Port3 IRQ [11].....	125
→ Serial Port4 Address [2E8]	125
→ Serial Port4 IRQ [10].....	126
→ CPU FAN Mode Setting [Full On Mode].....	127
→ CPU Temp. Limit of OFF [000].....	128
→ CPU Temp. Limit of Start [020].....	128
→ CPU Fan Start PWM [070]	129

→ Slope PWM [0.5 PWM]	129
→ Suspend Mode [S1(POS)]	132
→ Restore on AC Power Loss [Last State].....	133
→ Power Button Mode [On/Off]	133
→ Resume on Keyboard/Mouse [Disabled].....	134
→ Resume on Ring [Disabled].....	134
→ Resume on PCI-Express WAKE# [Enabled]	134
→ Resume On RTC Alarm [Disabled]	135
→ RTC Alarm Date (Days)	135
→ System Time	135
→ Remote Access [Disabled]	136
→ Serial Port Number	136
→ Serial Port Mode	136
→ Flow Control.....	136
→ Redirection after BIOS POST	136
→ Terminal Type	137
→ VT-UTF8 Combo Key Support.....	137
→ Serial Port Number [COM1]	137
→ Base Address, IRQ [2F8h,3]	137
→ Serial Port Mode [115200 8,n,1]	137
→ Flow Control [None]	138
→ Redirection After BIOS POST [Always].....	138
→ Terminal Type [ANSI]	138
→ VT-UTF8 Combo Key Support [Disabled]	138
→ Sredir Memory Display Delay [Disabled]	139
→ USB Functions [Enabled]	140
→ USB 2.0 Controller [Enabled]	140
→ USB2.0 Controller Mode [HiSpeed]	140
→ Legacy USB Support [Enabled]	141
→ IRQ# [Available]	142
→ DMA Channel# [Available]	143
→ Reserved Memory Size [Disabled].....	143

→ Quick Boot [Enabled]	145
→ Quiet Boot [Disabled].....	145
→ AddOn ROM Display Mode [Force BIOS].....	145
→ Bootup Num-Lock [Off].....	146
→ Boot From LAN Support [Disabled].....	146
→ Change Supervisor Password.....	148
→ Change User Password	148
→ Memory Hole [Disabled].....	150
→ Internal Graphics Mode Select [Enable, 8MB]	150
→ DVMT Mode Select [DVMT Mode]	151
→ DVMT/FIXED Memory	151
→ Boot Display Device [CRT]	152
→ LVDS Panel Type	152
→ LCD Brightness Control.....	152
→ TV Standard.....	152
→ Audio Controller [All Disabled]	154
→ Save Changes and Exit	155
→ Discard Changes and Exit	155
→ Discard Changes	155
→ Load Optimal Defaults	155
→ Load Failsafe Defaults	155

Appendix

B

Terminology

AC '97	Audio Codec 97 (AC'97) refers to a codec standard developed by Intel® in 1997.
ACPI	Advanced Configuration and Power Interface (ACPI) is an OS-directed configuration, power management, and thermal management interface.
AHCI	Advanced Host Controller Interface (AHCI) is a SATA Host controller register-level interface.
ATA	The Advanced Technology Attachment (ATA) interface connects storage devices including hard disks and CD-ROM drives to a computer.
APM	The Advanced Power Management (APM) application program interface (API) enables the inclusion of power management in the BIOS.
ARMD	An ATAPI Removable Media Device (ARMD) is any ATAPI device that supports removable media, besides CD and DVD drives.
ASKIR	Amplitude Shift Keyed Infrared (ASKIR) is a form of modulation that represents a digital signal by varying the amplitude (“volume”) of the signal. A low amplitude signal represents a binary 0, while a high amplitude signal represents a binary 1.
BIOS	The Basic Input/Output System (BIOS) is firmware that is first run when the computer is turned on and can be configured by the end user
CODEC	The Compressor-Decompressor (CODEC) encodes and decodes digital audio data on the system.
CMOS	Complimentary metal-oxide-conductor is a type of integrated circuit used in chips like static RAM and microprocessors.
COM	COM is used to refer to serial ports. Serial ports offer serial communication to expansion devices. The serial port on a personal

	computer is usually a male DE-9 connector.
DAC	The Digital-to-Analog Converter (DAC) converts digital signals to analog signals.
DDR	Double Data Rate refers to a data bus transferring data on both the rising and falling edges of the clock signal.
DMA	Direct Memory Access (DMA) enables some peripheral devices to bypass the system processor and communicate directly with the system memory.
DIMM	Dual Inline Memory Modules are a type of RAM that offer a 64-bit data bus and have separate electrical contacts on each side of the module.
EHCI	The Enhanced Host Controller Interface (EHCI) specification is a register-level interface description for USB 2.0 Host Controllers.
FSB	The Front Side Bus (FSB) is the bi-directional communication channel between the processor and the Northbridge chipset.
GbE	Gigabit Ethernet (GbE) is an Ethernet version that transfers data at 1.0 Gbps and complies with the IEEE 802.3-2005 standard.
GPIO	General purpose input
IrDA	Infrared Data Association (IrDA) specify infrared data transmission protocols used to enable electronic devices to wirelessly communicate with each other.
L1 Cache	The Level 1 Cache (L1 Cache) is a small memory cache built into the system processor.
L2 Cache	The Level 2 Cache (L2 Cache) is an external processor memory cache.
LVDS	Low-voltage differential signaling (LVDS) is a dual-wire, high-speed differential electrical signaling system commonly used to connect LCD displays to a computer.

MAC	The Media Access Control (MAC) protocol enables several terminals or network nodes to communicate in a LAN, or other multipoint networks.
PCIe	PCI Express (PCIe) is a communications bus that uses dual data lines for full-duplex (two-way) serial (point-to-point) communications between the SBC components and/or expansion cards and the SBC chipsets. Each line has a 2.5 Gbps data transmission rate and a 250 MBps sustained data transfer rate.
POST	The Power-on Self Test (POST) is the pre-boot actions the system performs when the system is turned-on.
QVGA	Quarter Video Graphics Array (QVGA) refers to a display with a resolution of 320 x 240 pixels.
RAID	Redundant Array of Inexpensive Disks (RAID) refers to redundantly backing up data on multiple disks to ensure that if one disk fails, the data is not lost and can be restored from the remaining disks in the array.
RAM	Random Access Memory (RAM) is a form of storage used in computer. RAM is volatile memory, so it loses its data when power is lost. RAM has very fast data transfer rates compared to other storage like hard drives.
SATA	Serial ATA (SATA) is a serial communications bus designed for data transfers between storage devices and the computer chipsets. The SATA bus has transfer speeds up to 1.5 Gbps and the SATA II bus has data transfer speeds of up to 3.0 Gbps.
S.M.A.R.T	Self Monitoring Analysis and Reporting Technology (S.M.A.R.T) refers to automatic status checking technology implemented on hard disk drives.
UART	Universal Asynchronous Receiver-transmitter (UART) is responsible for

asynchronous communications on the system and manages the system's serial communication (COM) ports.

UHCI

The Universal Host Controller Interface (UHCI) specification is a register-level interface description for USB 1.1 Host Controllers.

USB

The Universal Serial Bus (USB) is an external bus standard for interfacing devices. USB 1.1 supports 12Mbps data transfer rates, while USB 2.0 supports 480Mbps data transfer rates.

VGA

The Video Graphics Array (VGA) is a graphics display system developed by IBM.

Appendix

C

DIO Interface

C.1 DIO Interface Introduction

The DIO connector on the 3308440 is interfaced to GPIO ports on the ITE IT8718 Super I/O chipset. The DIO has both 4-bit digital inputs and 4-bit digital outputs. The digital inputs and digital outputs are generally control signals that control the on/off circuit of external devices or TTL devices. Data can be read or written to the selected address to enable the DIO functions.



NOTE:

For further information, please refer to the datasheet for the ITE IT8718 Super I/O chipset.

C.2 DIO Connector Pinouts

The following table describes how the DIO connector pins are connected to the Super I/O GPIO port.

Pin	Description	Super I/O Pin	Super I/O Pin Description
1	Ground	N/A	N/A
2	VCC	N/A	N/A
3	Output 3	GP23	General Purpose I/O Port 2 Bit 3
4	Output 2	GP22	General Purpose I/O Port 2 Bit 2
5	Output 1	GP21	General Purpose I/O Port 2 Bit 1
6	Output 0	GP20	General Purpose I/O Port 2 Bit 0
7	Input 3	GP33	General Purpose I/O 33
8	Input 2	GP32	General Purpose I/O 32
9	Input 1	GP31	General Purpose I/O 31
10	Input 0	GP30	General Purpose I/O 30

C.3 Assembly Language Samples

C.3.1 Enable the DIO Input Function

The BIOS interrupt call INT 15H controls the digital I/O. An assembly program to enable digital I/O input functions is listed below.

MOV	AX, 6F08H	Sets the digital port as input
INT	15H	Initiates the INT 15H BIOS call

C.3.2 Enable the DIO Output Function

The BIOS interrupt call INT 15H controls the digital I/O. An assembly program to enable digital I/O output functions is listed below.

MOV	AX, 6F09H	Sets the digital port as output
MOV	BL, 09H	
INT	15H	Initiates the INT 15H BIOS call

Appendix

D

Watchdog Timer

The Watchdog Timer is provided to ensure that standalone systems can always recover from catastrophic conditions that cause the CPU to crash. This condition may have occurred by external EMI or a software bug. When the CPU stops working correctly, Watchdog Timer either performs a hardware reset (cold boot) or a Non-Maskable Interrupt (NMI) to bring the system back to a known state.

A BIOS function call (INT 15H) is used to control the Watchdog Timer:

INT 15H:

AH – 6FH Sub-function:	
AL – 2:	Sets the Watchdog Timer's period.
BL:	Time-out value (Its unit-second is dependent on the item "Watchdog Timer unit select" in CMOS setup).

Table D-1: AH-6FH Sub-function

Call sub-function 2 to set the time-out period of Watchdog Timer first. If the time-out value is not zero, the Watchdog Timer starts counting down. While the timer value reaches zero, the system resets. To ensure that this reset condition does not occur, calling sub-function 2 must periodically refresh the Watchdog Timer. However, the Watchdog timer is disabled if the time-out value is set to zero.

A tolerance of at least 10% must be maintained to avoid unknown routines within the operating system (DOS), such as disk I/O that can be very time-consuming.

**NOTE:**

When exiting a program it is necessary to disable the Watchdog Timer, otherwise the system resets.

Example program:

```
; INITIAL TIMER PERIOD COUNTER
```

```
;
```

```
W_LOOP:
```

```
    MOV    AX, 6F02H    ;setting the time-out value
    MOV    BL, 30      ;time-out value is 48 seconds
    INT    15H
```

```
;
```

```
; ADD THE APPLICATION PROGRAM HERE
```

```
;
```

```
    CMP    EXIT_AP, 1    ;is the application over?
    JNE    W_LOOP      ;No, restart the application
```

```
    MOV    AX, 6F02H    ;disable Watchdog Timer
    MOV    BL, 0        ;
    INT    15H
```

```
;
```

```
; EXIT ;
```

Appendix

E

Address Mapping

E.1 I/O Address Map

Input/output (IO)	
[00000000 - 0000000F]	Direct memory access controller
[00000000 - 00000CF7]	PCI bus
[00000010 - 0000001F]	Motherboard resources
[00000020 - 00000021]	Programmable interrupt controller
[00000022 - 0000003F]	Motherboard resources
[00000040 - 00000043]	System timer
[00000044 - 0000005F]	Motherboard resources
[00000061 - 00000061]	System speaker
[00000063 - 00000063]	Motherboard resources
[00000065 - 00000065]	Motherboard resources
[00000067 - 0000006F]	Motherboard resources
[00000070 - 00000071]	System CMOS/real time clock
[00000072 - 0000007F]	Motherboard resources
[00000080 - 00000080]	Motherboard resources
[00000081 - 00000083]	Direct memory access controller
[00000084 - 00000086]	Motherboard resources
[00000087 - 00000087]	Direct memory access controller
[00000088 - 00000088]	Motherboard resources
[00000089 - 0000008B]	Direct memory access controller
[0000008C - 0000008E]	Motherboard resources
[0000008F - 0000008F]	Direct memory access controller
[00000090 - 0000009F]	Motherboard resources
[000000A0 - 000000A1]	Programmable interrupt controller
[000000A2 - 000000BF]	Motherboard resources
[000000C0 - 000000DF]	Direct memory access controller
[000000E0 - 000000EF]	Motherboard resources
[000000F0 - 000000FF]	Numeric data processor
[00000170 - 00000177]	Secondary IDE Channel























































	[000001F0 - 000001F7]	Primary IDE Channel
	[00000274 - 00000277]	ISAPNP Read Data Port
	[00000279 - 00000279]	ISAPNP Read Data Port
	[000002E8 - 000002EF]	Communications Port (COM4)
	[000002F8 - 000002FF]	Communications Port (COM2)
	[00000376 - 00000376]	Secondary IDE Channel
	[00000378 - 0000037F]	Printer Port (LPT1)
	[000003B0 - 000003BB]	Mobile Intel(R) 945 Express Chipset Family
	[000003C0 - 000003DF]	Mobile Intel(R) 945 Express Chipset Family
	[000003E8 - 000003EF]	Communications Port (COM3)
	[000003F6 - 000003F6]	Primary IDE Channel
	[000003F8 - 000003FF]	Communications Port (COM1)
	[00000400 - 0000041F]	Intel(R) 82801G (ICH7 Family) SMBus Controller - 27DA
	[00000480 - 000004BF]	Motherboard resources
	[000004D0 - 000004D1]	Motherboard resources
	[00000800 - 0000087F]	Motherboard resources
	[00000A00 - 00000A0F]	Motherboard resources
	[00000A10 - 00000A1F]	Motherboard resources
	[00000A20 - 00000A2F]	Motherboard resources
	[00000A30 - 00000A3F]	Motherboard resources
	[00000A60 - 00000A6F]	Motherboard resources
	[00000A79 - 00000A79]	ISAPNP Read Data Port
	[00000D00 - 0000FFFF]	PCI bus
	[0000C480 - 0000C49F]	Intel(R) 82801G (ICH7 Family) USB Universal Host Controller - 27CB
	[0000C800 - 0000C81F]	Intel(R) 82801G (ICH7 Family) USB Universal Host Controller - 27CA
	[0000C880 - 0000C89F]	Intel(R) 82801G (ICH7 Family) USB Universal Host Controller - 27C9
	[0000CC00 - 0000CC1F]	Intel(R) 82801G (ICH7 Family) USB Universal Host Controller - 27C8
	[0000CC80 - 0000CC87]	Mobile Intel(R) 945 Express Chipset Family
	[0000D000 - 0000DFFF]	Intel(R) 82801G (ICH7 Family) PCI Express Root Port - 27D0
	[0000DC00 - 0000DCFF]	Realtek RTL8168C(P)/8111C(P) PCI-E Gigabit Ethernet NIC #2
	[0000E000 - 0000EFFF]	Intel(R) 82801G (ICH7 Family) PCI Express Root Port - 27D2
	[0000EC00 - 0000ECFF]	Realtek RTL8168C(P)/8111C(P) PCI-E Gigabit Ethernet NIC
	[0000FFA0 - 0000FFAF]	Intel(R) 82801GBM/GHM (ICH7-M Family) Serial ATA Storage Controller

Table E-1: IO Address Map

E.2 IRQ Address Map

 Interrupt request (IRQ)

	(ISA) 0	System timer
	(ISA) 3	Communications Port (COM2)
	(ISA) 4	Communications Port (COM1)
	(ISA) 8	System CMOS/real time clock
	(ISA) 9	Microsoft ACPI-Compliant System
	(ISA) 10	Communications Port (COM4)
	(ISA) 11	Communications Port (COM3)
	(ISA) 13	Numeric data processor
	(ISA) 14	Primary IDE Channel
	(ISA) 15	Secondary IDE Channel
	(PCI) 5	Intel(R) 82801G (ICH7 Family) SMBus Controller - 27DA
	(PCI) 16	Intel(R) 82801G (ICH7 Family) PCI Express Root Port - 27D0
	(PCI) 16	Intel(R) 82801G (ICH7 Family) USB Universal Host Controller - 27CB
	(PCI) 16	Mobile Intel(R) 945 Express Chipset Family
	(PCI) 16	Realtek RTL8168C(P)/8111C(P) PCI-E Gigabit Ethernet NIC #2
	(PCI) 17	Intel(R) 82801G (ICH7 Family) PCI Express Root Port - 27D2
	(PCI) 17	Realtek RTL8168C(P)/8111C(P) PCI-E Gigabit Ethernet NIC
	(PCI) 18	Intel(R) 82801G (ICH7 Family) USB Universal Host Controller - 27CA
	(PCI) 19	Intel(R) 82801G (ICH7 Family) USB Universal Host Controller - 27C9
	(PCI) 23	Intel(R) 82801G (ICH7 Family) USB Universal Host Controller - 27C8
	(PCI) 23	Intel(R) 82801G (ICH7 Family) USB2 Enhanced Host Controller - 27CC

.....

Table E-2: IRQ Address Map

E.3 Memory Address Map

Memory Address Range	Device
[00000000 - 0009FFFF]	System board
[000A0000 - 000BFFFF]	Mobile Intel(R) 945 Express Chipset Family
[000A0000 - 000BFFFF]	PCI bus
[000C0000 - 000CFFFF]	System board
[000D0000 - 000DFFFF]	PCI bus
[000E0000 - 000FFFFF]	System board
[00100000 - 3F7FFFFF]	System board
[3F800000 - DFFFFFFF]	PCI bus
[D0000000 - DFFFFFFF]	Mobile Intel(R) 945 Express Chipset Family
[E0000000 - E3FFFFFF]	Motherboard resources
[E4000000 - FED8FFFF]	PCI bus
[FDE00000 - FDEFFFFFFF]	Intel(R) 82801G (ICH7 Family) PCI Express Root Port - 27D0
[FDEF0000 - FDEFFFFFFF]	Realtek RTL8168C(P)/8111C(P) PCI-E Gigabit Ethernet NIC #2
[FDF00000 - FDFFFFFFFF]	Intel(R) 82801G (ICH7 Family) PCI Express Root Port - 27D2
[FDFF0000 - FDFFFFFFFF]	Realtek RTL8168C(P)/8111C(P) PCI-E Gigabit Ethernet NIC
[FE880000 - FE8FFFFFFF]	Mobile Intel(R) 945 Express Chipset Family
[FE93BC00 - FE93BFFF]	Intel(R) 82801G (ICH7 Family) USB2 Enhanced Host Controller - 27CC
[FE940000 - FE97FFFF]	Mobile Intel(R) 945 Express Chipset Family
[FE980000 - FE9FFFFFFF]	Mobile Intel(R) 945 Express Chipset Family
[FEA00000 - FEAFFFFFFF]	Intel(R) 82801G (ICH7 Family) PCI Express Root Port - 27D0
[FEAFF000 - FEAFFFFFFF]	Realtek RTL8168C(P)/8111C(P) PCI-E Gigabit Ethernet NIC #2
[FEB00000 - FEBFFFFFFF]	Intel(R) 82801G (ICH7 Family) PCI Express Root Port - 27D2
[FEBFF000 - FEBFFFFFFF]	Realtek RTL8168C(P)/8111C(P) PCI-E Gigabit Ethernet NIC
[FEC00000 - FEC00FFF]	Motherboard resources
[FED13000 - FED19FFF]	System board
[FED1C000 - FED1FFFF]	Motherboard resources
[FED20000 - FED3FFFF]	Motherboard resources
[FED40000 - FED8FFFF]	Motherboard resources
[FED90000 - FFFFFFFF]	System board
[FEE00000 - FEE00FFF]	Motherboard resources

Table E-3: Memory Address Map

Appendix

F

Hazardous Materials Disclosure

F.1 Hazardous Material Disclosure Table for IPB Products Certified as RoHS Compliant Under 2002/95/EC Without Mercury

The details provided in this appendix are to ensure that the product is compliant with the Peoples Republic of China (China) RoHS standards. The table below acknowledges the presences of small quantities of certain materials in the product, and is applicable to China RoHS only.

A label will be placed on each product to indicate the estimated “Environmentally Friendly Use Period” (EFUP). This is an estimate of the number of years that these substances would “not leak out or undergo abrupt change.” This product may contain replaceable sub-assemblies/components which have a shorter EFUP such as batteries and lamps. These components will be separately marked.

Please refer to the table on the next page.

Part Name	Toxic or Hazardous Substances and Elements					
	Lead (Pb)	Mercury (Hg)	Cadmium (Cd)	Hexavalent Chromium (CR(VI))	Polybrominated Biphenyls (PBB)	Polybrominated Diphenyl Ethers (PBDE)
Housing	X	O	O	O	O	X
Display	X	O	O	O	O	X
Printed Circuit Board	X	O	O	O	O	X
Metal Fasteners	X	O	O	O	O	O
Cable Assembly	X	O	O	O	O	X
Fan Assembly	X	O	O	O	O	X
Power Supply Assemblies	X	O	O	O	O	X
Battery	O	O	O	O	O	O

O: This toxic or hazardous substance is contained in all of the homogeneous materials for the part is below the limit requirement in SJ/T11363-2006

X: This toxic or hazardous substance is contained in at least one of the homogeneous materials for this part is above the limit requirement in SJ/T11363-2006

Index

+

+12V power source connector 4

5

5V power connector 4
location and pinouts 42

A

ACPI 130, 131, 132
airflow 88
anti-static precautions 34, 74
 anti-static pad 34, 74
 anti-static wristband 34, 74
 handling 34, 74
 self-grounding 34, 74
ASKIR interface 54
AT power cable 90
AT power connector 43
 location and pinouts 43
AT power select jumper 44, 80
 location 81
 settings 80
ATA flat cable 91, 93, 94
ATX power control connector 4
ATX power supply enable connector 44
 location and pinouts 44
Audio Codec '97 19
audio connector 4, 45
 location and pinouts 45

B

backlight inverter connector 4, 46
 location and pinouts 46
BIOS 27, 109, 110, 111, 112, 113, 114,
115, 116, 117, 122, 126, 127, 130, 131,
132, 133, 135, 136, 138, 139, 140, 141,
142, 144, 145, 146, 147, 148, 149, 150,
153, 154, 155
BIOS chipset 27

C

cables 89
 AT power 90
 ATA flat cable 94
 dual port USB 98
 four serial port 101
 LPT 99
 parallel port 99
 SATA drive 95
 SATA drive power 95
 single RS-232 97
CF card 47, 78
 installation 78
 location and pinouts 47
 setup jumper 81
 socket 47
CF card setup jumper 5, 81
 location 82
 settings 81
chassis 88
 installation 88

Ethernet controllers	69
external indicators	51
external peripheral interface	102
connection	102
connectors	102
External Peripheral Interface Connectors	
Keyboard/Mouse	68
external switches	51

F

fan connector	4, 50
location and pinouts	50
fan speed controller	29
FDD	122
four serial port cable	101
front panel connector	4, 51
location and pinouts	51
FSB	114

H

hard disk drives	
SATA	63

I

IDE connector, 40-pin	4
IDE connector, 44-pin	52
location and pinouts	52
IDE device	91, 92, 93, 94
ATA flat cable	91, 93, 94
connector	92, 93, 94
IDE interface	19
infrared interface	54
Amplitude Shift Key Infrared	54

ASKIR	54
Serial Infrared	54
SIR	54
infrared interface connector	4, 54
location and pinouts	54
installation checklist	76
IrDA	124, 125
IrDA connector	4

J

jumper	
RS-232/422/485 COM2 setup	5
jumper	79
AT power select	44, 80
CF card setup	81
clear CMOS	82
COM 2 function select	83
jumper configuration	79
jumper settings	79
LVDS voltage selection	86
LVDS1 Panel Resolution	84
PCI-104 Voltage Setup	87

K

keyboard	55
keyboard connector	4
keyboard controller	30
keyboard/mouse connector	55
location and pinouts	55

L

LAN connection	103
LAN connector	69

LCD display	46
backlight inverter connector	46
LPC bus	27
LPC interface	21, 29
LPT	
cable connection	100
LPT cable	99
LPT connection	99
LVDS connector	4
LVDS display	86
voltage select	86
LVDS LCD connector	56
location and pinouts	56
LVDS panel	56
18-bit	56
36-bit	56
dual channel	56
single channel	56
LVDS voltage selection jumper	86
location	86
settings	86
LVDS1 Panel Resolution jumper	84
LVDS1 panel resolution selection jumper	5
LVDS1 voltage selection jumper	5
LVDS2 voltage selection jumper	5

M

memory module installation	77
motherboard	89
installation	89
mouse	55

N

northbridge chipset	14
---------------------	----

P

parallel port	
cable connection	100
parallel port	123
parallel port cable	99
parallel port connection	99
parallel port connector	57
location and pinouts	57
parallel port connector	4
PC104+ VIO selector jumper	5
PCI interface	21
PCI-104 slot	5, 60
location and pinouts	60
PCI-104 Voltage Setup jumper	87
PCIe mini card slot	58, 59
location and pinouts	59
PCIe Mini Card slot	5
peripheral connectors	42
peripheral device cables	89
Power Button Mode	133
power supply	43, 44
AT power select jumper	80
AT power supply	43, 44
ATX power supply	44
PS/2 cable	55
PS/2 connector	5
PS/2 keyboard and mouse connection	103

R

RAID	63
real time clock	25
RJ-45 connection	103
single connector	103
RJ-45 connector	69
RJ-45 connector	69
RJ-45 Ethernet connector	5
RJ-45 LAN connector	69
RS-232	64, 65, 70, 97
cable connection	97
COM 1 location and pinouts	70
COM 2 location and pinouts	64, 65
COM 3 location and pinouts	65
COM 4 location and pinouts	65
connector location and pinouts	64, 65, 70
serial port devices	64
single cable	97
RS-232 serial port connector	5
RS-232 serial port devices	64
RS-232/422/485 serial port connector	5
RS-422	65
COM 2 location and pinouts	65
RS-485	65
COM 2 location and pinouts	65

S

SATA	
controller	25
SATA drive	95
cables	95
connection	95

power cable	95
SATA drive connector	5, 63
location and pinouts	63
SATA drives	63
Serial Device	
connection	104
serial port	70
serial port connector	64, 65, 70
location and pinouts	64, 65, 70
serial ports	29
SIR interface	54
SODIMM	77
installation	77
specifications	77
Super I/O chipset	28
system voltages	126, 130

T

technical specifications	5
temperature	126
TV out connector	66
location and pinouts	66
TV Out connector	5

U

unpacking	34
unpacking checklist	35
unpacking precautions	34
USB	66, 67, 98, 139, 140, 141
cable	
dual port	98
cable	98
cable connection	99
connectors	98

controller	26	USB2.0	140, 141
devices	67		
external USB device connection	105	V	
port	67	VGA	106
USB 1.1	67	VGA connector	71
USB 2.0	67	VGA monitor	106
USB 1.1	67	connection	106
USB 2.0	67, 140		
USB 2.0 port	71	W	
USB cable			
dual port	98		
USB connector, internal	5, 67		
location and pinouts	67		
USB device connection	105	Y-cable	55
dual connector	105		
USB port	71		

Any advice or comments about our products and service, or anything we can help you with please don't hesitate to contact with us. We will do our best to support your products, projects and business.



Address: Global American, Inc.
17 Hampshire Drive
Hudson, NH 03051

Telephone: Toll Free U.S. Only (800) 833-8999
(603) 886-3900

FAX: (603) 886-4545

Website: <http://www.globalamericaninc.com>

Support: Technical Support at Global American
