



integration with integrity

3308530 User's Manual

3.5" Embedded Controller with Socket P

Version 1.0



Copyrights

This document is copyrighted and all rights are reserved. It does not allow any non authorization in copied, photocopied, translated or reproduced to any electronic or machine readable form in whole or in part without prior written consent from the manufacturer.

In general, the manufacturer will not be liable for any direct, indirect, special, incidental or consequential damages arising from the use of inability to use the product or documentation, even if advised of the possibility of such damages. The manufacturer keeps the rights in the subject to change the contents of this document without prior notices in order to improve the function design, performance, quality and reliability. The author assumes no responsibility for any errors or omissions, which may appear in this document, nor does it make a commitment to update the information contained herein.

Trademarks

Intel is a registered trademark of Intel Corporation.
Award is a registered trademark of Award Software, Inc.

All other trademarks, products and or product's name mentioned herein are mentioned for identification purposes only, and may be trademarks and/or registered trademarks of their respective companies or owners.

Packing List:

Please check the package content before you starting using the board.

Hardware:

3308530 3.5" Miniboard x 1

Cable Kit:



DC Power Cable x 1



SATA Cable x 2



PS/2 cable x 1(keyboard & mouse)



COM Port Cable x 1



Audio Port Cable x 1

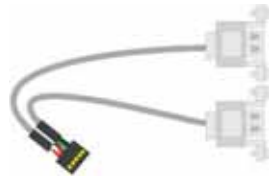

USB Cable x 1



1 to 3 power output cable x 1



SATA power Cable x 1



CPU Cooler x 1

Printed Matters:

Driver CD x 1 (Including User's Manual)

Index

Chapter 1 <Introduction>	7
1.1 <Product Overview>	7
1.2 <Product Specification>.....	8
1.3 <Mechanical Drawing_top>.....	9
1.4 <Block Diagram>.....	11
Chapter 2 <Hardware Setup>	12
2.1 <Connector Location>	12
2.2 <Jumper Location & Reference>	14
2.3 <Connector Reference>	16
2.3.1 <Internal Connectors>	16
2.3.2 <External Connectors>	16
2.4 <CPU and Memory Setup>.....	17
2.4.1 <CPU Setup>.....	17
2.4.2 <Memory Setup>.....	18
2.5 <CMOS Setup>.....	19
2.6 <Serial ATA Interface>.....	20
2.7 <Ethernet Interface>.....	21
2.8 <Onboard Display Interface>.....	22
2.8.1 <Analog Display>.....	22
2.8.2 <Digital Display>	23
2.8.3 <HDTV Interface>.....	27
2.9 <Integrated Audio Interface>	28
2.10 <GPIO Interface>.....	30
2.11 <Power Supply>.....	31
2.11.1 <Power Input>.....	31
2.12 <Switch and Indicator>	32
Chapter 3 <System Setup>	33
3.1 <Audio Configuration>.....	33
3.2 <Display Properties Setting>	34

Appendix A <I/O Port Pin Assignment>	38
A.1 <Serial ATA Port>	38
A.2 <IrDA Port>	38
A.3 <Serial Port 1>	39
A.4 <Serial Port 2>	39
A.5 <VGA Port>	41
A.6 <LAN Port>	41
A.7 <USB Interface>	41
Appendix B <Flash BIOS>	42
B.1 <Flash Tool>	42
B.2 <Flash BIOS Procedure>	42
Appendix C <System Resources>	43
Appendix D <Programming GPIO's>	47
Appendix E <Programming Watchdog Timer> ...	48
Contact Information	49

(This page is left for blank)

Chapter 1 <Introduction>

1.1 <Product Overview>

3308530, the new generation of the 3.5" Miniboard, supports Intel Penryn Processors for 667/800/1066 MHz front side bus and features Intel GM45 and ICH9M chipset, integrated GMA X4500 graphics, One DDR3 SO-DIMM memory, REALTEK High Definition Audio, two Serial ATA and two Intel Gigabit LAN.

Intel Penryn Processor

The board supports Intel Penryn Processors with 667/800/1066 MHz front side bus, L2 Cache: All specification depend on the CPU (1M/2M/3M/4M/6M), to provide more powerful performance than before.

New features for Intel GM45 chipset

The board integrates Intel GM45 and ICH9M chipset, to provide new generation of the mobile solution, supports Intel GMA X4500 graphics, One DDR3 SO-DIMM 800/1066 MHz memory, built-in high speed mass storage interface of serial ATA, High Definition Audio with 2 channels surrounding sound.

All in One multimedia solution

Based on Intel GM45 and ICH9M chipset, the board provides high performance onboard graphics, 24-bit dual channel LVDS interface, HDTV and 2 channels High Definition Audio, to meet the very requirement of the multimedia application.

Flexible Extension Interface

The board provides one PCI Express Mini Card and one Mini PCI socket.

1.2 <Product Specification>

General Specification

Form Factor	3.5" Miniboard
CPU	Support Intel Core 2 Duo Processor Package type: Micro-FCPGA478 Front side bus: 667/800/1066 MHz L2 Cache: All specification depend on the CPU. (1M/2M/3M/4M/6M)
Memory	One DDRIII 800/1066MHz up to 2GB Non-ECC, unbuffered memory supported only
Chipset	Intel GM45 & ICH9M
Real Time Clock	Chipset integrated RTC with onboard lithium battery
Watchdog Timer	Generates a system reset with internal timer for 1min/s ~255min/s
Power Management	ACPI 2.0 compliant, supports power saving mode
Serial ATA Interface	2 x serial ATAll interface with 300MB/s transfer rate
VGA Interface	Intel integrated extreme GMA X4500 (Graphic Media Accelerator) Technology
LVDS interface	Onboard 24-bit dual channel LVDS connector with +3.3V/+5V/+12V supply
Audio Interface	Intel integrated ICH9M with Realtek ALC888 HD Audio
LAN Interface	2 x Intel 82574L Gigabit LAN
GPIO interface	Onboard programmable 8-bit Digital I/O interface
Extended Interface	1 x PCI Express mini card, 1 x Mini PCI socket to support Mini PCI Type III B
Internal I/O Port	1 x RS232/422/485, 1 x SMBUS, 1 x GPIO port, 1 x HDTV, 4 x USB ports, 1 x IrDA, 2 x Serial ATA, 1x LVDS, 1x LCD inverter connector, 1 x Audio connector and 1 x CDIN connector
External I/O Port	1 x PS/2 Keyboard/Mouse Port, 2 x RJ45 LAN ports, 1 x DB15 VGA port, 1 x RS232 port and 1 x SPDIF connector
Power Requirement	12V DC Input
Dimension	146mm x 101mm
Temperature	Operating within 0~60 centigrade Storage within -20~85 centigrade

Ordering Code

3308530	Onboard VGA, LVDS, LAN, USB2.0, HD Audio, SATA, HDTV, SMBUS, Mini PCI socket and PCI Express mini card
---------	--

1.3 <Mechanical Drawing_top>

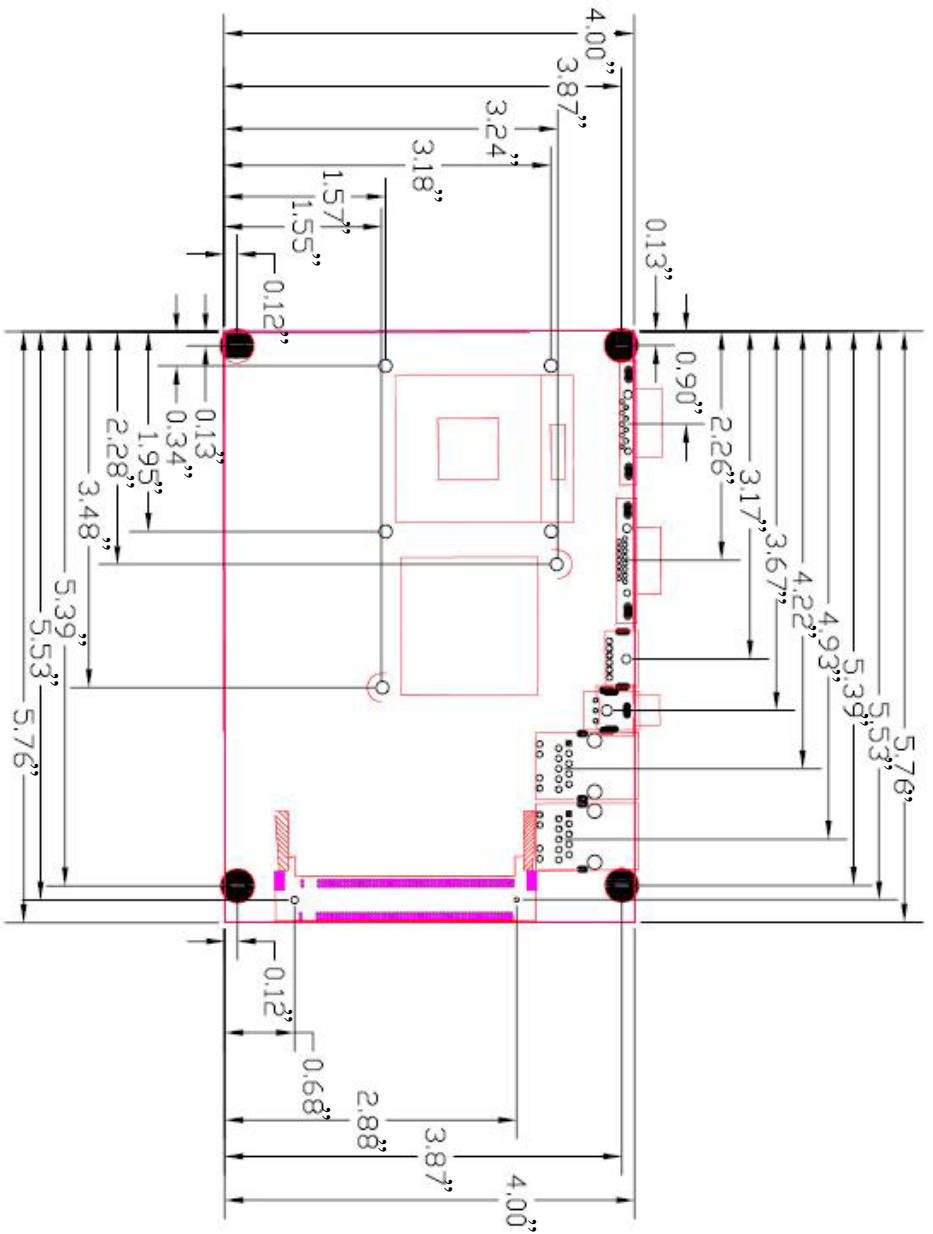

<Mechanical Drawing_bot>

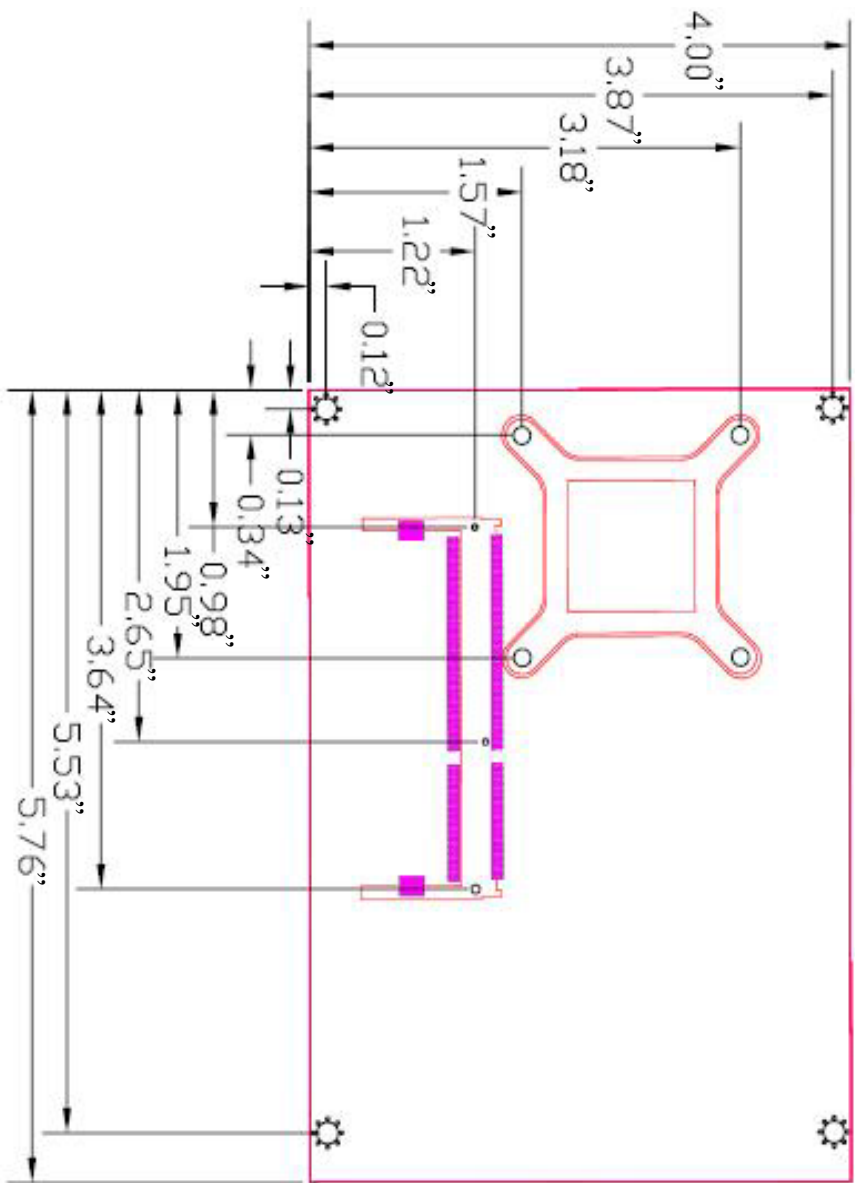

1.4 <Block Diagram>

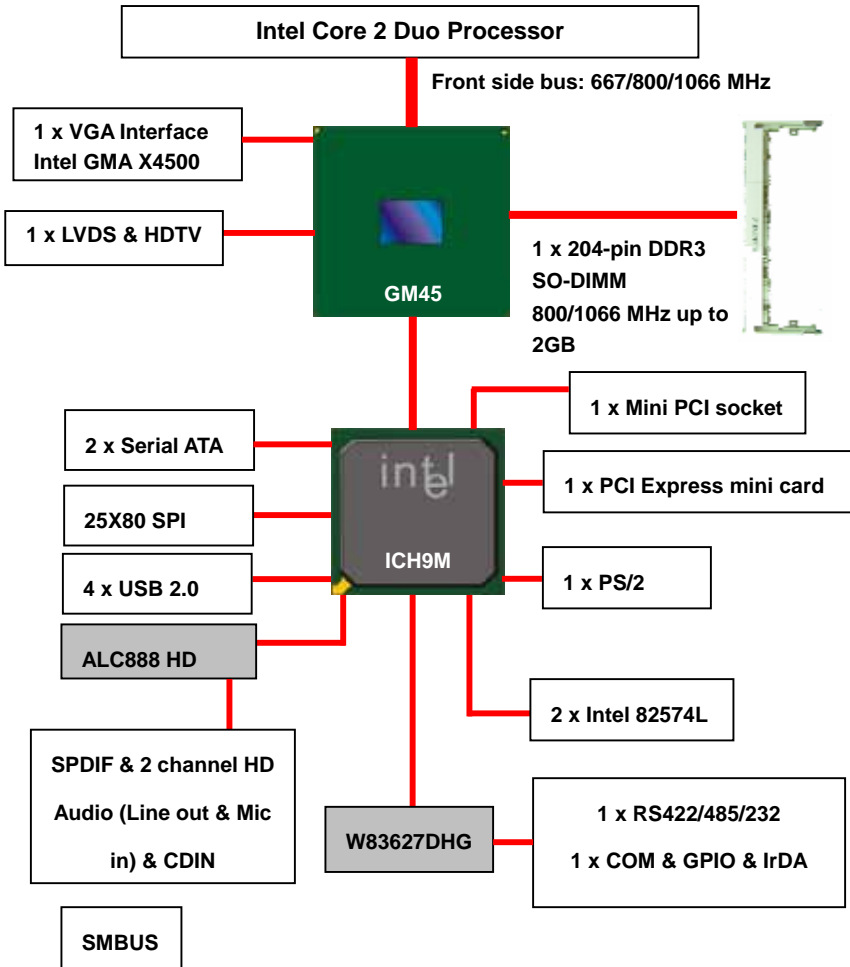

Chapter 2 <Hardware Setup>

2.1 <Connector Location>

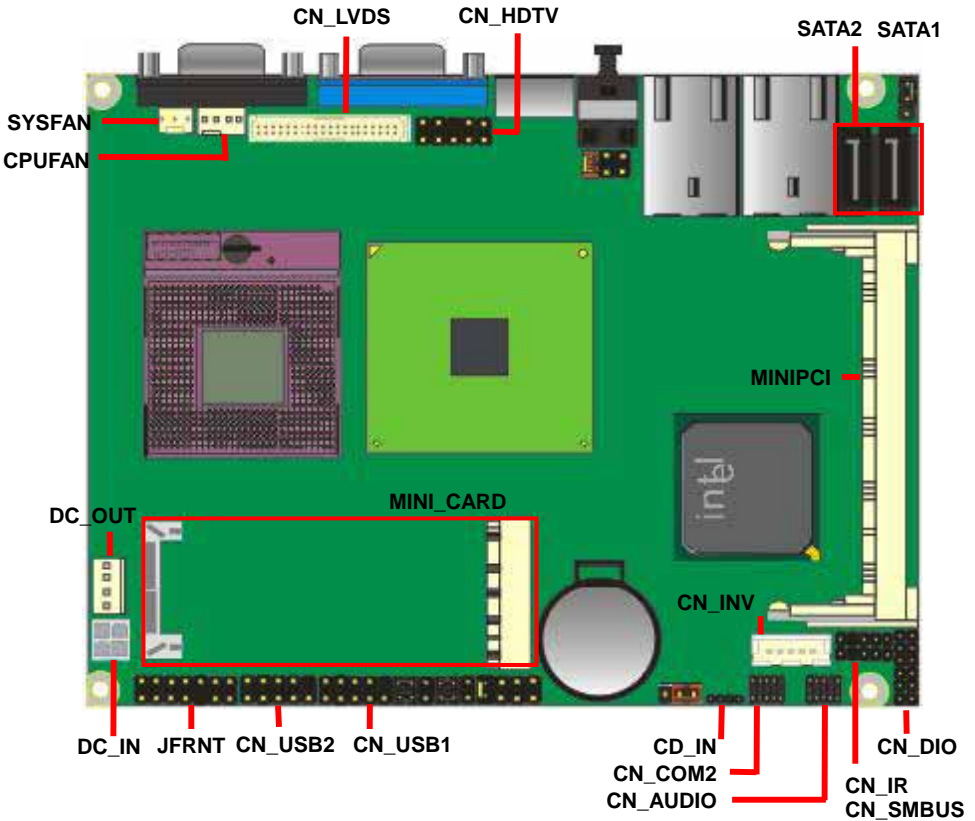

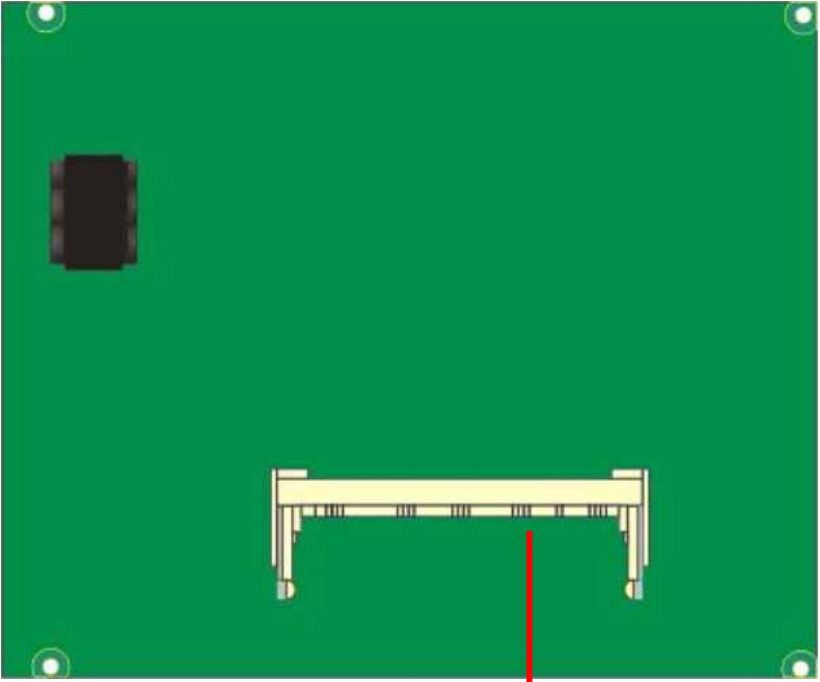

SO-DIMM

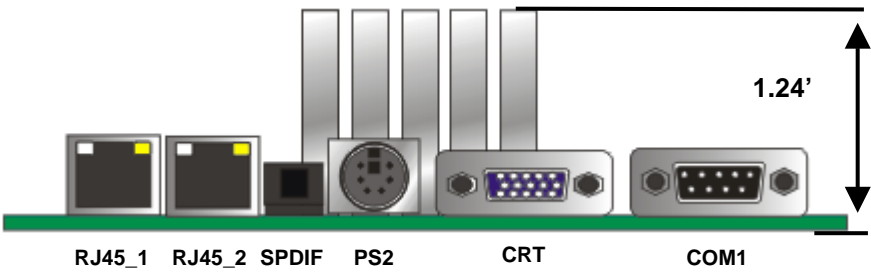

2.2 <Jumper Location & Reference>

Jumper	Function
JRTC	CMOS Operating/Clear Setting
JVLCD	Panel Voltage Setting
JAT	Power mode select
JCSEL1 JCSEL2	CN_COM2 RS-232 RS422 RS485 Setting / CN_IR IrDA Setting

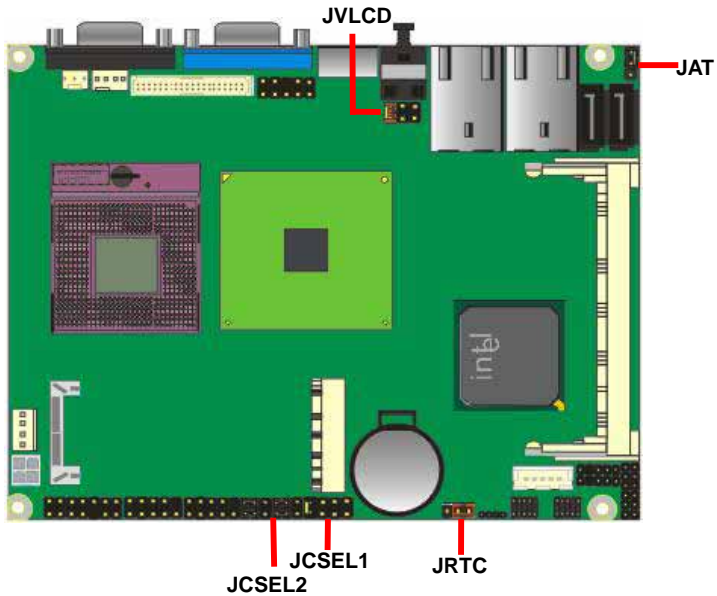

Jumper: **JAT**

Type: onboard 3-pin header

Power Mode	JAT
AT Mode	1-2
ATX Mode	2-3
Default setting: ATX Mode	
	

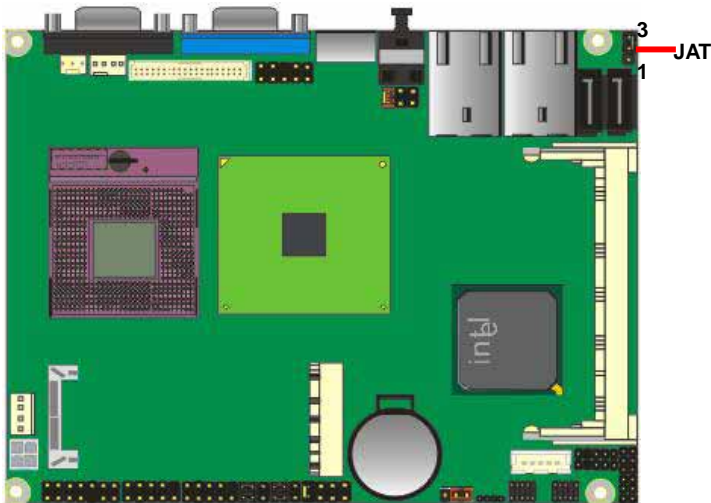

2.3 <Connector Reference>

2.3.1 <Internal Connectors>

Connector	Function	Remark
CPU	Socket 478 for socket-P CPU	
SO-DIMM	204-pin DDR3 SO-DIMM socket	
SATA1/2	7-pin Serial ATA connector	
DC_IN	DC 12V input connector	
CN_AUDIO	5 x 2-pin audio connector	
CD_IN	4-pin CD-ROM audio input connector	
CN_DIO	6 x 2-pin digital I/O connector	
CN_USB1/2	5 x 2-pin USB connector	
CPUFAN	4-pin CPU cooler fan connector	
SYSFAN	3-pin system cooler fan connector	
CN_HDTV	5 x 2-pin HDTV interface	
CN_LVDS	20 x 2-pin LVDS connector	
CN_INV	5-pin LCD inverter connector	
CN_IR	5-pin IrDA connector	
JFRNT	14-pin front panel switch/indicator connector	
MINIPCI	124-pin Mini PCI socket Type IIIA	
MINI_CARD	52-pin PCI Express mini card	
CN_COM2	9-pin RS422/485/232	
JAT	Power mode select	
JCSEL1	CN_COM2 RS-232 RS422 RS485 Setting /	
JCSEL2	CN_IR IrDA Setting	
JRTC	CMOS Operating/Clear Setting	

2.3.2 <External Connectors>

Connector	Function	Remark
RJ45_1/2	Two RJ45 LAN Ports	
SPDIF	SPDIF digital audio output Port	
PS2	PS/2 keyboard and mouse Port	
CRT	Analog DB15 VGA Port	
COM1	DB9 RS232 COM Port	

2.4 <CPU and Memory Setup>

2.4.1 <CPU Setup>

The board comes with the socket 478 for Intel Core 2 Duo **socket-P** Processor 667/800/1066 MHz of front side bus and L2 Cache: All specification depend on the CPU (1M/2M/3M/4M/6M). Please follow the instruction to install the CPU properly.

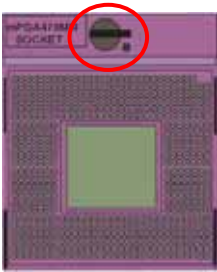

1. Use the flat-type screw drive to unlock the CPU socket

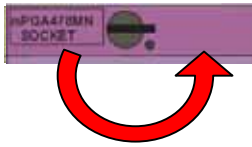

Unlock way

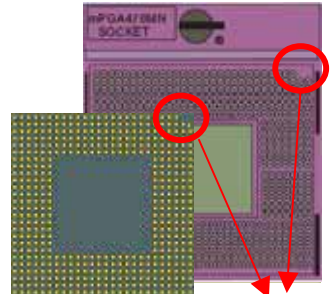

Check point

2. Follow the pin direction to install the processor on the socket



3. Lock the socket

4. Socket P has 478 pins, but is not pin-compatible with Socket M CPU.

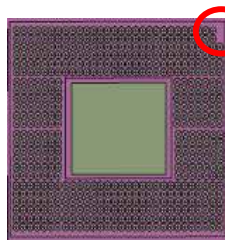

Socket-M CPU
Check point

2.4.2 <Memory Setup>

The board provides one 204-pin DDR3 SO-DIMM to support 800/1066MHz DDR3 SO-DIMM memory module up to 2GB.

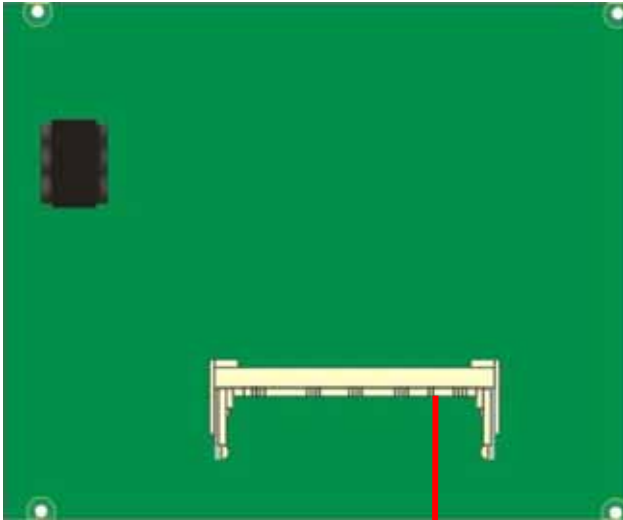

SO-DIMM

2.5 <CMOS Setup>

The board's data of CMOS can be setting in BIOS. If the board refuses to boot due to inappropriate CMOS settings, here is how to proceed to clear (reset) the CMOS to its default values.

Jumper: JRTC

Type: Onboard 3-pin jumper

JRTC	Mode
1-2	Clear CMOS
2-3	Normal Operation

Default setting: 2-3

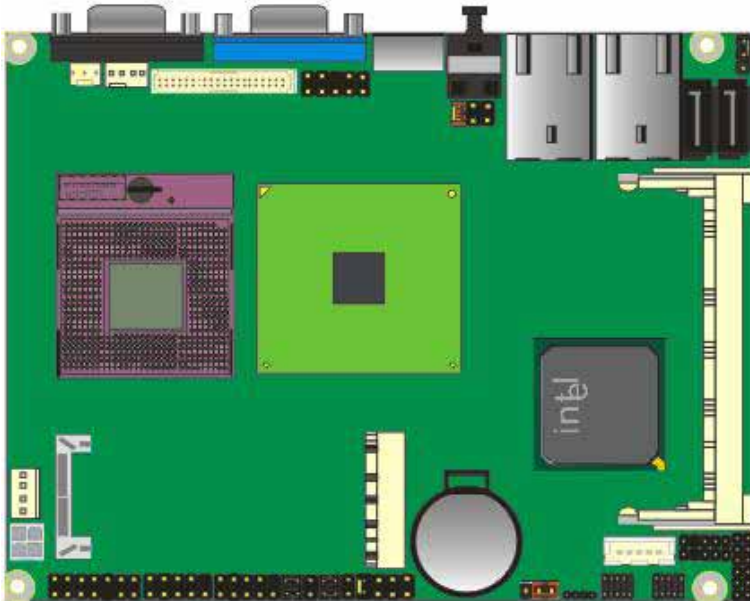

1 3
JRTC

2.6 <Serial ATA Interface>

Based on Intel ICH9M, the board provides two Serial ATAII interfaces with up to 300MB/s of transfer rate.

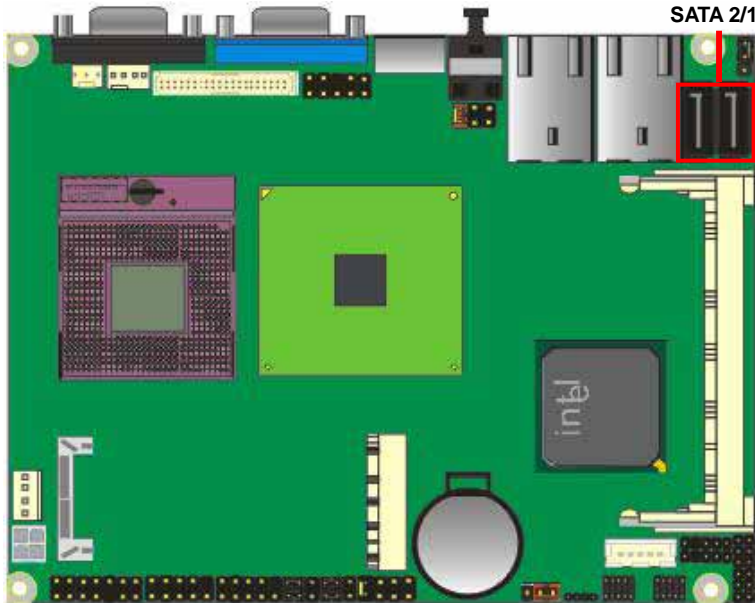

2.7 <Ethernet Interface>

The board integrates with two Intel 82574L Gigabit Ethernet controllers. The Intel Gigabit Ethernet supports triple speed of 10/100/1000Base-T, with IEEE802.3 compliance and Wake-On-LAN supported.

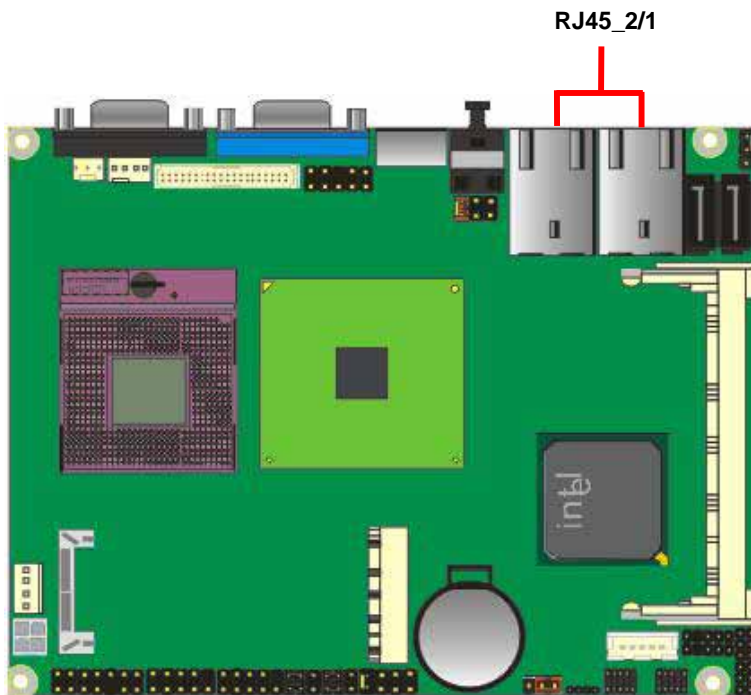

2.8 <Onboard Display Interface>

Based on Intel GM45 chipset with built-in GMA (Graphic Media Accelerator) X4500 graphics, the board provides one DB15 connector on rear external I/O port, and one 40-pin LVDS interface with 5-pin LCD backlight inverter connector. The board provides dual display function with clone mode and extended desktop mode for VGA, LVDS, and HDTV.

2.8.1 <Analog Display>

Please connect your CRT or LCD monitor with DB15 male connector to the onboard DB15 VGA female connector on rear I/O port.

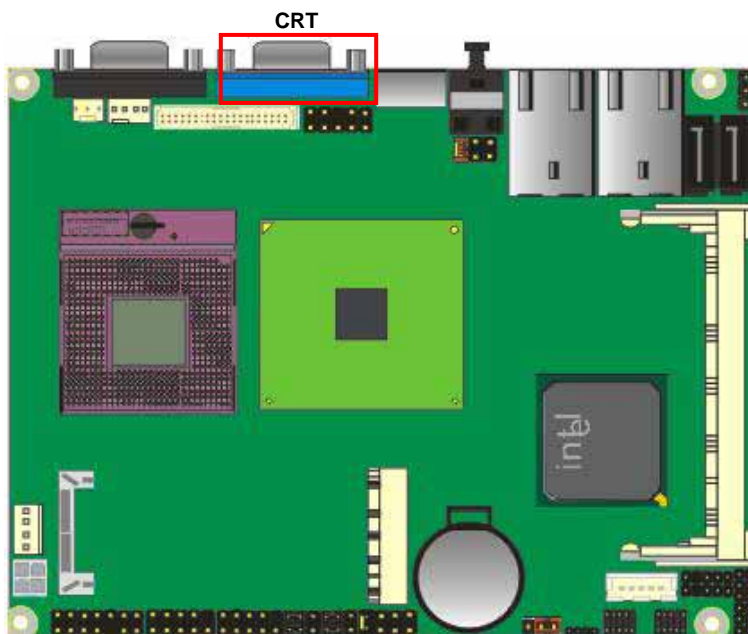

2.8.2 <Digital Display>

The board provides one 40-pin LVDS connector for 18/24-bit single/dual channel panels, supports up to 1920 x 1200 (UXGA) resolution, with one LCD backlight inverter connector and one jumper for panel voltage setting.

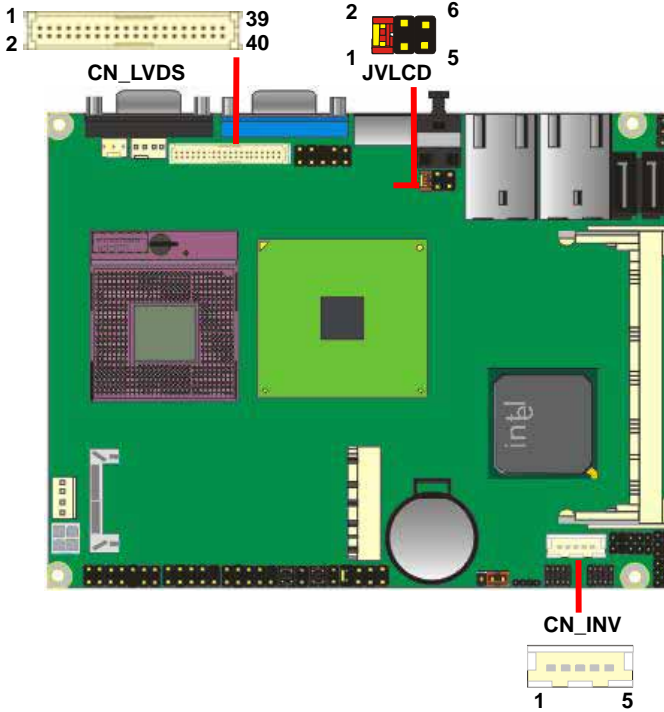

Effective patterns of connection: 1-2 / 3-4 / 5-6



Warning: others cause damages

Connector: **CN_INV**

Type: 5-pin LVDS Power Header

Pin	Description
1	+12V
2	CTLBKL
3	GND
4	GND
5	ENABKL

Connector: **JVLCD**

Type: 6-pin Power select Header

Pin	Description
1-2	LCDVCC (3.3V)
3-4	LCDVCC (5V)
5-6	LCDVCC (12V)

Default: 1-2

Connector: **CN_LVDS**

Type: onboard 40-pin connector for LVDS connector

Connector model: **HIROSE DF13-40DP-1.25V**

Pin	Signal	Pin	Signal
2	LCDVCC	1	LCDVCC
4	GND	3	GND
6	ATX0-	5	BTX0-
8	ATX0+	7	BTX0+
10	GND	9	GND
12	ATX1-	11	BTX1-
14	ATX1+	13	BTX1+
16	GND	15	GND
18	ATX2-	17	BTX2-
20	ATX2+	19	BTX2+
22	GND	21	GND
24	ACLK-	23	BTX3-
26	ACLK+	25	BTX3+
28	GND	27	GND
30	ATX3-	29	BCLK-
32	ATX3+	31	BCLK+
34	GND	33	GND
36	DDCPCLK	35	N/C
38	DDCPDATA	37	N/C
40	N/C	39	N/C

To setup the LCD, you need the component below:

1. A panel with LVDS interfaces.
2. An inverter for panel's backlight power.
3. A LCD cable and an inverter cable.

For the cables, please follow the pin assignment of the connector to make a cable, because every panel has its own pin assignment, so we do not provide a standard cable; please find a local cable manufacture to make cables.

LCD Installation Guide:

1. Preparing the 3308530, LCD panel and the backlight inverter.

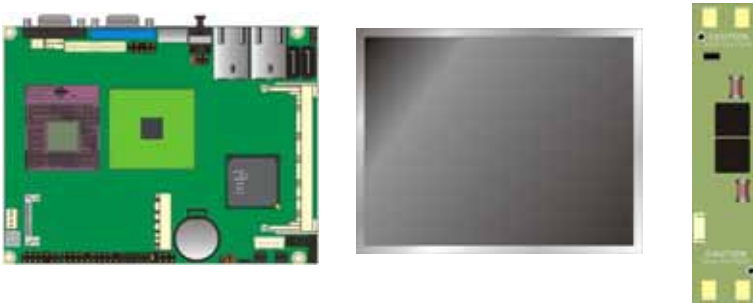

2. Please check the datasheet of the panel to see the voltage of the panel, and set the jumper **JVLCD** to +12V or +5V or +3.3V.
3. You would need a LVDS type cable.



4. To connect all of the devices well.

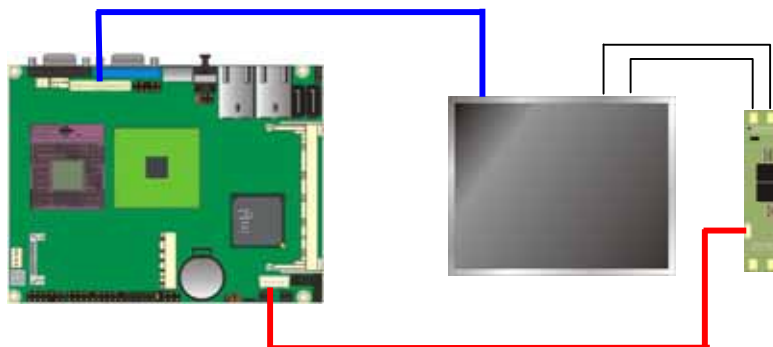

After setup the devices well, you need to select the LCD panel type in the BIOS.

The panel type mapping is list below:

BIOS panel type selection form (BIOS Version:1.0)			
18-bit Single channel		24-bit Dual channel	
NO.	Output format	NO.	Output format
1	640 x 480	1	1280 x 768
2	800 x 480	2	1280 x 1024
3	800 x 600	3	1600 x 1200
4	1024 x 768	4	1920 x 1080
5	1280 x 800	5	1920 x 1200
18-bit Dual channel			
1	1280 x 768		
24-bit Single channel			
1	1024 x 768		
2	1280 x 768		
3	1280 x 800		
4	1366 x 768		

2.8.3 <HDTV Interface>

The board provides HDTV interface with Intel GM45, support PAL and NTSC of TV system, and display (clone or extended desktop) function with CRT, LVDS.

Connector: **CN_HDTV**

Connector type: 10-pin header HDTV connector (pitch = 2.54mm)

Pin Number	Assignment	Pin Number	Assignment
1	GND	2	DACB_L
3	DACC_L	4	GND
5	GND	6	N/C
7	DACA_L	8	GND
9	N/C	10	N/C

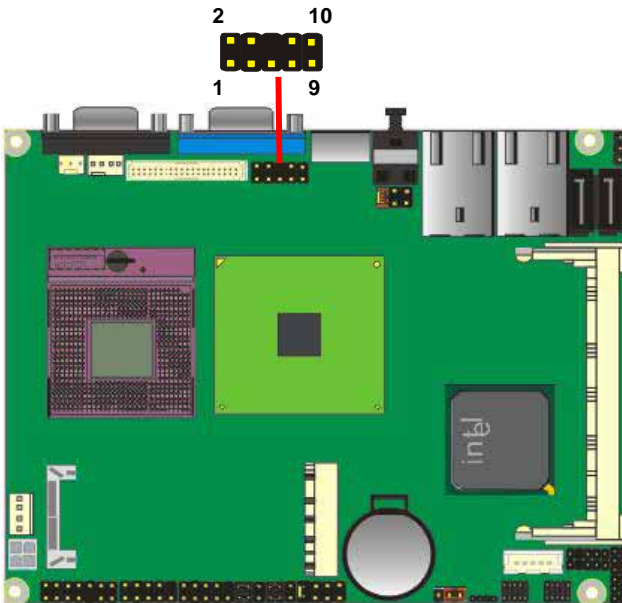

2.9 <Integrated Audio Interface>

The board integrates onboard audio interface with REALTEK ALC888 codec, with Intel next generation of audio standard as High Definition Audio, it offers more sound and other advantages than former AC'97 audio compliance.

The main specifications of ALC888 are:

- **High-performance DACs with 100dB S/N ratio**
- **3 DAC channels support 16/20/24-bit PCM format for 2 audio solution**
- **16/20/24-bit S/PDIF-OUT supports 44.1K/48K/96kHz sample rate**
- **Meets Microsoft WHQL/WLP 2.0 audio requirements**

The board provides 2 channels audio phone jacks on rear I/O port, and Line Out / Mic In ports for front I/O panel through optional cable.

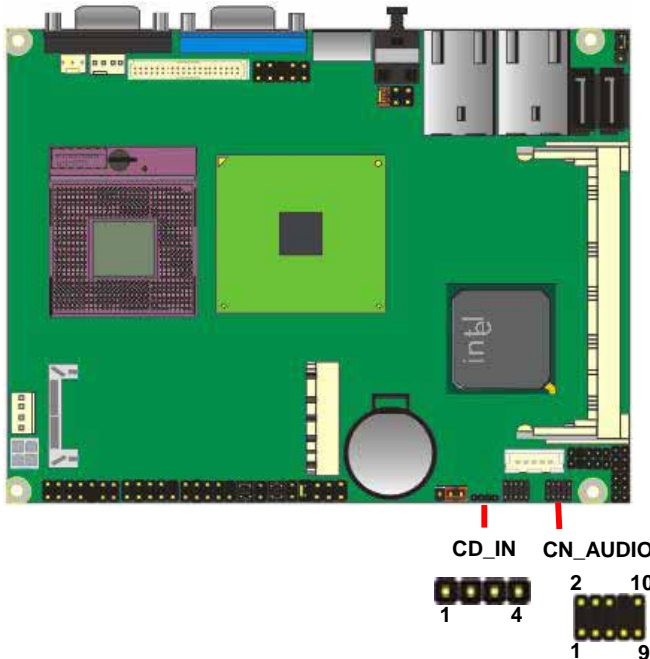

Connector: CN_AUDIO

Type: 10-pin (2 x 5) header (pitch = 2.54x1.27 mm)

Pin	Description	Pin	Description
1	MIC_L	2	Ground
3	MIC_R	4	Reserve
5	Speaker_R	6	MIC Detect
7	SENSE	8	N/C
9	Speaker_L	10	Speaker Detect

Connector: CD_IN

Type: 4-pin header (pitch = 2.54mm)

Pin	Description
1	CD – Left
2	Ground
3	Ground
4	CD – Right

2.10 <GPIO Interface>

The board provides a programmable 8-bit digital I/O interface; you can use this general purpose I/O port for system control like POS (Point-Of-Sale) or KIOSK (Public Information Booth).

Connector: **CN_DIO**

Type: 12-pin (6 x 2) header (pitch = 2.0mm)

Pin	Description	Pin	Description
1	Ground	2	Ground
3	GP10	4	GP14
5	GP11	6	GP15
7	GP12	8	GP16
9	GP13	10	GP17
11	VCC	12	+12V

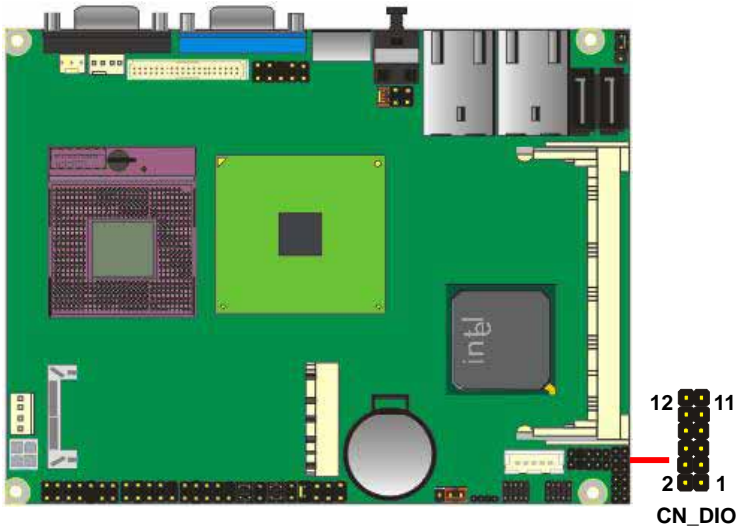

2.11 <Power Supply>

2.11.1 <Power Input>

The board requires onboard 4-pin DC-input connector **12V voltage**, for the input current, please take a reference of the power consumption report on appendix.

Connector: **DC_IN**

Type: 4-pin DC power connector

Pin	Description	Pin	Description
1	Ground	2	Ground
3	+12V	4	+12V

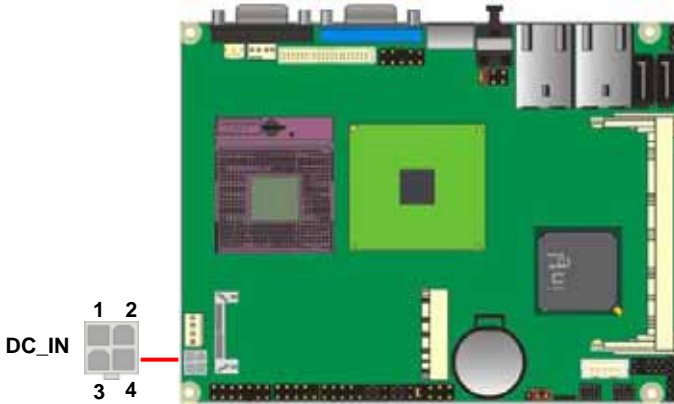

2.12 <Switch and Indicator>

The **JFRNT** provides front control panel of the board, such as power button, reset and beeper, etc. Please check well before you connecting the cables on the chassis.

Connector: **JFRNT**

Type: onboard 14-pin (2 x 7) 2.54-pitch header

Function	Signal	PIN		Signal	Function
IDE LED	HDLED+	1	2	PWRLED+	Power LED
	HDLED-	3	4	N/C	
Reset	Reset+	5	6	PWRLED-	Speaker
	Reset-	7	8	SPK+	
N/C		9	10	N/C	
Power Button	PWRBT-	11	12	N/C	
	PWRBT+	13	14	SPK-	

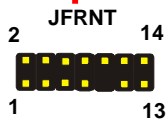
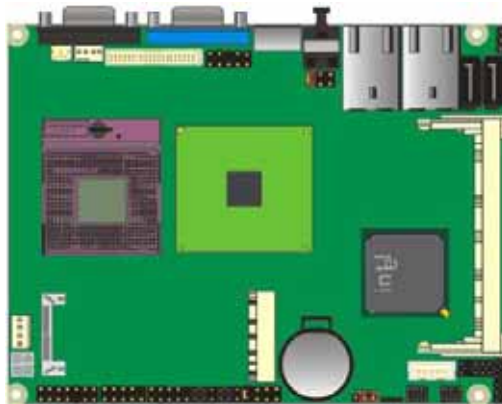

Chapter 3 <System Setup>

3.1 <Audio Configuration>

The board integrates Intel® ICH9M with REALTEK® ALC888 codec. It can support 2-channel sound under system configuration. Please follow the steps below to setup your sound system.

1. Install REALTEK HD Audio driver.
2. Launch the control panel and Sound Effect Manager.



3. Select Speaker Configuration



3.2 <Display Properties Setting>

Based on Intel GM45 GMCH with GMA X4500 (Graphic Media Accelerator), the board supports two DACs for display device as different resolution and color bit. Please install the Intel Graphic Driver before you starting setup display devices.

1. Click right button on the desktop to lunch **display properties**

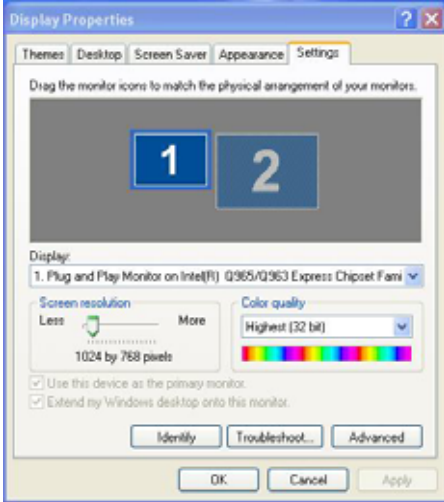

2. Click **Advanced** button for more specificity setup.



Click **Graphics Properties...** for advanced setup

3. This setup options can let you define each device settings.

Click **Monitor** to setup the CRT monitor for Colors, Resolution and Refresh Rate

Click **Intel(R) Dual Display Clone** to setup the dual display mode as same screen

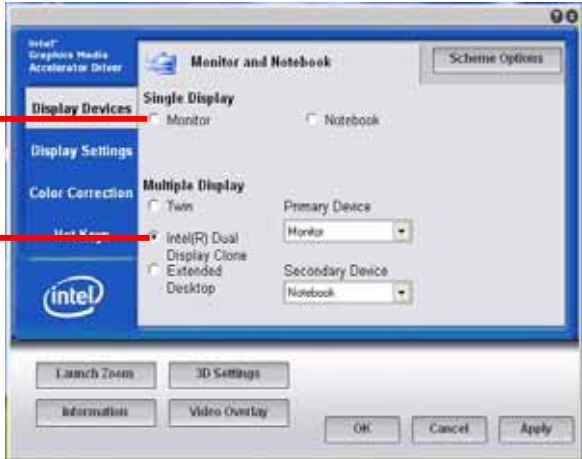

(This page is left for blank)



Appendix A <I/O Port Pin Assignment>

A.1 <Serial ATA Port>

Connector: **SATA1/2**

Type: 7-pin wafer connector

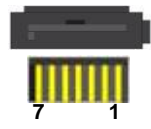

1	2	3	4	5	6	7
GND	RSATA_TXP1	RSATA_TXN1	GND	RSATA_RXN1	RSATA_RXP1	GND

A.2 <IrDA Port>

Connector: **CN_IR**

Type: 5-pin header for SIR Port

Pin	Description
1	VCC
2	N/C
3	RX
4	Ground
5	TX



JCSEL1 must jump to "SIR"

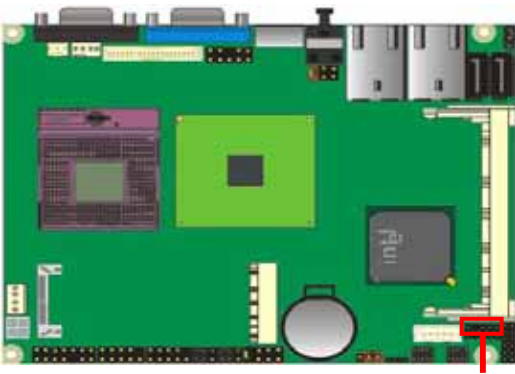

CN_IR

A.3 <Serial Port 1>

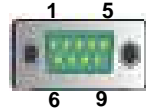

Connector: **COM1**

Type: 9-pin D-sub male connector

Pin	Description	Pin	Description
1	DCD	6	DSR
2	RX	7	RTS
3	TX	8	CTS
4	DTR	9	RI
5	Ground		

A.4 <Serial Port 2>









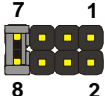

Connector: **CN_COM2**

Type: 9-pin header connector (pitch = 2.54x1.27 mm)

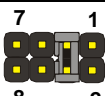
Pin	Description	Pin	Description
1	DCD/422TX-/485-	2	RX/422TX+/485+
3	TX/422RX+	4	DTR/422RX-
5	Ground	6	DSR
7	RTS	8	CTS
9	RI		

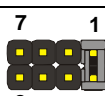
Setting RS-232 & RS-422 & RS-485:

Function	JCSEL1	JCSEL2
SIR		
RS-422		
RS-485		
RS-232		

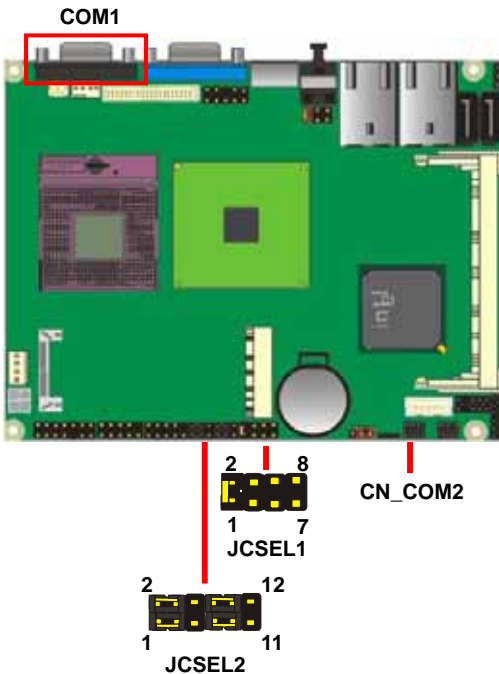

A.5 <VGA Port>

Connector: **CRT**

Type: 15-pin D-sub female connector on bracket

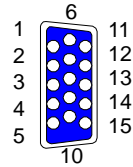

Pin	Description	Pin	Description	Pin	Description
1	RED	6	Ground	11	N/C
2	GREEN	7	Ground	12	DDCDA
3	BLUE	8	Ground	13	HSYNC
4	N/C	9	N/C	14	VSYNC
5	Ground	10	Ground	15	DDCCLK

A.6 <LAN Port>

Connector: **RJ45_1/2**

Type: RJ45 connector with LED on bracket

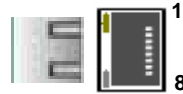

Pin	1	2	3	4	5	6	7	8
Description	MI0+	MI0-	MI1+	MI2+	MI2-	MI1-	MI3+	MI3-

A.7 <USB Interface>

Connector: **CN_USB1/2**

Type: 10-pin (5 x 2) header for dual USB Ports



Pin	Description	Pin	Description
1	VCC	2	VCC
3	Data0-	4	Data1-
5	Data0+	6	Data1+
7	Ground	8	Ground
9	Ground	10	N/C

Appendix B <Flash BIOS>

B.1 <Flash Tool>

The board is based on Award BIOS and can be updated easily by the BIOS auto flash tool. You can download the tool online at the address below:

<http://www.phoenix.com/en/home/>

File name of the tool is “awdf flash.exe”, it’s the utility that can write the data into the BIOS flash chip and update the BIOS.



B.2 <Flash BIOS Procedure>

1. Please make a bootable floppy disk.
2. Get the last .bin files you want to update and copy it into the disk.
3. Copy awdf flash.exe to the disk.
4. Power on the system and flash the BIOS. (Example: C:/ awdf flash XXX.bin)
5. Restart the system.



























Any question about the BIOS re-flash please contact your distributors or visit the web-site at below:





































Appendix C <System Resources>

C1. <Direct memory access (DMA)>

-  Direct memory access (DMA)
-  4 Direct memory access controller

C2. <Input/output (IO)>

-  Input/output (IO)
-  [00000000 - 0000000F] Direct memory access controller
-  [00000000 - 00000CF7] PCI bus
-  [00000010 - 0000001F] Motherboard resources
-  [00000020 - 00000021] Programmable interrupt controller
-  [00000022 - 0000003F] Motherboard resources
-  [00000040 - 00000043] System timer
-  [00000044 - 0000005F] Motherboard resources
-  [00000060 - 00000060] Standard 101/102-Key or Microsoft Natural PS/2 Keyboard
-  [00000061 - 00000061] System speaker
-  [00000062 - 00000063] Motherboard resources
-  [00000064 - 00000064] Standard 101/102-Key or Microsoft Natural PS/2 Keyboard
-  [00000065 - 0000006F] Motherboard resources
-  [00000070 - 00000073] System CMOS/real time clock
-  [00000074 - 0000007F] Motherboard resources
-  [00000080 - 00000090] Direct memory access controller
-  [00000091 - 00000093] Motherboard resources
-  [00000094 - 0000009F] Direct memory access controller
-  [000000A0 - 000000A1] Programmable interrupt controller
-  [000000A2 - 000000BF] Motherboard resources
-  [000000C0 - 000000DF] Direct memory access controller
-  [000000E0 - 000000EF] Motherboard resources
-  [000000F0 - 000000FF] Numeric data processor
-  [00000274 - 00000277] ISAPNP Read Data Port
-  [00000279 - 00000279] ISAPNP Read Data Port
-  [000002F8 - 000002FF] Communications Port (COM2)

	[000003B0 - 000003BB]	Mobile Intel(R) 4 Series Express Chipset Family
	[000003C0 - 000003DF]	Mobile Intel(R) 4 Series Express Chipset Family
	[000003F8 - 000003FF]	Communications Port (COM1)
	[00000400 - 000004BF]	Motherboard resources
	[000004D0 - 000004D1]	Motherboard resources
	[00000500 - 0000051F]	Intel(R) ICH9 Family SMBus Controller - 2930
	[00000680 - 000006FF]	Motherboard resources
	[00000880 - 0000088F]	Motherboard resources
	[00000A79 - 00000A79]	ISAPNP Read Data Port
	[00000D00 - 0000FFFF]	PCI bus
	[00007000 - 00007FFF]	Intel(R) ICH9 Family PCI Express Root Port 3 - 2944
	[00007F00 - 00007F1F]	Intel(R) 82574L Gigabit Network Connection #2
	[00008000 - 00008FFF]	Intel(R) ICH9 Family PCI Express Root Port 2 - 2942
	[00008F00 - 00008F1F]	Intel(R) 82574L Gigabit Network Connection
	[00009000 - 00009FFF]	Intel(R) ICH9 Family PCI Express Root Port 1 - 2940
	[0000A000 - 0000AFFF]	Intel(R) ICH9 Family PCI Express Root Port 6 - 294A
	[0000B000 - 0000BFFF]	Intel(R) ICH9 Family PCI Express Root Port 5 - 2948
	[0000C000 - 0000CFFF]	Intel(R) ICH9 Family PCI Express Root Port 4 - 2946
	[0000EC00 - 0000EC0F]	Intel(R) ICH9M/M-E 2 port Serial ATA Storage Controller 2 - 292D
	[0000ED00 - 0000ED0F]	Intel(R) ICH9M/M-E 2 port Serial ATA Storage Controller 2 - 292D
	[0000EE00 - 0000EE03]	Intel(R) ICH9M/M-E 2 port Serial ATA Storage Controller 2 - 292D
	[0000EF00 - 0000EF07]	Intel(R) ICH9M/M-E 2 port Serial ATA Storage Controller 2 - 292D
	[0000F000 - 0000F003]	Intel(R) ICH9M/M-E 2 port Serial ATA Storage Controller 2 - 292D
	[0000F100 - 0000F107]	Intel(R) ICH9M/M-E 2 port Serial ATA Storage Controller 2 - 292D
	[0000F300 - 0000F30F]	Intel(R) ICH9M/M-E 2 port Serial ATA Storage Controller 1 - 2928
	[0000F400 - 0000F40F]	Intel(R) ICH9M/M-E 2 port Serial ATA Storage Controller 1 - 2928
	[0000F500 - 0000F503]	Intel(R) ICH9M/M-E 2 port Serial ATA Storage Controller 1 - 2928
	[0000F600 - 0000F607]	Intel(R) ICH9M/M-E 2 port Serial ATA Storage Controller 1 - 2928
	[0000F700 - 0000F703]	Intel(R) ICH9M/M-E 2 port Serial ATA Storage Controller 1 - 2928
	[0000F800 - 0000F807]	Intel(R) ICH9M/M-E 2 port Serial ATA Storage Controller 1 - 2928
	[0000F900 - 0000F91F]	Intel(R) ICH9 Family USB Universal Host Controller - 2936
	[0000FA00 - 0000FA1F]	Intel(R) ICH9 Family USB Universal Host Controller - 2935
	[0000FB00 - 0000FB1F]	Intel(R) ICH9 Family USB Universal Host Controller - 2934
	[0000FC00 - 0000FC1F]	Intel(R) ICH9 Family USB Universal Host Controller - 2939
	[0000FD00 - 0000FD1F]	Intel(R) ICH9 Family USB Universal Host Controller - 2938
	[0000FE00 - 0000FE1F]	Intel(R) ICH9 Family USB Universal Host Controller - 2937
	[0000FF00 - 0000FF07]	Mobile Intel(R) 4 Series Express Chipset Family

C3. <Interrupt request (IRQ)>

Interrupt request (IRQ)

	(ISA) 0	High precision event timer
	(ISA) 1	Standard 101/102-Key or Microsoft Natural PS/2 Keyboard
	(ISA) 3	Communications Port (COM2)
	(ISA) 4	Communications Port (COM1)
	(ISA) 8	High precision event timer
	(ISA) 9	Microsoft ACPI-Compliant System
	(ISA) 12	PS/2 Compatible Mouse
	(ISA) 13	Numeric data processor
	(PCI) 11	Intel(R) ICH9 Family SMBus Controller - 2930
	(PCI) 16	Intel(R) ICH9 Family PCI Express Root Port 1 - 2940
	(PCI) 16	Intel(R) ICH9 Family PCI Express Root Port 5 - 2948
	(PCI) 16	Intel(R) ICH9 Family USB Universal Host Controller - 2937
	(PCI) 16	Mobile Intel(R) 4 Series Express Chipset Family
	(PCI) 17	Intel(R) 82574L Gigabit Network Connection
	(PCI) 17	Intel(R) ICH9 Family PCI Express Root Port 2 - 2942
	(PCI) 17	Intel(R) ICH9 Family PCI Express Root Port 6 - 294A
	(PCI) 18	Intel(R) 82574L Gigabit Network Connection #2
	(PCI) 18	Intel(R) ICH9 Family PCI Express Root Port 3 - 2944
	(PCI) 18	Intel(R) ICH9 Family USB Universal Host Controller - 2936
	(PCI) 18	Intel(R) ICH9 Family USB2 Enhanced Host Controller - 293C
	(PCI) 19	Intel(R) ICH9 Family PCI Express Root Port 4 - 2946
	(PCI) 19	Intel(R) ICH9 Family USB Universal Host Controller - 2939
	(PCI) 19	Intel(R) ICH9 Family USB Universal Host Controller - 2935
	(PCI) 19	Intel(R) ICH9M/M-E 2 port Serial ATA Storage Controller 1 - 2928
	(PCI) 19	Intel(R) ICH9M/M-E 2 port Serial ATA Storage Controller 2 - 292D
	(PCI) 21	Intel(R) ICH9 Family USB Universal Host Controller - 2938
	(PCI) 22	Microsoft UAA Bus Driver for High Definition Audio
	(PCI) 23	Intel(R) ICH9 Family USB Universal Host Controller - 2934
	(PCI) 23	Intel(R) ICH9 Family USB2 Enhanced Host Controller - 293A

C4. <Memory>

Memory	
[00000000 - 0009FFFF]	System board
[000A0000 - 000BFFFF]	Mobile Intel(R) 4 Series Express Chipset Family
[000A0000 - 000BFFFF]	PCI bus
[000C0000 - 000DFFFF]	PCI bus
[000E0000 - 000EFFFF]	System board
[000F0000 - 000FFFFF]	System board
[00100000 - 3BC8FFFF]	System board
[3BC90000 - 3BCFFFFFFF]	System board
[3BD00000 - 3BDFFFFFFF]	System board
[3BD00000 - FEBFFFFFFF]	PCI bus
[D0000000 - DFFFFFFF]	Mobile Intel(R) 4 Series Express Chipset Family
[E0000000 - EFFFFFFF]	Motherboard resources
[FCC00000 - FFFFFFFF]	Mobile Intel(R) 4 Series Express Chipset Family
[FD000000 - FD0FFFFFFF]	Intel(R) ICH9 Family PCI Express Root Port 1 - 2940
[FD400000 - FD4FFFFFFF]	Intel(R) ICH9 Family PCI Express Root Port 6 - 294A
[FD500000 - FD5FFFFFFF]	Intel(R) ICH9 Family PCI Express Root Port 6 - 294A
[FD600000 - FD6FFFFFFF]	Intel(R) ICH9 Family PCI Express Root Port 5 - 2948
[FD700000 - FD7FFFFFFF]	Intel(R) ICH9 Family PCI Express Root Port 5 - 2948
[FD800000 - FD8FFFFFFF]	Intel(R) ICH9 Family PCI Express Root Port 4 - 2946
[FD900000 - FD9FFFFFFF]	Intel(R) ICH9 Family PCI Express Root Port 4 - 2946
[FDA00000 - FDAFFFFFFF]	Intel(R) ICH9 Family PCI Express Root Port 3 - 2944
[FDB00000 - FDBFFFFFFF]	Intel(R) ICH9 Family PCI Express Root Port 3 - 2944
[FDBC0000 - FDBDFFFF]	Intel(R) 82574L Gigabit Network Connection #2
[FDBFC000 - FDBFFFFFFF]	Intel(R) 82574L Gigabit Network Connection #2
[FDC00000 - FDCFFFFFFF]	Intel(R) ICH9 Family PCI Express Root Port 2 - 2942
[FDD00000 - FDDFFFFFFF]	Intel(R) ICH9 Family PCI Express Root Port 2 - 2942
[FDDC0000 - FDDDFFFF]	Intel(R) 82574L Gigabit Network Connection
[FDDFC000 - FDDFFFFFFF]	Intel(R) 82574L Gigabit Network Connection

Appendix D <Programming GPIO's>

The GPIO's can be programmed with the MSDOS debug program using simple IN/OUT commands. The following lines show an example how to do this.

GPIO0...GPIO7 bit0...bit7

```
-o 2E 87           ;Enter configuration
-o 2E 87
-o 2E 07
-o 2F 09           ;Enable GPIO's function
-o 2E 30
-o 2F 02           ;Enable GPIO's configuration
-o 2E F0
-o 2F xx           ;Set GPIO as input/output; set '1' for
                   input,'0'for output
-o 2E F1
-o 2F xx           ;If set GPIO's as output, in this register its
                   value can be set
```

Optional:

```
-o 2E F2
-o 2F xx           ;Data inversion register; '1' inverts the
                   current values of the bits, '0' leaves them
                   as they are
-o 2E 30
-o 2F 01           ; Active GPIO's
```

For further information, please refer to Winbond W83627DHG datasheet.

Appendix E <Programming Watchdog Timer>

The watchdog timer makes the system auto-reset while it stops to work for a period.

The integrated watchdog timer can be setup as system reset mode by program.

Time-out Value Range

- 1 to 255

- Second or Minute

Program Sample

Watchdog timer setup as system reset with 5 second of timeout

2E, 87	
2E, 87	
2E, 07	
2F, 08	Logical Device 8
2E, 30	
2F, 01	Activate
2E, F5	
2F, 00	Set as Second*
2E, F6	
2F, 05	Set as 5

* Minute: bit 3 = 1; Second: bit 3 = 0

You can select Timer setting in the BIOS, after setting the time options, the system will reset according to the period of your selection.

